

UHF BAND LOW NOISE AMPLIFIER GaAs MMIC

■GENERAL DESCRIPTION

NJG1131HA8 is a low noise amplifier GaAs MMIC designed for mobile digital TV application (470~770 MHz).

This IC features good gain flatness, and low gain characteristic in out-of-band. This IC achieves low current consumption, low noise figure and low distortion. Also, this IC is integrated the ESD protection circuit.

An ultra-small and ultra-thin package of USB6-A8 is adopted.

■PACKAGE OUTLINE

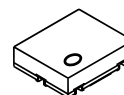

NJG1131HA8

■FEATURES

- | | |
|------------------------------------|---|
| ● Wide operating frequency range | 470~770MHz |
| ● Low voltage operation | +2.7V typ. |
| ● Low current consumption | 3.4mA typ. |
| ● Gain | 10.0dB typ. |
| ● Low noise figure | 1.4dB typ. |
| ● High P-1dB(IN) | -5.0dBm typ. |
| ● High Input IP3 | +5.0dBm typ. |
| ● Ultra-small & ultra-thin package | USB6-A8 (Package size: 1mm x 1.2mm x 0.38mm typ.) |

■PIN CONFIGURATION

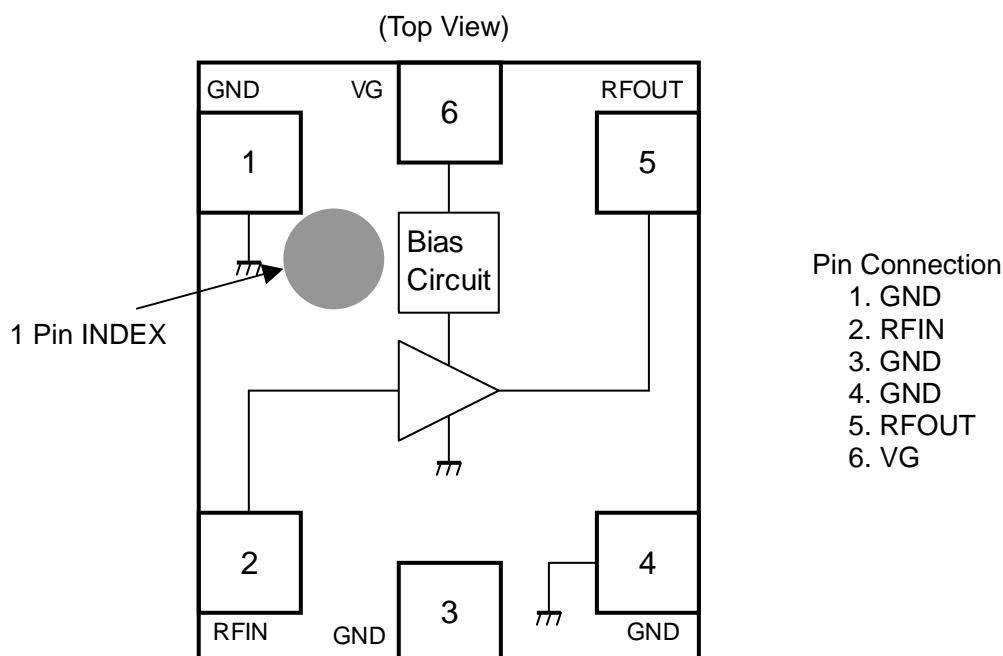

Note: Specifications and description listed in this catalog are subject to change without notice.

NJG1131HA8

■ ABSOLUTE MAXIMUM RATINGS

$T_a=+25^{\circ}\text{C}$, $Z_s=Z_l=50\ \text{ohm}$

PARAMETER	SYMBOL	CONDITIONS	RATINGS	UNITS
Drain Voltage	V_{DD}	VDD terminal	5	V
Input power	P_{IN}	$V_{DD}=2.7\text{V}$	+15	dBm
Power dissipation	P_D	On PCB board, $T_{jmax}=150^{\circ}\text{C}$	150	mW
Operating temperature	T_{opr}		-40~+85	$^{\circ}\text{C}$
Storage temperature	T_{stg}		-55~+150	$^{\circ}\text{C}$

■ ELECTRICAL CHARACTERISTICS 1 (DC)

General conditions: $V_{DD}=2.7\text{V}$, $T_a=+25^{\circ}\text{C}$, $Z_s=Z_l=50\ \text{ohm}$, with application circuit.

PARAMETERS	SYMBOL	CONDITIONS	MIN	TYP	MAX	UNITS
Operating voltage	V_{DD}		2.3	2.7	3.6	V
Operating Current	I_{DD}	RF OFF	-	3.4	5.0	mA

■ ELECTRICAL CHARACTERISTICS 2 (RF)

General conditions: $V_{DD}=2.7\text{V}$, $f_{RF}=470\sim 770\text{MHz}$, $T_a=+25^{\circ}\text{C}$, $Z_s=Z_l=50\ \text{ohm}$, with application circuit.

PARAMETERS	SYMBOL	CONDITIONS	MIN	TYP	MAX	UNITS
Operating Frequency	f_{RF}		470	620	770	MHz
Small signal gain	Gain		8.0	10.0	12.0	dB
Gain flatness	G_{flat}		-	1.1	1.4	dB
Noise figure	NF	Exclude PCB & connector losses (0.05dB)	-	1.4	1.8	dB
Input power at 1dB gain compression point	$P_{-1dB(IN)}$		-8.0	-5.0	-	dBm
Input 3rd order intercept point	IIP3	$f_1=f_{RF}$, $f_2=f_{RF}+100\text{kHz}$, $P_{in}=-28\text{dBm}$	+2.0	+5.0	-	dBm
RF IN VSWR	VSWR _i		-	2.6	3.0	
RF OUT VSWR	VSWR _o		-	2.9	3.3	

■ TERMINAL INFORMATION

No.	SYMBOL	DESCRIPTION
1	GND	Ground terminal.
2	RFIN	RF input terminal. This terminal requires the DC-blocking capacitor and the DC-feed Inductor as shown in the application circuit.
3	GND	Ground terminal.
4	GND	Ground terminal.
5	RFOUT	RF output terminal. This terminal requires the external matching circuit as shown in the application circuit.
6	VG	Power supply pin of the bias circuit. Please supply the voltage as same as the LNA voltage.

CAUTION

1) Ground terminals (1pin, 3pin and 4pin) should be connected with the ground plane close as possible.

NJG1131HA8

■ ELECTRICAL CHARACTERISTICS

(Conditions: $T_a=+25^\circ\text{C}$, $V_{DD}=2.7\text{V}$, $Z_s=Z_l=50\ \text{ohm}$, with application circuit.)

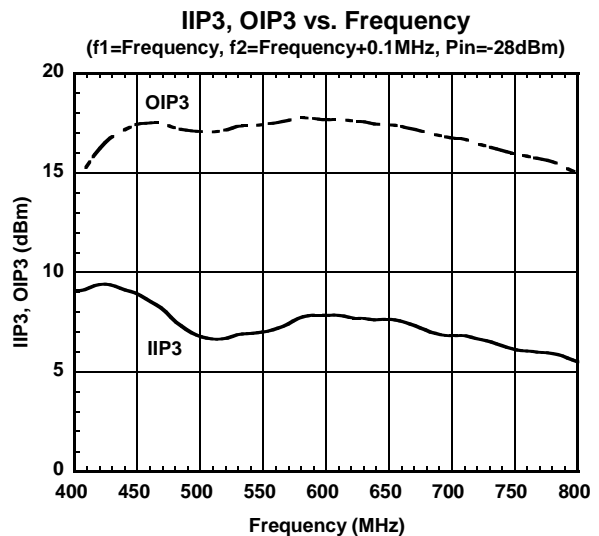
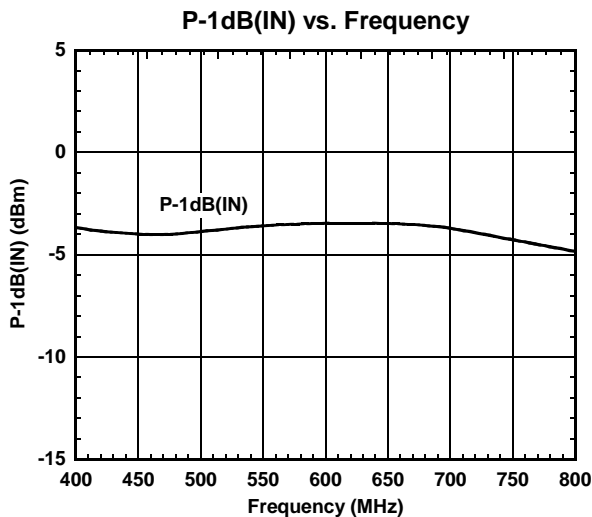
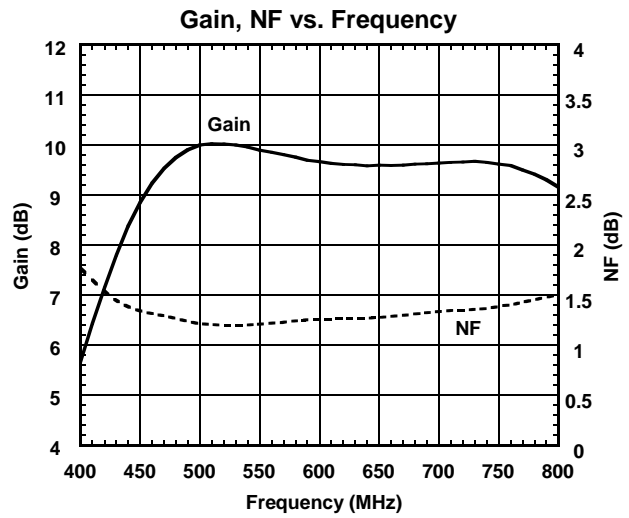
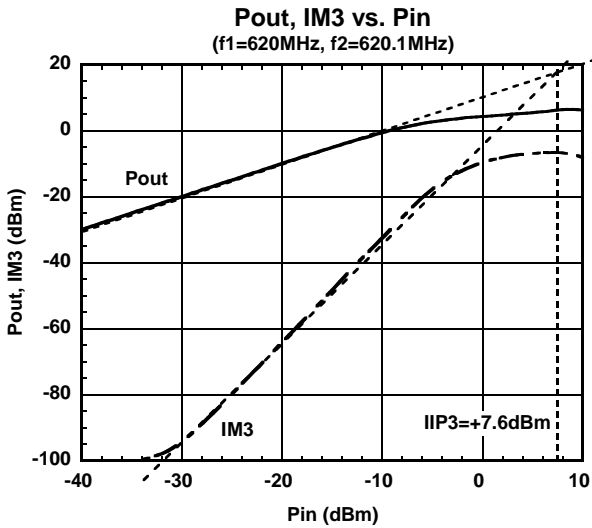
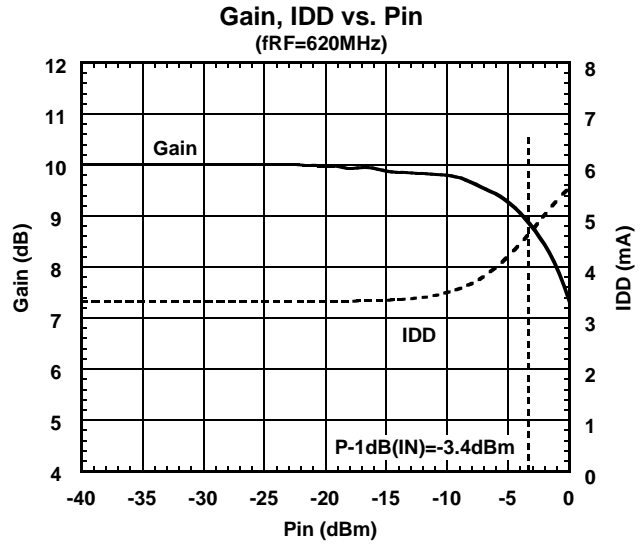
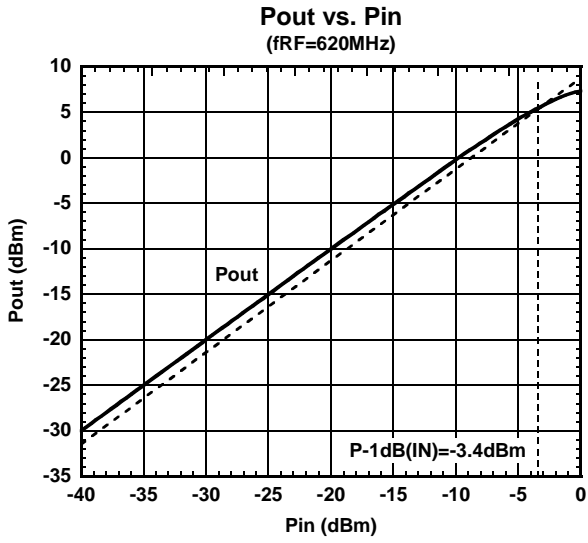

■ ELECTRICAL CHARACTERISTICS

(Conditions: $T_a=+25^\circ\text{C}$, $V_{DD}=2.7\text{V}$, $Z_s=Z_l=50\ \Omega$, with application circuit.)

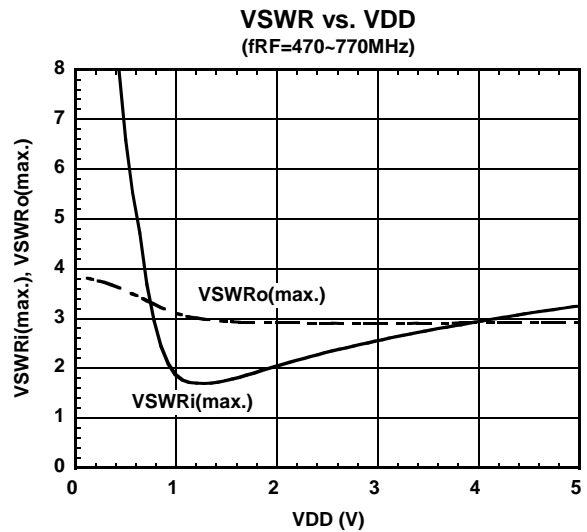
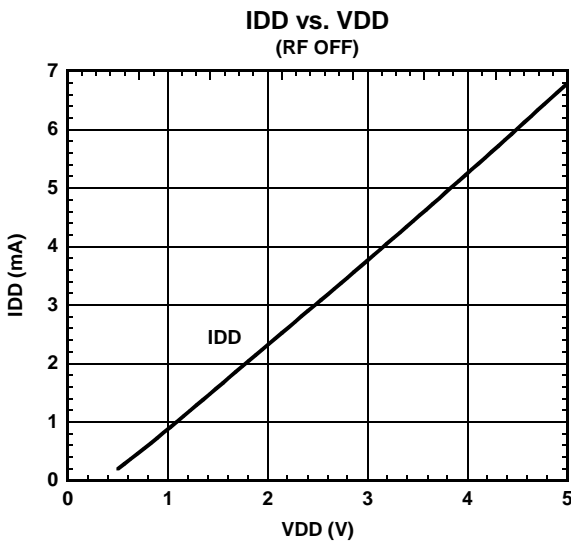
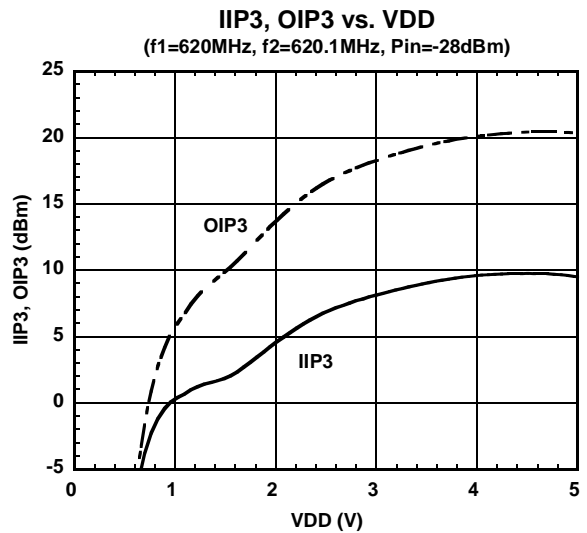
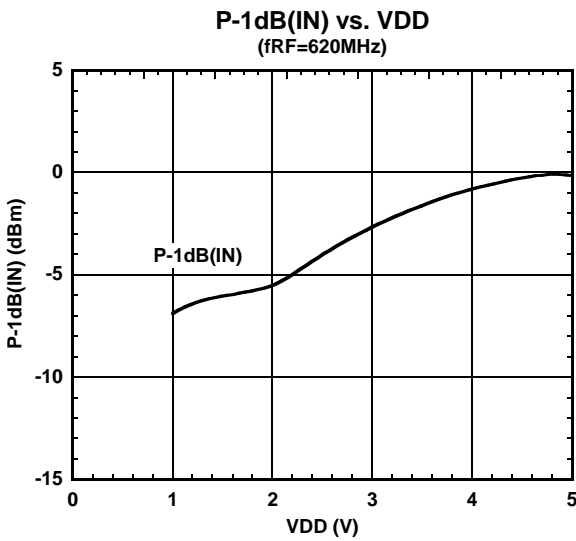
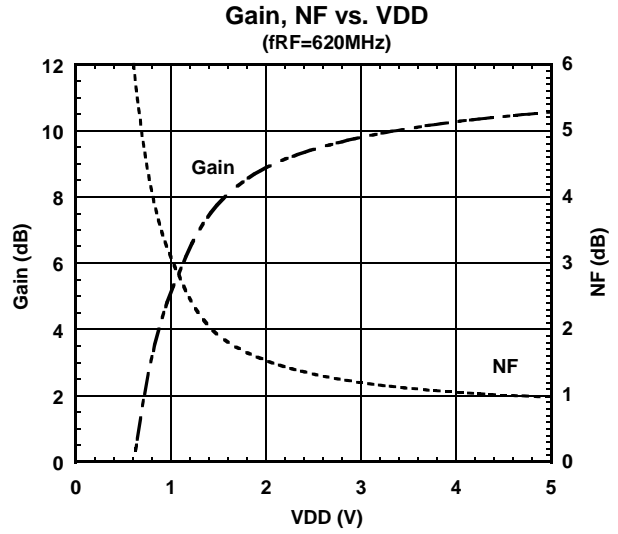
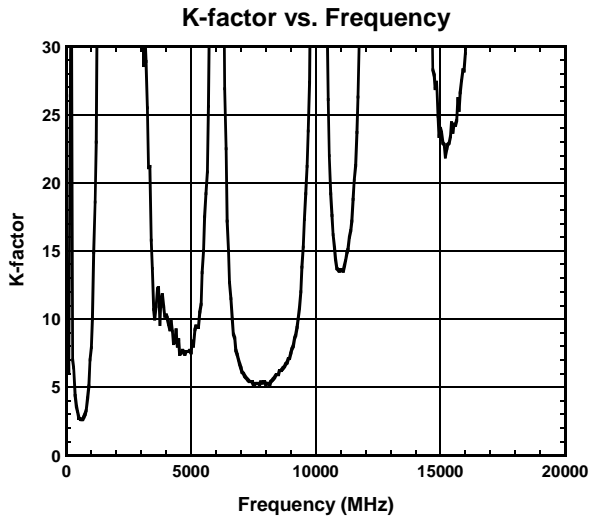

NJG1131HA8

■ ELECTRICAL CHARACTERISTICS

(Conditions: VDD=2.7V, Z_s=Z_l=50 ohm, with application circuit.)

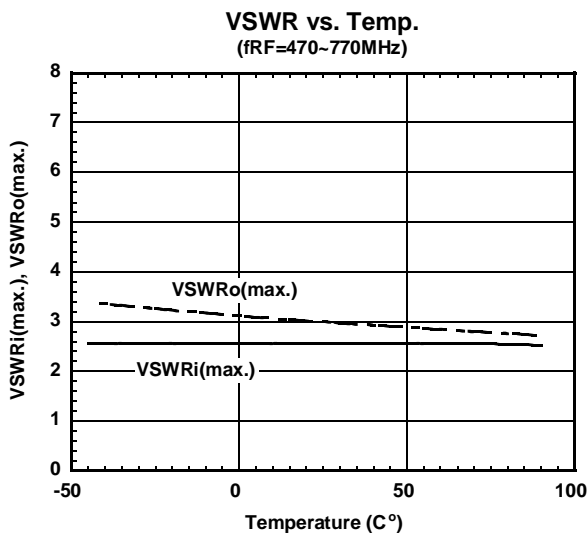
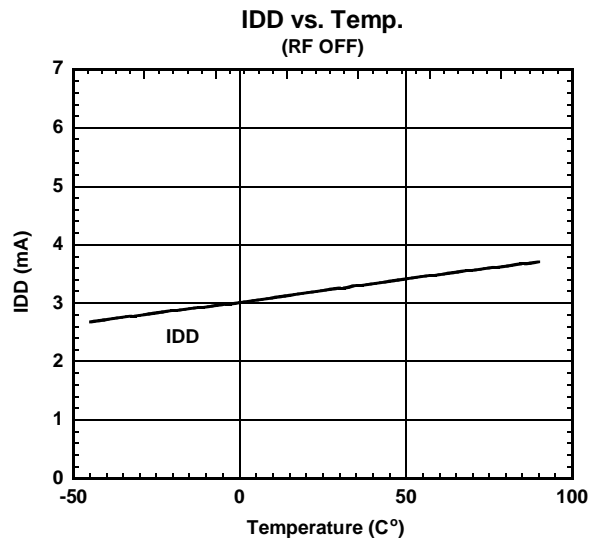
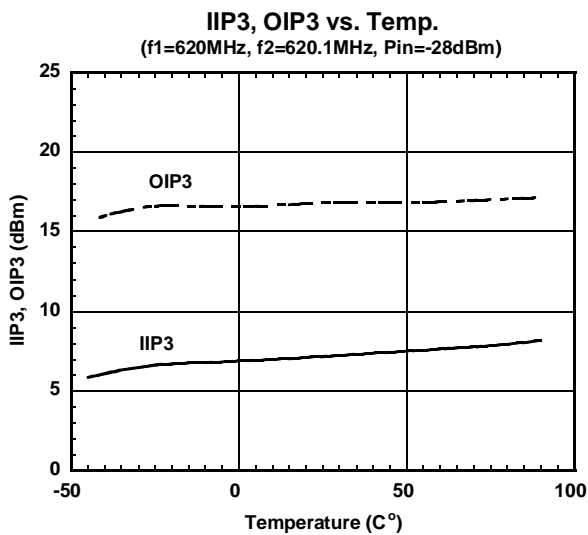
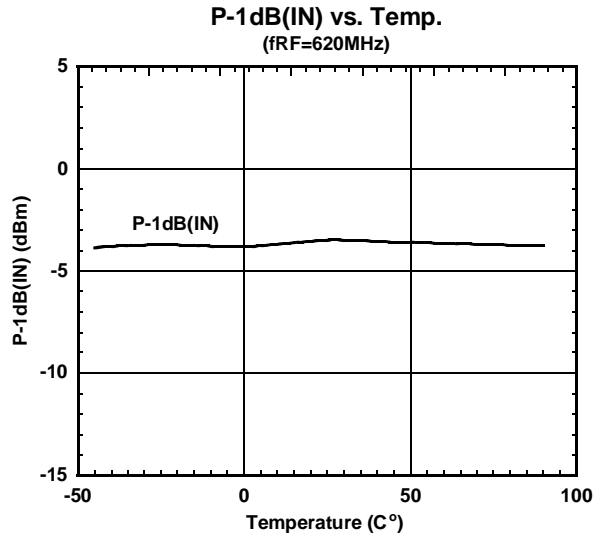
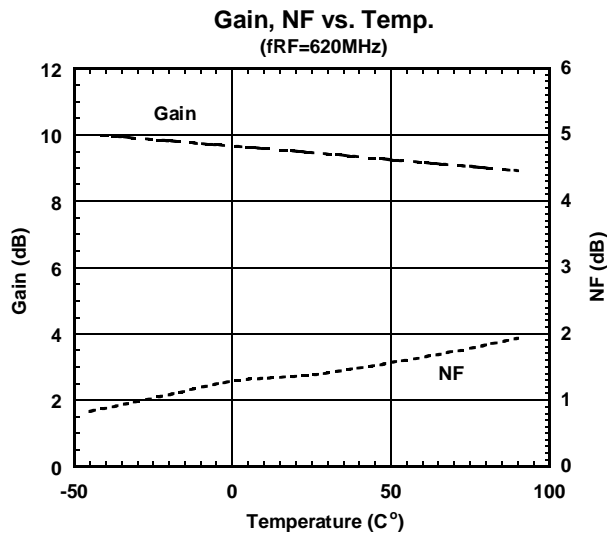

ELECTRICAL CHARACTERISTICS

(Conditions: $T_a=+25^\circ\text{C}$, $V_{DD}=2.7\text{V}$, $Z_s=Z_l=50\ \text{ohm}$, with application circuit.)

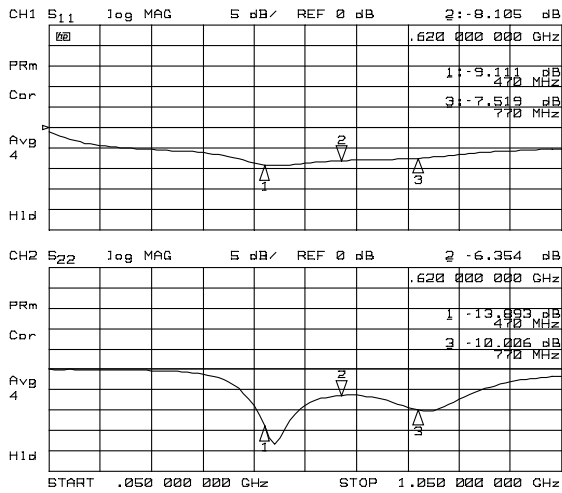

S11, S22

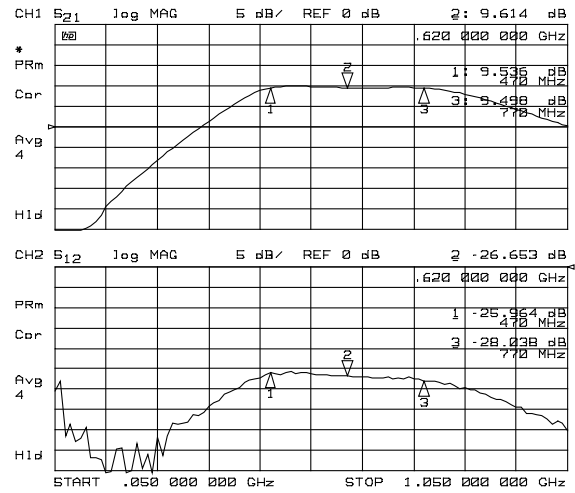

S21, S12

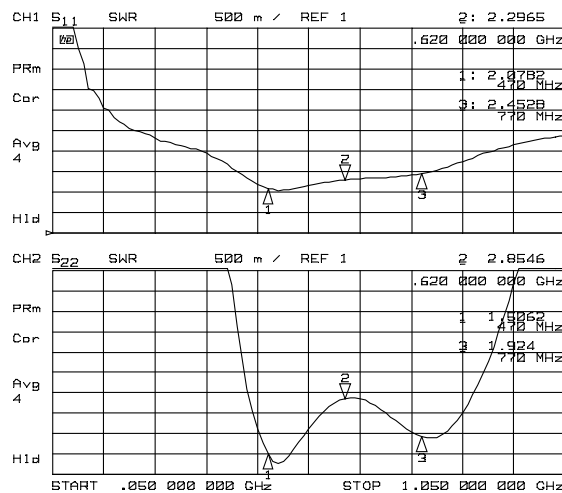

VSWR

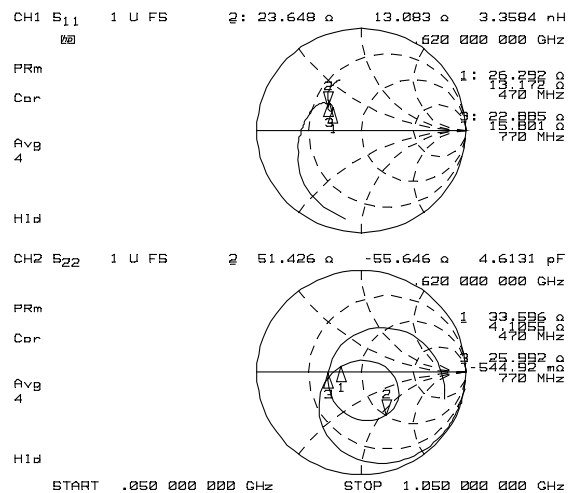

Zin, Zout

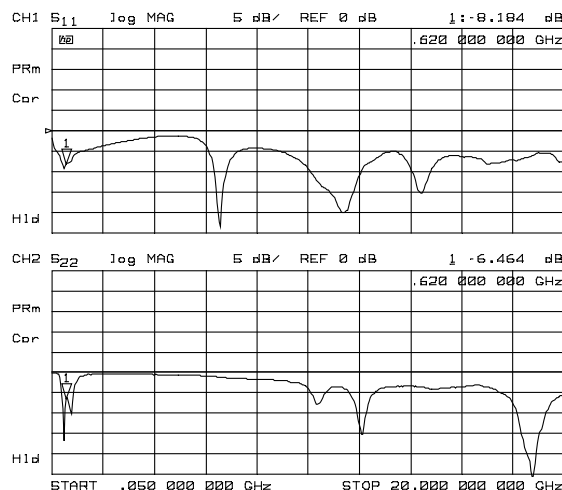

S11, S22 (~20GHz)

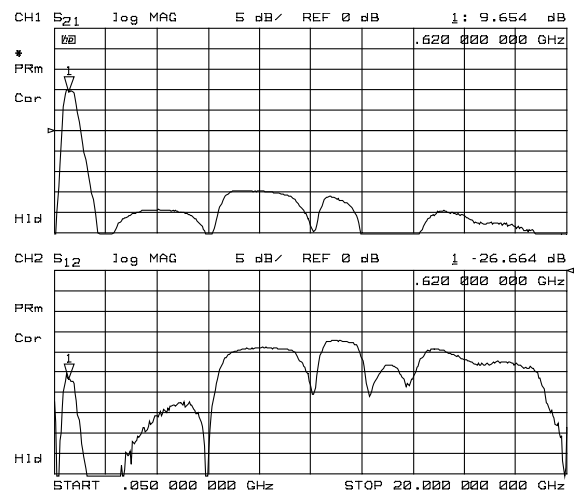

S21, S12 (~20GHz)

NJG1131HA8

TEST CIRCUIT

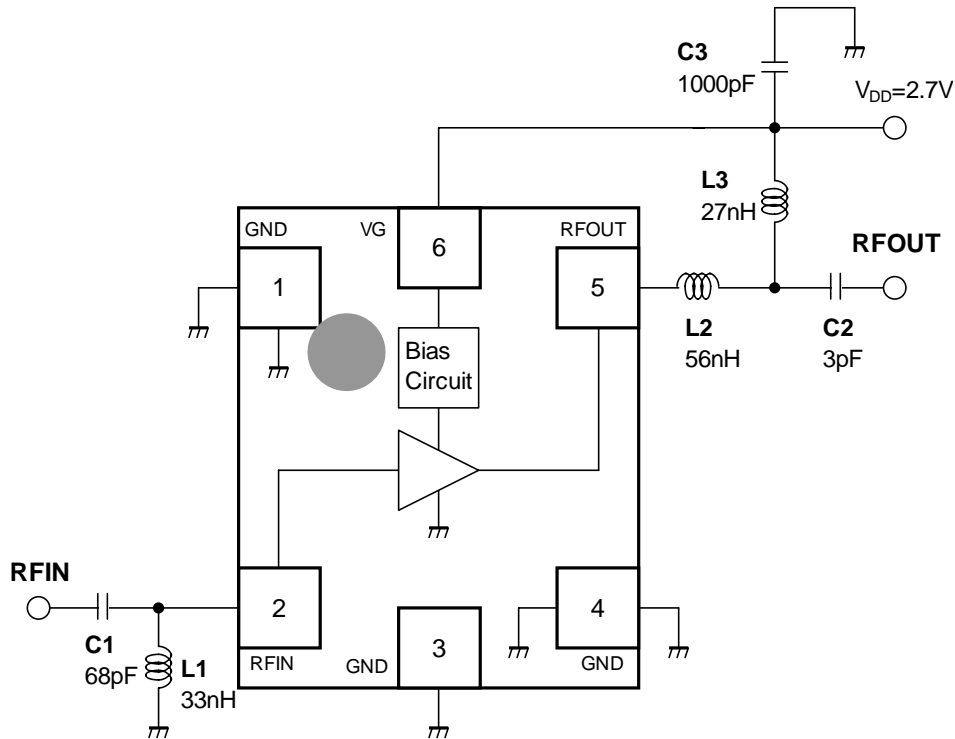

TEST PCB LAYOUT

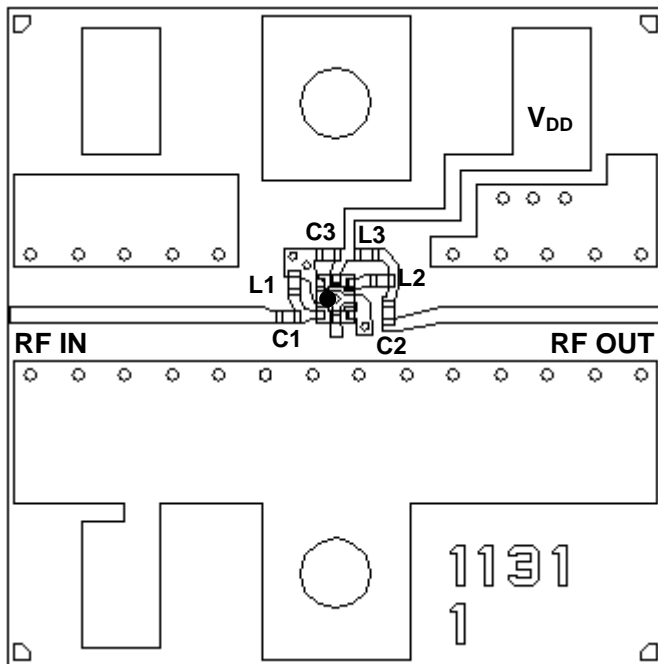

Parts List

Parts ID	Notes
L1~L3	MURATA (LQP03T series)
C1~C3	MURATA (GRM03 series)

PCB (FR-4):
 $t=0.2\text{mm}$
 MICROSTRIP LINE
 WIDTH=0.4mm ($Z_0=50\ \text{ohm}$)
 PCB SIZE=16.8mmx16.8mm

PRECAUTIONS

- [1] C1 is a DC-Blocking capacitor, and L1 is a DC-feed inductor.
- [2] L2, L3, and C2 formed the output matching circuit.
- [3] C3 is a bypass capacitor.
- [4] Ground terminals (1pin, 3pin and 4pin) should be connected with ground plane as close as possible in order to limit ground path induction.
- [5] All external parts are placed as close as possible to the IC.

MEASUREMENT BLOCK DIAGRAM

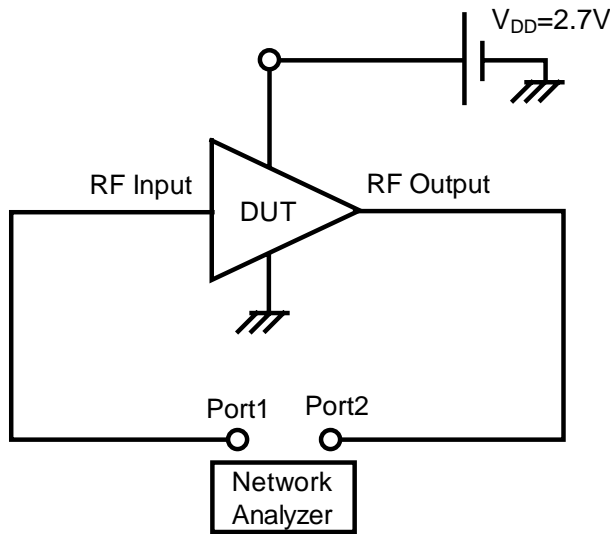

S parameter Measurement Block Diagram

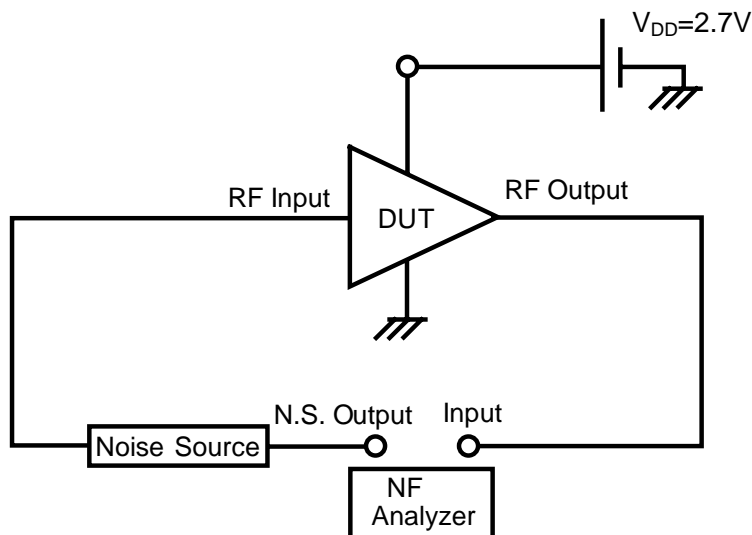

Noise Figure Measurement Block Diagram

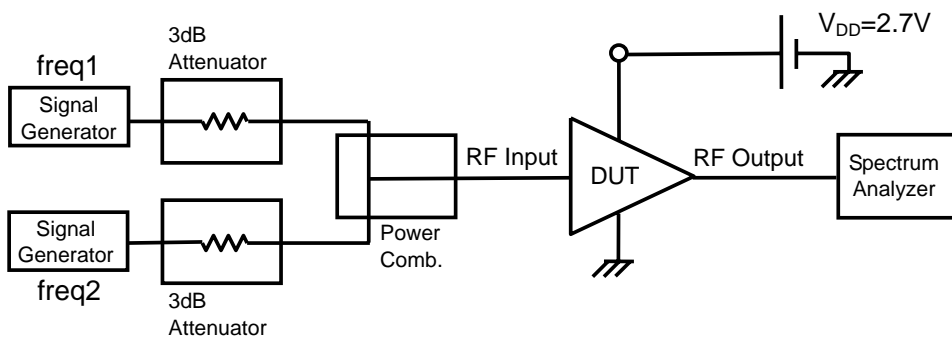

IF and IM3 Measurement Block Diagram for IIP3

NJG1131HA8

PACKAGE OUTLINE (USB6-A8)

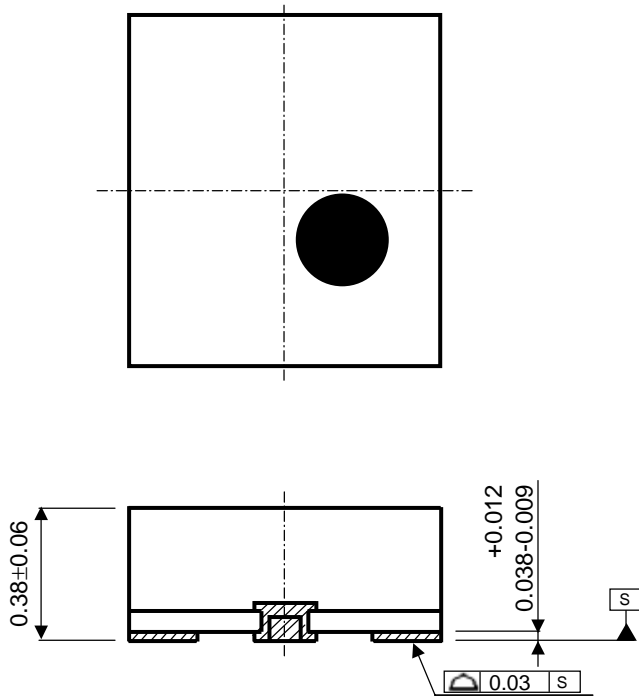

TERMINAL TREAT	:Au
Substrate	:FR5
Molding material	:Epoxy resin
UNIT	:mm
WEIGHT	:1.1mg

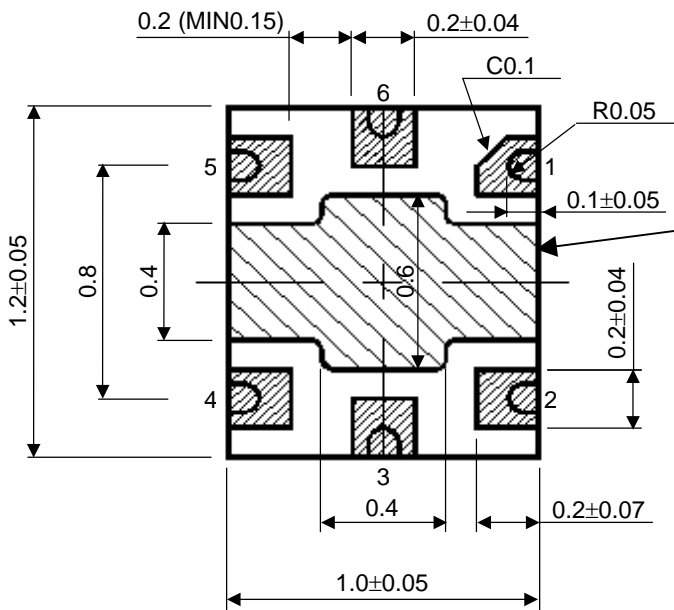
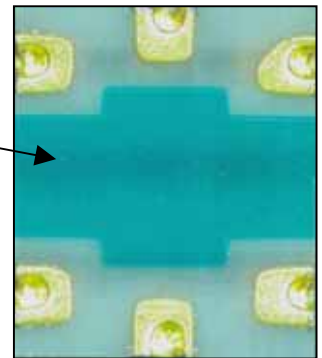

Photo resist coating



Cautions on using this product

This product contains Gallium-Arsenide (GaAs) which is a harmful material.

- Do NOT eat or put into mouth.
- Do NOT dispose in fire or break up this product.
- Do NOT chemically make gas or powder with this product.
- To waste this product, please obey the relating law of your country.

[CAUTION]

The specifications on this databook are only given for information, without any guarantee as regards either mistakes or omissions. The application circuits in this databook are described only to show representative usages of the product and not intended for the guarantee or permission of any right including the industrial rights.

This product may be damaged with electric static discharge (ESD) or spike voltage. Please handle with care to avoid these damages.



Компания «ЭлектроПласт» предлагает заключение долгосрочных отношений при поставках импортных электронных компонентов на взаимовыгодных условиях!

Наши преимущества:

- Оперативные поставки широкого спектра электронных компонентов отечественного и импортного производства напрямую от производителей и с крупнейших мировых складов;
- Поставка более 17-ти миллионов наименований электронных компонентов;
- Поставка сложных, дефицитных, либо снятых с производства позиций;
- Оперативные сроки поставки под заказ (от 5 рабочих дней);
- Экспресс доставка в любую точку России;
- Техническая поддержка проекта, помощь в подборе аналогов, поставка прототипов;
- Система менеджмента качества сертифицирована по Международному стандарту ISO 9001;
- Лицензия ФСБ на осуществление работ с использованием сведений, составляющих государственную тайну;
- Поставка специализированных компонентов (Xilinx, Altera, Analog Devices, Intersil, Interpoint, Microsemi, Aeroflex, Peregrine, Syfer, Eurofarad, Texas Instrument, Miteq, Cobham, E2V, MA-COM, Hittite, Mini-Circuits, General Dynamics и др.);

Помимо этого, одним из направлений компании «ЭлектроПласт» является направление «Источники питания». Мы предлагаем Вам помощь Конструкторского отдела:

- Подбор оптимального решения, техническое обоснование при выборе компонента;
- Подбор аналогов;
- Консультации по применению компонента;
- Поставка образцов и прототипов;
- Техническая поддержка проекта;
- Защита от снятия компонента с производства.



Как с нами связаться

Телефон: 8 (812) 309 58 32 (многоканальный)

Факс: 8 (812) 320-02-42

Электронная почта: org@eplast1.ru

Адрес: 198099, г. Санкт-Петербург, ул. Калинина, дом 2, корпус 4, литера А.