



**5.5GHz 1:4 FANOUT BUFFER/
TRANSLATOR w/400mV LVPECL
OUTPUTS AND INTERNAL INPUT TERMINATION**

**Precision Edge®
SY58022U**

FEATURES

- Precision 1:4, 400mV LVPECL fanout buffer
- Guaranteed AC performance over temperature and voltage:
 - >5.5GHz f_{MAX} clock
 - <80ps t_r/t_f times
 - <250ps ($V_{IN} \geq 300mV$) t_{pd}
 - <15ps max. skew
- Low jitter performance:
 - <10ps_{pp} total jitter (clock)
 - <1ps_{RMS} random jitter (data)
 - <10ps_{pp} deterministic jitter (data)
- Accepts an input signal as low as 100mV
- Unique input termination and V_T pin accepts DC- and AC-coupled differential inputs: LVPECL, LVDS and CML
- 400mV LVPECL compatible outputs
- Power supply 2.5V ±5% and 3.3V ±10%
- -40°C to +85°C temperature range
- Available in 16-pin (3mm × 3mm) MLF® package

APPLICATIONS

- All SONET and All GigE clock distribution
- Fibre Channel clock and data distribution
- Backplane distribution
- Data distribution: OC-48, OC-48+FEC, XAUI
- High-end, low-skew, multiprocessor synchronous clock distribution

FUNCTIONAL BLOCK DIAGRAM

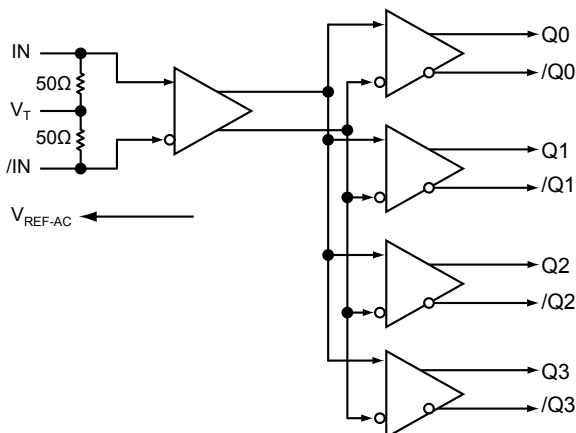

TYPICAL PERFORMANCE

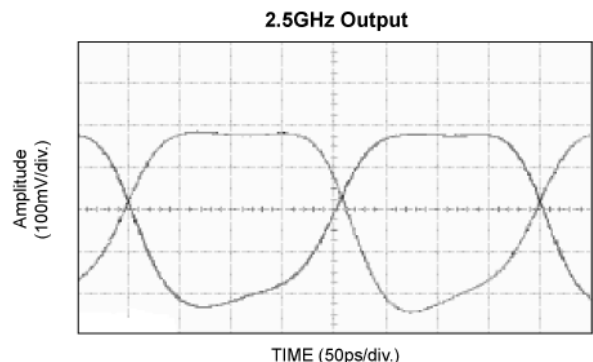

Precision Edge®

DESCRIPTION

The SY58022U is a 2.5V/3.3V precision, high-speed, fully differential 1:4 LVPECL fanout buffer. Optimized to provide four identical output copies with less than 15ps of skew and less than 10ps_{pp} total jitter, the SY58022U can process clock signals as fast as 5.5GHz.

The differential input includes Micrel's unique, 3-pin input termination architecture interfaces to differential LVPECL, CML, and LVDS signals (AC- or DC-coupled) as small as 100mV without any level-shifting or termination resistor networks in the signal path. For AC-coupled input interface applications, an on-board output reference voltage (V_{REF-AC}) is provided to bias the V_T pin. The outputs are 400mV LVPECL compatible, with extremely fast rise/fall times guaranteed to be less than 80ps.

The SY58022U operates from a 2.5V ±5% supply or 3.3V ±10% supply and is guaranteed over the full industrial temperature range (-40°C to +85°C). For applications that require greater output swing or CML compatible outputs, consider the SY58021U 1:4 fanout buffer with LVPECL outputs, or the SY58020U 1:4 fanout buffer with 400mV CML outputs. The SY58022U is part of Micrel's high-speed, Precision Edge® product line. All data sheets and support documentation can be found on Micrel's web site at: www.micrel.com.

PACKAGE/ORDERING INFORMATION

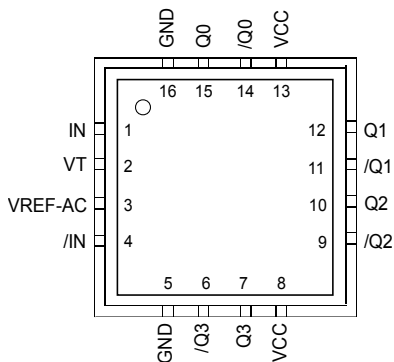

Ordering Information⁽¹⁾

Part Number	Package Type	Operating Range	Package Marking	Lead Finish
SY58022UMI	MLF-16	Industrial	022U	Sn-Pb
SY58022UMITR ⁽²⁾	MLF-16	Industrial	022U	Sn-Pb
SY58022UMG	MLF-16	Industrial	022U with Pb-Free bar-line indicator	Pb-Free NiPdAu
SY58022UMGTR ⁽²⁾	MLF-16	Industrial	022U with Pb-Free bar-line indicator	Pb-Free NiPdAu

Notes:

1. Contact factory for die availability. Die are guaranteed at $T_A = 25^\circ\text{C}$, DC electricals only.
2. Tape and Reel.

16-Pin MLF® (MLF-16)

PIN DESCRIPTION

Pin Number	Pin Name	Pin Function
1, 4	IN, /IN	Differential Input: This input pair receives the signal to be buffered. Each pin is internally terminated with 50Ω to the V_T pin. Note that this input will default to an indeterminate state if left open. See “Input Interface Applications” section.
2	VT	Input Termination Center-Tap: Each input terminates to this pin. The V_T pin provides a center-tap for each input (IN, /IN) to the termination network for maximum interface flexibility. See “Input Interface Applications” section.
3	VREF-AC	Reference Output Voltage: This output biases to $V_{CC} - 1.2\text{V}$. It is used when AC-coupling to differential inputs. Connect V_{REF-AC} directly to the V_T pin. Bypass with 0.01μF low ESR capacitor to V_{CC} . See “Input Interface Applications” section.
8, 13	VCC	Positive Power Supply: Bypass with 0.1μF//0.01μF low ESR capacitors as close to the pins as possible. A 0.01μF capacitor should be as close to the V_{CC} pin as possible.
5, 16	GND, Exposed Pad	Ground. Exposed pad must be connected to a ground plane that is the same potential as the ground pin.
14, 15 11, 12 9, 10 6, 7	/Q0, Q0, /Q1, Q1, /Q2, Q2, /Q3, Q3,	LVPECL Differential Output Pairs: Differential buffered output copy of the input signal. The output swing is typically 400mV. Proper termination is 50Ω to $V_{CC} - 2\text{V}$ at the receiving end. Unused output pairs may be left floating with no impact on jitter or skew. See “LVPECL Output Termination” section.

Absolute Maximum Ratings⁽¹⁾

Power Supply Voltage (V_{CC}) -0.5V to +4.0V
 Input Voltage (V_{IN})..... -0.5V to V_{CC}
 Output Current (I_{OUT})
 Continuous 50mA
 Surge 100mA
 V_T Current
 Source or sink current on V_T pin ± 100 mA
 Input Current
 Source or sink current on (IN, /IN)..... ± 50 mA
 V_{REF} Current
 Source or sink current on V_{REF-AC} , Note 4..... ± 1.5 mA
 Soldering, (20 sec.) 260°C
 Storage Temperature Range (T_{STORE}) -65 to +150°C

Operating Ratings⁽²⁾

Power Supply Voltage (V_{CC}) +2.375V to +3.60V
 Operating Temperature Range (T_A) -40°C to +85°C
 Package Thermal Resistance
 MLF® (θ_{JA})
 Still-Air 60°C/W
 500lpm 54°C/W
 MLF® (θ_{JB})
 (Junction-to-Board Resistance), Note 3 33°C/W

DC ELECTRICAL CHARACTERISTICS^(Note 5)

$T_A = -40^\circ\text{C}$ to $+85^\circ\text{C}$

Symbol	Parameter	Condition	Min	Typ	Max	Units
V_{CC}	Power Supply Voltage	$V_{CC} = 2.5\text{V}$	2.375	2.5	2.625	V
		$V_{CC} = 3.3\text{V}$	3.0	3.3	3.60	V
I_{CC}	Power Supply Current	No load, $V_{CC} = \text{max}$		125	160	mA
V_{IH}	Input HIGH Voltage	IN, /IN, Note 6	$V_{CC}-1.6$		V_{CC}	V
V_{IL}	Input LOW Voltage	IN, /IN	0		$V_{IH}-0.1$	V
V_{IN}	Input Voltage Swing	IN, /IN; See Figure 1a	0.1		3.6	V
V_{DIFF_IN}	Differential Input Voltage	IN, /IN; See Figure 1b	0.2		3.4	V
R_{IN}	IN-to- V_T Resistance		40	50	60	Ω
V_{REF-AC}	Output Reference Voltage		$V_{CC}-1.3$	$V_{CC}-1.2$	$V_{CC}-1.1$	V
V_{TIN}	IN-to- V_T Voltage				1.28	V

LVPECL DC ELECTRICAL CHARACTERISTICS^(Note 5)

$V_{CC} = 3.3\text{V} \pm 10\%$ or $V_{CC} = 2.5 \pm 5\%$; $R_L = 50\Omega$ to $V_{CC}-2\text{V}$; $T_A = -40^\circ\text{C}$ to 85°C , unless otherwise stated.

Symbol	Parameter	Condition	Min	Typ	Max	Units
V_{OH}	Output HIGH Voltage		$V_{CC}-1.145$	$V_{CC}-1.020$	$V_{CC}-0.895$	V
V_{OL}	Output LOW Voltage		$V_{CC}-1.545$	$V_{CC}-1.420$	$V_{CC}-1.295$	V
V_{OUT}	Output Differential Swing	see Figure 1a	150	400	650	mV
V_{DIFF_OUT}	Differential Output Swing	see Figure 1b	300	800	1300	mV

Notes:

1. Permanent device damage may occur if ABSOLUTE MAXIMUM RATINGS are exceeded. This is a stress rating only and functional operation is not implied at conditions other than those detailed in the operational sections of this data sheet. Exposure to ABSOLUTE MAXIMUM RATINGS conditions for extended periods may affect device reliability.
2. The data sheet limits are not guaranteed if the device is operated beyond the operating ratings.
3. Thermal performance assumes exposed pad is soldered (or equivalent) to the device's most negative potential on the PCB.
4. Due to the limited drive capability, use for input of the same package only.
5. The circuit is designed to meet the DC specifications shown in the above table after thermal equilibrium has been established.
6. V_{IH} (min.) not lower than 1.2V.

AC ELECTRICAL CHARACTERISTICS

$V_{CC} = 2.5V \pm 5\%$ or $3.3V \pm 10\%$; $R_L = 50\Omega$ to $V_{CC} - 2V$; $T_A = -40^\circ C$ to $+85^\circ C$, unless otherwise stated.

Symbol	Parameter	Condition	Min	Typ	Max	Units	
f_{MAX}	Maximum Operating Frequency	$V_{OUT} \geq 200mV$ Clock	5.5			GHz	
		NRZ Data		10		Gbps	
t_{pd}	Propagation Delay		130	200	280	ps	
t_{CHAN}	Channel-to-Channel Skew	Note 7		4	15	ps	
t_{SKEW}	Part-to-Part Skew	Note 8			50	ps	
t_{JITTER}	Clock Cycle-to-Cycle Jitter	Note 9			1	ps_{RMS}	
		Note 10			10	ps_{PP}	
	Data Random Jitter	Note 11	2.5Gbps – 3.2Gbps			1	ps_{RMS}
		Note 12	2.5Gbps – 3.2Gbps			10	ps_{PP}
t_r, t_f	Output Rise/Fall Time 20% to 80%	At full swing	20	50	80	ps	

Notes:

7. Skew is measured between outputs of the same bank under identical transitions.
8. Skew is defined for two parts with identical power supply voltages at the same temperature and with no skew of the edges at the respective inputs.
9. Cycle-to-cycle jitter definition: the variation of periods between adjacent cycles, $T_n - T_{n-1}$ where T is the time between rising edges of the output signal.
10. Total jitter definition: with an ideal clock input of frequency $\leq f_{MAX}$, no more than one output edge in 10^{12} output edges will deviate by more than the specified peak-to-peak jitter value.
11. Random jitter is measured with a K28.7 comma detect character pattern, measured at 2.5Gbps/3.2Gbps.
12. Deterministic jitter is measured at 2.5Gbps/3.2Gbps with both K28.5 and $2^{23}-1$ PRBS pattern.

TIMING DIAGRAM

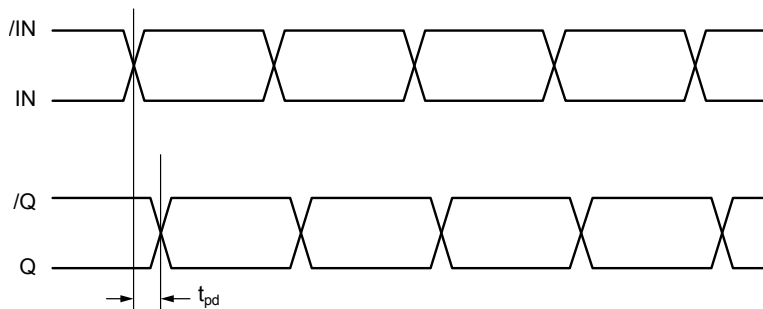

SINGLE-ENDED AND DIFFERENTIAL SWINGS

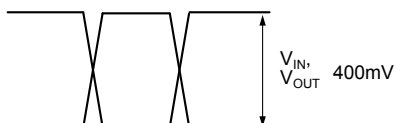

Figure 1a. Single-Ended Swing

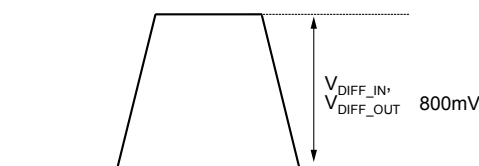
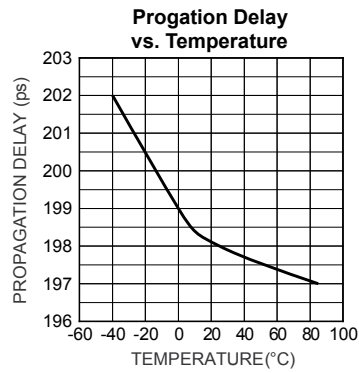
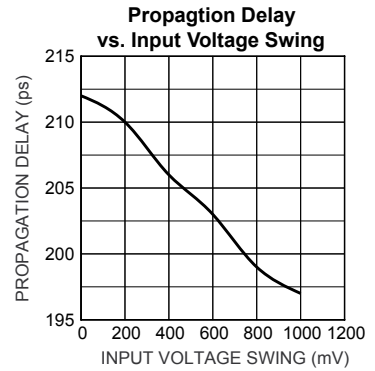
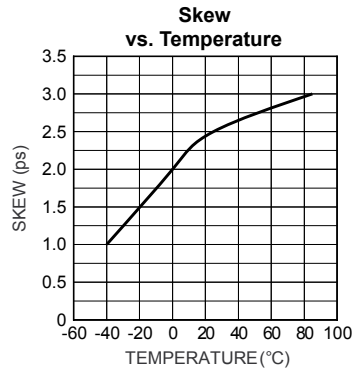
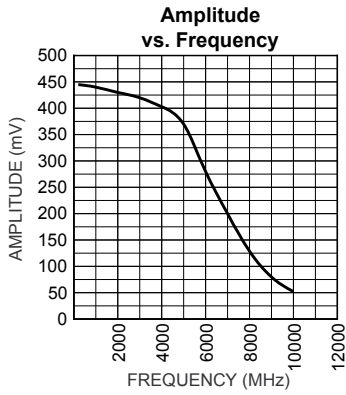

Figure 1b. Differential Swing

TYPICAL OPERATING CHARACTERISTICS

$V_{CC} = 3.3V$, $V_{EE} = 0V$, $V_{IN} = 100mV$, $T_A = 25^\circ C$, unless otherwise stated.



FUNCTIONAL CHARACTERISTICS

$V_{CC} = 3.3V$, $V_{EE} = 0V$, $V_{IN} = 100mV$, $T_A = 25^\circ C$, unless otherwise stated.

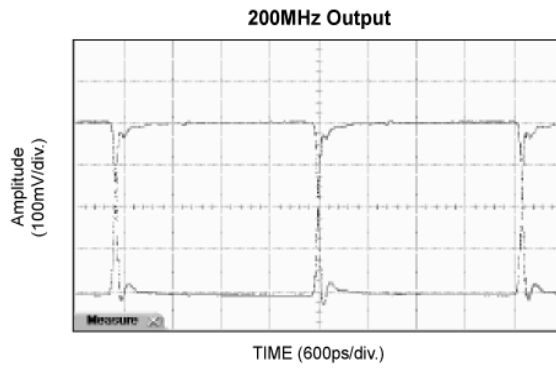
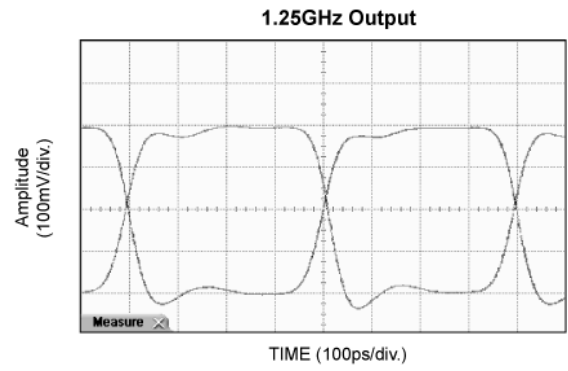
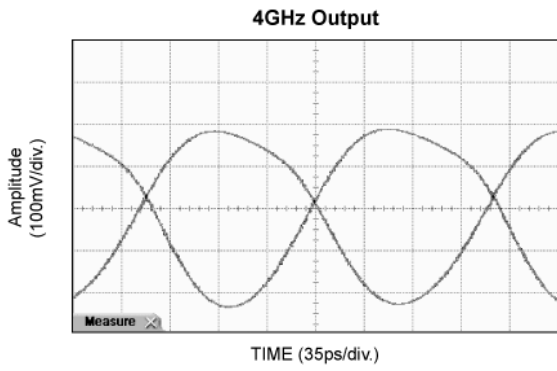

INPUT STAGE

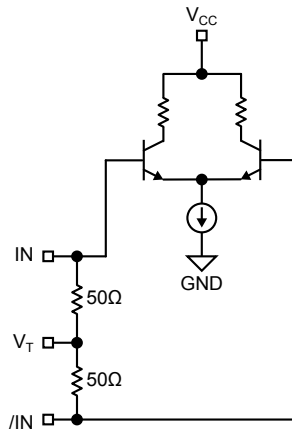

Figure 2. Simplified Differential Input Buffer

INPUT INTERFACE APPLICATIONS

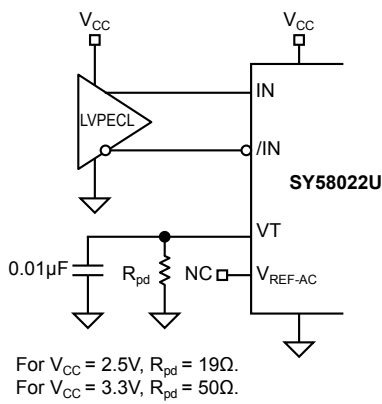

Figure 3a. DC-Coupled LVPECL Input Interface

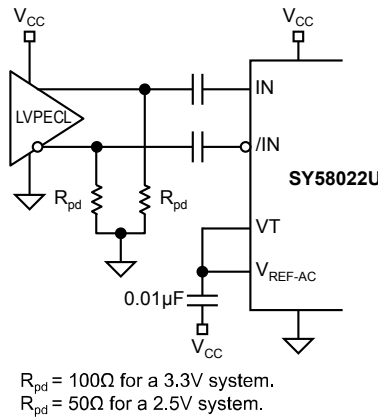

Figure 3b. AC-Coupled LVPECL Input Interface

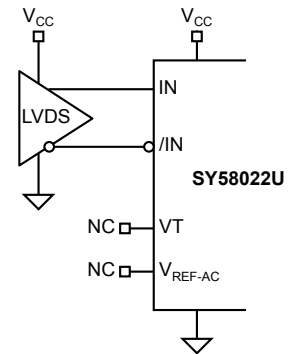

Figure 3c. LVDS Input Interface

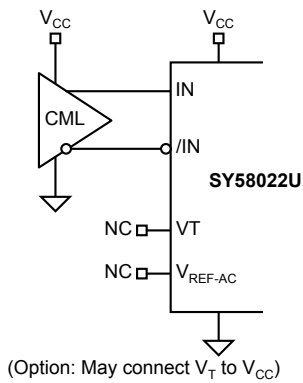

Figure 3d. AC-Coupled CML Input Interface

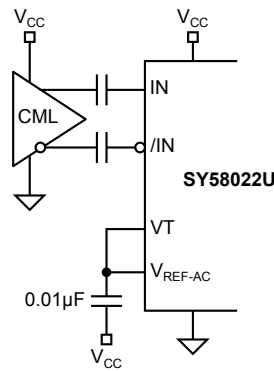

Figure 3e. CML Input Interface

OUTPUT TERMINATION RECOMMENDATIONS

LVPECL outputs have very low output impedance (open emitter), and small signal swing which results in low EMI (electro-magnetic interference). The LVPECL is ideal for driving 50Ω- and 100Ω-controlled impedance transmission lines. In addition, LVPECL is compatible for driving standard

PECL inputs since PECL inputs require only 100mV input swing. Further, there are several techniques in terminating the LVPECL outputs, as shown in Figure 4 through 6.

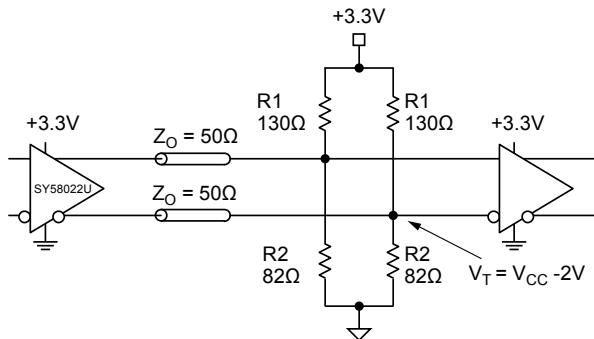

Figure 4. Parallel Termination–Thevenin Equivalent

Notes:

1. For +2.5V systems: R1 = 250Ω, R2 = 62.5Ω.
2. For +3.3V systems: R1 = 130Ω, R2 = 83Ω.

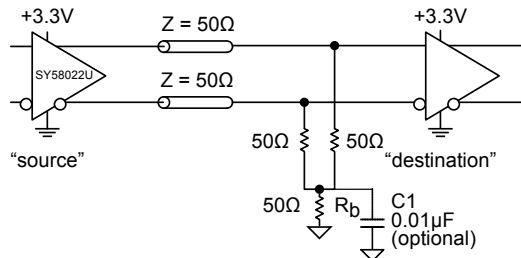

Figure 5. Three-Resistor “Y-Termination”

Notes:

1. Power-saving alternative to Thevenin termination.
2. Place termination resistors as close to destination inputs as possible.
3. R_b resistor sets the DC bias voltage, equal to V_T.
For +2.5V systems R_b = 19Ω.
For +3.3V systems R_b = 46Ω to 50Ω.
4. C1 is an optional bypass capacitor intended to compensate for any t_r/t_f mismatches.

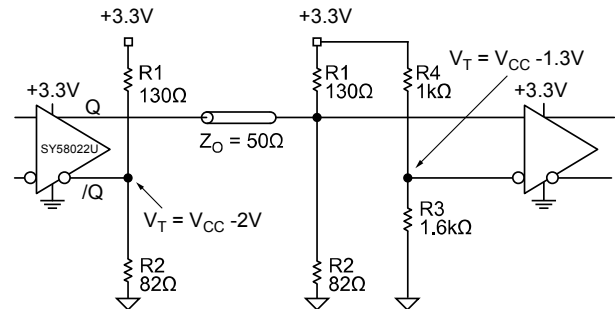

Figure 6. Terminating Unused I/O

Notes:

1. Unused output (/Q) must be terminated to balance the output.
2. For +2.5V systems: R1 = 250Ω, R2 = 62.5Ω, R3 = 1.25kΩ, R4 = 1.2kΩ.
For +3.3V systems: R1 = 130Ω, R2 = 82Ω, R3 = 1kΩ, R4 = 1.6kΩ.
3. Unused output pairs (Q and /Q) may be left floating.

RELATED MICREL PRODUCTS AND SUPPORT DOCUMENTATION

Part Number	Function	Data Sheet Link
SY58020U	6GHz, 1:4 CML Fanout Buffer/Translator Internal I/O Termination	http://www.micrel.com/product-info/products/sy58020u.shtml
SY58021U	4GHz, 1:4 LVPECL Fanout Buffer/Translator with Internal Termination	http://www.micrel.com/product-info/products/sy58021u.shtml
SY58022U	5.5GHz, 1:4 Fanout Buffer/Translator w/400mV LVPECL Outputs and Internal Input Termination	http://www.micrel.com/product-info/products/sy58022u.shtml
	16-MLF® Manufacturing Guidelines Exposed Pad Application Note	www.amkor.com/products/notes_papers/MLF_AppNote_0902.pdf
M-0317	HBW Solutions	http://www.micrel.com/product-info/as/solutions.shtml

16-PIN MicroLeadFrame® (MLF-16)

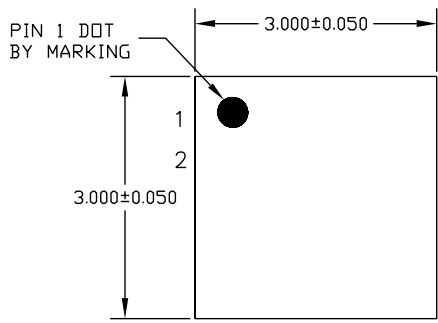

TOP VIEW

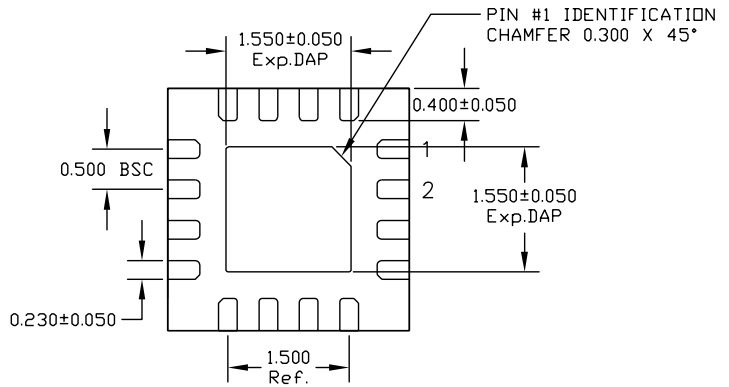

BOTTOM VIEW

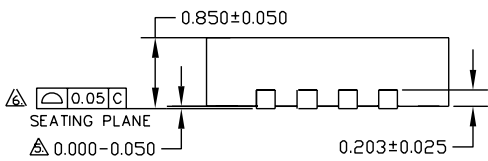

SIDE VIEW

- NOTE:
1. ALL DIMENSIONS ARE IN MILLIMETERS.
 2. MAX. PACKAGE WARPAGE IS 0.05 mm.
 3. MAXIMUM ALLOWABLE BURRS IS 0.076 mm IN ALL DIRECTIONS.
 4. PIN #1 ID ON TOP WILL BE LASER/INK MARKED.
- △ APPLIED ONLY FOR TERMINALS.
△ APPLIED FOR EXPOSED PAD AND TERMINALS.

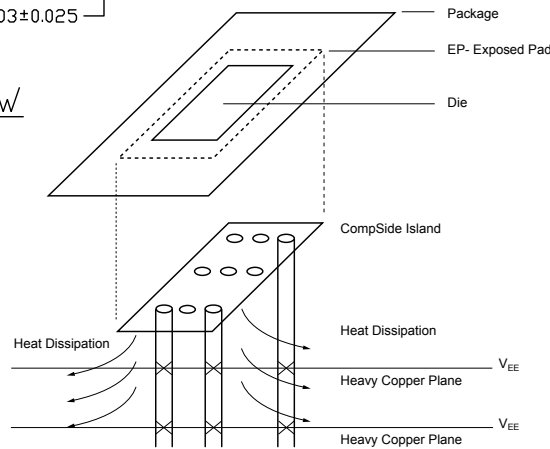

**PCB Thermal Consideration for 16-Pin MLF® Package
(Always solder, or equivalent, the exposed pad to the PCB)**

Package Notes:

1. Package meets Level 2 qualification.
2. All parts are dry-packaged before shipment.
3. Exposed pads must be soldered to a ground for proper thermal management.

MICREL, INC. 2180 FORTUNE DRIVE SAN JOSE, CA 95131 USA

TEL + 1 (408) 944-0800 FAX + 1 (408) 474-1000 WEB <http://www.micrel.com>

The information furnished by Micrel in this datasheet is believed to be accurate and reliable. However, no responsibility is assumed by Micrel for its use. Micrel reserves the right to change circuitry and specifications at any time without notification to the customer.

Micrel Products are not designed or authorized for use as components in life support appliances, devices or systems where malfunction of a product can reasonably be expected to result in personal injury. Life support devices or systems are devices or systems that (a) are intended for surgical implant into the body or (b) support or sustain life, and whose failure to perform can be reasonably expected to result in a significant injury to the user. A Purchaser's use or sale of Micrel Products for use in life support appliances, devices or systems is at Purchaser's own risk and Purchaser agrees to fully indemnify Micrel for any damages resulting from such use or sale.



Компания «ЭлектроПласт» предлагает заключение долгосрочных отношений при поставках импортных электронных компонентов на взаимовыгодных условиях!

Наши преимущества:

- Оперативные поставки широкого спектра электронных компонентов отечественного и импортного производства напрямую от производителей и с крупнейших мировых складов;
- Поставка более 17-ти миллионов наименований электронных компонентов;
- Поставка сложных, дефицитных, либо снятых с производства позиций;
- Оперативные сроки поставки под заказ (от 5 рабочих дней);
- Экспресс доставка в любую точку России;
- Техническая поддержка проекта, помощь в подборе аналогов, поставка прототипов;
- Система менеджмента качества сертифицирована по Международному стандарту ISO 9001;
- Лицензия ФСБ на осуществление работ с использованием сведений, составляющих государственную тайну;
- Поставка специализированных компонентов (Xilinx, Altera, Analog Devices, Intersil, Interpoint, Microsemi, Aeroflex, Peregrine, Syfer, Eurofarad, Texas Instrument, Miteq, Cobham, E2V, MA-COM, Hittite, Mini-Circuits, General Dynamics и др.);

Помимо этого, одним из направлений компании «ЭлектроПласт» является направление «Источники питания». Мы предлагаем Вам помощь Конструкторского отдела:

- Подбор оптимального решения, техническое обоснование при выборе компонента;
- Подбор аналогов;
- Консультации по применению компонента;
- Поставка образцов и прототипов;
- Техническая поддержка проекта;
- Защита от снятия компонента с производства.



Как с нами связаться

Телефон: 8 (812) 309 58 32 (многоканальный)

Факс: 8 (812) 320-02-42

Электронная почта: org@eplast1.ru

Адрес: 198099, г. Санкт-Петербург, ул. Калинина, дом 2, корпус 4, литера А.