

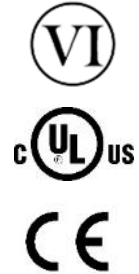

# 90W Single Port Multi-Gig Passive Power-over-Ethernet Midspan



## Features

- Single Source 4 Pair Power Current Sharing
- DoE Level VI Compliant
- ErP/Ecodesign Directive 2009/125/EC – Regulation EU 2019/1782 Compliant
- 4 Pair Power +3,6,4,5 / - 1,2,7,8
- Broken Wire Detection
- Gigabit Compatible
- Diagnostic LEDs
- Full Protection OCP, OVP
- Limited Power Source
- 1 Year Warranty

## Applications

- Satellite Receiver
- Wireless Network Access Points
- LCD Displays
- Security Cameras
- Kiosks
- Computer Workstations



# POE90-560-X Specifications<sup>1</sup>

Model		POE90U-560-R	POE90U-560-2-R	POE90U-560-5-R	POE90U-560-X-R
Output	DC Output Voltage	56.0V	56.0V	56.0V	56.0V
	Max Current	1.6A	1.6A	1.6A	1.6A
	Output Power	89.6W	89.6W	89.6W	89.6W
	Data Speed	1G	2.5G	5G	10G
	Regulation	54 - 57Vdc			
	Ripple & Noise P-P(max) <sup>2</sup>	200mV			
Input	AC Input Voltage Range	90 to 264VAC			
	AC Input Frequency	47 to 63Hz			
	Input Current	2.5A (RMS) max for 120Vac/max load; 1.2A (RMS) max for 240Vac/max load			
	Inrush Current	50A (RMS) max for 115VAC; 75A (RMS) max for 240VAC			
	No Load Power Consumption at 115VAC Input	0.038W	0.046W	0.046W	0.046W
	No Load Power Consumption at 230VAC Input	0.073W	0.107W	0.107W	0.107W
	115VAC Average Efficiency <sup>3</sup>	90.0%	89.2%	89.5%	89.2%
	230VAC Average Efficiency <sup>3</sup>	89.7%	89.1%	89.1%	89.1%
	230VAC 10% Load Efficiency <sup>3</sup>	83.3%	86.7%	86.1%	86.7%
	Leakage Current	3.5mA max for 264VAC, 50Hz			
Protection	Over-Voltage	Voltage between 2 SELV conductors shall not exceed 42.4Vpk or 60VDC for longer than 0.2seconds. Moreover a limit of 71Vpk or 120VDC shall not be exceeded. – Latching.			
	Short Circuit	The output can be shorted permanently without damage.			
	Over-Current	Output #1(OUT) <1750mA; Output #2(OUT) <1750mA Output #1 and #2 combined (OUT) <3500mA			
Environmental	Operating Temperature	-20°C to +60°C			
	Non-Operating Temperature	-20° to +65°C			
	Operating Humidity	5 to 90%			
Safety Approvals and EMC	Insulation Resistance	Primary to Secondary: >10M OHM 500VDC Primary to Field Ground: >10M OHM 500VDC			
	Standards	cULus 60950-1, cULus 62368-1, IEC60950-1, IEC 62368-1			
	EMI Emissions	FCC Part 15 Class B, CAN ICES-003(B)/NMB-003(B), EN 55032/CISPR 32 Class B Conducted and Radiated, AS/NZS 3548			
	Harmonic Current Emissions	IEC 61000-3-2			
	Voltage Fluctuations & Flicker	IEC 61000-3-3			
	Immunity	EN 55024/CISPR 24: IEC 61000-4-2, IEC 61000-4-3, IEC 61000-4-4, IEC 61000-4-5, IEC 61000-4-6, IEC 61000-4-11			
Mechanical	Dimensions (L x W x H)	166mm (6.53in) x 80mm (3.15in) x 44mm (1.73in)			
	Weight	500g			
	Output Connection	+pins 3, 6, 4, 5 / -pins 1, 2, 7, 8			
	LED Indicators	Blue Solid – Power good, “ON” output active			
Notes	<ol style="list-style-type: none"> <li>The specifications defined are at ambient temperature of 25°C, unless otherwise specified.</li> <li>20MHz bandwidth frequency oscilloscope, add a 0.1µF multilayer Cap. and Low ESR Electrolytic Cap. (10µF) at output connector terminals (nominal line voltage, full load).</li> <li>Efficiency is measured after 30 minutes burn-in.</li> </ol>				



# POE90U-560-X Outline Drawing

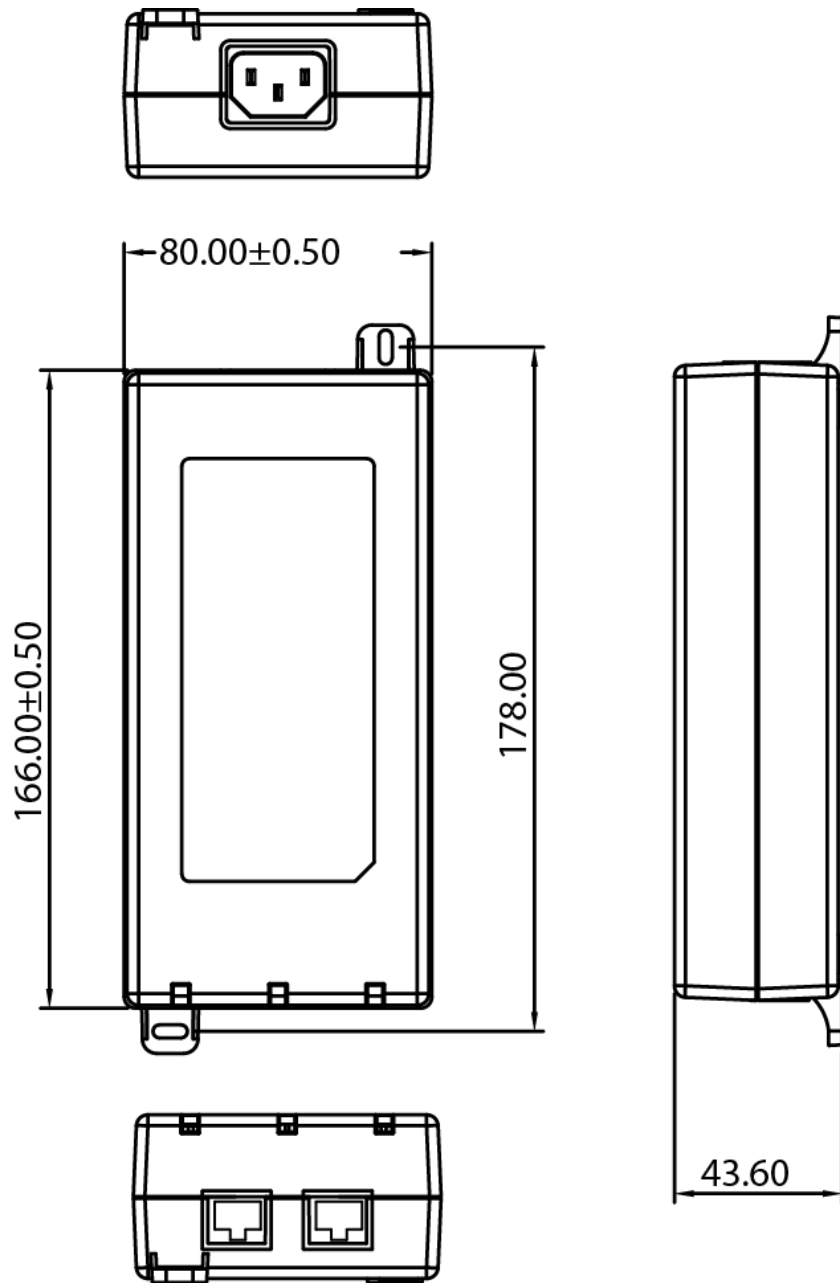

**Supplier's Declaration of Conformity**  
**47 CFR § 2.1077 Compliance Information**

Phihong USA Corporation  
47800 Fremont Boulevard  
Fremont, CA 94538  
Telephone: (510) 445-0100  
[www.phihong.com](http://www.phihong.com)

NOTE: This model has/The models in this product series have been tested and found to comply with the limits for a Class B digital device, pursuant to part 15 of the FCC Rules. These limits are designed to provide reasonable protection against harmful interference in a residential installation. This equipment generates, uses and can radiate radio frequency energy and, if not installed and used in accordance with the instructions, may cause harmful interference to radio communications. However, there is no guarantee that interference will not occur in a particular installation. If this equipment does cause harmful interference to radio or television reception, which can be determined by turning the equipment off and on, the user is encouraged to try to correct the interference by one or more of the following measures:

- Reorient or relocate the receiving antenna.
- Increase the separation between the equipment and receiver.
- Connect the equipment into an outlet on a circuit different from that to which the receiver is connected.
- Consult the dealer or an experienced radio/TV technician for help.

Changes or modifications to equipment not expressly approved by PHIHONG could void the user's authority to operate the equipment.



Компания «ЭлектроПласт» предлагает заключение долгосрочных отношений при поставках импортных электронных компонентов на взаимовыгодных условиях!

Наши преимущества:

- Оперативные поставки широкого спектра электронных компонентов отечественного и импортного производства напрямую от производителей и с крупнейших мировых складов;
- Поставка более 17-ти миллионов наименований электронных компонентов;
- Поставка сложных, дефицитных, либо снятых с производства позиций;
- Оперативные сроки поставки под заказ (от 5 рабочих дней);
- Экспресс доставка в любую точку России;
- Техническая поддержка проекта, помощь в подборе аналогов, поставка прототипов;
- Система менеджмента качества сертифицирована по Международному стандарту ISO 9001;
- Лицензия ФСБ на осуществление работ с использованием сведений, составляющих государственную тайну;
- Поставка специализированных компонентов (Xilinx, Altera, Analog Devices, Intersil, Interpoint, Microsemi, Aeroflex, Peregrine, Syfer, Eurofarad, Texas Instrument, Miteq, Cobham, E2V, MA-COM, Hittite, Mini-Circuits, General Dynamics и др.);

Помимо этого, одним из направлений компании «ЭлектроПласт» является направление «Источники питания». Мы предлагаем Вам помощь Конструкторского отдела:

- Подбор оптимального решения, техническое обоснование при выборе компонента;
- Подбор аналогов;
- Консультации по применению компонента;
- Поставка образцов и прототипов;
- Техническая поддержка проекта;
- Защита от снятия компонента с производства.



#### Как с нами связаться

**Телефон:** 8 (812) 309 58 32 (многоканальный)

**Факс:** 8 (812) 320-02-42

**Электронная почта:** [org@eplast1.ru](mailto:org@eplast1.ru)

**Адрес:** 198099, г. Санкт-Петербург, ул. Калинина, дом 2, корпус 4, литера А.