

56F8367

Evaluation Module User Manual

56F8300
16-bit Digital Signal Controllers

MC56F8367EVMUM
Rev. 2
07/2005

freescale.com

Document Revision History

Version History	Description of Change
Rev 1.0	Initial Public Release
Rev 2.0	Updated look and feel

TABLE OF CONTENTS

Preface Preface-vii

Chapter 1 Introduction

1.1	56F8367EVM Architecture	1-2
1.2	56F8367EVM Configuration Jumpers	1-3
1.3	56F8367EVM Connections	1-5

Chapter 2 Technical Summary

2.1	MC56F8367	2-4
2.2	Program and Data Memory	2-4
2.2.1	SRAM Bank 0	2-5
2.2.2	SRAM Bank 1	2-6
2.3	RS-232 Serial Communications	2-7
2.4	Clock Source	2-8
2.5	Operating Mode	2-9
2.5.1	EXTBOOT	2-9
2.5.2	EMI_MODE	2-9
2.5.3	CLKMODE	2-10
2.6	Debug LEDs	2-10
2.7	Debug Support	2-11
2.7.1	JTAG Connector	2-12
2.7.2	Parallel JTAG Interface Connector	2-13
2.8	External Interrupts	2-15
2.9	Reset	2-16
2.10	Power Supply	2-17
2.11	Daughter Card Connectors	2-18
2.11.1	Peripheral Daughter Card Connector	2-18
2.11.2	Memory Daughter Card Connector	2-20
2.12	Motor Control PWM Signals and LEDs	2-22

2.13	CAN Interfaces	2-23
2.13.1	FlexCAN #1 Interface	2-23
2.13.2	FlexCAN #2 Interface	2-24
2.14	Software Feature Jumpers	2-26
2.15	Peripheral Expansion Connectors	2-27
2.15.1	Address Bus Expansion Connector	2-28
2.15.2	Data Bus Expansion Connector	2-29
2.15.3	External Memory Control Signal Expansion Connector	2-30
2.15.4	Encoder #0 / Quad Timer Channel A Expansion Connector	2-30
2.15.5	Encoder #1 / SPI #1 Expansion Connector	2-31
2.15.6	Timer Channel C Expansion Connector	2-31
2.15.7	Timer Channel D Expansion Connector	2-32
2.15.8	A/D Port A Expansion Connector	2-33
2.15.9	A/D Port B Expansion Connector	2-34
2.15.10	Serial Communications Port #0 Expansion Connector	2-34
2.15.11	Serial Communications Port #1 Expansion Connector	2-35
2.15.12	Serial Peripheral Interface #0 Expansion Connector	2-35
2.15.13	FlexCAN #1 Expansion Connector	2-36
2.15.14	FlexCAN #2 Expansion Connector	2-36
2.15.15	PWM Port A Expansion Connector	2-37
2.15.16	PWM Port B Expansion Connector	2-37
2.16	Test Points	2-38

Appendix A
56F8367EVM Schematics

Appendix B
56F8367EVM Bill of Material

LIST OF FIGURES

1-1	Block Diagram of the 56F8367EVM	1-2
1-2	MC56F8367 Default Jumper Options	1-3
1-3	Connecting the 56F8367EVM Cables	1-5
2-1	Schematic Diagram of the External CS0 Memory Interface	2-5
2-2	Schematic Diagram of the External CS1 / CS4 Memory Interface	2-6
2-3	Schematic Diagram of the RS-232 Interface	2-7
2-4	Schematic Diagram of the Clock Interface	2-8
2-5	Schematic Diagram of the Debug LED Interface	2-11
2-6	Block Diagram of the Parallel JTAG Interface	2-13
2-7	Schematic Diagram of the User Interrupt Interface	2-15
2-8	Schematic Diagram of the Reset Interface	2-16
2-9	Schematic Diagram of the Power Supply	2-17
2-10	PWM Group A Interface and LEDs	2-22
2-11	CAN #1 Interface	2-23
2-12	CAN #2 Interface	2-25
2-13	Software Feature Jumpers	2-26
2-14	Typical Analog Input RC Filter	2-33

LIST OF TABLES

1-1	56F8367EVM Default Jumper Options	1-4
2-1	SCI #0 Jumper Options	2-7
2-2	RS-232 Serial Connector Description	2-8
2-3	EXTBOOT Operating Mode Selection	2-9
2-4	EMI Operating Mode Selection	2-9
2-5	EMI Operating Mode Selection	2-10
2-6	LED Control	2-10
2-7	JTAG Connector Description	2-12
2-8	Parallel JTAG Interface Disable Jumper Selection	2-12
2-9	Parallel JTAG Interface Connector Description	2-14
2-10	Parallel JTAG Interface Voltage Jumper Selection	2-14
2-11	Peripheral Daughter Card Connector Description	2-18
2-12	Memory Daughter Card Connector Description	2-20
2-13	CAN #1 Header Description	2-24
2-14	CAN #2 Header Description	2-25
2-15	CAN #2 Pass-Through Jumper Description	2-25
2-16	External Memory Address Bus Connector Description	2-28
2-17	External Memory Address Bus Connector Description	2-29
2-18	External Memory Control Signal Connector Description	2-30
2-19	Timer A Signal Connector Description	2-30
2-20	SPI #1 Signal Connector Description	2-31
2-21	Timer Channel C Connector Description	2-31
2-22	Timer Channel D Connector Description	2-32
2-23	A/D Port A Connector Description	2-33
2-24	A/D Port B Connector Description	2-34
2-25	SCI #0 Connector Description	2-34

2-26	SCI #1 Connector Description	2-35
2-27	SPI #0 Connector Description	2-35
2-28	CAN #1 Connector Description	2-36
2-29	CAN #2 Connector Description	2-36
2-30	PWM Port A Connector Description	2-37
2-31	PWM Port B Connector Description	2-37

Preface

This reference manual describes in detail the hardware on the 56F8367 Evaluation Module.

Audience

This document is intended for application developers who are creating software for devices using the Freescale 56F8367 part or a member of the 56F8300 family that is compatible with this part. Examples would include the 56F8346 and the 56F8357 devices.

Organization

This manual is organized into two chapters and two appendices:

- **Chapter 1, Introduction** provides an overview of the EVM and its features.
- **Chapter 2, Technical Summary** describes in detail the 56F8367 hardware.
- **Appendix A, "56F8367EVM Schematics"** contains the schematics of the MC56F8367EVM.
- **Appendix B, "56F8367EVM Bill of Material"** provides a list of the materials used on the MC56F8367EVM board.

Suggested Reading

More documentation on the 56F8367 and the MC56F8367EVM kit may be found at URL:

www.freescale.com

Notation Conventions

This manual uses the following notational conventions:

Term or Value	Symbol	Examples	Exceptions
Active High Signals (Logic One)	No special symbol attached to the signal name	A0 CLKO	
Active Low Signals (Logic Zero)	Noted with an overbar in text and in most figures	\overline{WE} OE	In schematic drawings, Active Low Signals may be noted by a backslash: /WE
Hexadecimal Values	Begin with a "\$" sym- bol	\$0FF0 \$80	
Decimal Values	No special symbol attached to the number	10 34	
Binary Values	Begin with the letter "b" attached to the number	b1010 b0011	
Numbers	Considered positive unless specifically noted as a negative value	5 -10	Voltage is often shown as positive: +3.3V
Blue Text	Linkable on-line	...refer to Chapter 7, License	
Bold	Reference sources, paths, emphasis	...see: www.freescale.com/	

Definitions, Acronyms, and Abbreviations

Definitions, acronyms and abbreviations for terms used in this document are defined below for reference.

A/D	Analog-to-Digital; a method of converting Analog signals to Digital values
ADC	Analog-to-Digital Converter; a peripheral on the 56F8367 part
CAN	Controller Area Network; serial communications peripheral and method
CiA	CAN in Automation; an international CAN user's group that coordinates standards for CAN communications protocols
D/A	Digital-to-Analog; a method of converting Digital values to an Analog form
56F8367	Controller with motor control peripherals
EOnCE	Enhanced On-Chip Emulation; a debug bus and port was created to enable a designer to create a low-cost hardware interface for a professional-quality debug environment
EVM	Evaluation Module; a hardware platform which allows a customer to evaluate the silicon and develop his application
FlexCAN	Flexible CAN Interface Module; a peripheral on the 56F8367 part
GPIO	General Purpose Input and Output port on Freescale's family of controllers; does not share pin functionality with any other peripheral on the chip and can only be set as an input, output or level-sensitive interrupt input
IC	Integrated Circuit
JTAG	Joint Test Action Group; a bus protocol/interface used for test and debug
LED	Light Emitting Diode
LQFP	Low-profile Quad Flat Package
MPIO	Multi-Purpose Input and Output port on Freescale's family of controllers; shares package pins with other peripherals on the chip and can function as a GPIO
OnCE™	On-Chip Emulation, a debug bus and port created to allow a means for low-cost hardware to provide a professional-quality debug environment
PCB	Printed Circuit Board
PLL	Phase Locked Loop
PWM	Pulse Width Modulation
QuadDec	Quadrature Decoder; a peripheral on the 56F8367 part

RAM	Random Access Memory
R/C	Resistor/Capacitor Network
ROM	Read-Only Memory
SCI	Serial Communications Interface; a peripheral on Freescale's family of controllers
SPI	Serial Peripheral Interface; a peripheral on Freescale's family of controllers
SRAM	Static Random Access Memory
WS	Wait State

References

The following sources were referenced to produce this manual:

- [1] *DSP56800E Reference Manual*, DSP56800ERM, Freescale Semiconductor
- [2] *56F8300 Peripheral User Manual*, MC56F8300UM, Freescale Semiconductor
- [3] *56F8367 Technical Data*, MC56F8367, Freescale Semiconductor
- [4] *CiA Draft Recommendation DR-303-1, Cabling and Connector Pin Assignment*, Version 1.0, CAN in Automation
- [5] *CAN Specification 2.0B*, BOSCH or CAN in Automation

Chapter 1

Introduction

The 56F8367EVM is used to demonstrate the abilities of the 56F8367 controller and to provide a hardware tool allowing the development of applications.

The 56F8367EVM is an evaluation module board that includes a 56F8367 part, peripheral expansion connectors, a CAN interface, 512KB of external memory and a pair of daughter card connectors. The daughter card connectors are for signal monitoring and user feature expandability.

The 56F8367EVM is designed for the following purposes:

- Allowing new users to become familiar with the features of the 56800E architecture. The tools and examples provided with the 56F8367EVM facilitate evaluation of the feature set and the benefits of the family.
- Serving as a platform for real-time software development. The tool suite enables the user to develop and simulate routines, download the software to on-chip or on-board RAM, run it, and debug it using a debugger via the JTAG/Enhanced OnCE (EOnCE) port. The breakpoint features of the EOnCE port enable the user to easily specify complex break conditions and to execute user-developed software at full speed until the break conditions are satisfied. The ability to examine and modify all user-accessible registers, memory and peripherals through the EOnCE port greatly facilitates the task of the developer.
- Serving as a platform for hardware development. The hardware platform enables the user to connect external hardware peripherals. The on-board peripherals can be disabled, providing the user with the ability to reassign any and all of the processor's peripherals. The EOnCE port's unobtrusive design means that all memory on the board and on the processor is available to the user.

1.1 56F8367EVM Architecture

The 56F8367EVM facilitates the evaluation of various features present in the 56F8367 part. The 56F8367EVM can be used to develop real-time software and hardware products. The 56F8367EVM provides the features necessary for a user to write and debug software, demonstrate the functionality of that software and interface with the user's application-specific device(s). The 56F8367EVM is flexible enough to allow a user to fully exploit the 56F8367's features to optimize the performance of his product, as shown in [Figure 1-1](#).

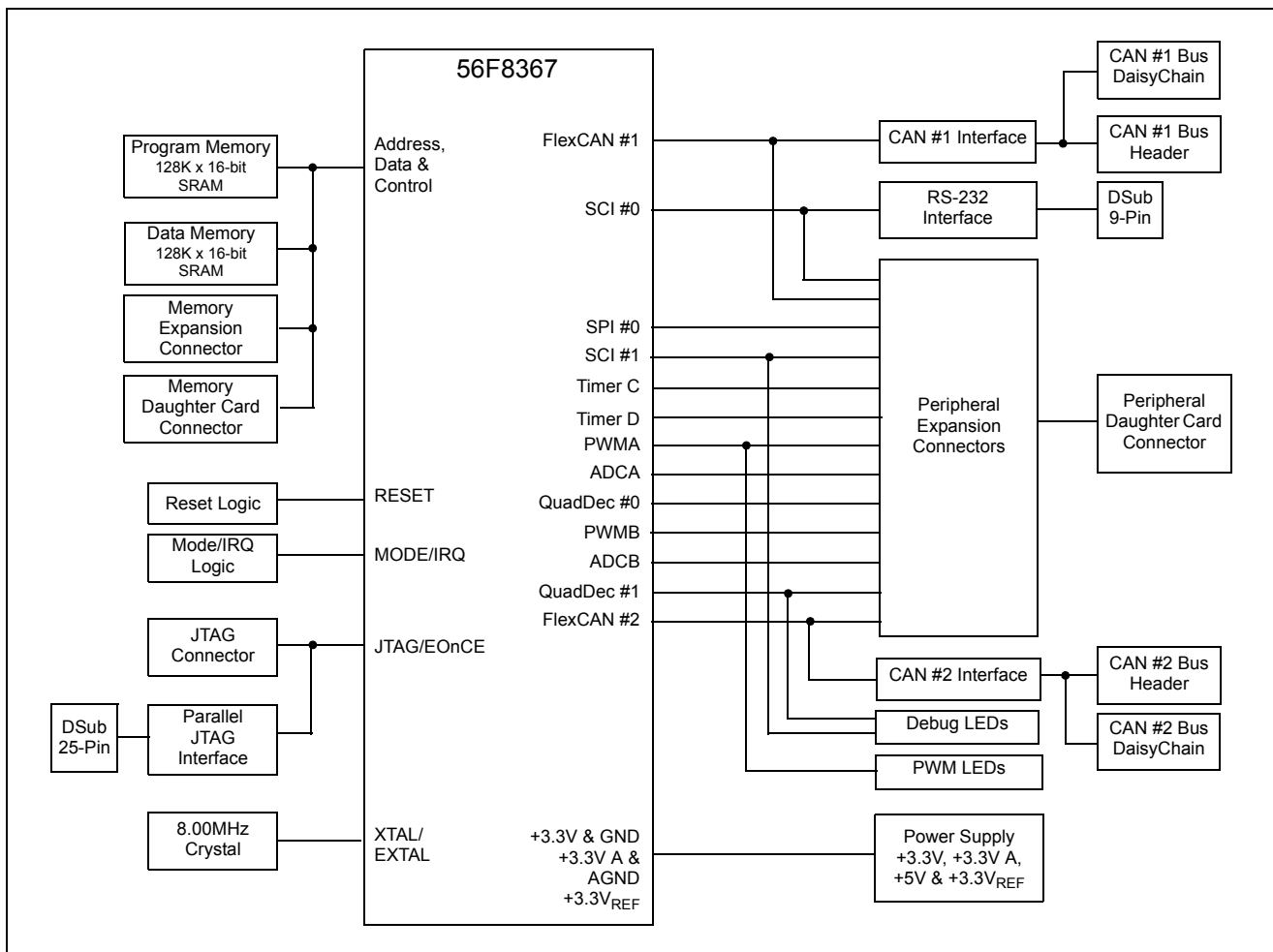

Figure 1-1. Block Diagram of the 56F8367EVM

1.2 56F8367EVM Configuration Jumpers

Nineteen jumper groups, (JG1-JG19), shown in [Figure 1-2](#), are used to configure various features on the 56F8367EVM board. [Table 1-1](#) describes the default jumper group settings.

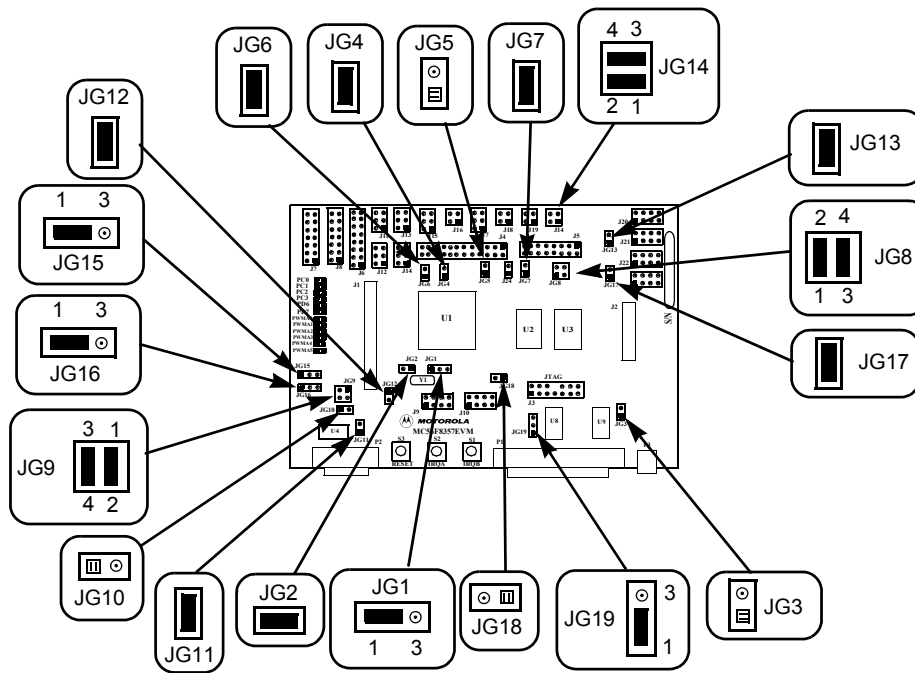

Figure 1-2. MC56F8367 Default Jumper Options

Table 1-1. 56F8367EVM Default Jumper Options

Jumper Group	Comment	Jumpers Connections
JG1	Use on-board EXTAL crystal input for oscillator	1-2
JG2	Use on-board XTAL crystal input for oscillator	1-2
JG3	Enable on-board Parallel JTAG Host/Target Interface	NC
JG4	Enable Internal Boot Mode	1-2
JG5	Enable A0 - A23 for external memory accesses	NC
JG6	Enable Crystal Mode	1-2
JG7	Enable SRAM Memory Bank 0 (use CS0)	1-2
JG8	Enable SRAM Memory Bank 1 (use CS1 & CS4)	1-2 & 3-4
JG9	Pass RXD0 & TXD0 to RS-232 level converter	1-2 & 3-4
JG10	Enable RS-232 output	NC
JG11	Pass RS-232 RST to CTS	1-2
JG12	Pass Temperature Diode to ANA7	1-2
JG13	CAN #1 termination selected	1-2
JG14	Pass CAN2_TX & CAN2_RX to CAN transceiver	1-2 & 3-4
JG15	High selected on User Jumper #0	1-2
JG16	High selected on User Jumper #1	1-2
JG17	CAN2 termination selected	1-2
JG18	Analog Ground to Digital Ground not reconnected	NC
JG19	Use +3.3V for Printer Interface to on-board Parallel JTAG Host/Target	1-2

1.3 56F8367EVM Connections

An interconnection diagram is shown in [Figure 1-3](#) for connecting the PC and the external +12.0V DC/AC power supply to the 56F8367EVM board.

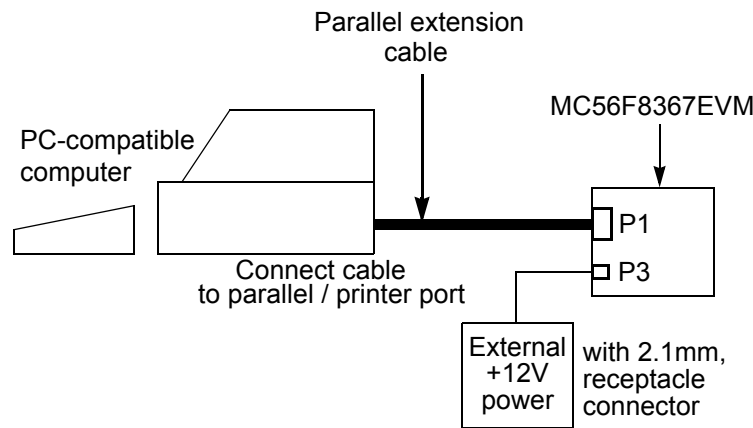

Figure 1-3. Connecting the 56F8367EVM Cables

Perform the following steps to connect the 56F8367EVM cables:

1. Connect the parallel extension cable to the parallel port of the host computer.
2. Connect the other end of the parallel extension cable to P1, shown in [Figure 1-3](#), on the 56F8367EVM board. This provides the connection which allows the host computer to control the board.
3. Make sure that the external +12V DC, 1.2A power supply is not plugged into a +120V AC power source.
4. Connect the 2.1mm output power plug from the external power supply into P3, shown in [Figure 1-3](#), on the 56F8367EVM board.
5. Apply power to the external power supply. The green Power-On LED, LED13, will illuminate when power is correctly applied.

Chapter 2

Technical Summary

The 56F8367EVM is designed as a versatile development card using the 56F8367 processor, allowing the creation of real-time software and hardware products to support a new generation of applications in servo and motor control, digital and wireless messaging, digital answering machines, feature phones, modems, and digital cameras. The power of the 16-bit 56F8367 processor, combined with the on-board 128K x 16-bit external Program/Data Static RAM (SRAM), 128K x 16-bit external Data/Program SRAM, RS-232 interface, CAN interface, daughter card interface, peripheral expansion connectors and parallel JTAG interface, makes the 56F8367EVM ideal for developing and implementing many motor controlling algorithms, as well as for learning the architecture and instruction set of the 56F8367 processor.

The main features of the 56F8367EVM, with board and schematic reference designators, include:

- MC56F8367VPY60, a 16-bit +3.3V/+2.5V controller operating at 60MHz [U1]
- External Fast Static RAM (FSRAM) memory, configured as:
 - 128K x 16-bit of memory [U2] with 0 wait state at 60MHz via CS0
 - 128K x 16-bit of memory [U3] with 0 wait state at 60MHz via CS1/CS4
- 8.00MHz crystal oscillator, for base processor frequency generation [Y1]
- Optional external oscillator frequency input connectors [JG1 and JG2]
- Joint Test Action Group (JTAG) port interface connector, for an external debug Host Target Interface [J3]
- On-board parallel JTAG host target interface, with a connector for a PC printer port cable [P1], including a disable jumper [JG3] and a printer port voltage selection jumper [JG19]
- RS-232 interface, for easy connection to a host processor [U4 and P2], including a disable jumper [JG10]
- RTS and CTS RS-232 control signal access [JG11]
- CAN interface, for high speed, 1.0Mbps, FlexCAN communications [U10 and J20]
- CAN bypass and bus termination [J21 and JG13]



- CAN #2 interface, for high speed, 1.0Mbps, FlexCAN communications [U11 and J22]
- CAN #2 bypass and bus termination [J23 and JG17]
- CAN #2 interface signal isolation [JG14]
- Peripheral Daughter Card connector, to allow the user to connect his own SCI, SPI or GPIO-compatible peripheral to the controller [J1]
- Memory Daughter Card connector, to allow the user to connect his own memory or memory device to the device [J2]
- SCI #0 expansion connector, to allow the user to connect his own SCI #0 / MPIO-compatible peripheral [J13]
- SCI #1 expansion connector, to allow the user to connect his own SCI #1 / MPIO-compatible peripheral [J14]
- SPI #0 expansion connector, to allow the user to connect his own SPI #0 / MPIO-compatible peripheral [J11]
- SPI #1 expansion connector, to allow the user to connect his own SPI #1 / MPIO-compatible peripheral [J12]
- PWMA expansion connector, to allow the user to connect his own PWMA-compatible peripheral [J7]
- PWMB expansion connector, to allow the user to connect his own PWMB-compatible peripheral [J8]
- CAN #1 expansion connector, to allow the user to connect his own CAN physical layer peripheral [J18]
- CAN #2 expansion connector, to allow the user to connect his own CAN physical layer peripheral [J19]
- Timer A expansion connector, to allow the user to connect his own Timer A / Encoder #0-compatible peripheral [J15]
- Timer C expansion connector, to allow the user to connect his own Timer C-compatible peripheral [J16]
- Timer D expansion connector, to allow the user to connect his own Timer D-compatible peripheral [J17]
- ADC A expansion connector, to allow the user to attach his own A/D Port A-compatible peripheral [J9]
- ADC B expansion connector, to allow the user to attach his own A/D Port B-compatible peripheral [J10]

- Address bus expansion connector, to allow the user to monitor the external address bus [J4]
- Data bus expansion connector, to allow the user to monitor the external data bus [J5]
- External memory bus control signal connector, to allow the user to monitor the external memory bus [J6]
- On-board power regulation provided from an external +12V DC-supplied power input [P3]
- Light Emitting Diode (LED) power indicator [LED13]
- Six on-board real-time user debugging LEDs [LED1 - 6]
- Six on-board Port A PWM monitoring LEDs [LED7 - 12]
- Internal/external (EXTBOOT) boot mode selector [JG4]
- Address range (EMI_MODE) boot mode selector [JG5]
- Clock mode (CLKMODE) boot selector [JG6]
- Temperature sense diode to ANA7 selector [JG12]
- Manual reset push button [S1]
- Manual interrupt push button for $\overline{\text{IRQA}}$ [S2]
- Manual interrupt push button for $\overline{\text{IRQB}}$ [S3]
- General-purpose jumper on GPIO PE4 [JG15]
- General-purpose jumper on GPIO PE7 [JG16]

2.1 MC56F8367

The 56F8367EVM uses a Freescale MC56F8367VPY60 part, designated as U1 on the board and in the schematics. This part will operate at a maximum external bus speed of 60MHz. A full description of the 56F8367, including functionality and user information, is provided in these documents:

- *56F8367 Technical Data Sheet, (MC56F8367)*: Electrical and timing specifications, pin descriptions, device-specific peripheral information and package descriptions (this document)
- *56F8300 Peripheral User Manual, (MC56F8300UM)*: Detailed description of peripherals of the 56F8300 family of devices
- *DSP56800E Reference Manual, (DSP56800ERM)*: Detailed description of the 56800E family architecture, 16-bit core processor, and the instruction set

Refer to these documents for detailed information about chip functionality and operation. They can be found on this URL:

www.freescale.com

2.2 Program and Data Memory

The 56F8367EVM contains two 128K x 16-bit Fast Static RAM banks. SRAM bank 0 is controlled by CS0 and SRAM bank 1 is controlled by CS1 and CS4. This provides a total of 256K x 16 bits of external memory.

2.2.1 SRAM Bank 0

SRAM bank 0, which is controlled by CS0, uses a 128K x 16-bit Fast Static RAM (GSI GS72116, labeled U2) for external memory expansion; see the FSRAM schematic diagram in [Figure 2-1](#). CS0 can be configured to use this memory bank as 16 bits of Program memory, Data memory, or both. Additionally, CS0 can be configured to assign this memory's size and starting address to any modulo address space.

This memory bank will operate with zero wait state access while the 56F8367 is running at 60MHz and can be disabled by removing the jumper at JG7.

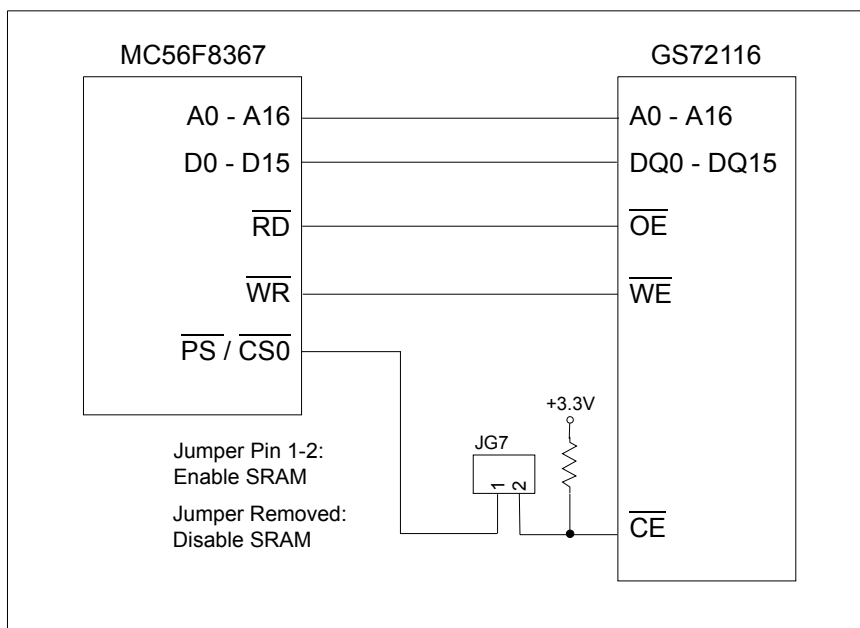

Figure 2-1. Schematic Diagram of the External CS0 Memory Interface

2.2.2 SRAM Bank 1

SRAM bank 1, which is controlled by CS1 and CS2, uses a 128K x 16-bit Fast Static RAM (GSI GS72116, labeled U3) for external memory expansion; see the FSRAM schematic diagram in [Figure 2-2](#). Using CS1 and CS4, this memory bank can be configured as byte (8-bit) or word (16-bit) accessible Program memory, Data memory, or both. Additionally, CS1 and CS4 can be configured to assign this memory's size and starting address to any modulo address space.

This memory bank will operate with zero wait state access while the 56F8367 is running at 60MHz and can be disabled by removing the jumpers at JG8.

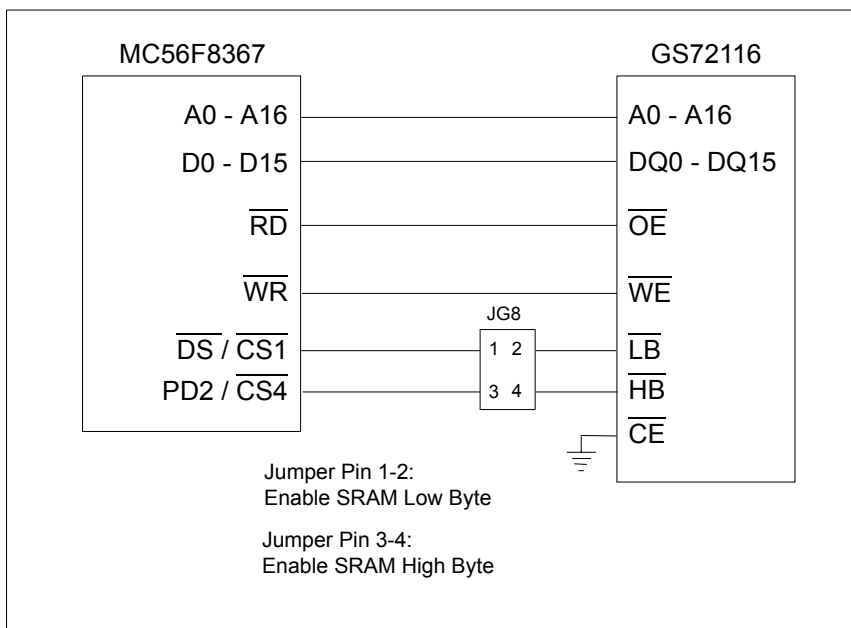

Figure 2-2. Schematic Diagram of the External CS1 / CS4 Memory Interface

2.3 RS-232 Serial Communications

The 56F8367EVM provides an RS-232 interface by the use of an RS-232 level converter, Maxim MAX3245EEAI, designated as U4. Refer to the RS-232 schematic diagram in **Figure 2-3**. The RS-232 level converter transitions the SCI port's +3.3V signal levels to RS-232-compatible signal levels and connects to the host's serial port via connector P2. RTS/CTS flow control is provided on JG11 as a jumper, but could be implemented using uncommitted GPIO signals. The SCI port #0 signals can be isolated from the RS-232 level converter by removing the jumpers in JG9; see **Table 2-1**. The pin-out of connector P2 is listed in **Table 2-2**. The RS-232 level converter/transceiver can be disabled by placing a jumper at JG10.

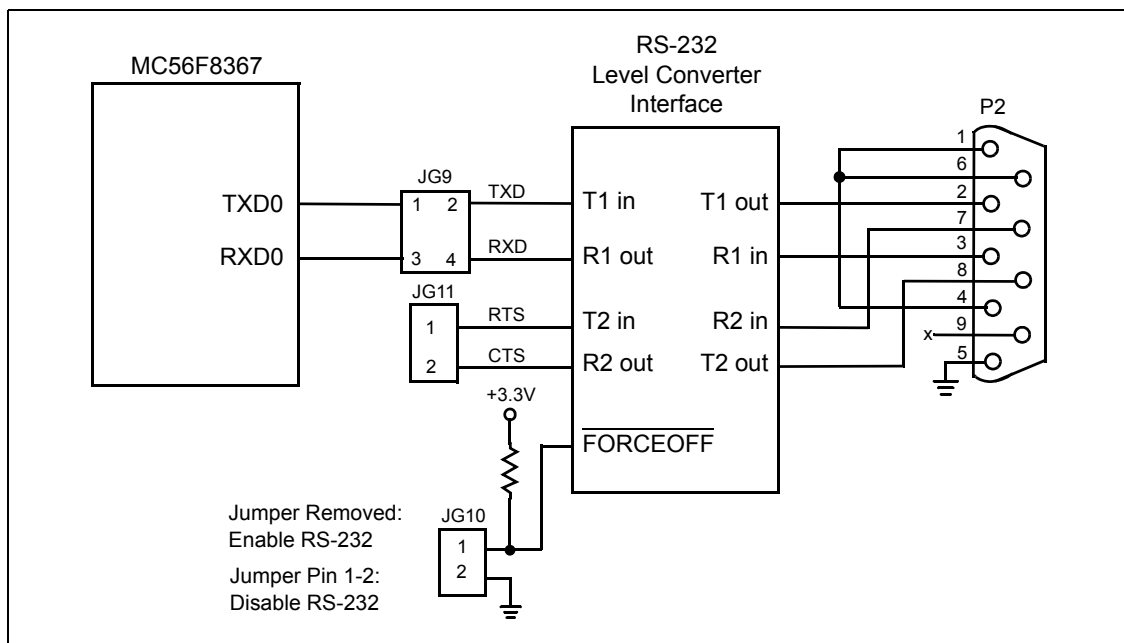

Figure 2-3. Schematic Diagram of the RS-232 Interface

Table 2-1. SCI #0 Jumper Options

JG9			
Pin #	Signal	Pin #	Signal
1	TXD0	2	RS-232 TXD
3	RXD0	4	RS-232 RXD

Table 2-2. RS-232 Serial Connector Description

P2			
Pin #	Signal	Pin #	Signal
1	Jumper to 6 & 4	6	Jumper to 1 & 4
2	TXD	7	CTS
3	RXD	8	RTS
4	Jumper to 1 & 6	9	NC
5	GND		

2.4 Clock Source

The 56F8367EVM uses an 8.00MHz crystal, Y1, connected to its external crystal inputs, EXTAL and XTAL. To achieve its maximum internal operating frequency, the 56F8367 uses its internal PLL to multiply the input frequency. An external oscillator source can be connected to the processor by using the oscillator bypass connectors, JG1 and JG2; see [Figure 2-4](#). If the input frequency is above 8MHz, then the EXTAL input should be jumpered to ground by adding a jumper between JG1 pins 2 and 3. The input frequency would then be injected on JG2's pin 2. If the input frequency is below 4MHz, then the input frequency can be injected on JG1's pin 2.

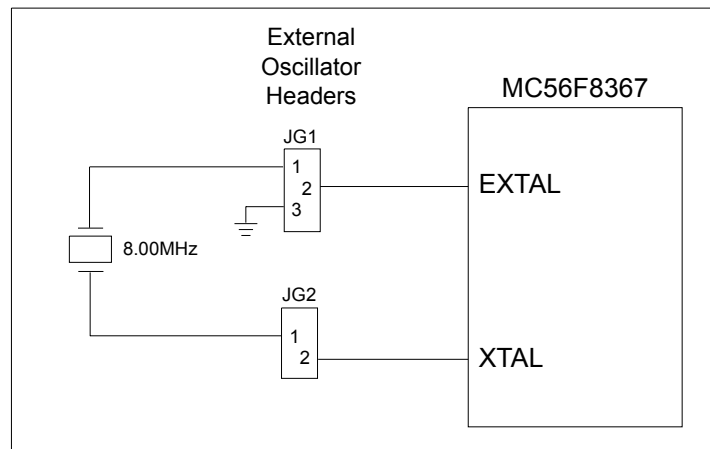

Figure 2-4. Schematic Diagram of the Clock Interface

2.5 Operating Mode

The 56F8367EVM provides three boot mode selection jumpers, EXTBOOT, EMI_MODE and CLKMODE, to provide boot-up mode options.

2.5.1 EXTBOOT

The 56F8367EVM provides an external/internal boot mode jumper, JG4. This jumper is used to select the internal or external memory operation of the processor as it exits reset. Refer to the **56F8300 Peripheral User Manual** and the **56F8367 Technical Data Sheet** for a complete description of the chip's operating modes. **Table 2-3** shows the two external boot operation modes available on the 56F8367.

Table 2-3. EXTBOOT Operating Mode Selection

Operating Mode	JG4	Comment
0	1 - 2	Bootstrap from internal memory (GND)
3	No Jumper	Bootstrap from external memory (+3.3V)

2.5.2 EMI_MODE

The 56F8367EVM provides an EMI boot mode jumper, JG5. This jumper is used to select the external memory addressing range operating mode of the processor as it exits reset. The user can select between a 64K address space or an 8M address space. Refer to the **56F8300 Peripheral User Manual** and the **56F8367 Technical Data Sheet** for a complete description of the chip's operating modes. **Table 2-4** shows the two EMI operation modes available on the 56F8367.

Table 2-4. EMI Operating Mode Selection

Operating Mode	JG5	Comment
V1	1 - 2	A0 - A15 (64K) available for external memory bus (GND)
V2	No Jumper	A0 - A23 (8M) available for external memory bus (+3.3V)

2.5.3 CLKMODE

The 56F8367EVM provides a clock boot mode jumper, JG6. This jumper is used to select the type of clock source being provided to the processor as it exits reset. The user can select between the use of a crystal or an oscillator as the clock source for the processor. Refer to the **56F8300 Peripheral User Manual** and the **56F8367 Technical Data Sheet** for a complete description of the chip's operating modes. **Table 2-5** shows the two CLKMODE operation modes available on the 56F8367.

Table 2-5. EMI Operating Mode Selection

Operating Mode	JG6	Comment
Crystal	1 - 2	Enables the external clock drive logic so an external crystal can be used as the input clock source. (GND)
Oscillator	No Jumper	Disables the external clock drive logic. Use oscillator input on XTAL and Ground on EXTAL. (3.3V)

2.6 Debug LEDs

Six on-board Light Emitting Diodes, (LEDs), are provided to allow real-time debugging for user programs. These LEDs will allow the programmer to monitor program execution without having to stop the program during debugging; refer to **Figure 2-5**. **Table 2-6** describes the control of each LED.

Table 2-6. LED Control

User LED	Controlled by	
	Color	Signal
LED1	RED	Port C Bit 0 (PC0)
LED2	YELLOW	Port C Bit 1 (PC1)
LED3	GREEN	Port C Bit 2 (PC2)
LED4	RED	Port C Bit 3 (PC3)
LED5	YELLOW	Port D Bit 6 (PD6)
LED6	GREEN	Port D Bit 7 (PD7)

Setting PC0, PC1, PC2, PC3, PD6, or PD7 to a Logic One value will turn on the associated LED.

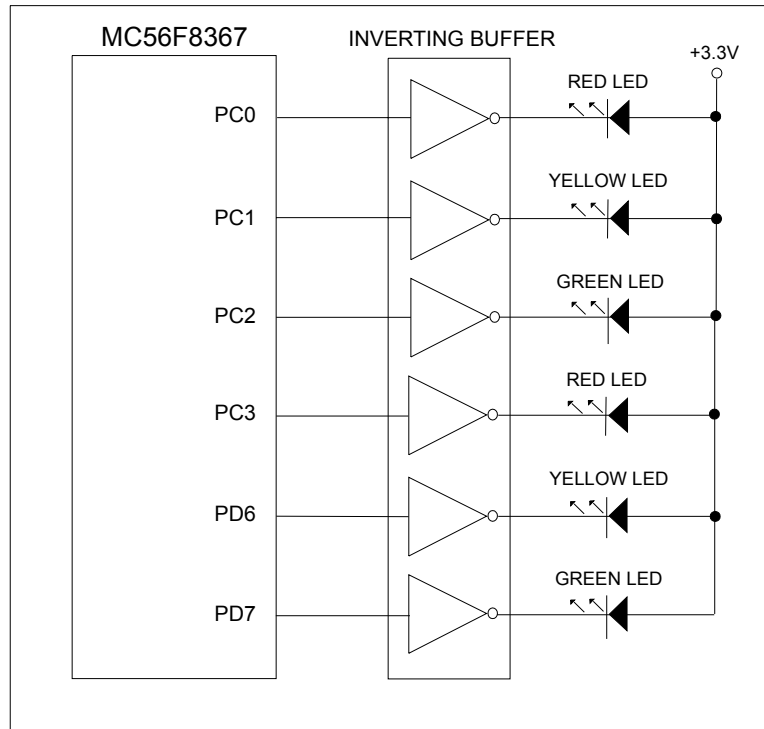

Figure 2-5. Schematic Diagram of the Debug LED Interface

2.7 Debug Support

The 56F8367EVM provides an on-board parallel JTAG host target interface and a JTAG interface connector for external target interface support. Two interface connectors are provided to support each of these debugging approaches. These two connectors are designated the JTAG connector and the host parallel interface connector.

2.7.1 JTAG Connector

The JTAG connector on the 56F8367EVM allows the connection of an external host target interface for downloading programs and working with the 56F8367's registers. This connector is used to communicate with an external host target interface, which passes information and data back and forth with a host processor running a debugger program. [Table 2-7](#) shows the pin-out for this connector.

Table 2-7. JTAG Connector Description

J3			
Pin #	Signal	Pin #	Signal
1	TDI	2	GND
3	TDO	4	GND
5	TCK	6	GND
7	NC	8	KEY
9	$\overline{\text{RESET}}$	10	TMS
11	+3.3V	12	NC
13	$\overline{\text{DE}}$	14	$\overline{\text{TRST}}$

When this connector is used with an external host target interface, the parallel JTAG interface should be disabled by placing a jumper in jumper block JG3. Reference [Table 2-8](#) for this jumper's selection options.

Table 2-8. Parallel JTAG Interface Disable Jumper Selection

JG3	Comment
No jumpers	Enables On-board Parallel JTAG Interface
1 - 2	Disables on-board Parallel JTAG Interface

2.7.2 Parallel JTAG Interface Connector

The Parallel JTAG Interface Connector, P1, allows the 56F8367 to communicate with a parallel printer port on a Windows PC; reference [Figure 2-6](#). Using this connector, the user can download programs and work with the 56F8367's registers. [Table 2-9](#) shows the pin-out for this connector. When using the parallel JTAG interface, the jumper at JG3 should be removed, as shown in [Table 2-8](#). The printer port interface voltage of +3.3V or +5.0V can be selected by a jumper on JG19, as shown in [Table 2-10](#).

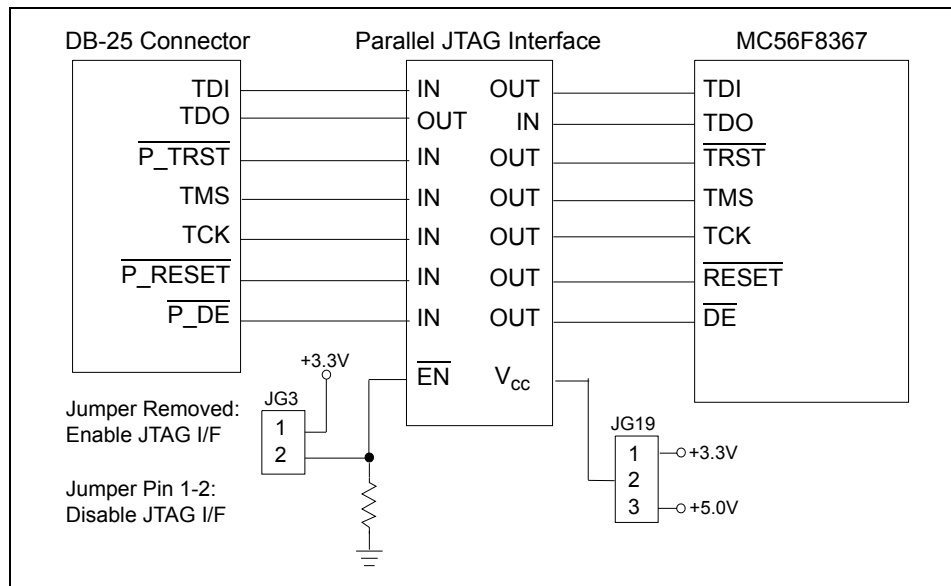

Figure 2-6. Block Diagram of the Parallel JTAG Interface

Table 2-9. Parallel JTAG Interface Connector Description

P1			
Pin #	Signal	Pin #	Signal
1	NC	14	NC
2	PORT_RESET	15	PORT_IDENT
3	PORT_TMS	16	NC
4	PORT_TCK	17	NC
5	PORT_TDI	18	GND
6	$\overline{\text{PORT_TRST}}$	19	GND
7	$\overline{\text{PORT_DE}}$	20	GND
8	PORT_IDENT	21	GND
9	PORT_VCC	22	GND
10	NC	23	GND
11	PORT_TDO	24	GND
12	NC	25	GND
13	PORT_CONNECT		

Table 2-10. Parallel JTAG Interface Voltage Jumper Selection

JG19	Comment
1 - 2	Interface with the PC's printer port using +3.3V signals
2 - 3	Interface with the PC's printer port using +5.0V signals

2.8 External Interrupts

Two on-board push button switches are provided for external interrupt generation, as shown in [Figure 2-7](#). S2 allows the user to generate a hardware interrupt for signal line $\overline{\text{IRQA}}$. S3 allows the user to generate a hardware interrupt for signal line $\overline{\text{IRQB}}$. These two switches allow the user to generate interrupts for his user-specific programs.

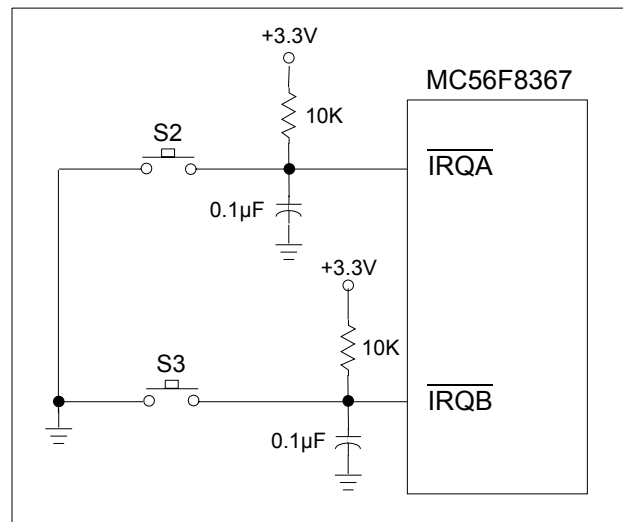

Figure 2-7. Schematic Diagram of the User Interrupt Interface

2.9 Reset

Logic is provided on the 56F8367 to generate an internal power-on reset. Additional reset logic is provided to support the reset signals from the JTAG connector, the parallel JTAG interface and the user reset push button, S1; refer to [Figure 2-8](#).

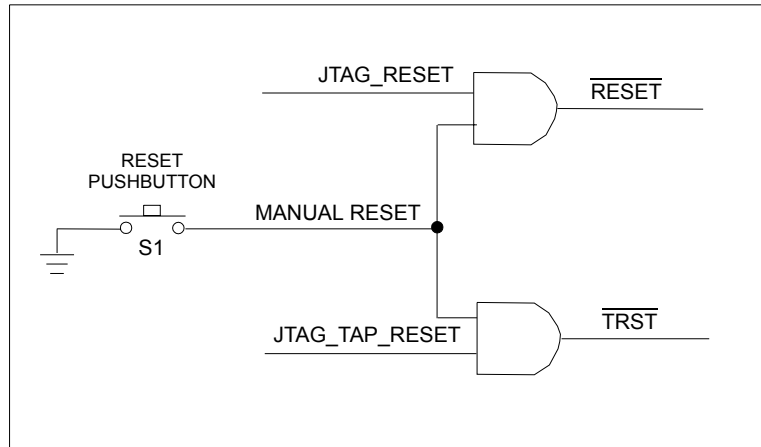

Figure 2-8. Schematic Diagram of the Reset Interface

2.10 Power Supply

The main power input to the 56F8367EVM, +12V DC at 1.2A, is through a 2.1mm coax power jack. This input power is rectified to provide a DC supply input. This allows a user the option to use a +12V AC power supply. A 1.2 Amp power supply is provided with the 56F8367EVM; however, less than 500mA is required by the EVM. The remaining current is available for custom control applications when connected to the daughter card connectors. The 56F8367EVM provides +5.0V DC regulation for the CAN interface and additional regulators. The 56F8367EVM provides +3.3V DC voltage regulation for the processor, memory, D/A, ADC, parallel JTAG interface and supporting logic; refer to [Figure 2-9](#). Additional voltage regulation logic provides a low-noise +3.3V DC voltage reference to the processor's A/D V_{REFH} . A jumper, JG18, and resistor, R66, are provided to allow the analog and digital grounds to be isolated on the 56F8367EVM board. This allows the analog ground reference point to be provided on a custom board attached to the 56F8367EVM daughter card connectors. By removing R66, the AGND reference is disconnected from the 56F8367EVM's digital ground. By placing a jumper on JG18, the AGND is reconnected to the 56F8367EVM's digital ground. Power applied to the 56F8367EVM is indicated with a power-on LED, referenced as LED13. Optionally, the user can provide the +2.5V DC voltage needed by the processor's core on connector J24 and disable the on-chip core voltage regulator by moving the resistor at R72 to R71. Additionally, four zero ohm resistors or shorting wires must be added at R67, R68, R69, and R70 to allow the external +2.5V DC to pass to the 56F8367.

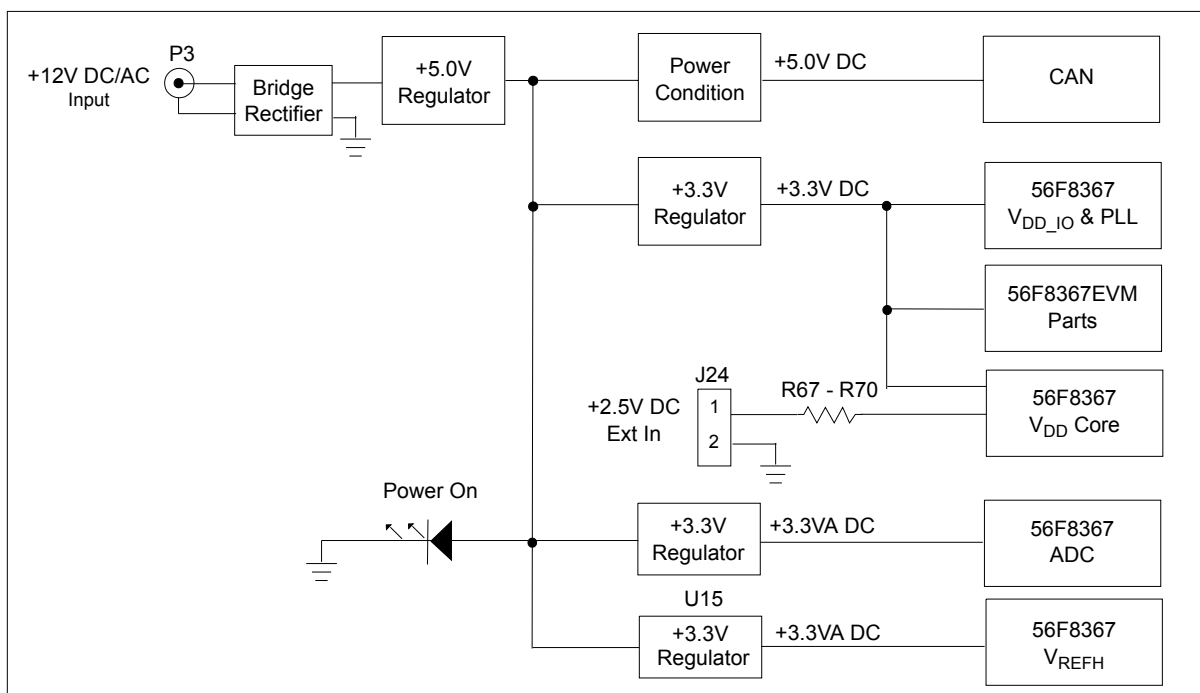

Figure 2-9. Schematic Diagram of the Power Supply

2.11 Daughter Card Connectors

The EVM board contains two daughter card connectors. One connector, J1, contains the processor's peripheral port signals. The second connector, J2, contains the processor's external memory bus signals.

2.11.1 Peripheral Daughter Card Connector

The processor's peripheral port signals are connected to the peripheral daughter card connector, J1. The peripheral daughter card connector is used to connect a daughter card or a user-specific daughter card to the processor's peripheral port signals. The peripheral port daughter card connector is a 100-pin high-density connector with signals for the IRQs, reset, SPI, SCI, PWM, ADC and Quad Timer ports. [Table 2-11](#) shows the peripheral daughter card connector's signal-to-pin assignments.

Table 2-11. Peripheral Daughter Card Connector Description

J1			
Pin #	Signal	Pin #	Signal
1	+12V	2	+12V
3	GND	4	GND
5	+5.0V	6	+5.0V
7	GND	8	GND
9	+3.3V	10	+3.3V
11	GND	12	GND
13	PHASEA0 / TA0 / PC4	14	PHASEB0 / TA1 / PC5
15	INDEX0 / TA2 / PC6	16	HOME0 / TA3 / PC7
17	GND	18	GND
19	PHASEA1 / PC0 / TB0 / SCLK1	20	PHASEB1 / PC1 / TB1 / MOSI1
21	INDEX1 / PC2 / TB2 / MISO1	22	HOME1 / PC3 / TB3 / $\overline{SS1}$
23	TXD0 / PE0	24	TXD1 / PD6
25	TXD0 / PE0	26	TXD1 / PD6
27	RXD0 / PE1	28	RXD1 / PD7

Table 2-11. Peripheral Daughter Card Connector Description (Continued)

J1			
Pin #	Signal	Pin #	Signal
29	$\overline{\text{IRQA}}$	30	$\overline{\text{IRQB}}$
31	RXD0 / PE1	32	RXD1 / PD7
33	PWMB0	34	PWMB1
35	PWMB2	36	PWMB3
37	PWMB4	38	PWMB5
39	GND	40	GND
41	ISB0 / PD10	42	ISB1 / PD11
43	ISB2 / PD12	44	GND
45	FAULTB1	46	FAULTB0
47	FAULTB3	48	FAULTB2
49	GND	50	GND
51	PWMA0	52	PWMA1
53	PWMA2	54	PWMA3
55	PWMA4	56	PWMA5
57	GND	58	GND
59	FAULTA0	60	FAULTA1
61	FAULTA2	62	MISO0 / PE6
63	ISA0 / PC8	64	ISA1 / PC9
65	ISA2 / PC10	66	$\overline{\text{RSTO}}$
67	MOSI0 / PE5	68	$\overline{\text{SS0}} / \text{PE7}$
69	TD0 / PE10	70	TD1 / PE11
71	SCLK0 / PE7	72	TC0 / PE8
73	CAN_TX	74	CAN_RX
75	MOSI0 / PE5	76	MISO0 / PE6
77	SCLK0 / PE4	78	$\overline{\text{SS0}} / \text{PE7}$
79	GND	80	GND

Table 2-11. Peripheral Daughter Card Connector Description (Continued)

J1			
Pin #	Signal	Pin #	Signal
81	+V _{REFH}	82	+V _{REFH}
83	GND _A	84	GND _A
85	AN0	86	AN1
87	AN2	88	AN3
89	AN4	90	AN5
91	AN6	92	AN7
93	AN8	94	AN9
95	AN10	96	AN11
97	AN12	98	AN13
99	AN14	100	AN15

2.11.2 Memory Daughter Card Connector

The processor's external memory bus signals are connected to the memory daughter card connector, J2. [Table 2-12](#) shows the port signal-to-pin assignments.

Table 2-12. Memory Daughter Card Connector Description

J2			
Pin #	Signal	Pin #	Signal
1	A4 / PA12	2	A5 / PA13
3	A3 / PA11	4	A6 / PE2
5	A2 / PA10	6	A7 / PE3
7	A1 / PA9	8	$\overline{\text{RD}}$
9	GND	10	GND
11	A0 / PA8	12	$\overline{\text{DS}} / \overline{\text{CS}}1$
13	$\overline{\text{PS}} / \overline{\text{CS}}0$	14	PD0 / $\overline{\text{CS}}2$ / CAN2_TX

Table 2-12. Memory Daughter Card Connector Description (Continued)

J2			
Pin #	Signal	Pin #	Signal
15	D0 / PF9	16	D15 / PF8
17	D1 / PF10	18	D14 / PF7
19	GND	20	GND
21	GND	22	GND
23	D2 / PF11	24	D13 / PF6
25	D3 / PF12	26	D12 / PF5
27	D4 / PF13	28	D11 / PF4
29	D5 / PF14	30	D10 / PF3
31	GND	32	GND
33	GND	34	GND
35	D6 / PF15	36	D9 / PF2
37	D7 / PF0	38	D8 / PF1
39	$\overline{\text{WR}}$	40	PD1 / $\overline{\text{CS3}}$ / CAN2_RX
41	A15 / PA7	42	A8 / PA0
43	GND	44	GND
45	A14 / PA6	46	A9 / PA1
47	A13 / PA5	48	A10 / PA2
49	A12 / PA4	50	A11 / PA3
51	PB0 / A16	52	GND
53	GND	54	GND
55	+3.3V	56	+3.3V
57	GND	58	GND
59	+5.0V	60	+5.0V

2.12 Motor Control PWM Signals and LEDs

The 56F8367 has two independent groups of dedicated PWM units. Each unit contains six PWM, three phase current sense inputs and four fault input lines. PWM group A's PWM lines are connected to a set of six PWM LEDs via inverting buffers. The buffers are used to isolate and drive the Processor's PWM group A's outputs to the PWM LEDs. The PWM LEDs indicate the status of PWM group A signals; refer to [Figure 2-10](#). PWM Group A and B signals are routed out to headers, J7 and J8 respectively, and to the peripheral daughter card connector for easy use by the end user.

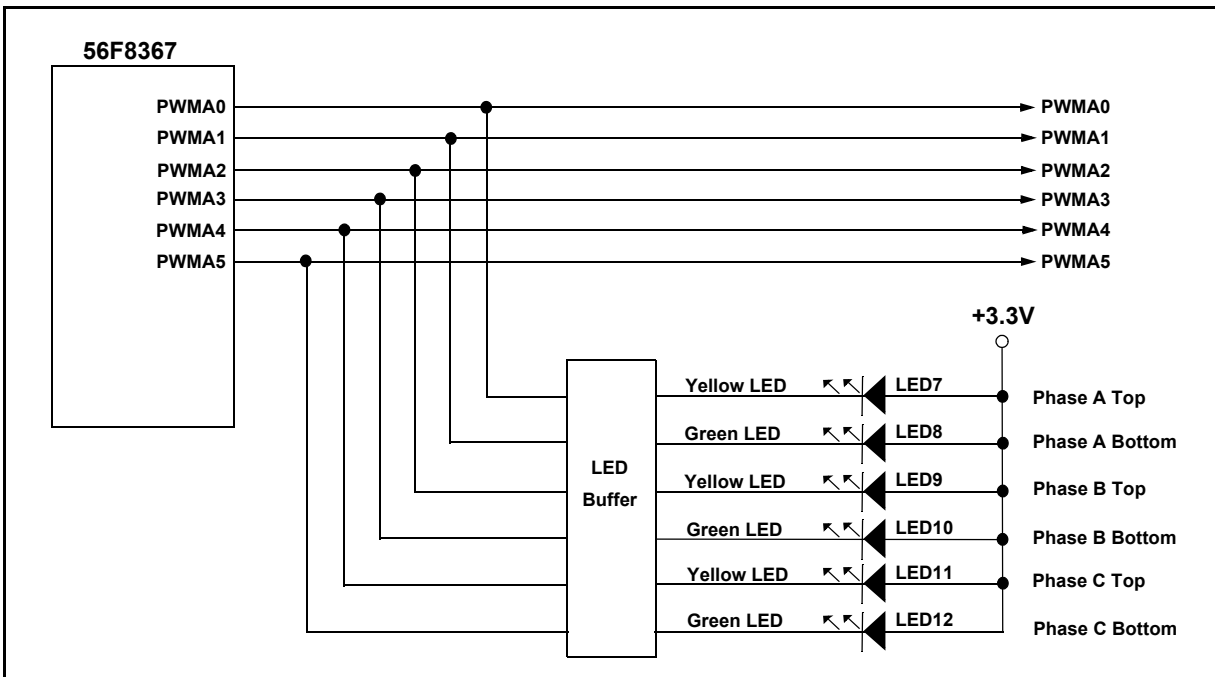

Figure 2-10. PWM Group A Interface and LEDs

2.13 CAN Interfaces

The 56F8367EVM board contains two FlexCAN interfaces. The primary CAN interface uses the CAN1_RX and CAN1_TX pins on the 56F8367. The secondary CAN interface uses the CAN2_RX and CAN2_TX pins on the 56F8367.

2.13.1 FlexCAN #1 Interface

The 56F8367EVM board contains a CAN physical-layer interface chip that is attached to the FlexCAN port's CAN1_RX and CAN1_TX pins on the 56F8367. The EVM board uses a Phillips high-speed, 1.0Mbps, physical layer interface chip, PCA82C250. Due to the +5.0V operating voltage of the CAN interface chip, a pull-up to +5.0V is required to level shift the transmit data output line from the 56F8367. The CANH and CANL signals pass through inductors before attaching to the CAN bus connectors. A primary, J20, and daisy-chain, J21, CAN connector are provided to allow easy daisy-chaining of CAN devices. CAN bus termination of 120 ohms can be provided by adding a jumper to JG13. Refer to [Table 2-14](#) for the CAN connector signals and [Figure 2-12](#) for a connection diagram.

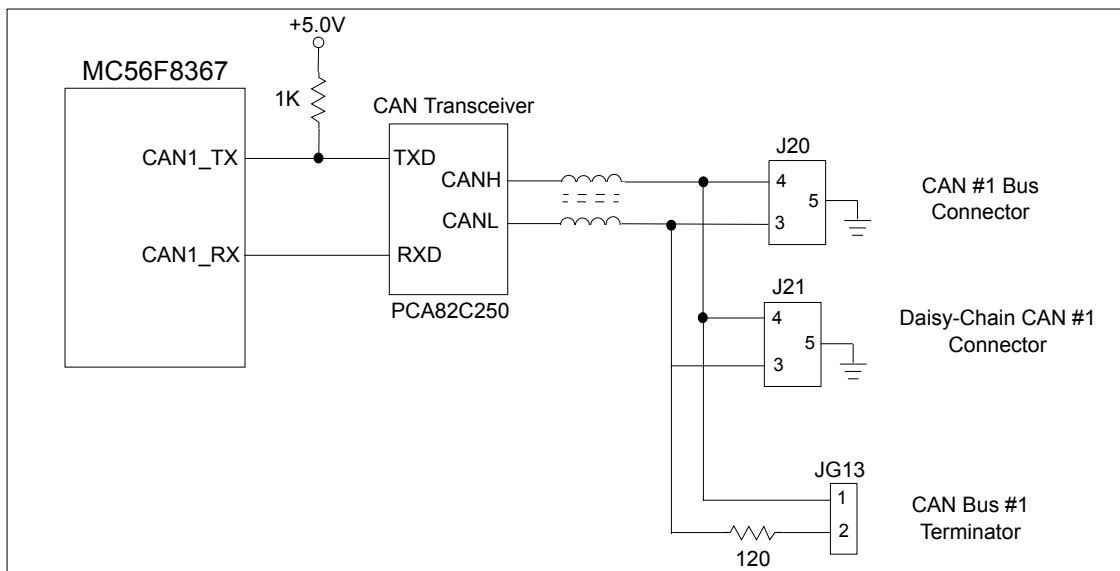

Figure 2-11. CAN #1 Interface

Table 2-13. CAN #1 Header Description

J20 and J21			
Pin #	Signal	Pin #	Signal
1	NC	2	NC
3	CANL	4	CANH
5	GND	6	NC
7	NC	8	NC
9	NC	10	NC

2.13.2 FlexCAN #2 Interface

The 56F8367EVM board contains a second FlexCAN port, the CAN2_RX and CAN2_TX pins on the 56F8367. These signals pass through an isolation jumper, JG14, before going to the CAN physical layer interface. The EVM board uses a Phillips high-speed, 1.0Mbps, physical layer interface chip, PCA82C250. Due to the +5.0V operating voltage of the CAN interface chip, a pull up to +5.0V is required to level shift the transmit data output line from the 56F8367. The CAN2H and CAN2L signals pass through inductors before attaching to the CAN bus connectors. A primary, J22, and daisy-chain, J23, CAN connector are provided to allow easy daisy-chaining of CAN devices. CAN bus termination of 120 ohms can be provided by adding a jumper to JG17. Refer to [Figure 2-12](#) for a connection diagram and to [Table 2-14](#) and [Table 2-15](#) for the CAN connector signals.

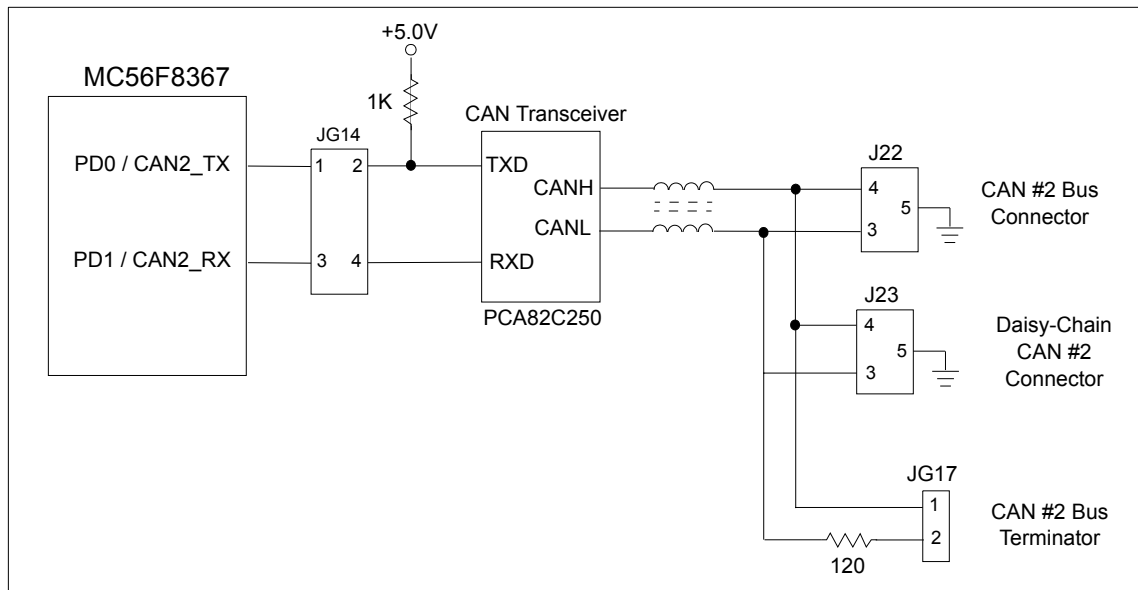
Figure 2-12. CAN #2 Interface
Table 2-14. CAN #2 Header Description

J22 and J23			
Pin #	Signal	Pin #	Signal
1	NC	2	NC
3	CAN2L	4	CAN2H
5	GND	6	NC
7	NC	8	NC
9	NC	10	NC

Table 2-15. CAN #2 Pass-Through Jumper Description

JG14			
Pin #	Signal	Pin #	Signal
1	PD0	2	CAN2_TX
3	PD1	4	CAN2_RX

2.14 Software Feature Jumpers

The 56F8367EVM board contains two software feature jumpers that allow the user to select user-defined software features. Two GPIO port pins, PE4 and PE7, are pulled high or low with 10K ohm resistors on JG15 and JG16. Attaching a jumper between pins 1 and 2 will place a high or 1 on the port pin. Attaching a jumper between pins 2 and 3 will place a low or 0 on the port pin; see [Figure 2-13](#).

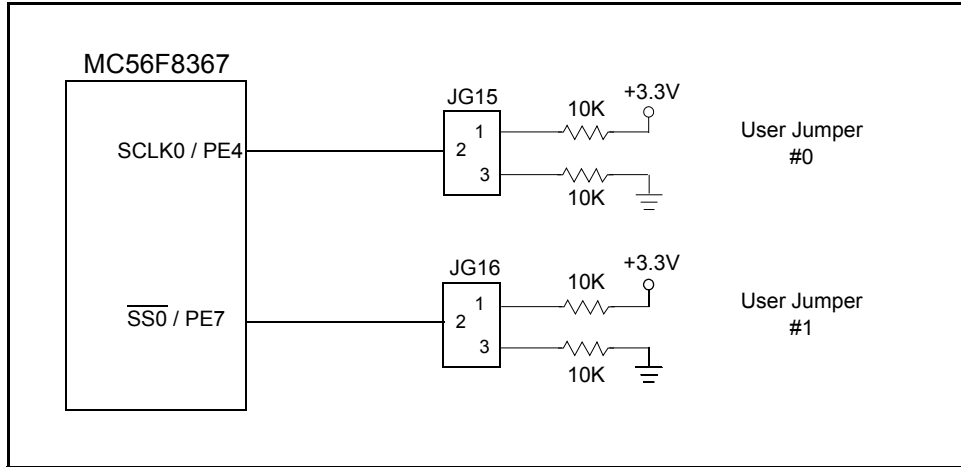

Figure 2-13. Software Feature Jumpers

2.15 Peripheral Expansion Connectors

The EVM board contains a group of peripheral expansion connectors used to gain access to the resources of the 56F8367. The following signal groups have expansion connectors:

- External Memory Address Bus (A0 - A23)
 - General Purpose Port A (bits 0 - 13)
 - General Purpose Port E (bits 2 & 3)
 - General Purpose Port B (bit 0 - 7)
- External Memory Data Bus (D0 - D15)
 - General Purpose Port F (bits 0 - 15)
- External Memory Control
 - General Purpose Port D (bits 0 - 5, 8 & 9)
- Quadrature Decoder #0
 - Quad Timer Channel A
- Quadrature Decoder #1
 - Serial Peripheral Interface Port #1
 - Quad Timer Channel B
 - General Purpose Port C (bits 0 - 3)
- Quad Timer Channel C
 - General Purpose Port E (bits 8 & 9)
- Quad Timer Channel D
 - General Purpose Port E (bits 10 - 13)
- A/D Input Port A
- A/D Input Port B
- Serial Communications Port #0 / General Purpose Port E (bits 0 and 1)
- Serial Communications Port #1 / General Purpose Port D (bits 6 and 7)
- Serial Peripheral Interface Port #0 / General Purpose Port E (bits 4 - 7)
- PWM Port A / General Purpose Port C (bits 8 - 10)
- PWM Port B / General Purpose Port C (bits 0 - 3)
- CAN Port #1
- CAN Port #2

2.15.1 Address Bus Expansion Connector

The address bus expansion connector contains the 56F8367's 24 external memory address signal lines. Address lines A6 and A7 can optionally be used as GPIO Port E lines (bits 2 and 3). Address lines A8 - A15 can optionally be used as GPIO Port A lines (bits 0 - 7). Address lines A0 - A5 can optionally be used as GPIO Port A lines (bits 8 - 13). Address lines A16 - A23 are MPIO signals, which can be configured as A16 - A23 or GPIO Port B bits 0 - 7. Refer to [Table 2-16](#) for the address bus connector information.

Table 2-16. External Memory Address Bus Connector Description

J4			
Pin #	Signal	Pin #	Signal
1	A0 / PA8	2	A1 / PA9
3	A2 / PA10	4	A3 / PA11
5	A4 / PA12	6	A5 / PA13
7	A6 / PE2	8	A7 / PE3
9	A8 / PA0	10	A9 / PA1
11	A10 / PA2	12	A11 / PA3
13	A12 / PA4	14	A13 / PA5
15	A14 / PA6	16	A15 / PA7
17	PB0 / A16	18	PB1 / A17
19	PB2 / A18	20	PB3 / A19
21	PB4 / A20	22	PB5 / A21
23	PB6 / A22	24	PB7 / A23
19	GND	20	+3.3V

2.15.2 Data Bus Expansion Connector

The data bus expansion connector contains the 56F8367's 16 external memory data signal lines. Refer to [Table 2-17](#) for the data bus connector information. Data lines D0 - D15 can also be used as GPIO Port F lines (bits 0 - 15).

Table 2-17. External Memory Address Bus Connector Description

J5			
Pin #	Signal	Pin #	Signal
1	D0 / PF9	2	D1 / PF10
3	D2 / PF11	4	D3 / PF12
5	D4 / PF13	6	D5 / PF14
7	D6 / PF15	8	D7 / PF0
9	D8 / PF1	10	D9 / PF2
11	D10 / PF3	12	D11 / PF4
13	D12 / PF5	14	D13 / PF6
15	D14 / PF7	16	D15 / PF8
17	GND	18	+3.3V

2.15.3 External Memory Control Signal Expansion Connector

The external memory control signal connector contains the 56F8367's external memory control signal lines. CS2 and CS3 are MPIO signals, which can be configured as GPIO Port D lines (bits 0 and 1). Refer to [Table 2-18](#) for the names of these signals.

Table 2-18. External Memory Control Signal Connector Description

J6			
Pin #	Signal	Pin #	Signal
1	\overline{RD}	2	\overline{IRQA}
3	\overline{WR}	4	\overline{IRQB}
5	$\overline{PS} / \overline{CS0}$	6	$\overline{DS} / \overline{CS1}$
7	PD0 / $\overline{CS2}$ / CAN2_TX	8	PD1 / $\overline{CS3}$ / CAN2_RX
	PD2 / $\overline{CS4}$		PD3 / $\overline{CS5}$
	PD4 / $\overline{CS6}$		PD5 / $\overline{CS7}$
9	CLKO	10	\overline{RESET}
11	GND	12	\overline{RSTO}

2.15.4 Encoder #0 / Quad Timer Channel A Expansion Connector

The Encoder #0 / Quad Timer Channel A port is an MPIO port attached to the Timer A expansion connector. This port can be configured as a Quadrature Decoder interface port or as a Quad Timer port. Refer to [Table 2-19](#) for the signals attached to the connector.

Table 2-19. Timer A Signal Connector Description

J15			
Pin #	Signal	Pin #	Signal
1	PHASEA0 / TA0	2	PHASEB0 / TA1
3	INDEX0 / TA2	4	HOME0 / TA3
5	GND	6	+3.3V

2.15.5 Encoder #1 / SPI #1 Expansion Connector

The Encoder #1 / SPI #1 port is an MPIO port attached to the SPI #1 expansion connector. This port can be configured as a Quadrature Decoder interface port, a Serial Peripheral Interface, Quad Timer port or General Purpose I/O port. Refer to [Table 2-20](#) for the signals attached to the connector.

Table 2-20. SPI #1 Signal Connector Description

J12			
Pin #	Signal	Pin #	Signal
1	PHASEB1 / MOSI1 / TB1 / PC1	2	INDEX1 / MISO1 / TB2 / PC2
3	PHASEA1 / SCLK1 / TB0 / PC0	4	HOME1 / $\overline{SS1}$ / TB3 / PC3
5	GND	6	+3.3V

2.15.6 Timer Channel C Expansion Connector

The Timer Channel C port is a Quad Timer port attached to the Timer C expansion connector. This port can be configured as a Quad Timer port or a General Purpose I/O port. Refer to [Table 2-21](#) for the signals attached to the connector.

Table 2-21. Timer Channel C Connector Description

J16			
Pin #	Signal	Pin #	Signal
1	TC0 / PE8	2	TC1 / PE9
3	GND	4	+3.3V

2.15.7 Timer Channel D Expansion Connector

The Timer Channel D port is a Quad Timer attached to the Timer D expansion connector. This port can be configured as a Quad Timer port or a General Purpose I/O port. Refer to [Table 2-22](#) for the signals attached to the connector.

Table 2-22. Timer Channel D Connector Description

J17			
Pin #	Signal	Pin #	Signal
1	TD0 / PE10	2	TD1 / PE11
3	TD2 / PE12	4	TD3 / PE13
3	GND	4	+3.3V

2.15.8 A/D Port A Expansion Connector

The eight-channel Analog-to-Digital conversion Port A is attached to this connector. Refer to [Table 2-23](#) for connection information. There is a Resistor/Connector (R/C) network on each of the Analog Port A input signals; see [Figure 2-14](#).

Table 2-23. A/D Port A Connector Description

J9			
Pin #	Signal	Pin #	Signal
1	AN0	2	AN1
3	AN2	4	AN3
5	AN4	6	AN5
7	AN6	8	AN7
9	GND A	10	+V _{REFH}

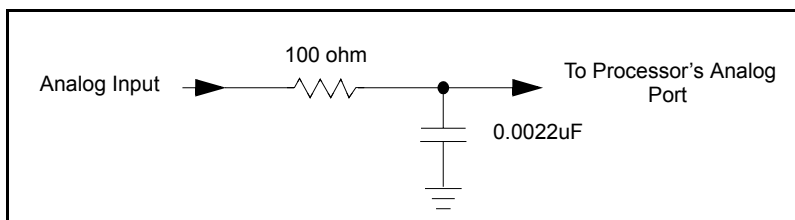

Figure 2-14. Typical Analog Input RC Filter

2.15.9 A/D Port B Expansion Connector

The eight-channel Analog-to-Digital conversion Port B is attached to this connector. Refer to [Table 2-24](#) for connection information. There is an R/C network on each of the Analog Port B input signals; see [Figure 2-14](#).

Table 2-24. A/D Port B Connector Description

J10			
Pin #	Signal	Pin #	Signal
1	AN8	2	AN9
3	AN10	4	AN11
5	AN12	6	AN13
7	AN14	8	AN15
9	GND	10	+V _{REFH}

2.15.10 Serial Communications Port #0 Expansion Connector

The Serial Communications Port #0 is an MPIO port attached to the SCI #0 expansion connector. This port can be configured as a Serial Communications Interface or as a General Purpose I/O port. Refer to [Table 2-25](#) for connection information.

Table 2-25. SCI #0 Connector Description

J13			
Pin #	Signal	Pin #	Signal
1	TXD0 / PE0	2	RXD0 / PE1
3	GND	4	+3.3V
5	GND	6	+5.0V

2.15.11 Serial Communications Port #1 Expansion Connector

The Serial Communications Port #1 is an MPIO port attached to the SCI #1 expansion connector. This port can be configured as a Serial Communications Interface or as a General Purpose I/O port. Refer to [Table 2-26](#) for connection information.

Table 2-26. SCI #1 Connector Description

J14			
Pin #	Signal	Pin #	Signal
1	TXD1 / PD6	2	RXD1 / PD7
3	GND	4	+3.3V
5	GND	6	+5.0V

2.15.12 Serial Peripheral Interface #0 Expansion Connector

The Serial Peripheral Interface #0 is an MPIO port attached to this connector. This port can be configured as a Serial Peripheral Interface or as a General Purpose I/O port. Refer to [Table 2-27](#) for the connection information.

Table 2-27. SPI #0 Connector Description

J11			
Pin #	Signal	Pin #	Signal
1	MOSI0 / PE5	2	MISO0 / PE6
3	SCLK0 / PE4	4	$\overline{SS0}$ / PE7
5	GND	6	+3.3V

2.15.13 FlexCAN #1 Expansion Connector

The FlexCAN Port #1 is attached to this connector. Refer to [Table 2-28](#) for connection information.

Table 2-28. CAN #1 Connector Description

J18			
Pin #	Signal	Pin #	Signal
1	CAN1_TX	2	GND
3	CAN1_RX	4	GND

2.15.14 FlexCAN #2 Expansion Connector

The FlexCAN Port #2 is attached to this connector. Refer to [Table 2-29](#) for connection information.

Table 2-29. CAN #2 Connector Description

J19			
Pin #	Signal	Pin #	Signal
1	CAN2_TX	2	GND
3	CAN2_RX	4	GND

2.15.15 PWM Port A Expansion Connector

The PWM Port A is attached to this connector. Refer to [Table 2-30](#) for connection information.

Table 2-30. PWM Port A Connector Description

J7			
Pin #	Signal	Pin #	Signal
1	PWMA0	2	PWMA1
3	PWMA2	4	PWMA3
5	PWMA4	6	PWMA5
7	FAULTA0	8	FAULTA1
9	FAULTA2	10	FAULTA3
11	ISA0 / PC8	12	ISA1 / PC9
13	ISA2 / PC10	14	GND

2.15.16 PWM Port B Expansion Connector

The PWM Port B is attached to this connector. Refer to [Table 2-31](#) for connection information.

Table 2-31. PWM Port B Connector Description

J8			
Pin #	Signal	Pin #	Signal
1	PWMB0	2	PWMB1
3	PWMB2	4	PWMB3
5	PWMB4	6	PWMB5
7	FAULTB0	8	FAULTB1
9	FAULTB2	10	FAULTB3
11	ISB0 / PD10	12	ISB1 / PD11
13	ISB2 / PD12	14	GND

2.16 Test Points

The 56F8367EVM board has a total of seven test points:

- Analog Ground (AGND)
- Three Digital Grounds (GND)
- +3.3V
- +3.3VA
- +5.0V

Appendix A

56F8367EVM Schematics

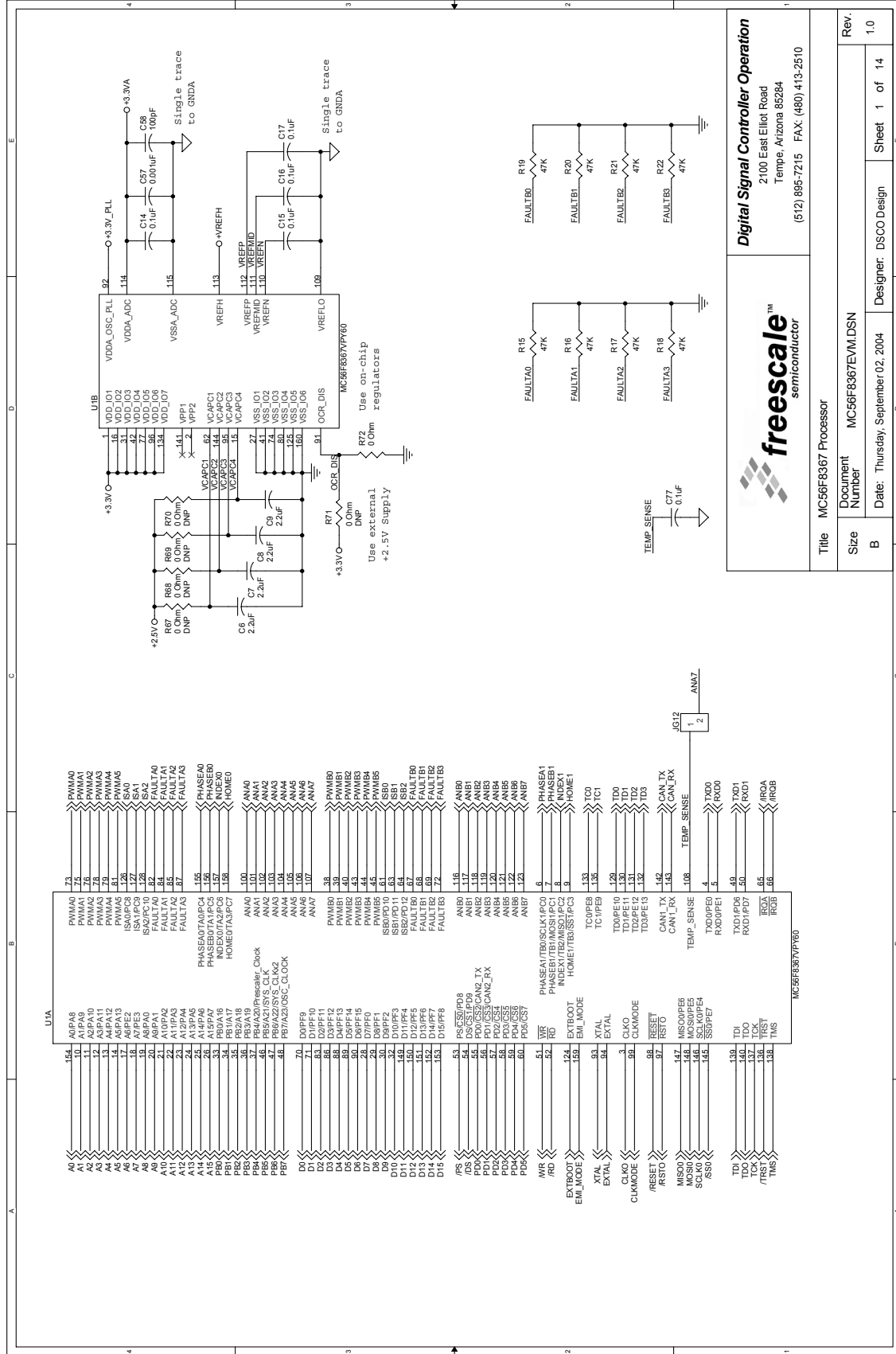

Figure A-1. 56F8367 Processor

freescale™
semiconductor

Digital Signal Controller Operation
2100 East Elliot Road
Tempe, Arizona 85284
(512) 885-7215 FAX: (480) 413-2510

Title: MC56F8367 Processor
Document Number: MC56F8367EVM.DSN
Size: B
Date: Thursday, September 02, 2004
Designer: DSCO Design
Sheet: 1 of 14
Rev. 1.0

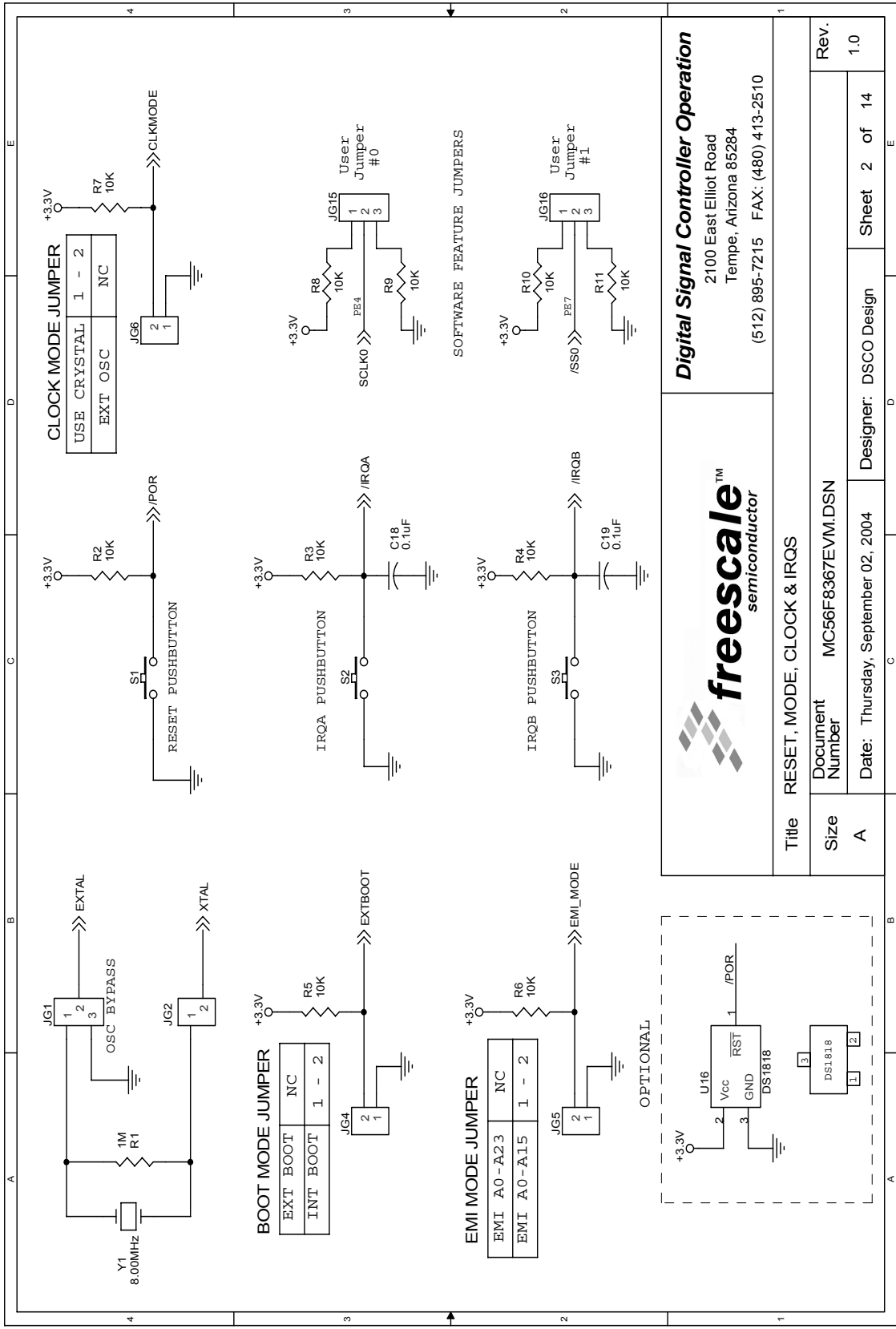
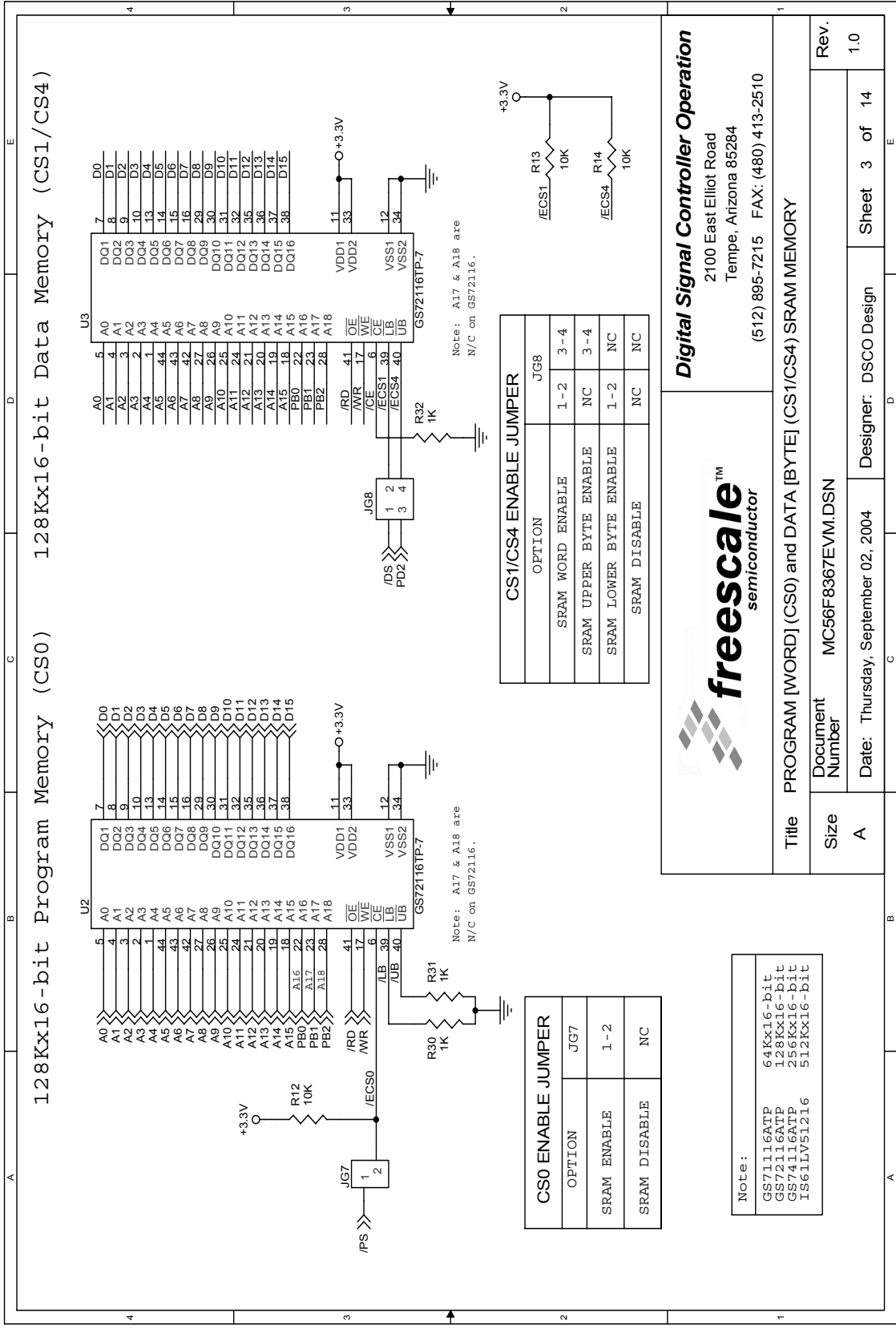

Figure A-2. Reset, Mode, Clock & IRQs



freescale™
semiconductor

Digital Signal Controller Operation
2100 East Elliot Road
Tempe, Arizona 85284
(512) 895-7215 FAX: (480) 413-2510

Figure A-3. Program [Word] (CS0) & Data [Byte] (CS1/CS4) SRAM Memory

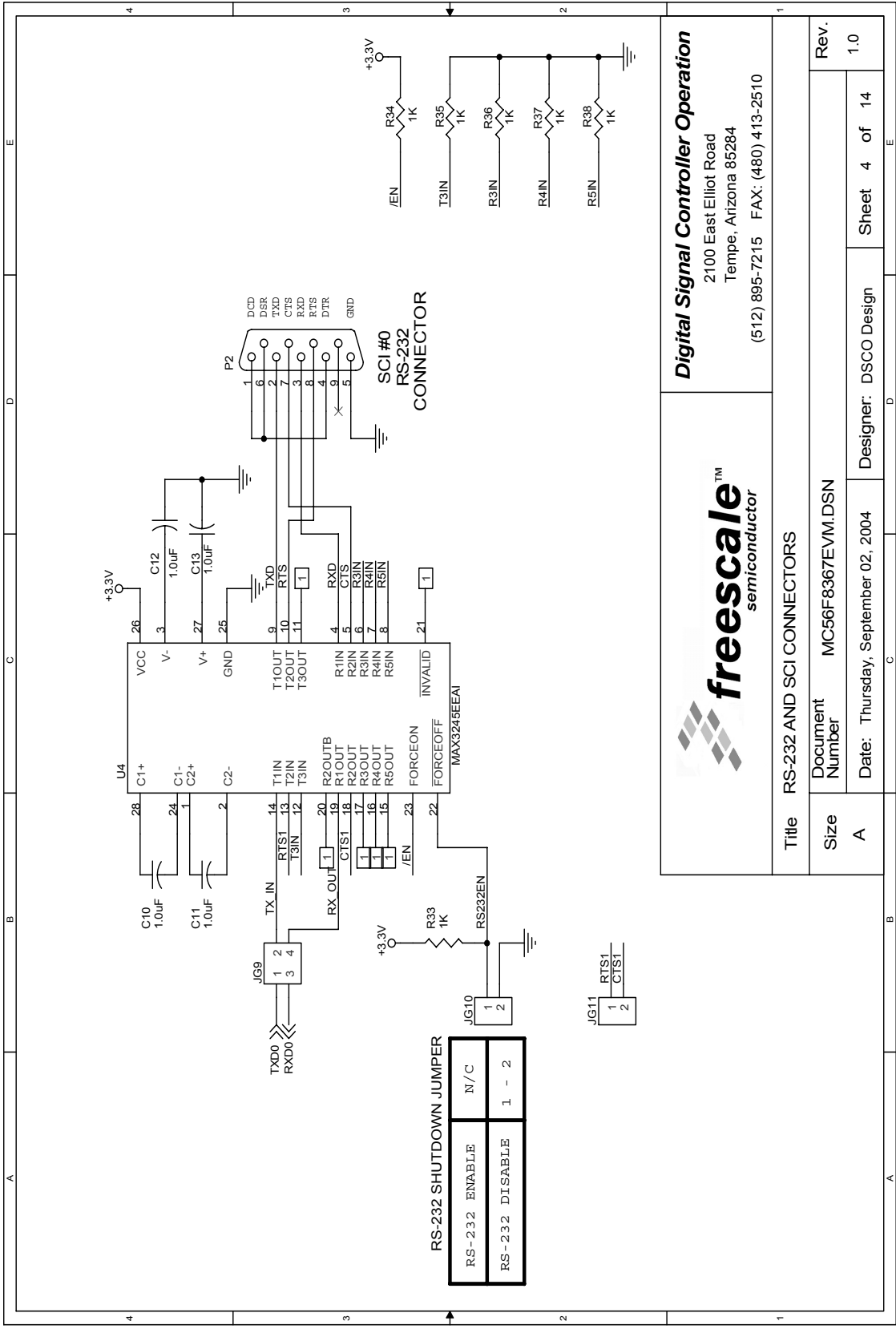



Digital Signal Controller Operation
 2100 East Elliot Road
 Tempe, Arizona 85284
 (512) 895-7215 FAX: (480) 413-2510

Title RS-232 AND SCI CONNECTORS	
Document Number MC56F8367EVM.DSN	Rev. 1.0
Date: Thursday, September 02, 2004	Designer: DSCO Design
Sheet 4 of 14	

Figure A-4. RS-232 and SCI Connectors

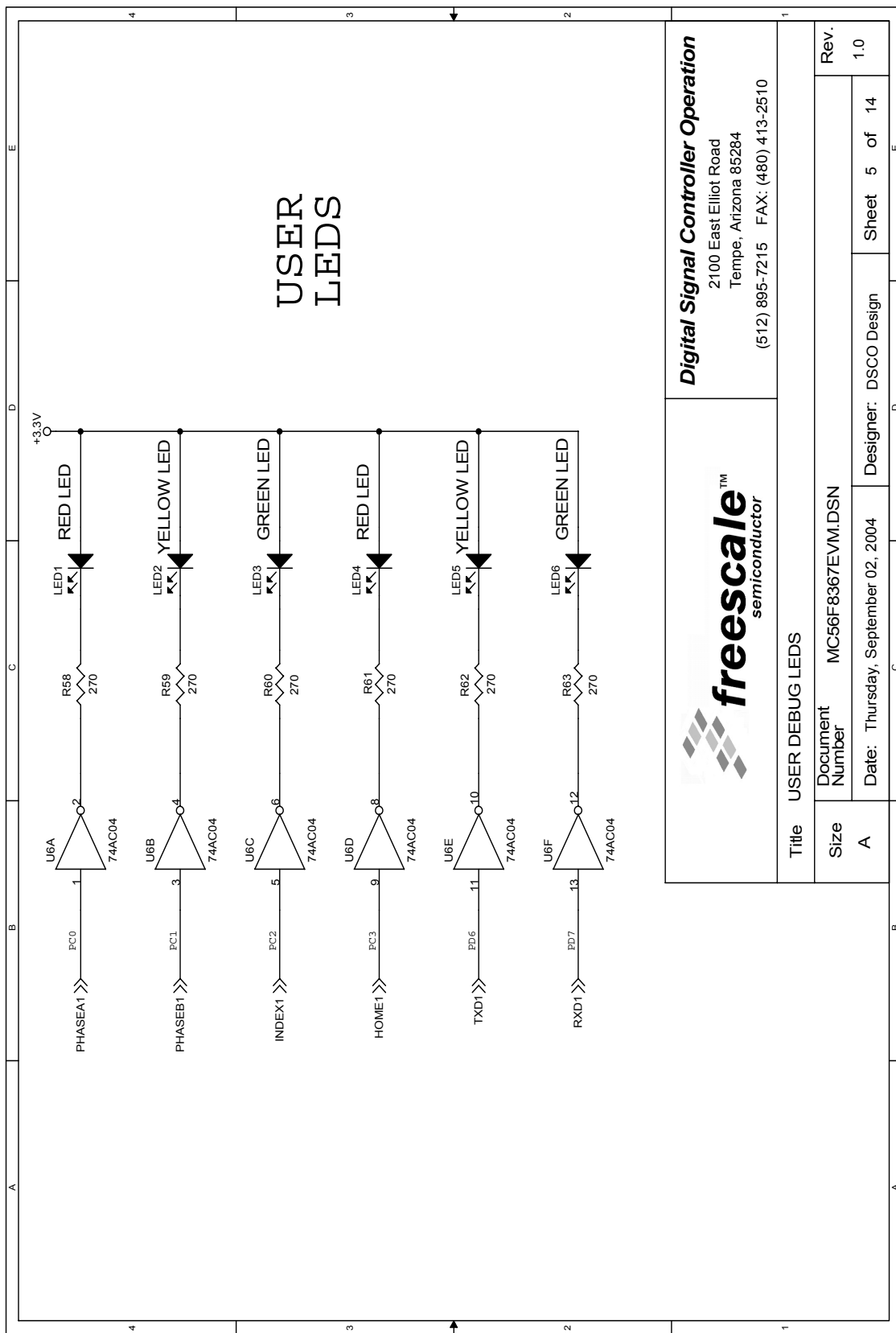

		Digital Signal Controller Operation 2100 East Elliot Road Tempe, Arizona 85284 (512) 895-7215 FAX: (480) 413-2510	
Title USER DEBUG LEDES		Rev. 1.0	
Size A	Document Number MC56F8367EVM.DSN	Date: Thursday, September 02, 2004	Designer: DSCO Design
		Sheet 5 of 14	

Figure A-5. User Debug LEDs

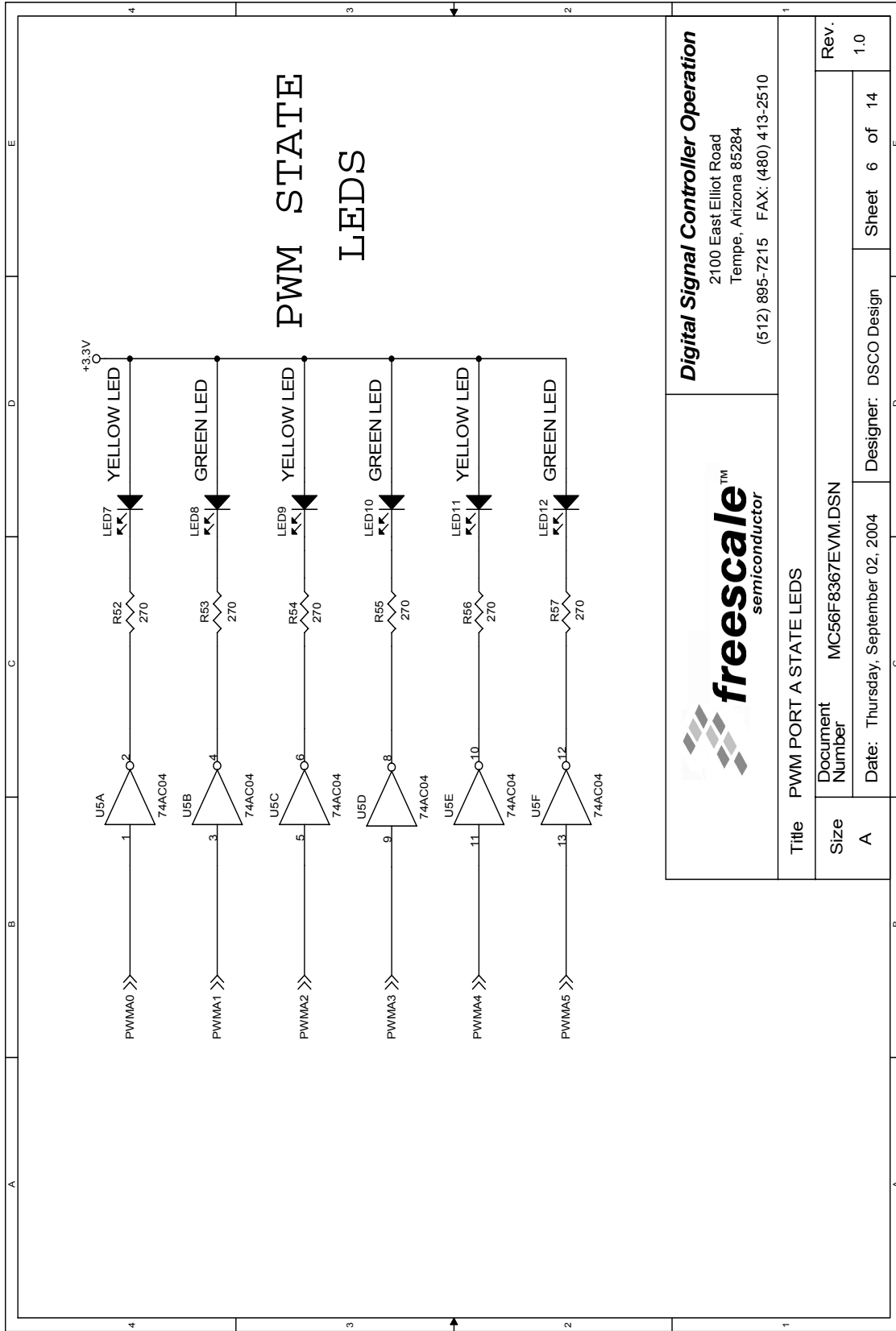
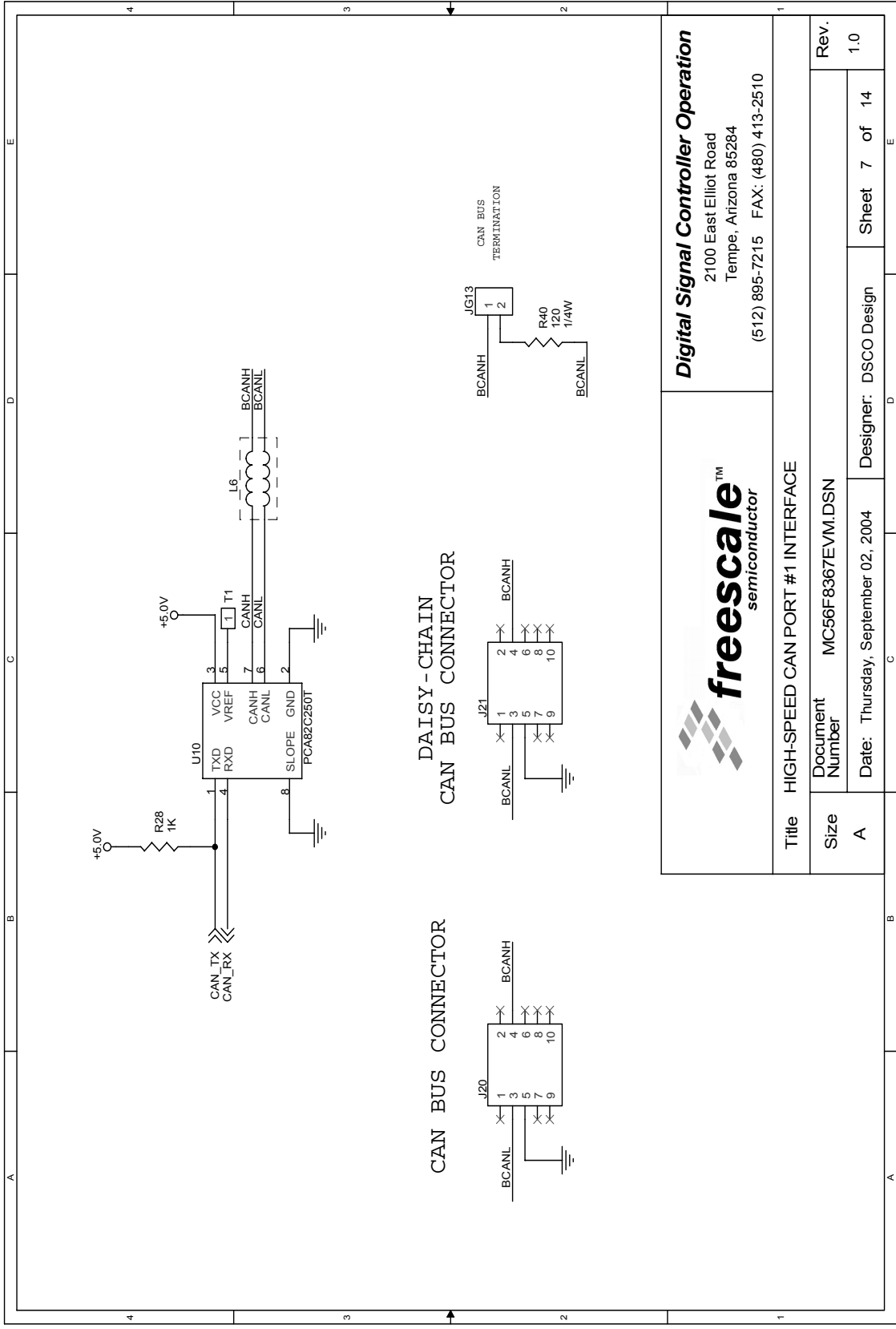

Figure A-6. PWM Port A State LEDs



freescale™
semiconductor

Digital Signal Controller Operation
2100 East Elliot Road
Tempe, Arizona 85284
(512) 895-7215 FAX: (480) 413-2510

Title		HIGH-SPEED CAN PORT #1 INTERFACE	
Size	Document Number	MC56F8367EVM.DSN	
A	Date:	Thursday, September 02, 2004	Designer: DSCO Design
Rev.		Sheet 7 of 14	1.0

Figure A-7. High-Speed CAN Port #1 Interface

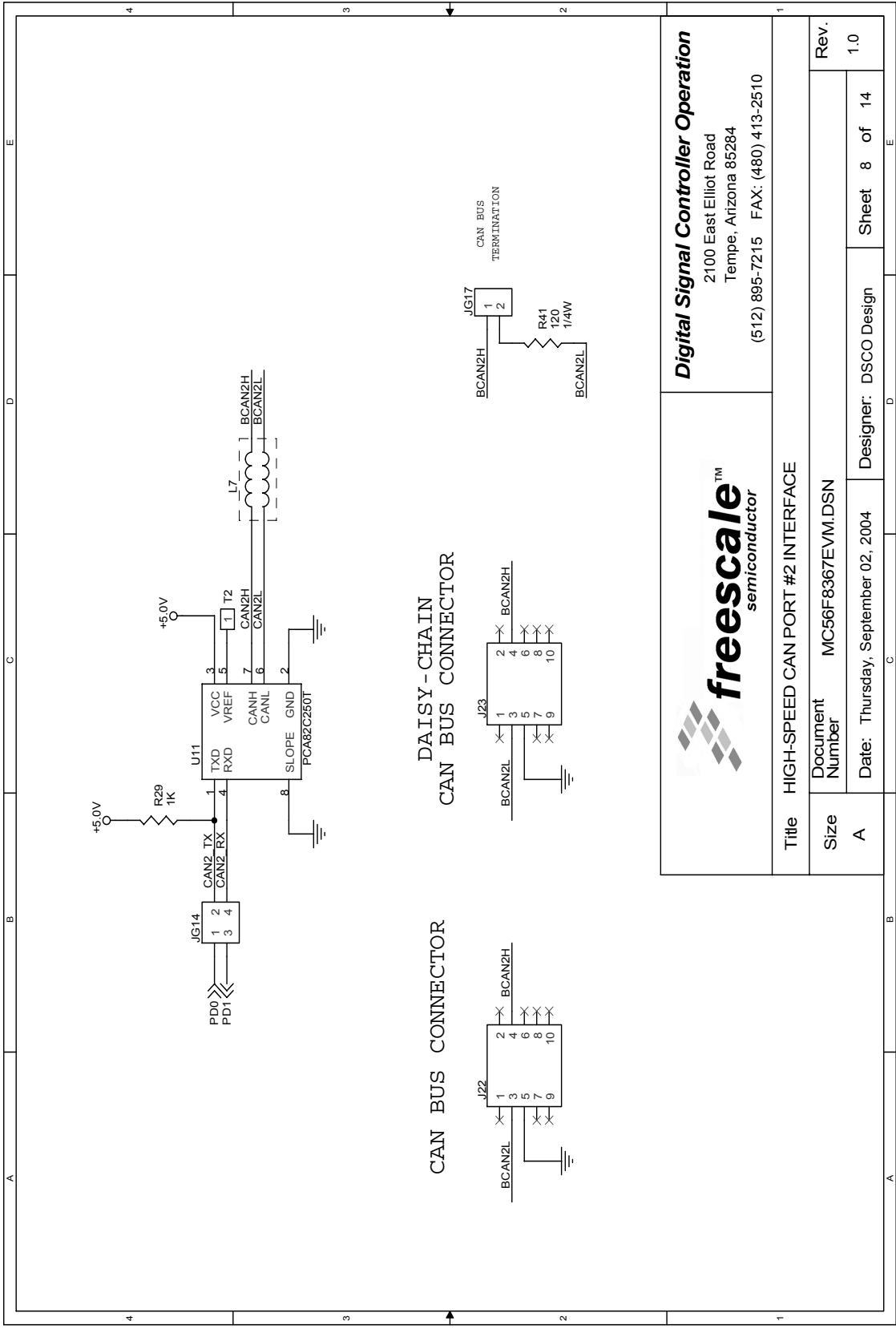

Digital Signal Controller Operation
 2100 East Elliot Road
 Tempe, Arizona 85284
 (512) 895-7215 FAX: (480) 413-2510

Title: HIGH-SPEED CAN PORT #2 INTERFACE	
Document Number: MC56F8367EVM.DSN	Rev.: 1.0
Date: Thursday, September 02, 2004	Designer: DSCO Design
Sheet 8 of 14	

Figure A-8. High-Speed CAN Port #2 Interface

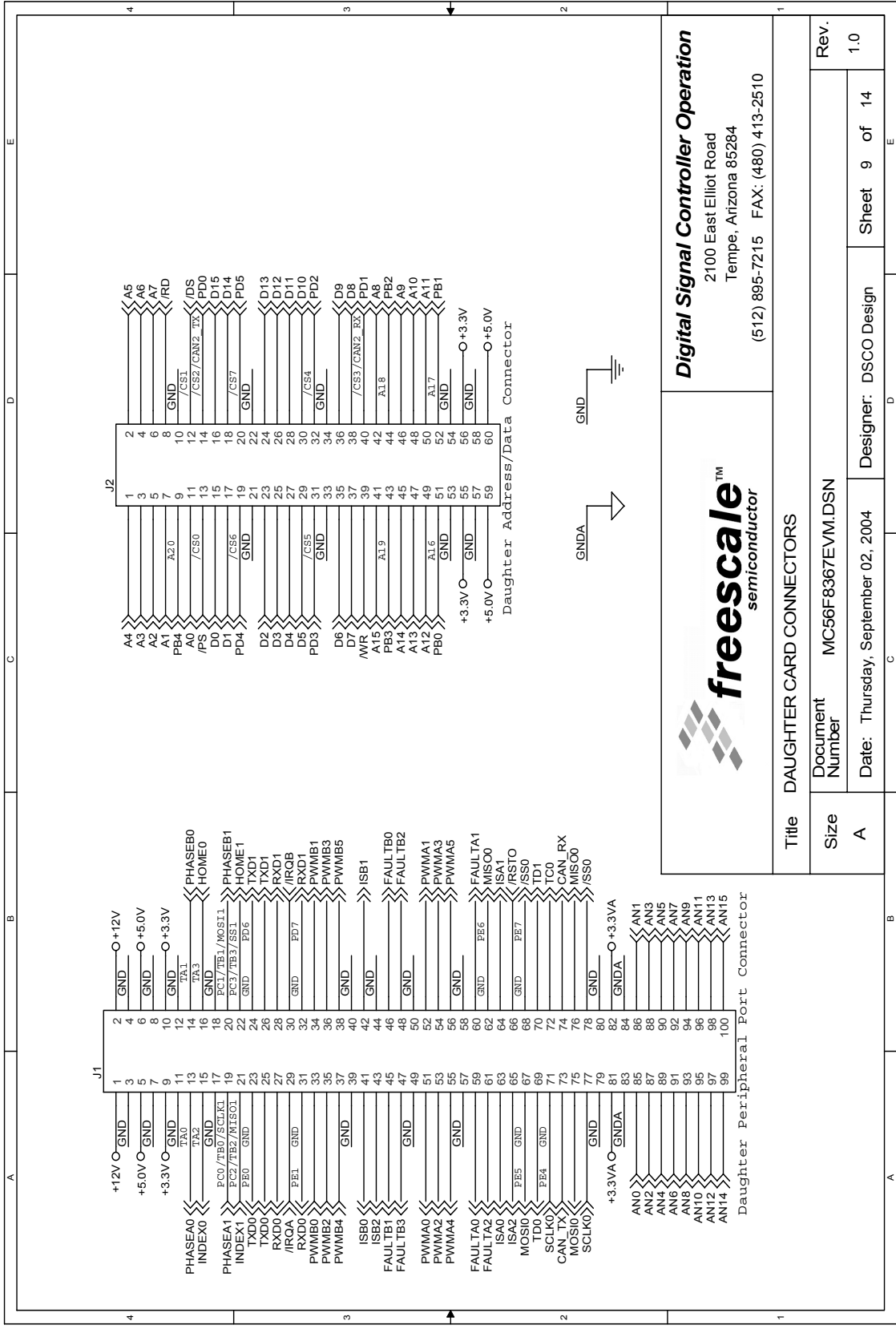

MC56F8367EVM User Manual, Rev. 2

Figure A-9. Daughter Card Connectors

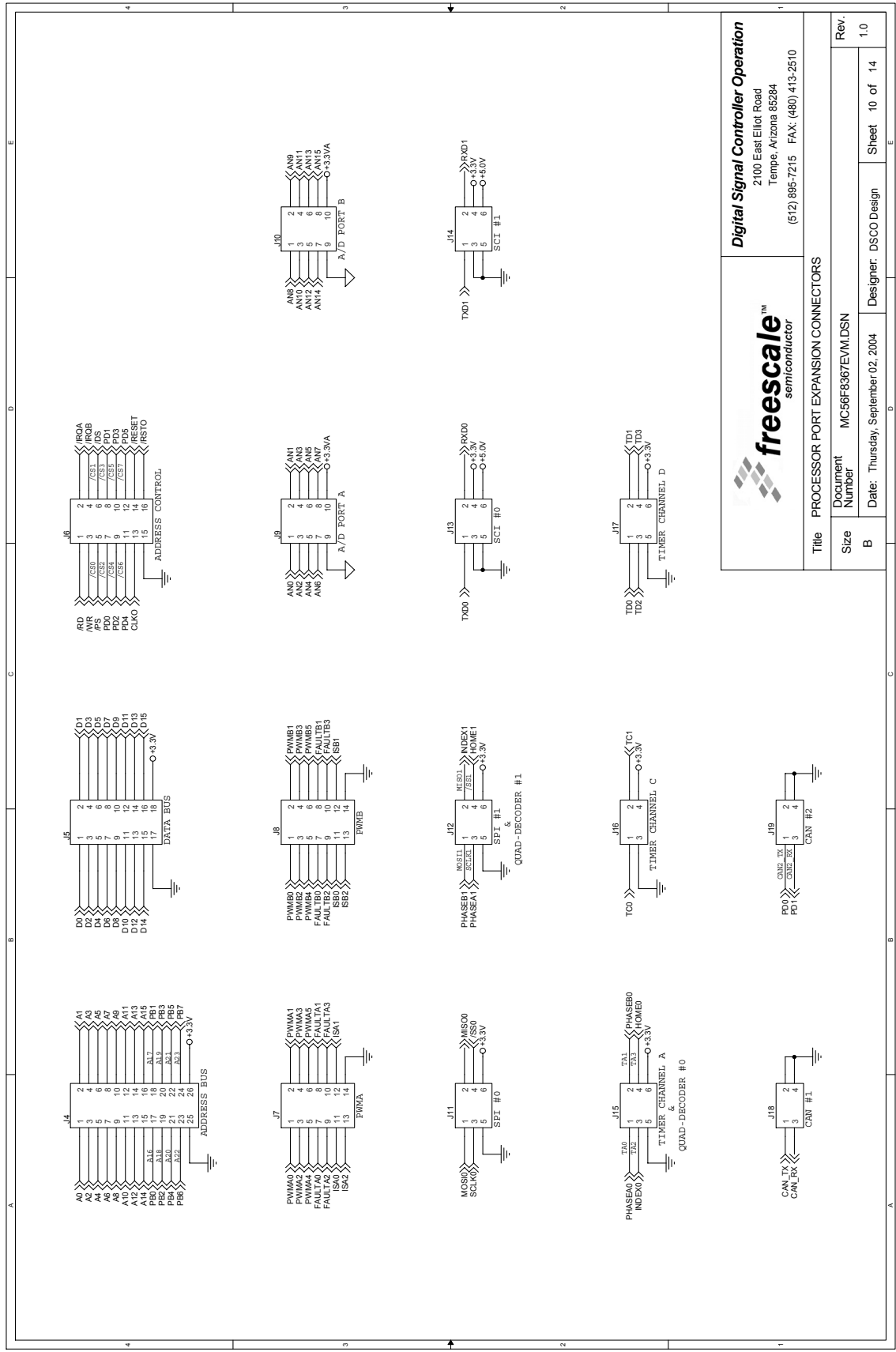

Digital Signal Controller Operation
 2100 East Elliot Road
 Tempe, Arizona 85284
 (612) 895-7215 FAX: (480) 413-2510

Title PROCESSOR PORT EXPANSION CONNECTORS

Document Number	MC56F8367EVM.DSN	Rev.	1.0
Date	Thursday, September 02, 2004	Designer	DSCO Design
Sheet	10 of 14		

56F8367EVM Schematics, Rev. 2

Figure A-10. Processor Port Expansion Connectors

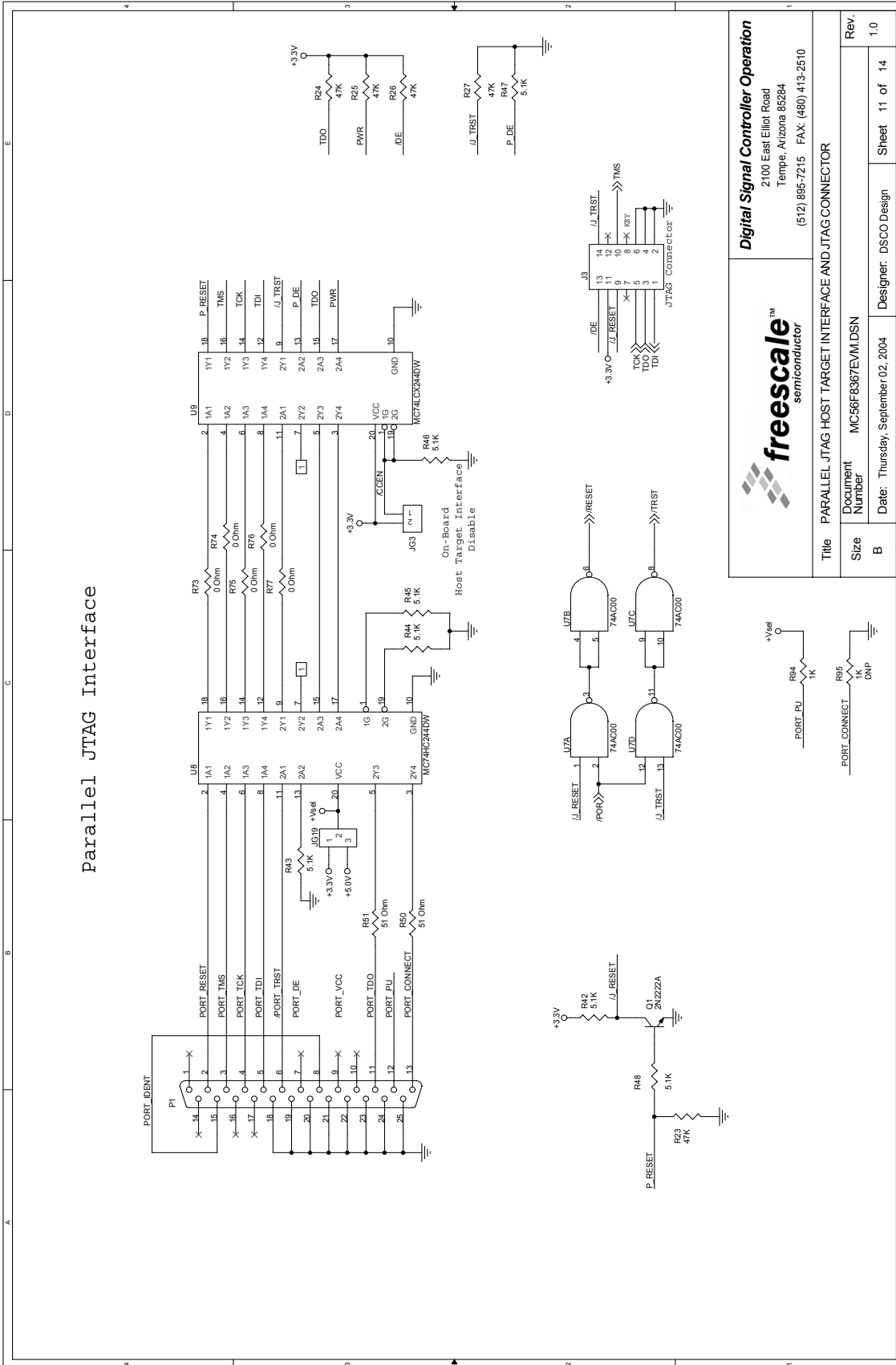
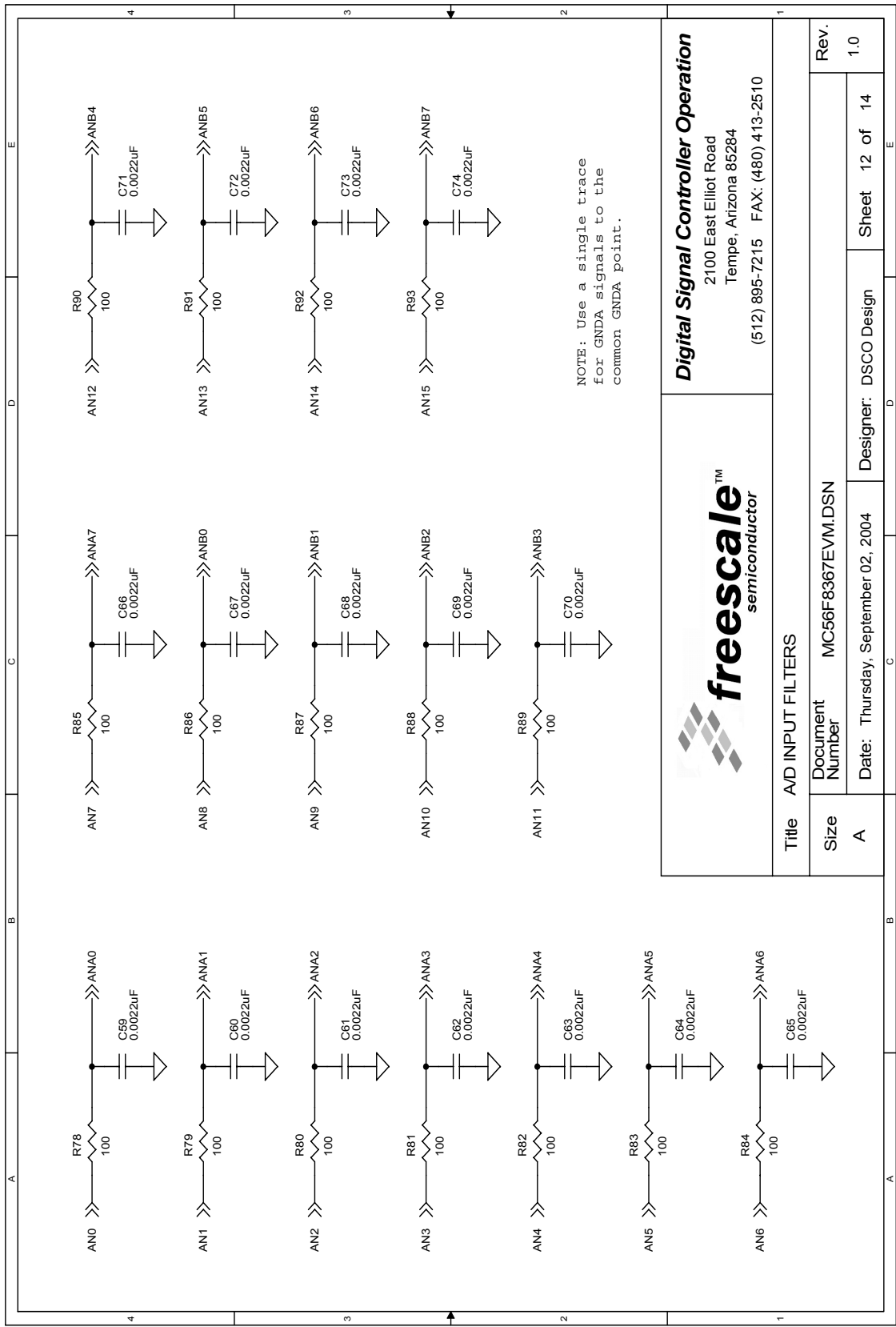

Figure A-11. Parallel JTAG Host Target Interface and JTAG Connector



		Digital Signal Controller Operation 2100 East Elliot Road Tempe, Arizona 85284 (512) 895-7215 FAX: (480) 413-2510	
		Title: A/D INPUT FILTERS	Rev. 1.0
Document Number: MC56F8367EVM.DSN	Date: Thursday, September 02, 2004	Designer: DSCO Design	Sheet 12 of 14

Figure A-12. A/D Input Filters

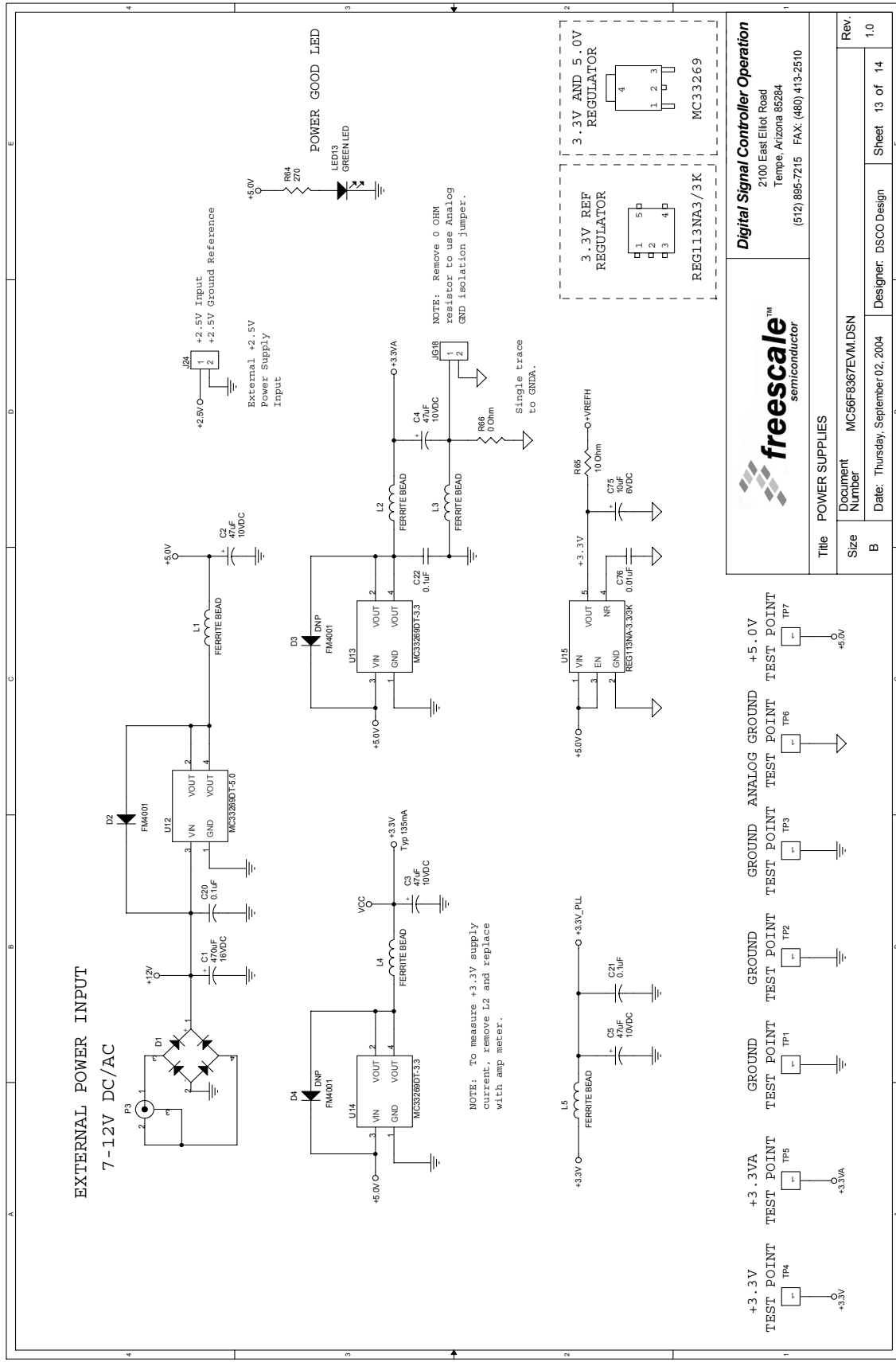
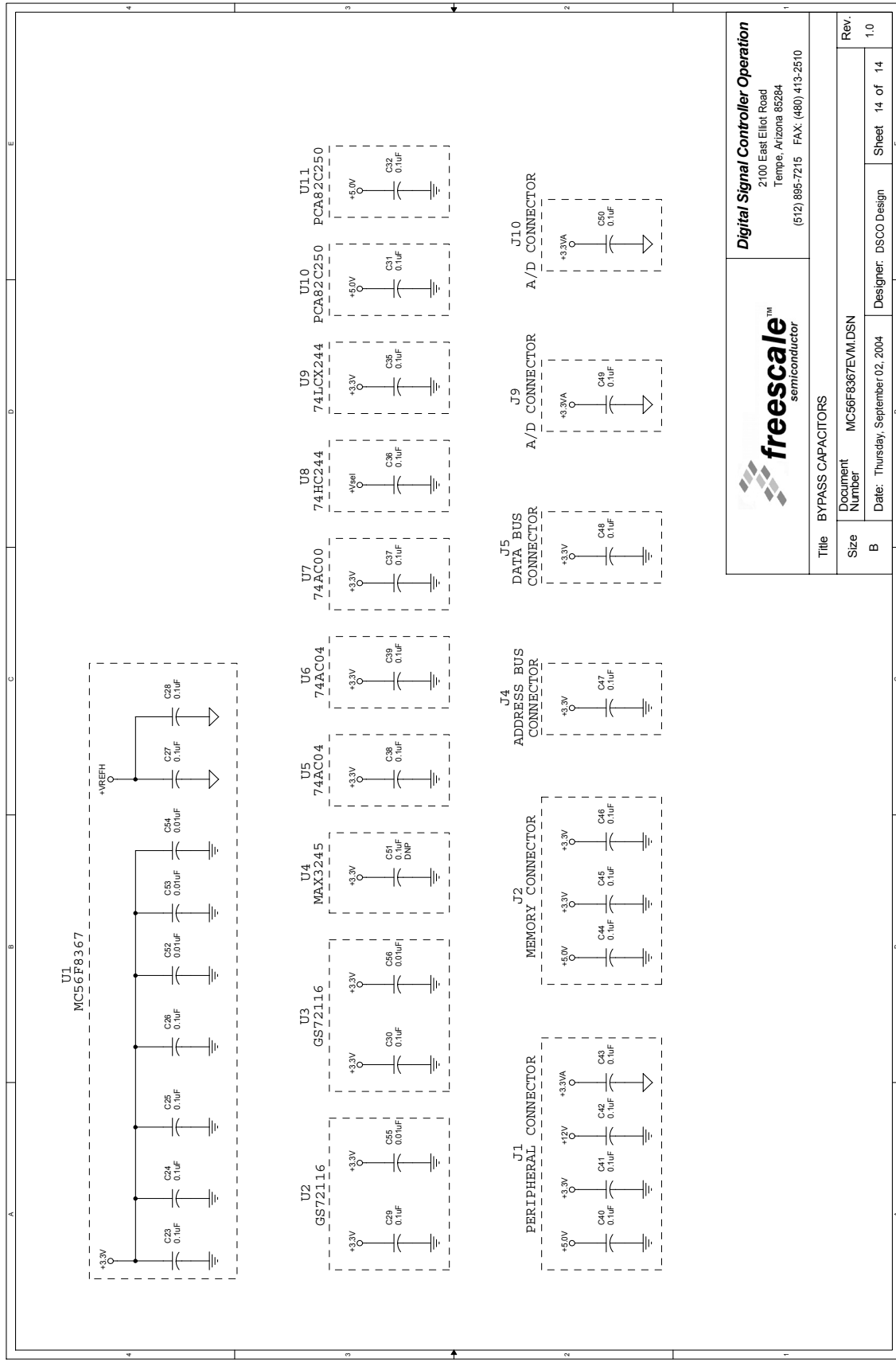

Figure A-13. Power Supplies



freescale™
semiconductor

Digital Signal Controller Operation
2100 East Elliot Road
Tempe, Arizona 85284
(612) 895-7215 FAX: (480) 413-2510

Title		BYPASS CAPACITORS	
Document Number	MC56F8367EVM.DSN	Designer	DSCO Design
Size	B	Date	Thursday, September 02, 2004
Rev.	1.0	Sheet	14 of 14

Figure A-14. Bypass Capacitors

Appendix B

56F8367EVM Bill of Material

Qty	Description	Ref. Designators	Vendor Part #
Integrated Circuits			
1	MC56F8367	U1	Freescale, MC56F8367VPY60
2	128K x 16-Bit SRAM	U2, U3	GSI, GS72116ATP-8
1	RS-232 Transceiver	U4	Maxim, MAX3245EEAI
2	74AC04	U5, U6	ON Semiconductor, MC74AC04AD
1	74AC00	U7	Fairchild, 74AC00SC
1	74HC244	U8	ON Semiconductor, MC74LHC44AADW
1	74LCX244	U9	ON Semiconductor, MC74LCX244ADW
2	CAN Transceiver	U10, U11	Philips Semiconductor, PCA82C250T
1	+5.0V Voltage Regulator	U12	ON Semiconductor, MC33269DT-5
2	+3.3V Voltage Regulator	U13, U14	ON Semiconductor, MC33269DT-3.3
1	+3.3V Voltage Regulator	U15	Burr-Brown, REG113NA-3.3
0	Power-On Reset	U16 (Optional)	Dallas Semiconductor, DS1818
Resistors			
1	1M Ω	R1	SMEC, RC73L2A105OHMJT
13	10K Ω	R2 - R14	SMEC, RC73L2A103OHMJT
13	47K Ω	R15 - R27	SMEC, RC73L2A473OHMJT
12	1K Ω	R28 - R38, R94	SMEC, RC73L2A103OHMJT
0	1K Ω	R95 (Optional)	SMEC, RC73L2A103OHMJT
2	120 Ω , 1/4W	R40, R41	YAGEO, CFR 120QBK

Qty	Description	Ref. Designators	Vendor Part #
Resistors (Continued)			
7	5.1K Ω	R42 - R48	SMEC, RC73L2A512OHMJT
2	51 Ω	R50, R51	SMEC, RC73L2A51OHMJT
13	270 Ω	R52 - R64	SMEC, RC73L2A271OHMJT
1	10 Ω	R65	SMEC, RC73L2A100OHMJT
7	0 Ω	R66, R72 - R77	SMEC, RC73JP2A
0	0 Ω	R67 - R71 (Optional)	SMEC, RC73JP2A
16	100 Ω	R78 - R93	SMEC, RC73L2A101OHMJT
Inductors			
5	1.0mH FERRITE BEAD	L1 - L5	Panasonic, EXC-ELSA35V
2	CAN Bus Filter	L6, L7	EPCOS, B82790-S0513-N201
LEDs			
2	Red LED	LED1, LED4	Hewlett-Packard, HSMS-C650
5	Yellow LED	LED2, LED5, LED7, LED9, LED11	Hewlett-Packard, HSMY-C650
6	Green LED	LED3, LED6, LED8, LED10, LED12, LED13	Hewlett-Packard, HSMG-C650
Diode			
1	+50V 1A BRIDGE RECT	D1	DIODES, DF02S
1	S2B-FM401	D2	Vishay, DL4001DICT
0	S2B-FM401	D3, D4 (Optional)	Vishay, DL4001DICT
Capacitors			
1	470 μ F, +16V DC	C1	ELMA, RV-16V471MH10R
4	47 μ F, +16V DC	C2 - C5	ELMA, RV2-16V470M-R
4	2.2 μ F, +25V DC (Low ESR)	C6 - C9	TAIYO YUDEN, CELMK212BJ225MG-T
4	1.0 μ F, +25V DC	C10 - C13	SMEC, MCCE105K3NR-T1
37	0.1 μ F	C14 - C32, C35 - C51, C77	SMEC, MCCE104K2NR-T1
6	0.01 μ F	C52 - C56, C76	SMEC, MCCE103K2NR-T1

Qty	Description	Ref. Designators	Vendor Part #
Capacitors (Continued)			
1	0.001 μ F	C57	SMEC, MCCE102K2NR-T1
1	100pF	C58	SMEC, MCCE101K2NR-T1
16	0.0022 μ F	C59 - C74	SMEC, MCCE222K2NR-T1
1	10 μ F, +10V DC	C75	KEMET, T494B106M010AS
Jumpers			
4	3 \times 1 Bergstick	JG1, JG15, JG16, JG19	SAMTEC, TSW-103-07-S-S
12	1 \times 2 Bergstick	JG2 - JG7, JG10 - JG13, JG17, JG18	SAMTEC, TSW-102-07-S-S
3	2 \times 2 Bergstick	JG8, JG9, JG14	SAMTEC, TSW-102-07-S-D
Test Points			
3	GND Test Point	TP1, TP2, TP3	KEYSTONE, 5001, BLACK
1	+3.3V Test Point	TP4	KEYSTONE, 5000, RED
1	+3.3V A Test Point	TP5	KEYSTONE, 5004, YELLOW
1	GND A Test Point	TP6	KEYSTONE, 5002, WHITE
1	+5.0V Test Point	TP7	KEYSTONE, 5003, ORANGE
Crystals			
1	8.00MHz Crystal	Y1	CTS, ATS08ASM-T
Connectors			
1	DB25M Connector	P1	AMPHENOL, 617-C025P-AJ121
1	DE9S Connector	P2	AMPHENOL, 617-C009S-AJ120
1	2.1mm coax Power Connector	P3	Switchcraft, RAPC-722
1	Peripheral Daughter Card Connector	J1	HRS, FX6-100P-0.8SV2
1	Memory Bus Daughter Card Connector	J2	HRS, FX6-60P-0.8SV2
1	7 x 2 JTAG Header	J3	SAMTEC, TSW-106-07-S-D
1	13 x 2 Header	J4	SAMTEC, TSW-106-13-S-D

Qty	Description	Ref. Designators	Vendor Part #
Connectors (Continued)			
1	9 x 2 Header	J5	SAMTEC, TSW-106-09-S-D
1	8 x 2 Header	J6	SAMTEC, TSW-106-08-S-D
2	7 x 2 Header	J7, J8	SAMTEC, TSW-106-07-S-D
6	5 x 2 Header	J9, J10, J20 - J23	SAMTEC, TSW-106-05-S-D
6	3 x 2 Header	J11 - J15, J17	SAMTEC, TSW-106-03-S-D
3	2 x 2 Header	J16, J18, J19	SAMTEC, TSW-106-02-S-D
Switches			
3	SPST Push button	S1 - S3	Panasonic, EVQ-PAD05R
Transistors			
1	2N2222A	Q1	ZETEX, FMMT2222ACT
Miscellaneous			
18	Shunt	SH1 - SH13	Samtec, SNT-100-BL-T
4	Rubber Feet	RF1 - RF4	3M, SJ5018BLKC

INDEX

Numerics

1.2 Amp power supply [2-17](#)
 56F8300 Peripheral User Manual [2-4](#)
 56F8357 Technical Data Sheet [2-4](#)
 8.00MHz crystal oscillator [2-1](#)

A

A/D [Preface-ix](#)
 ADC [Preface-ix](#)
 Analog-to-Digital
 A/D [Preface-ix](#)
 Analog-to-Digital Converter
 ADC [Preface-ix](#)

C

CAN [Preface-ix](#)
 bus termination [2-1](#), [2-2](#)
 bypass [2-1](#), [2-2](#)
 interface [2-1](#)
 CAN in Automation
 CiA [Preface-ix](#)
 CAN physical layer peripheral [2-2](#)
 CiA [Preface-ix](#)
 Controller Area Network
 CAN [Preface-ix](#)

D

D/A [Preface-ix](#)
 Daughter Card Expansion
 interface [2-1](#)
 Debugging [2-10](#)
 Digital-to-Analog
 D/A [Preface-ix](#)
 DSP56800E Reference Manual [2-4](#)

E

Enhanced On-Chip Emulation
 EOnCE [Preface-ix](#)
 EOnce [Preface-ix](#)
 Evaluation Module
 EVM [Preface-ix](#)
 EVM [Preface-ix](#)
 External oscillator frequency input [2-1](#)

F

FlexCAN [Preface-ix](#)
 FlexCAN Interface Module
 FlexCAN [Preface-ix](#)
 FSRAM [2-1](#), [2-5](#), [2-6](#)

G

General Purpose Input and Output
 GPIO [Preface-ix](#)
 GPIO [Preface-ix](#), [2-28](#)

H

Host Parallel Interface Connector [2-11](#)
 Host Target Interface [2-11](#)

I

IC [Preface-ix](#)
 Integrated Circuit
 IC [Preface-ix](#)

J

Joint Test Action Group
 JTAG [Preface-ix](#)
 JTAG [Preface-ix](#), [2-1](#)
 JTAG/Enhanced OnCE (EOnCE) [1-1](#)
 Jumper Group [1-4](#)
 JG1 [1-4](#)
 JG10 [1-4](#)
 JG11 [1-4](#)
 JG12 [1-4](#)
 JG13 [1-4](#)
 JG14 [1-4](#)
 JG15 [1-4](#)
 JG16 [1-4](#)
 JG17 [1-4](#)
 JG18 [1-4](#)
 JG19 [1-4](#)
 JG2 [1-4](#)
 JG3 [1-4](#)
 JG4 [1-4](#)
 JG5 [1-4](#)
 JG6 [1-4](#)
 JG7 [1-4](#)
 JG8 [1-4](#)
 JG9 [1-4](#)

L

LED [Preface-ix](#)
 Light Emitting Diode
 LED [Preface-ix](#)
 Low-profile Quad Flat Package
 LQFP [Preface-ix](#)
 LQFP [Preface-ix](#)

M

MPIO [Preface-ix, 2-31](#)
 Multi Purpose Input and Output
 MPIO [Preface-ix](#)

O

On-board power regulation [2-3](#)
 OnCE [Preface-ix](#)
 On-Chip Emulation
 OnCE [Preface-ix](#)

P

Parallel JTAG Host Target Interface [2-1](#)
 PCB [Preface-ix](#)
 peripheral port signals [2-18](#)
 Phase Locked Loop
 PLL [Preface-ix](#)
 PLL [Preface-ix](#)
 Printed Circuit Board
 PCB [Preface-ix](#)
 Pulse Width Modulation
 PWM [Preface-ix](#)
 PWM [Preface-ix](#)
 PWMA-compatible peripheral [2-2](#)
 PWMB-compatible peripheral [2-2](#)

Q

QuadDec [Preface-ix](#)
 Quadrature Decoder
 interface port [2-30](#)
 QuadDec [Preface-ix](#)

R

R/C [Preface-x](#)
 RAM [Preface-x](#)
 Random Access Memory
 RAM [Preface-x](#)
 Read-Only Memory
 ROM [Preface-x](#)
 real-time debugging [2-10](#)
 Resistor/Capacitor Network
 R/C [Preface-x](#)
 ROM [Preface-x](#)
 RS-232 [2-1](#)
 level converter [2-7](#)
 schematic diagram [2-7](#)

S

SCI [Preface-x](#)
 SCI/MPIO-compatible peripheral [2-2](#)
 Serial Communications Interface
 SCI [Preface-x](#)
 Serial Peripheral Interface
 SPI [Preface-x](#)
 SPI [Preface-x](#)
 SPI/MPIO-compatible peripheral [2-2](#)
 SRAM [Preface-x](#)
 external data [2-1](#)
 external program [2-1](#)
 Static Random Access Memory
 SRAM [Preface-x](#)

T

Timer-compatible peripheral [2-2](#)

W

Wait State
 WS [Preface-x](#)
 WS [Preface-x](#)



How to Reach Us:

Home Page:

www.freescale.com

E-mail:

support@freescale.com

USA/Europe or Locations Not Listed:

Freescale Semiconductor
Technical Information Center, CH370
1300 N. Alma School Road
Chandler, Arizona 85224
+1-800-521-6274 or +1-480-768-2130
support@freescale.com

Europe, Middle East, and Africa:

Freescale Halbleiter Deutschland GmbH
Technical Information Center
Schatzbogen 7
81829 Muenchen, Germany
+44 1296 380 456 (English)
+46 8 52200080 (English)
+49 89 92103 559 (German)
+33 1 69 35 48 48 (French)
support@freescale.com

Japan:

Freescale Semiconductor Japan Ltd.
Headquarters
ARCO Tower 15F
1-8-1, Shimo-Meguro, Meguro-ku,
Tokyo 153-0064, Japan
0120 191014 or +81 3 5437 9125
support.japan@freescale.com

Asia/Pacific:

Freescale Semiconductor Hong Kong Ltd.
Technical Information Center
2 Dai King Street
Tai Po Industrial Estate
Tai Po, N.T., Hong Kong
+800 2666 8080
support.asia@freescale.com

For Literature Requests Only:

Freescale Semiconductor Literature Distribution Center
P.O. Box 5405
Denver, Colorado 80217
1-800-441-2447 or 303-675-2140
Fax: 303-675-2150
LDCForFreescaleSemiconductor@hibbertgroup.com

Information in this document is provided solely to enable system and software implementers to use Freescale Semiconductor products. There are no express or implied copyright licenses granted hereunder to design or fabricate any integrated circuits or integrated circuits based on the information in this document.

Freescale Semiconductor reserves the right to make changes without further notice to any products herein. Freescale Semiconductor makes no warranty, representation or guarantee regarding the suitability of its products for any particular purpose, nor does Freescale Semiconductor assume any liability arising out of the application or use of any product or circuit, and specifically disclaims any and all liability, including without limitation consequential or incidental damages. "Typical" parameters that may be provided in Freescale Semiconductor data sheets and/or specifications can and do vary in different applications and actual performance may vary over time. All operating parameters, including "Typicals", must be validated for each customer application by customer's technical experts. Freescale Semiconductor does not convey any license under its patent rights nor the rights of others. Freescale Semiconductor products are not designed, intended, or authorized for use as components in systems intended for surgical implant into the body, or other applications intended to support or sustain life, or for any other application in which the failure of the Freescale Semiconductor product could create a situation where personal injury or death may occur. Should Buyer purchase or use Freescale Semiconductor products for any such unintended or unauthorized application, Buyer shall indemnify and hold Freescale Semiconductor and its officers, employees, subsidiaries, affiliates, and distributors harmless against all claims, costs, damages, and expenses, and reasonable attorney fees arising out of, directly or indirectly, any claim of personal injury or death associated with such unintended or unauthorized use, even if such claim alleges that Freescale Semiconductor was negligent regarding the design or manufacture of the part.



Freescale™ and the Freescale logo are trademarks of Freescale Semiconductor, Inc. All other product or service names are the property of their respective owners. This product incorporates SuperFlash® technology licensed from SST.

© Freescale Semiconductor, Inc. 2005. All rights reserved.

MC56F8367EVMUM
Rev. 2
07/2005



Компания «ЭлектроПласт» предлагает заключение долгосрочных отношений при поставках импортных электронных компонентов на взаимовыгодных условиях!

Наши преимущества:

- Оперативные поставки широкого спектра электронных компонентов отечественного и импортного производства напрямую от производителей и с крупнейших мировых складов;
- Поставка более 17-ти миллионов наименований электронных компонентов;
- Поставка сложных, дефицитных, либо снятых с производства позиций;
- Оперативные сроки поставки под заказ (от 5 рабочих дней);
- Экспресс доставка в любую точку России;
- Техническая поддержка проекта, помощь в подборе аналогов, поставка прототипов;
- Система менеджмента качества сертифицирована по Международному стандарту ISO 9001;
- Лицензия ФСБ на осуществление работ с использованием сведений, составляющих государственную тайну;
- Поставка специализированных компонентов (Xilinx, Altera, Analog Devices, Intersil, Interpoint, Microsemi, Aeroflex, Peregrine, Syfer, Eurofarad, Texas Instrument, Miteq, Cobham, E2V, MA-COM, Hittite, Mini-Circuits, General Dynamics и др.);

Помимо этого, одним из направлений компании «ЭлектроПласт» является направление «Источники питания». Мы предлагаем Вам помощь Конструкторского отдела:

- Подбор оптимального решения, техническое обоснование при выборе компонента;
- Подбор аналогов;
- Консультации по применению компонента;
- Поставка образцов и прототипов;
- Техническая поддержка проекта;
- Защита от снятия компонента с производства.



Как с нами связаться

Телефон: 8 (812) 309 58 32 (многоканальный)

Факс: 8 (812) 320-02-42

Электронная почта: org@eplast1.ru

Адрес: 198099, г. Санкт-Петербург, ул. Калинина, дом 2, корпус 4, литера А.