

TWO OUTPUT DIFFERENTIAL BUFFER FOR PCIE GEN3
9DB233
Description

The 9DB233 zero-delay buffer supports PCIe Gen3 requirements, while being backwards compatible to PCIe Gen2 and Gen1. The 9DB233 is driven by a differential SRC output pair from an IDT 932S421 or 932SQ420 or equivalent main clock generator. It attenuates jitter on the input clock and has a selectable PLL bandwidth to maximize performance in systems with or without Spread-Spectrum clocking. An SMBus interface allows control of the PLL bandwidth and bypass options, while 2 clock request (OE#) pins make the 9DB233 suitable for Express Card applications.

Recommended Application

2 output PCIe Gen3 zero-delay/fanout buffer

Output Features

- 2 - 0.7V current mode differential HCSL output pairs

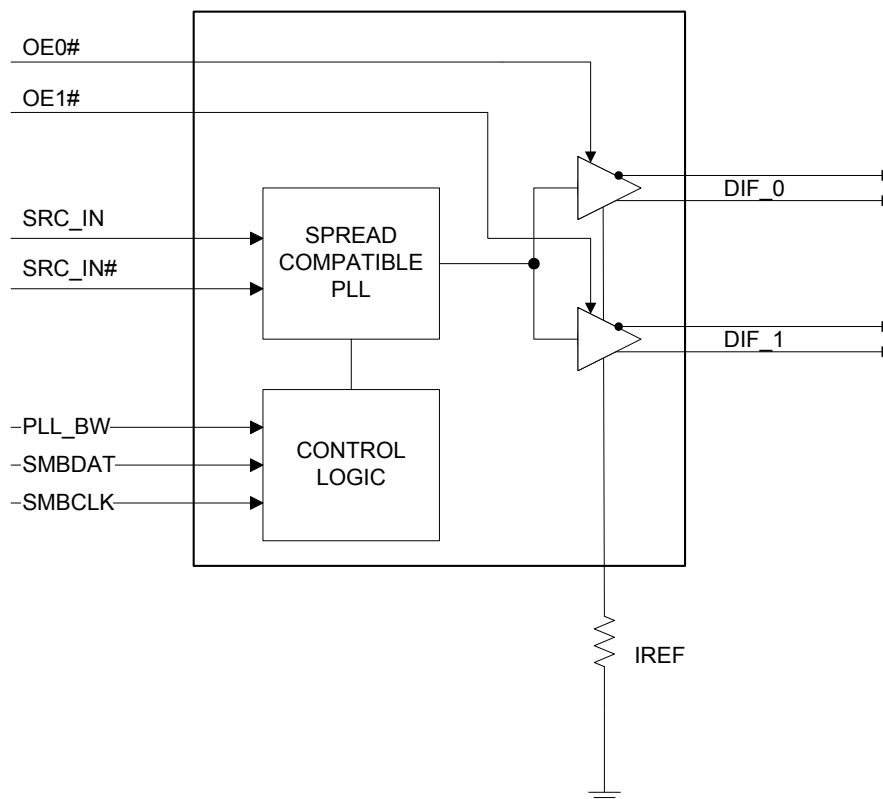
Block Diagram

Features/Benefits

- OE# pins; suitable for Express Card applications
- PLL or bypass mode; PLL can dejitter incoming clock
- Selectable PLL bandwidth; minimizes jitter peaking in downstream PLL's
- Spread Spectrum Compatible; tracks spreading input clock for low EMI
- SMBus Interface; allows control of PLL BW and Mode

Key Specifications

- Cycle-to-cycle jitter < 50 ps
- Output-to-output skew < 50 ps
- PCIe Gen3 phase jitter < 1.0ps RMS

Pin Configuration

PLL_BW	1	9DB233	20	VDDA
SRC_IN	2		19	GNDA
SRC_IN#	3		18	IREF
vOE0#	4		17	vOE1#
VDD	5		16	VDD
GND	6		15	GND
DIF_0	7		14	DIF_1
DIF_0#	8		13	DIF_1#
VDD	9		12	VDD
SMBDAT	10		11	SMBCLK

Note: Pins preceded by ' v ' have internal 120K ohm pull down resistors

Power Distribution Table

Pin Number		Description
VDD	GND	
5,9,12,16	6,15	Differential Outputs
9	6	SMBUS
20	19	IREF
20	19	Analog VDD & GND for PLL core

Pin Descriptions

PIN #	PIN NAME	PIN TYPE	DESCRIPTION
1	PLL_BW	IN	3.3V input for selecting PLL Band Width 0 = low, 1 = high
2	SRC_IN	IN	0.7 V Differential SRC TRUE input
3	SRC_IN#	IN	0.7 V Differential SRC COMPLEMENTARY input
4	vOE0#	IN	Active low input for enabling DIF pair 0. This pin has an internal pull-down. 1 =disable outputs, 0 = enable outputs
5	VDD	PWR	Power supply, nominal 3.3V
6	GND	PWR	Ground pin.
7	DIF_0	OUT	0.7V differential true clock output
8	DIF_0#	OUT	0.7V differential Complementary clock output
9	VDD	PWR	Power supply, nominal 3.3V
10	SMBDAT	I/O	Data pin of SMBUS circuitry, 5V tolerant
11	SMBCLK	IN	Clock pin of SMBUS circuitry, 5V tolerant
12	VDD	PWR	Power supply, nominal 3.3V
13	DIF_1#	OUT	0.7V differential Complementary clock output
14	DIF_1	OUT	0.7V differential true clock output
15	GND	PWR	Ground pin.
16	VDD	PWR	Power supply, nominal 3.3V
17	vOE1#	IN	Active low input for enabling DIF pair 1. This pin has an internal pull-down. 1 =disable outputs, 0 = enable outputs
18	IREF	OUT	This pin establishes the reference for the differential current-mode output pairs. It requires a fixed precision resistor to ground. 475ohm is the standard value for 100ohm differential impedance. Other impedances require different values. See data sheet.
19	GND A	PWR	Ground pin for the PLL core.
20	VDD A	PWR	3.3V power for the PLL core.

Note:

Pins preceded by ' v ' have internal 120K ohm pull down resistors

Absolute Maximum Ratings

Stresses above the ratings listed below can cause permanent damage to the 9DB233. These ratings, which are standard values for IDT commercially rated parts, are stress ratings only. Functional operation of the device at these or any other conditions above those indicated in the operational sections of the specifications is not implied. Exposure to absolute maximum rating conditions for extended periods can affect product reliability. Electrical parameters are guaranteed only over the recommended operating temperature range.

PARAMETER	SYMBOL	CONDITIONS	MIN	TYP	MAX	UNITS	NOTES
3.3V Core Supply Voltage	VDDA				4.6	V	1,2
3.3V Logic Supply Voltage	VDD				4.6	V	1,2
Input Low Voltage	V _{IL}		GND-0.5			V	1
Input High Voltage	V _{IH}	Except for SMBus interface			V _{DD} +0.5V	V	1
Input High Voltage	V _{IHSMB}	SMBus clock and data pins			5.5V	V	1
Storage Temperature	T _s		-65		150	°C	1
Junction Temperature	T _j				125	°C	1
Input ESD protection	ESD prot	Human Body Model	2000			V	1

¹Guaranteed by design and characterization, not 100% tested in production.

²Operation under these conditions is neither implied nor guaranteed.

Electrical Characteristics–DIF_IN Clock Input Parameters

T_{AMB}=T_{COM} or T_{IND} unless otherwise indicated, Supply Voltages per normal operation conditions, See Test Loads for Loading Conditions

PARAMETER	SYMBOL	CONDITIONS	MIN	TYP	MAX	UNITS	NOTES
Input Crossover Voltage - DIF_IN	V _{CROSS}	Cross Over Voltage	150	375	900	mV	1
Input Swing - DIF_IN	V _{SWING}	Differential value	300			mV	1
Input Slew Rate - DIF_IN	dv/dt	Measured differentially	1		8	V/ns	1,2
Input Leakage Current	I _{IN}	V _{IN} = V _{DD} , V _{IN} = GND	-5		5	uA	
Input Duty Cycle	d _{tin}	Measurement from differential waveform	45		55	%	1
Input Jitter - Cycle to Cycle	J _{DIFin}	Differential Measurement	0		125	ps	1

¹Guaranteed by design and characterization, not 100% tested in production.

²Slew rate measured through +/-75mV window centered around differential zero

Electrical Characteristics–Current Consumption

T_A = T_{COM} or T_{IND}; Supply Voltage VDD = 3.3 V +/-5%

PARAMETER	SYMBOL	CONDITIONS	MIN	TYP	MAX	UNITS	NOTES
Operating Supply Current	I _{DD3.3OP}	All outputs active @100MHz, C _L = Full load;		70	80	mA	1
Powerdown Current	I _{DD3.3PD}	All diff pairs driven			N/A	mA	1
	I _{DD3.3PDZ}	All differential pairs tri-stated			N/A	mA	1

¹Guaranteed by design and characterization, not 100% tested in production.

Electrical Characteristics–Input/Supply/Common Parameters

TA = T_{COM} or T_{IND}; Supply Voltage VDD = 3.3 V +/-5%

PARAMETER	SYMBOL	CONDITIONS	MIN	TYP	MAX	UNITS	NOTES
Ambient Operating Temperature	T _{COM}	Commercial range	0		70	°C	1
	T _{IND}	Industrial range	-40		85	°C	1
Input High Voltage	V _{IH}	Single-ended inputs, except SMBus, low threshold and tri-level inputs	2		V _{DD} + 0.3	V	1
Input Low Voltage	V _{IL}	Single-ended inputs, except SMBus, low threshold and tri-level inputs	GND - 0.3		0.8	V	1
Input Current	I _{IN}	Single-ended inputs, V _{IN} = GND, V _{IN} = VDD	-5		5	µA	1
	I _{INP}	Single-ended inputs V _{IN} = 0 V; Inputs with internal pull-up resistors V _{IN} = VDD; Inputs with internal pull-down resistors	-200		200	µA	1
Input Frequency	F _{ibyp}	V _{DD} = 3.3 V, Bypass mode	10		110	MHz	2
	F _{ipll}	V _{DD} = 3.3 V, 100MHz PLL mode	33	100.00	110	MHz	2
Pin Inductance	L _{pin}				7	nH	1
Capacitance	C _{IN}	Logic Inputs, except DIF_IN	1.5		5	pF	1
	C _{INDIF_IN}	DIF_IN differential clock inputs	1.5		2.7	pF	1,4
	C _{OUT}	Output pin capacitance			6	pF	1
Clk Stabilization	T _{STAB}	From V _{DD} Power-Up and after input clock stabilization or de-assertion of PD# to 1st clock		0.800	1.8	ms	1,2
Input SS Modulation Frequency	f _{MODIN}	Allowable Frequency (Triangular Modulation)	30		33	kHz	1
OE# Latency	t _{LATOE#}	DIF start after OE# assertion DIF stop after OE# deassertion	1		3	cycles	1,3
Tdrive_PD#	t _{DRVPD}	DIF output enable after PD# de-assertion			300	µs	1,3
Tfall	t _F	Fall time of control inputs			5	ns	1,2
Trise	t _R	Rise time of control inputs			5	ns	1,2
SMBus Input Low Voltage	V _{ILSMB}				0.8	V	1
SMBus Input High Voltage	V _{IHSMB}		2.1		V _{DD} SMB	V	1
SMBus Output Low Voltage	V _{OLSMB}	@ I _{PULLUP}			0.4	V	1
SMBus Sink Current	I _{PULLUP}	@ V _{OL}	4			mA	1
Nominal Bus Voltage	V _{DD} SMB	3V to 5V +/- 10%	2.7		5.5	V	1
SCLK/SDATA Rise Time	t _{RSMB}	(Max VIL - 0.15) to (Min VIH + 0.15)			1000	ns	1
SCLK/SDATA Fall Time	t _{FSMB}	(Min VIH + 0.15) to (Max VIL - 0.15)			300	ns	1
SMBus Operating Frequency	f _{MAXSMB}	Maximum SMBus operating frequency			100	kHz	1,5

¹Guaranteed by design and characterization, not 100% tested in production.

²Control input must be monotonic from 20% to 80% of input swing.

³Time from deassertion until outputs are >200 mV

⁴DIF_IN input

⁵The differential input clock must be running for the SMBus to be active

Electrical Characteristics–DIF 0.7V Current Mode Differential Outputs

$T_A = T_{COM}$ or T_{IND} ; Supply Voltage $V_{DD} = 3.3\text{ V} \pm 5\%$

PARAMETER	SYMBOL	CONDITIONS	MIN	TYP	MAX	UNITS	NOTES
Slew rate	Trf	Scope averaging on	0.6	2	4	V/ns	1, 2, 3
Slew rate matching	ΔTrf	Slew rate matching, Scope averaging on		4.2	20	%	1, 2, 4
Voltage High	VHigh	Statistical measurement on single-ended signal using oscilloscope math function. (Scope averaging on)	660	791	850	mV	1
Voltage Low	VLow		-150	13	150		1
Max Voltage	Vmax	Measurement on single ended signal using absolute value. (Scope averaging off)		801	1150	mV	1
Min Voltage	Vmin		-300	5			1
Vswing	Vswing	Scope averaging off	300	1557		mV	1, 2
Crossing Voltage (abs)	Vcross_abs	Scope averaging off	250	367	550	mV	1, 5
Crossing Voltage (var)	Δ -Vcross	Scope averaging off		46	140	mV	1, 6

¹Guaranteed by design and characterization, not 100% tested in production. $I_{REF} = V_{DD}/(3 \times R_R)$. For $R_R = 475\Omega$ (1%), $I_{REF} = 2.32\text{mA}$.

$I_{OH} = 6 \times I_{REF}$ and $V_{OH} = 0.7\text{V}$ @ $Z_O=50\Omega$ (100 Ω differential impedance).

² Measured from differential waveform

³ Slew rate is measured through the Vswing voltage range centered around differential 0V. This results in a +/-150mV window around differential 0V.

⁴ Matching applies to rising edge rate for Clock and falling edge rate for Clock#. It is measured using a +/-75mV window centered on the average cross point where Clock rising meets Clock# falling. The median cross point is used to calculate the voltage thresholds the oscilloscope is to use for the edge rate calculations.

⁵ Vcross is defined as voltage where Clock = Clock# measured on a component test board and only applies to the differential rising edge (i.e. Clock rising and Clock# falling).

⁶ The total variation of all Vcross measurements in any particular system. Note that this is a subset of V_cross_min/max (V_cross absolute) allowed. The intent is to limit Vcross induced modulation by setting V_cross_delta to be smaller than V_cross absolute.

Electrical Characteristics–Output Duty Cycle, Jitter, Skew and PLL Characteristics

$T_A = T_{COM}$ or T_{IND} ; Supply Voltage $V_{DD} = 3.3\text{ V} \pm 5\%$

PARAMETER	SYMBOL	CONDITIONS	MIN	TYP	MAX	UNITS	NOTES
PLL Bandwidth	BW	-3dB point in High BW Mode	2	2.2	4	MHz	1
		-3dB point in Low BW Mode	0.4	0.5	1	MHz	1
PLL Jitter Peaking	t_{JPEAK}	Peak Pass band Gain		0.6	1.5	dB	1
Duty Cycle	t_{DC}	Measured differentially, PLL Mode	45	48	55	%	1
Duty Cycle Distortion	t_{DCD}	Measured differentially, Bypass Mode @100MHz	-2	0.4	2	%	1,4
Skew, Input to Output	t_{pdBYP}	Bypass Mode, $V_T = 50\%$	2500	3660	4500	ps	1
	t_{pdPLL}	Hi BW PLL Mode $V_T = 50\%$	-50	136	350	ps	1
Skew, Output to Output	t_{sk3}	$V_T = 50\%$		16	50	ps	1
Jitter, Cycle to cycle	$t_{j\text{cyc-cyc}}$	PLL mode		29	50	ps	1,3
		Additive Jitter in Bypass Mode		0.2	50	ps	1,3

¹Guaranteed by design and characterization, not 100% tested in production.

² $I_{REF} = V_{DD}/(3 \times R_R)$. For $R_R = 475\Omega$ (1%), $I_{REF} = 2.32\text{mA}$. $I_{OH} = 6 \times I_{REF}$ and $V_{OH} = 0.7\text{V}$ @ $Z_O=50\Omega$.

³ Measured from differential waveform

⁴ Duty cycle distortion is the difference in duty cycle between the output and the input clock when the device is operated in bypass mode.

Electrical Characteristics–PCIe Phase Jitter Parameters

TA = T_{COM} or T_{IND}; Supply Voltage VDD = 3.3 V +/-5%

PARAMETER	SYMBOL	CONDITIONS	MIN	TYP	MAX	UNITS	Notes
Phase Jitter, PLL Mode	t _{jphPCIeG1}	PCIe Gen 1		34	86	ps (p-p)	1,2,3
	t _{jphPCIeG2}	PCIe Gen 2 Lo Band 10kHz < f < 1.5MHz		1	3	ps (rms)	1,2
		PCIe Gen 2 High Band 1.5MHz < f < Nyquist (50MHz)		2	3.1	ps (rms)	1,2
	t _{jphPCIeG3}	PCIe Gen 3 (PLL BW of 2-4MHz, CDR = 10MHz)		1	1	ps (rms)	1,2,4
Additive Phase Jitter, Bypass Mode	t _{jphPCIeG1}	PCIe Gen 1		2	5	ps (p-p)	1,2,3
	t _{jphPCIeG2}	PCIe Gen 2 Lo Band 10kHz < f < 1.5MHz		0.2	0.3	ps (rms)	1,2
		PCIe Gen 2 High Band 1.5MHz < f < Nyquist (50MHz)		0.1	0.2	ps (rms)	1,2
	t _{jphPCIeG3}	PCIe Gen 3 (PLL BW of 2-4MHz, CDR = 10MHz)		0.1	0.2	ps (rms)	1,2,4

¹ Applies to all outputs.

² See <http://www.pcisig.com> for complete specs

³ Sample size of at least 100K cycles. This figures extrapolates to 108ps pk-pk @ 1M cycles for a BER of 1-12.

⁴ Subject to final ratification by PCI SIG.

SRC Reference Clock			
Common Recommendations for Differential Routing	Dimension or Value	Unit	Figure
L1 length, route as non-coupled 50ohm trace	0.5 max	inch	1
L2 length, route as non-coupled 50ohm trace	0.2 max	inch	1
L3 length, route as non-coupled 50ohm trace	0.2 max	inch	1
Rs	33	ohm	1
Rt	49.9	ohm	1

Down Device Differential Routing			
L4 length, route as coupled microstrip 100ohm differential trace	2 min to 16 max	inch	1
L4 length, route as coupled stripline 100ohm differential trace	1.8 min to 14.4 max	inch	1

Differential Routing to PCI Express Connector			
L4 length, route as coupled microstrip 100ohm differential trace	0.25 to 14 max	inch	2
L4 length, route as coupled stripline 100ohm differential trace	0.225 min to 12.6 max	inch	2

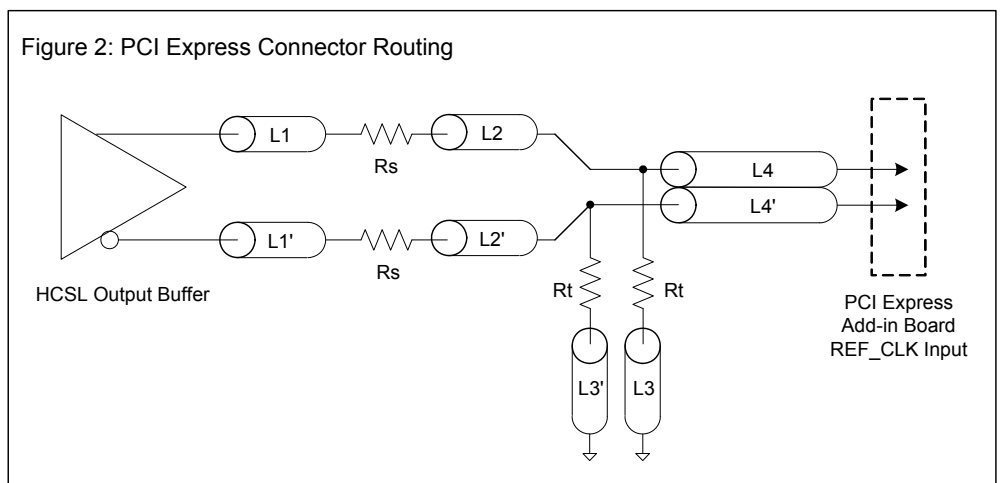
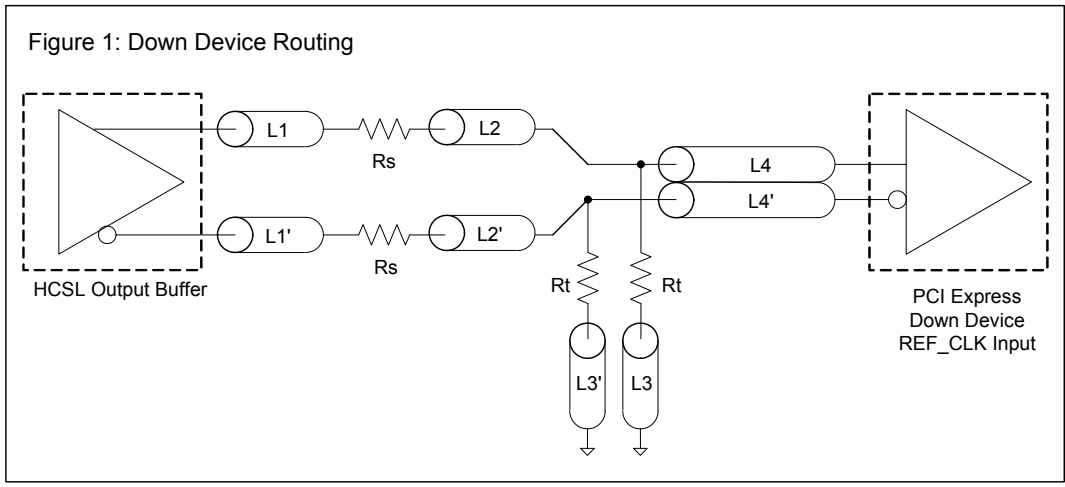

Alternative Termination for LVDS and other Common Differential Signals (figure 3)							
Vdiff	Vp-p	Vcm	R1	R2	R3	R4	Note
0.45v	0.22v	1.08	33	150	100	100	
0.58	0.28	0.6	33	78.7	137	100	
0.80	0.40	0.6	33	78.7	none	100	ICS874003i-02 input compatible
0.60	0.3	1.2	33	174	140	100	Standard LVDS

R1a = R1b = R1

R2a = R2b = R2

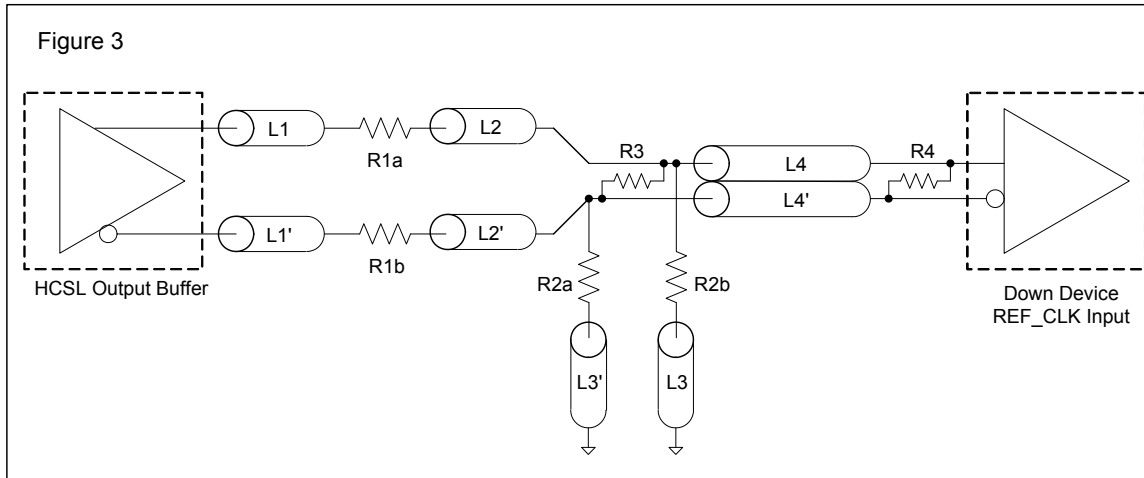

Cable Connected AC Coupled Application (figure 4)		
Component	Value	Note
R5a, R5b	8.2K 5%	
R6a, R6b	1K 5%	
Cc	0.1 μ F	
Vcm	0.350 volts	

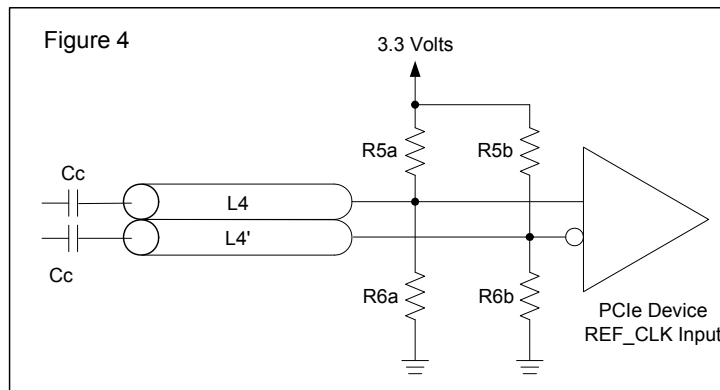

General SMBus Serial Interface Information for 9DB233

How to Write

- Controller (host) sends a start bit
- Controller (host) sends the write address
- IDT clock will **acknowledge**
- Controller (host) sends the beginning byte location = N
- IDT clock will **acknowledge**
- Controller (host) sends the byte count = X
- IDT clock will **acknowledge**
- Controller (host) starts sending Byte N through Byte N+X-1
- IDT clock will **acknowledge** each byte **one at a time**
- Controller (host) sends a Stop bit

Index Block Write Operation		
Controller (Host)		IDT (Slave/Receiver)
T	starT bit	
Slave Address		
WR	WRite	
Beginning Byte = N		ACK
		ACK
Data Byte Count = X		ACK
Beginning Byte N		ACK
O	X Byte	O
O		O
O		O
Byte N + X - 1		ACK
P	stoP bit	

Read Address	Write Address
D5 _(H)	D4 _(H)

How to Read

- Controller (host) will send a start bit
- Controller (host) sends the write address
- IDT clock will **acknowledge**
- Controller (host) sends the beginning byte location = N
- IDT clock will **acknowledge**
- Controller (host) will send a separate start bit
- Controller (host) sends the read address
- IDT clock will **acknowledge**
- IDT clock will send the data byte count = X
- IDT clock sends Byte N+X-1
- IDT clock sends **Byte 0 through Byte X (if X_(H) was written to Byte 8)**
- Controller (host) will need to acknowledge each byte
- Controller (host) will send a not acknowledge bit
- Controller (host) will send a stop bit

Index Block Read Operation		
Controller (Host)		IDT (Slave/Receiver)
T	starT bit	
Slave Address		
WR	WRite	
Beginning Byte = N		ACK
		ACK
RT	Repeat starT	
Slave Address		
RD	ReaD	
		ACK
ACK		Data Byte Count=X
		Beginning Byte N
ACK		O
O		O
O		O
O		
		Byte N + X - 1
N	Not acknowledge	
P	stoP bit	

SMBus Table: Device Control Register, READ/WRITE ADDRESS (D5/D4)

Byte 0	Pin #	Name	Control Function	Type	0	1	Default
Bit 7	-	SW_EN	Enables SMBus Control of bite 1 and 0	RW	PLL Functions controlled by SMBus registers	PLL Functions controlled by device pins	1
Bit 6	-	RESERVED		RW	-	-	X
Bit 5	-	RESERVED		RW	-	-	X
Bit 4	-	RESERVED		RW	-	-	X
Bit 3	-	RESERVED		RW	-	-	X
Bit 2	-	RESERVED		RW	-	-	X
Bit 1	-	PLL BW #adjust	Selects PLL Bandwidth	RW	Low BW	High BW	1
Bit 0	-	PLL Enable	Bypasses PLL for board test	RW	PLL bypassed (fan out mode)	PLL enabled (ZDB mode)	1

SMBus Table: Output Enable Register

Byte 1	Pin #	Name	Control Function	Type	0	1	Default
Bit 7	-	RESERVED		RW	-	-	X
Bit 6	-	RESERVED		RW	-	-	X
Bit 5	-	RESERVED		RW	-	-	X
Bit 4	-	RESERVED		RW	-	-	X
Bit 3	-	RESERVED		RW	-	-	X
Bit 2	-	RESERVED		RW	-	-	X
Bit 1	-	RESERVED		RW	-	-	X
Bit 0	-	RESERVED		RW	-	-	X

SMBus Table: Function Select Register

Byte 2	Pin #	Name	Control Function	Type	0	1	Default
Bit 7	-	RESERVED		RW	-	-	X
Bit 6	-	RESERVED		RW	-	-	X
Bit 5	-	RESERVED		RW	-	-	X
Bit 4	-	RESERVED		RW	-	-	X
Bit 3	-	RESERVED		RW	-	-	X
Bit 2	-	RESERVED		RW	-	-	X
Bit 1	-	RESERVED		RW	-	-	X
Bit 0	-	RESERVED		RW	-	-	X

SMBus Table: Vendor & Revision ID Register

Byte 3	Pin #	Name	Control Function	Type	0	1	Default
Bit 7	-	RID3	REVISION ID	R	-	-	0
Bit 6	-	RID2		R	-	-	0
Bit 5	-	RID1		R	-	-	0
Bit 4	-	RID0		R	-	-	1
Bit 3	-	VID3	VENDOR ID	R	-	-	0
Bit 2	-	VID2		R	-	-	0
Bit 1	-	VID1		R	-	-	0
Bit 0	-	VID0		R	-	-	1

SMBus Table: DEVICE ID

Byte 4	Pin #	Name	Control Function	Type	0	1	Default
Bit 7	-	Device ID = 06 Hex		R	-	-	0
Bit 6	-			R	-	-	0
Bit 5	-			R	-	-	0
Bit 4	-			R	-	-	0
Bit 3	-			R	-	-	0
Bit 2	-			R	-	-	1
Bit 1	-			R	-	-	1
Bit 0	-			R	-	-	0

SMBus Table: Byte Count Register

Byte 5	Pin #	Name	Control Function	Type	0	1	Default
Bit 7	-	BC7	Writing to this register will configure how many bytes will be read back, default is 06 = 6 bytes.	RW	-	-	0
Bit 6	-	BC6		RW	-	-	0
Bit 5	-	BC5		RW	-	-	0
Bit 4	-	BC4		RW	-	-	0
Bit 3	-	BC3		RW	-	-	0
Bit 2	-	BC2		RW	-	-	1
Bit 1	-	BC1		RW	-	-	1
Bit 0	-	BC0		RW	-	-	0

Marking Diagrams

20-pin SSOP

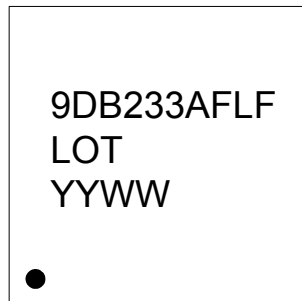
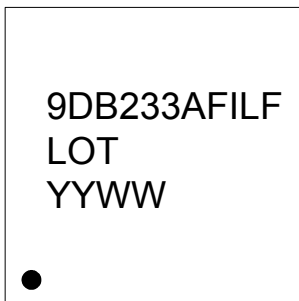

20-pin TSSOP

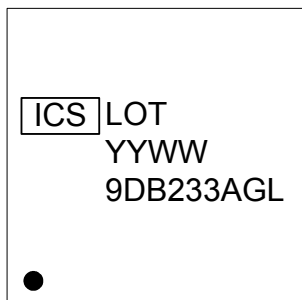
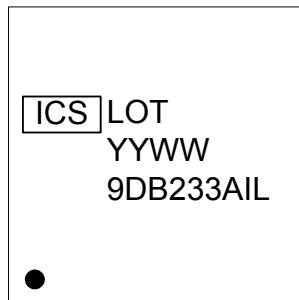

Notes:

1. "LOT" is the lot number.
2. "YYWW" is the last two digits of the year and week that the part was assembled.
3. "L" or "LF" denotes RoHS compliant package.
4. "I" denotes industrial temperature.
5. Bottom marking: country of origin if not USA.

Package Outline and Package Dimensions (20-pin SSOP, 150 Mil. Wide Body)

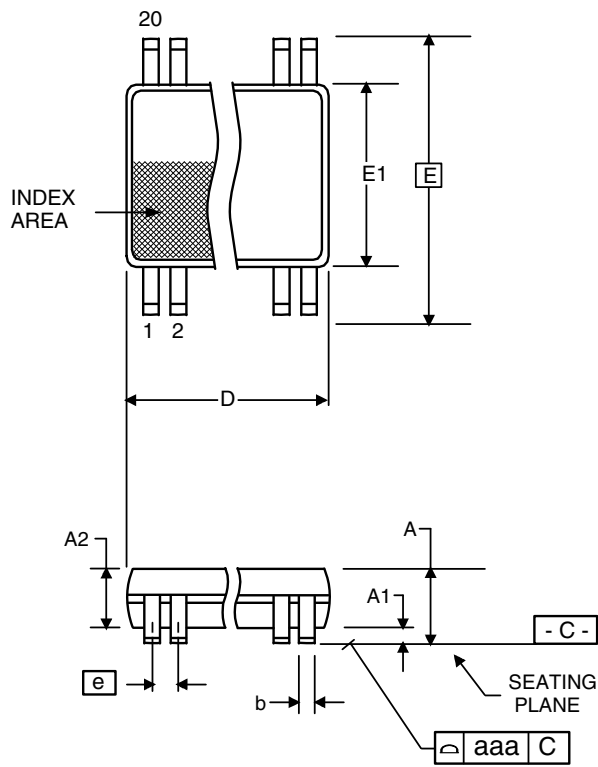

Symbol	Millimeters		Inches	
	Min	Max	Min	Max
A	1.35	1.75	0.053	0.069
A1	0.10	0.25	0.004	0.010
A2	--	1.50	--	0.059
b	0.20	0.30	0.008	0.012
c	0.18	0.25	0.007	0.010
D	8.55	8.75	0.337	0.344
E	5.80	6.20	0.228	0.244
E1	3.80	4.00	0.150	0.157
e	.635 Basic		.025 Basic	
L	0.40	1.27	0.016	0.050
α	0°	8°	0°	8°
aaa	--	0.10	--	0.004

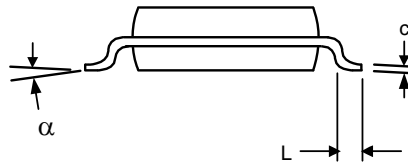

Package Outline and Package Dimensions (20-pin TSSOP, 4.4mm Narrow Body)

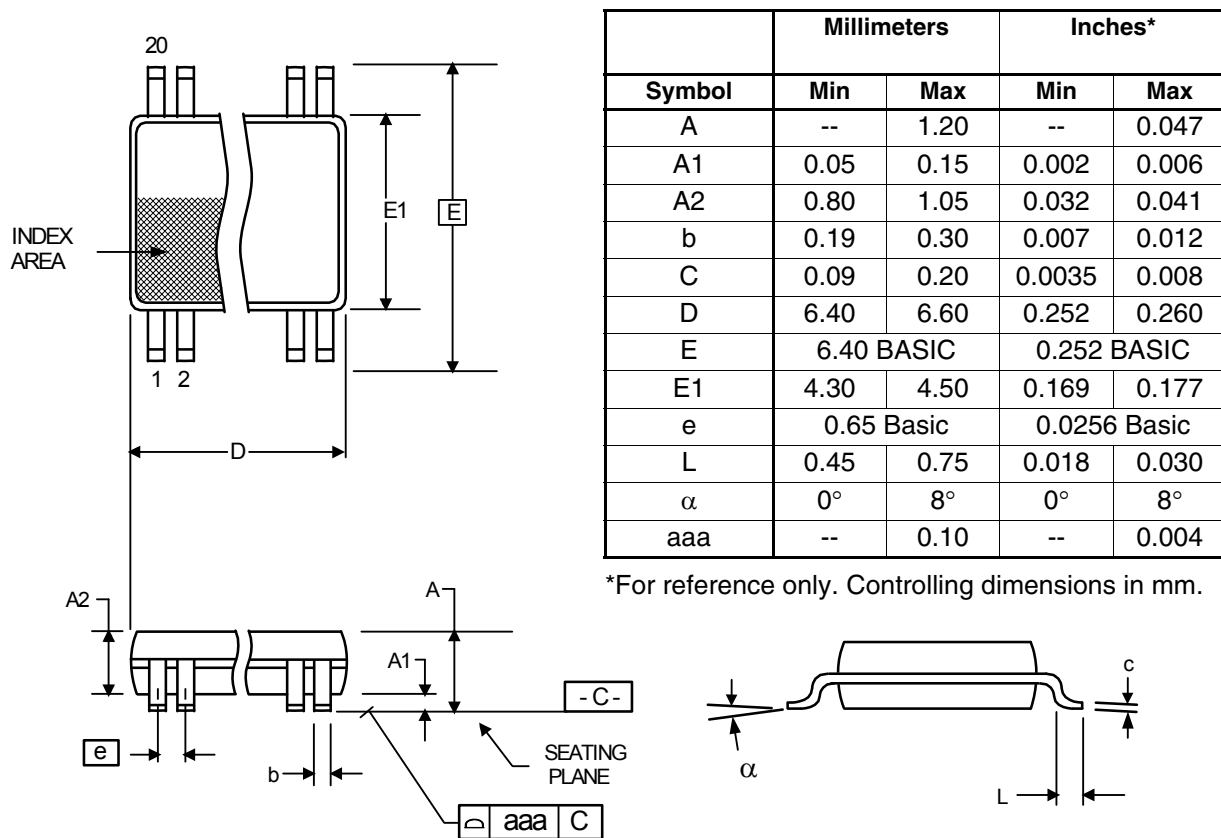

Ordering Information

Part / Order Number	Shipping Packaging	Package	Temperature
9DB233AFLF	Tubes	20-pin SSOP	0 to +70°C
9DB233AFLFT	Tape and Reel	20-pin SSOP	0 to +70°C
9DB233AFILF	Tubes	20-pin SSOP	-40 to +85°C
9DB233AFILFT	Tape and Reel	20-pin SSOP	-40 to +85°C
9DB233AGLF	Tubes	20-pin TSSOP	0 to +70°C
9DB233AGLFT	Tape and Reel	20-pin TSSOP	0 to +70°C
9DB233AGILF	Tubes	20-pin TSSOP	-40 to +85°C
9DB233AGILFT	Tape and Reel	20-pin TSSOP	-40 to +85°C

"LF" suffix to the part number are the Pb-Free configuration and are RoHS compliant.

"A" is the device revision designator (will not correlate with the datasheet revision).

While the information presented herein has been checked for both accuracy and reliability, Integrated Device Technology (IDT) assumes no responsibility for either its use or for the infringement of any patents or other rights of third parties, which would result from its use. No other circuits, patents, or licenses are implied. This product is intended for use in normal commercial applications. Any other applications such as those requiring extended temperature range, high reliability, or other extraordinary environmental requirements are not recommended without additional processing by IDT. IDT does not authorize or warrant any IDT product for use in life support devices or critical medical instruments.

Revision History

Rev.	Who	Issue Date	Description	Page #
A	RDW	6/30/2010	Released to final	
B	RDW	7/12/2010	1. Changed PWD to Default in SMBus tables.	10,11
C	RDW	4/14/2011	Changed pull down indicator from '**' to 'v'.	
D	RDW	4/9/2012	1. Updated typical electrical characteristics to reflect improved performance	3-6
E	RDW	2/19/2014	1. Corrected typo for Read/Write address from D4/D5 to D5/D4 respectively. 2. Added device marking diagrams.	Various
F	RDW	10/20/2016	Updated input clock electrical table to latest format. No change to form, fit or function of the device	4

9DB233

TWO OUTPUT DIFFERENTIAL BUFFER FOR PCIE GEN3

Innovate with IDT and accelerate your future networks. Contact:

www.IDT.com

For Sales

800-345-7015
408-284-8200
Fax: 408-284-2775

For Tech Support

www.idt.com/go/support

Corporate Headquarters

Integrated Device Technology, Inc.
www.idt.com





Компания «ЭлектроПласт» предлагает заключение долгосрочных отношений при поставках импортных электронных компонентов на взаимовыгодных условиях!

Наши преимущества:

- Оперативные поставки широкого спектра электронных компонентов отечественного и импортного производства напрямую от производителей и с крупнейших мировых складов;
- Поставка более 17-ти миллионов наименований электронных компонентов;
- Поставка сложных, дефицитных, либо снятых с производства позиций;
- Оперативные сроки поставки под заказ (от 5 рабочих дней);
- Экспресс доставка в любую точку России;
- Техническая поддержка проекта, помощь в подборе аналогов, поставка прототипов;
- Система менеджмента качества сертифицирована по Международному стандарту ISO 9001;
- Лицензия ФСБ на осуществление работ с использованием сведений, составляющих государственную тайну;
- Поставка специализированных компонентов (Xilinx, Altera, Analog Devices, Intersil, Interpoint, Microsemi, Aeroflex, Peregrine, Syfer, Eurofarad, Texas Instrument, Miteq, Cobham, E2V, MA-COM, Hittite, Mini-Circuits, General Dynamics и др.);

Помимо этого, одним из направлений компании «ЭлектроПласт» является направление «Источники питания». Мы предлагаем Вам помощь Конструкторского отдела:

- Подбор оптимального решения, техническое обоснование при выборе компонента;
- Подбор аналогов;
- Консультации по применению компонента;
- Поставка образцов и прототипов;
- Техническая поддержка проекта;
- Защита от снятия компонента с производства.



Как с нами связаться

Телефон: 8 (812) 309 58 32 (многоканальный)

Факс: 8 (812) 320-02-42

Электронная почта: org@eplast1.ru

Адрес: 198099, г. Санкт-Петербург, ул. Калинина, дом 2, корпус 4, литера А.