

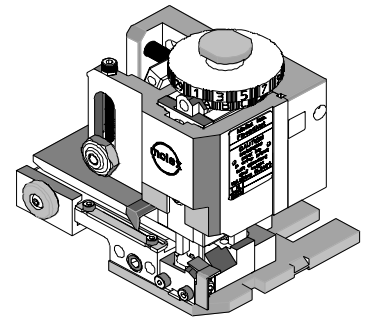

FineAdjust Applicator Specification Sheet Part No. 63860-9000



FEATURES

- Quick punch removal with the push of a button for fast and easy tooling change
- Applicator designed to industry standard mounting and shut height 135.80mm (5.346")
- Quick set-up time; plus the crimp height, track and feed adjustments can be set without removing the applicator from the press
- Fine adjustment allows users to achieve target with little effort by adjusting in increments of 0.15mm (.0006") for conductor crimp height and .063mm (.0025") for insulation height
- Independent adjustment rings allow users to quickly adjust the conductor or insulation crimp height without affecting each other
- Directly adapts to most automatic wire processing machines

SCOPE

Terminal Series No.	Wire Size		Insulation Diameter		Strip Length	
	AWG	mm ²	mm	In.	mm	In.
35069-*00*	18	0.80	3.60 Max	.142 Max	3.00-3.50	.118-.138

DEFINITION OF TERMS

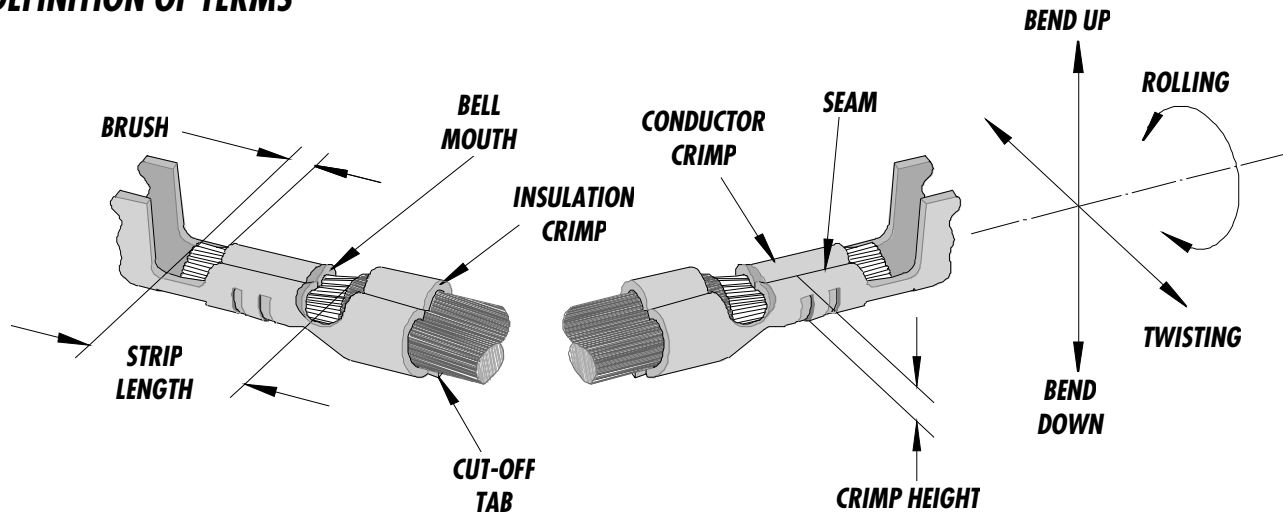

The above terminal drawing is a generic terminal representation. It is not an image of a terminal listed in the scope.

CRIMP SPECIFICATION

Terminal Series No.	Bell mouth		Cut-off Tab Max.		Conductor Brush	
	mm	In.	mm	In.	mm	In.
35069-*00*	0.20-0.70	.008-.028	0.30	.012	0.00-1.00	.000-.039

Terminal Series No.	Bend up	Bend down	Twist	Roll	Punch Width mm (Ref)				Seam Seam shall not be open and no wire allowed out of the crimping area
	Degree		Degree		Conductor		Insulation		
					mm	In	mm	In	
35069-*00*	4	2	3	8	1.80	.070	3.60	.144	

The above specifications are guidelines to an optimum crimp.

CONDITIONS

After crimping, the conductor profile should measure the following.

Terminal Series No.	Wire Size		Crimp Height		Pull Force Min.	
	AWG	mm ²	mm	In.	N	Lb.
35069-*00*	18	0.80	1.08-1.18	.042-.046	88.0	19.8

Pull Force should be measured with no influence from the insulation crimp.

PARTS LIST

Item	Order No	Engineering No.	Description	Quantity
	63860-9000	63860-9000	FineAdjust Applicator (Fig. 1)	REF
1	63444-1816	63444-1816	Conductor Punch	1 Y
2	63445-1831	63445-1831	Conductor Anvil	1 Y
3	63446-3619	63446-3619	Insulation Punch	1 Y
4	63445-3604	63445-3604	Insulation Anvil	1 Y
5	63443-0002	63443-0002	Cut-Off Plunger	1 Y
6	63443-0012	63443-0012	Front Plunger Retainer	1 Y
7	11-24-1067	4996-4	Cut-Off Plunger Spring	1
8	11-40-4039	8302-5	Front Plunger Striker	1
9	63443-0021	63443-0021	Lower Tooling Key	1
10	63443-6003	63443-6003	Rear Cover	1
11	11-18-4094	60709A111	Front Cover	1
12	63443-2409	63443-2409	Anvil Mount	1
13	63443-4005	63443-4005	Wire Stop	1
14	63443-0009	63443-0009	Scrap Chute	1
15	63800-4900	63800-4900	FineAdjust Applicator	1
16	63860-2015	63860-2015	* Drag Frame (Modified)	1
17	N/A	N/A	M3 by 6Lg. SHCS	2**
18	N/A	N/A	M4 by 6Lg. SHCS	1**
19	N/A	N/A	M4 by 12Lg. BHCS	2**
20	N/A	N/A	M4 by 16Lg SHCS	1**
21	N/A	N/A	M4 by 20Lg. SHCS	1**
22	N/A	N/A	M4 by 50Lg. SHCS	1**
23	N/A	N/A	3MM by 6Lg. Roll Pin	1**
24	N/A	N/A	#10-32 by 1/4"Lg. BHCS	1**
	63860-9070	63860-9070	Tool Kit (All Y Items)	REF

*** Frame part - To be modified.**

**** The following purchased parts are available from an Industrial supply company such as MSC (1-800-645-7270).**

Assembly Drawing

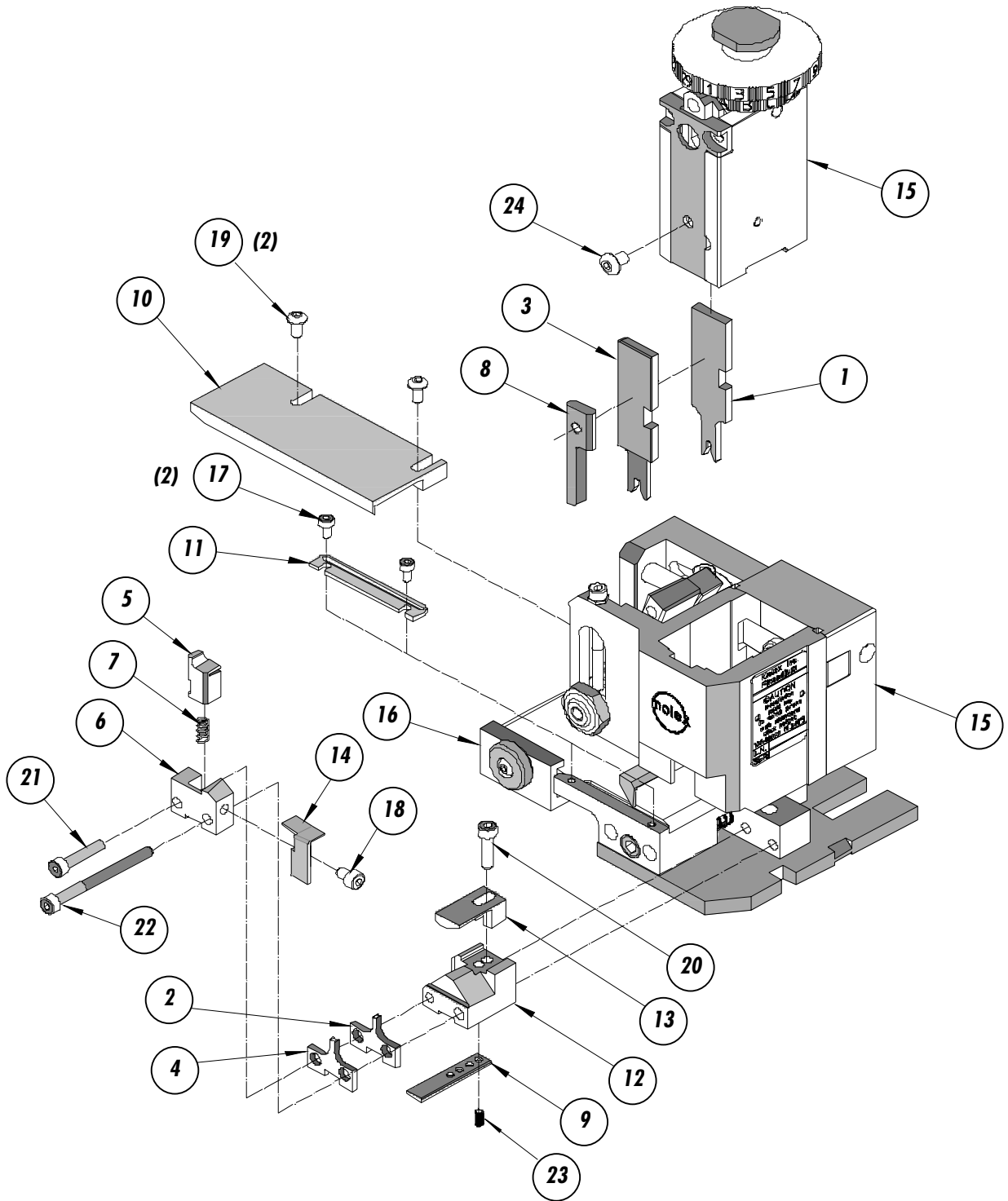

Figure 1

NOTES

1. Molex recommends an extra perishable tooling kit be maintained at your facility.
2. Verify tooling alignment by manually cycling the press and Applicator before crimping under power. Check that all screws are tight.
3. Slugs, Terminals, Dirt and Oil should be kept clear of work area.
4. Wear safety glasses at all times.
5. For recommended maintenance refer to the FineAdjust Manual.

CAUTION: This applicator should only be used in a press with a shut height of 135.8 mm (5.346"). Tooling damage could result at a lower setting.

CAUTION: To prevent injury never operate this Applicator without the guards supplied with the press or wire-processing machine in place. Reference the press or wire processing manufacturer's instruction manual.

CAUTION: Molex crimp specifications are valid only when used with Molex terminals, applicators and tooling.

**Molex Application Tooling Group
1150 E. Diehl Road
Naperville, IL 60563
Tel: (630) 969-4550
Fax: (630) 505-0049**

Visit our Web site at <http://www.molex.com>



Компания «ЭлектроПласт» предлагает заключение долгосрочных отношений при поставках импортных электронных компонентов на взаимовыгодных условиях!

Наши преимущества:

- Оперативные поставки широкого спектра электронных компонентов отечественного и импортного производства напрямую от производителей и с крупнейших мировых складов;
- Поставка более 17-ти миллионов наименований электронных компонентов;
- Поставка сложных, дефицитных, либо снятых с производства позиций;
- Оперативные сроки поставки под заказ (от 5 рабочих дней);
- Экспресс доставка в любую точку России;
- Техническая поддержка проекта, помощь в подборе аналогов, поставка прототипов;
- Система менеджмента качества сертифицирована по Международному стандарту ISO 9001;
- Лицензия ФСБ на осуществление работ с использованием сведений, составляющих государственную тайну;
- Поставка специализированных компонентов (Xilinx, Altera, Analog Devices, Intersil, Interpoint, Microsemi, Aeroflex, Peregrine, Syfer, Eurofarad, Texas Instrument, Miteq, Cobham, E2V, MA-COM, Hittite, Mini-Circuits, General Dynamics и др.);

Помимо этого, одним из направлений компании «ЭлектроПласт» является направление «Источники питания». Мы предлагаем Вам помощь Конструкторского отдела:

- Подбор оптимального решения, техническое обоснование при выборе компонента;
- Подбор аналогов;
- Консультации по применению компонента;
- Поставка образцов и прототипов;
- Техническая поддержка проекта;
- Защита от снятия компонента с производства.



Как с нами связаться

Телефон: 8 (812) 309 58 32 (многоканальный)

Факс: 8 (812) 320-02-42

Электронная почта: org@eplast1.ru

Адрес: 198099, г. Санкт-Петербург, ул. Калинина, дом 2, корпус 4, литера А.