

IFX21004TN V51

Dual Voltage Regulator with 5 V and 15 V Outputs

IFX21004TN V51

Data Sheet

Rev. 1.00, 2010-11-04

Standard Power



1 Overview

Features

- Dual Output: 5 V and 15 V
- High Input Voltage Range: up to 60 V Peak
- High Output Current Capability 100 mA and 30 mA
- High Output Voltage Accuracy
- Very low Current Consumption
- Overtemperature Shutdown
- Thermal Optimized Package
- Green Product (RoHS compliant)

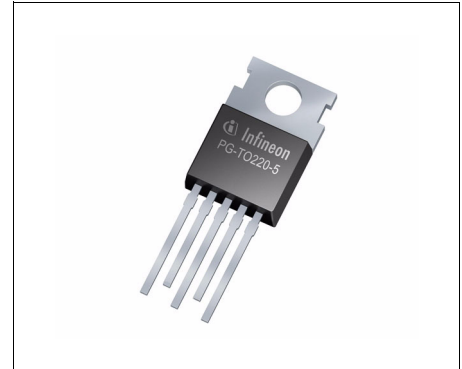

PG-TO220-5

For automotive applications please refer to the Infineon TLE- and TLF-series voltage regulators.

Description

The **IFX21004TN V51** is a monolithic integrated voltage regulator providing two output voltages: Output Q1 is a 5 V output for loads up to 100 mA and output Q2 is a 15 V output providing up to 30 mA. The device is available in the **PG-TO220-5** package.

The **IFX21004TN V51** is designed to supply any system that requires 5 V and 15 V. These can be for example systems with a microcontroller (5 V) and a standard MOS-driver-IC (15 V). To fulfill also the requirements of severe operating conditions the IFX21004TN V51 is able to operate across a wide junction temperature range of $-40\text{ }^{\circ}\text{C} < T_j < 150\text{ }^{\circ}\text{C}$ and is also equipped with additional protection functions.

Both outputs are protected against overload by an integrated output current limitation circuit. The built-in overtemperature shutdown circuit protects the device against overheating.

The IC operates across a wide input voltage range from 20 V up to 60 V peak and up to 40V for continuous operation. The output voltages are regulated to $V_{Q1} = 5\text{ V}$ and $V_{Q2} = 15\text{ V}$. The standard **PG-TO220-5** package is especially suitable for this kind of application, as it reduces system cost and provides excellent thermal characteristics.

Type	Package	Marking
IFX21004TN V51	PG-TO220-5	IFX21004

2 Block Diagram

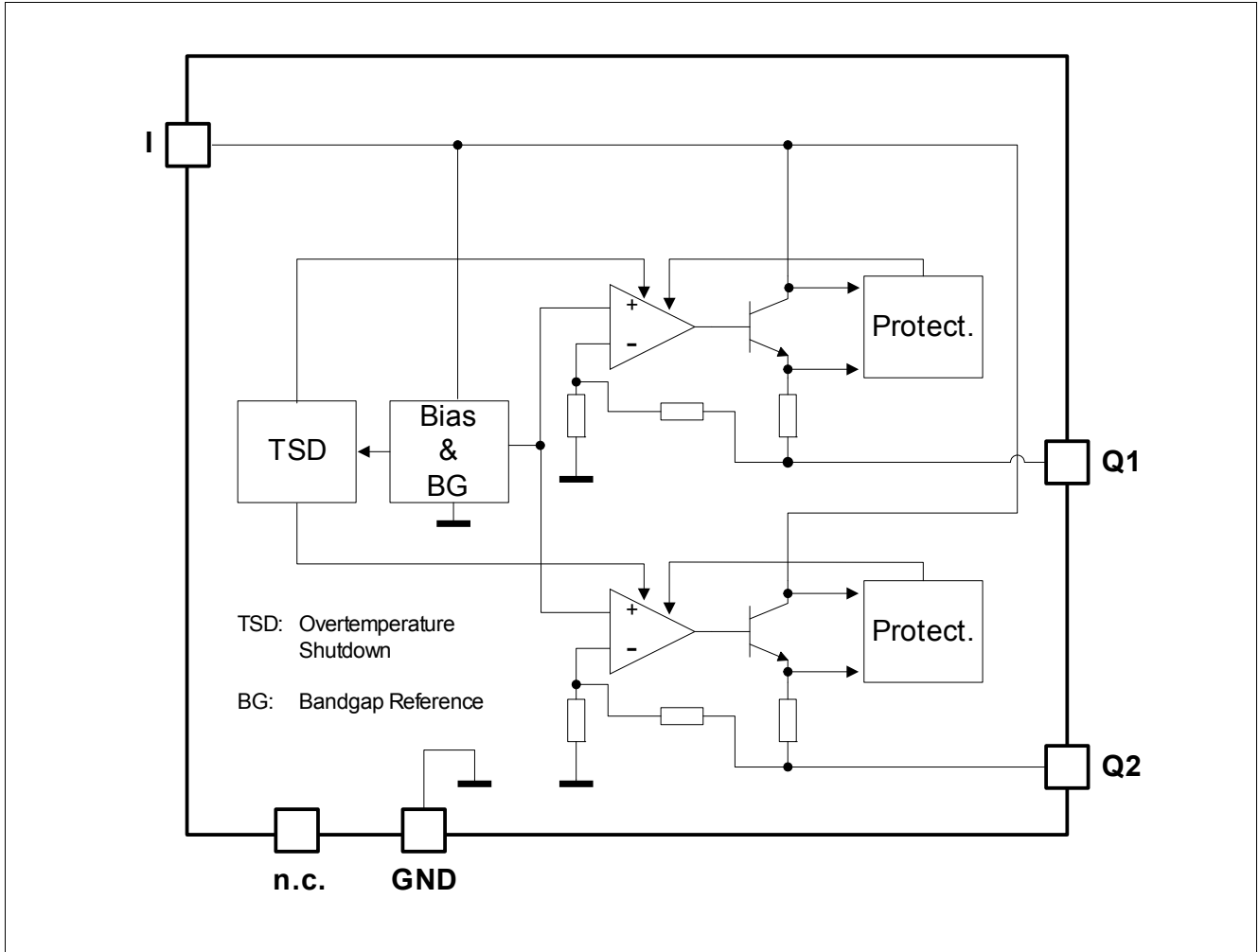

Figure 1 Block Diagram

3 Pin Configuration

3.1 Pin Assignment

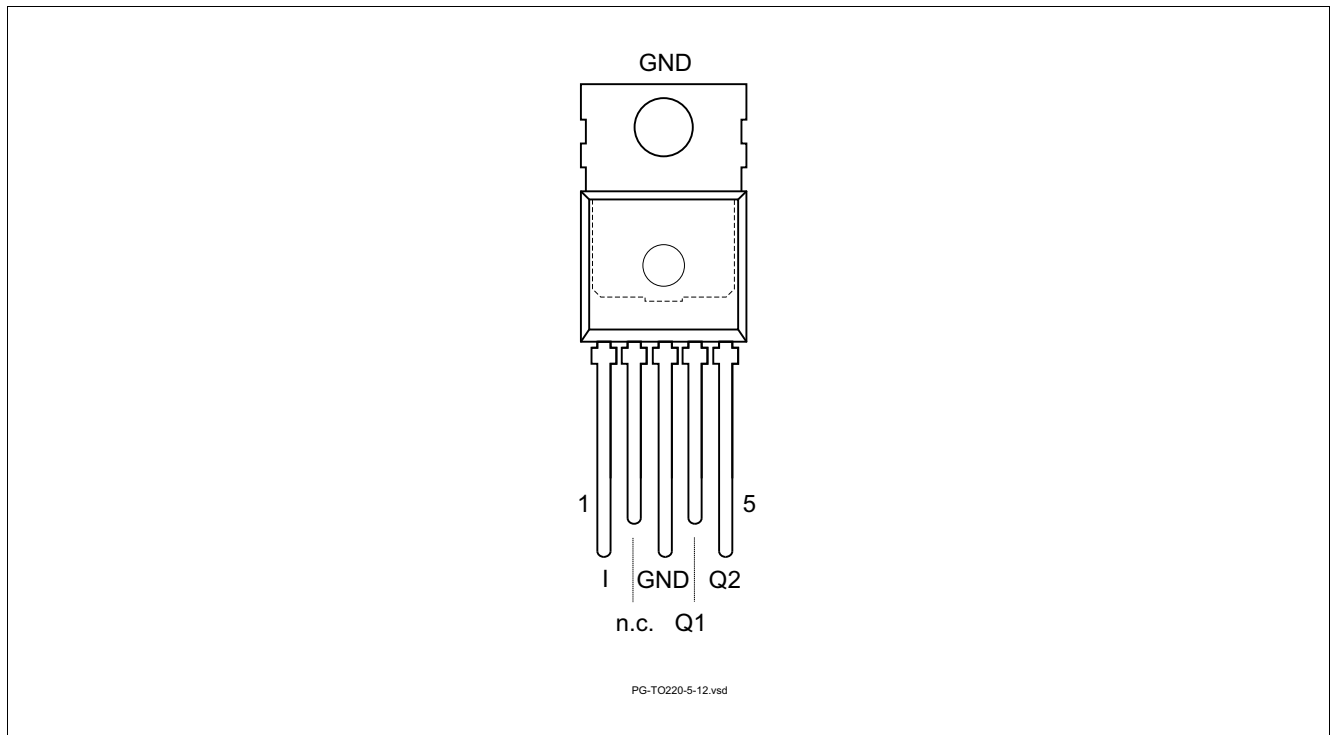

Figure 2 Pin Configuration

3.2 Pin Definitions and Functions

Pin	Symbol	Function
1	I	Input voltage block to ground directly at the IC with a ceramic capacitor.
2	n.c.	not connected leave open, don't connect
3	GND	Ground connect to tab (heat sink)
4	Q1	5V-Output voltage, e.g. for microcontroller and logic circuit block to ground with a capacitor respecting the values given in “Output Capacitor’s Requirements for Stability” on Page 7
5	Q2	15V-Output voltage, e.g. for MOS driver circuit block to ground with a capacitor as specified in “Output Capacitor’s Requirements for Stability” on Page 8
Tab	–	Tab connect to pin3 (GND) and heatsink area

4 General Product Characteristics

4.1 Absolute Maximum Ratings

Table 1 Absolute Maximum Ratings

$T_j = -40\text{ °C}$ to $+150\text{ °C}$; all voltages with respect to ground, positive current flowing into pin (unless otherwise specified)

Parameter	Symbol	Limit Values		Unit	Remarks
		Min.	Max.		
Input					
Voltage	V_I	-0.3	60	V	during max. 400ms see also Chapter 6
		-0.3	40	V	
Outputs Q1, Q2					
Voltage	V_{Q1}	-0.3	6.5	V	–
Voltage	V_{Q2}	-0.3	20	V	–
Temperatures					
Junction Temperature	T_j	-40	150	°C	–
Storage Temperature	T_{stg}	-50	150	°C	–
ESD-Protection					
All Pins	V_{ESD}	-2	2	kV	HBM ¹⁾
All Pins	V_{ESD}	-1	1	kV	CDM ²⁾

1) ESD susceptibility, HBM according to EIA/JESD 22-A114B

2) ESD susceptibility, Charged Device Model "CDM" EIA/JESD22-C101 or ESDA STM5.3.1

Note: Stresses above the ones listed here may cause permanent damage to the device. Exposure to absolute maximum rating conditions for extended periods may affect device reliability.

Note: Integrated protection functions are designed to prevent IC destruction under fault conditions described in the data sheet. Fault conditions are considered as "outside" normal operating range. Protection functions are not designed for continuous repetitive operation.

4.2 Operating Range

Table 2 Operating Range

Parameter	Symbol	Limit Values		Unit	Remarks
		Min.	Max.		
Input Voltage Range for Q1	V_{I1}	12	60	V	only Q1 functional; during max. 400ms ¹⁾
	V_{I1}	12	40	V	only Q1 functional ¹⁾
Input Voltage Range for Q2	V_{I2}	20	60	V	Q1 and Q2 functional; during max. 400ms ¹⁾
	V_{I2}	20	40	V	Q1 and Q2 functional ¹⁾
Junction temperature	T_j	-40	150	°C	–

1) also consider the specification of the Dropout Voltage V_{DRQ1} , V_{DRQ2} given in the [Table 4](#)

4.3 Thermal Resistances

Table 3 Thermal Resistances¹⁾

Parameter	Symbol	Typ. Limit Value	Unit	Remarks
Junction to Case	R_{thJC}	4.1	K/W	underlying P = 2W power dissipation with power zener activated ²⁾
Junction to Case	R_{thJC}	6.1	K/W	underlying P = 2W power dissipation with power zener deactivated ³⁾

1) not subject to production test, specified by design

2) for the taken case with the zener diode activated the power distribution on the chip is given as follows. Power zener: $P_{Zener} = 0.85W$; power stage Q1: $P_{PowerstageQ1} = 1.03W$; power stage Q2: $P_{PowerstageQ2} = 0.12W$

3) for the taken case with the zener diode deactivated the power distribution on the chip is given as follows. Power stage Q1 $P_{PowerstageQ1} = 1.72W$; power stage Q2 $P_{PowerstageQ2} = 0.28W$

Note: In the operating range, the functions given in the circuit description are fulfilled.

5 Electrical Characteristics

Table 4 Electrical Characteristics

$V_1 = 24\text{ V}$; $-40\text{ °C} < T_j < 150\text{ °C}$; all voltages with respect to ground; positive current defined flowing out of pin; unless otherwise specified.

Parameter	Symbol	Limit Values			Unit	Test Condition
		Min.	Typ.	Max.		
Current Consumption						
Quiescent Current $I_q = I_1 - (I_{Q1} + I_{Q2})$	I_q	–	700	1000	μA	$I_{Q1} = 1\text{ mA}$; $I_{Q2} = 1\text{ mA}$
Current Consumption $I_q = I_1 - (I_{Q1} + I_{Q2})$	I_q	–	1	3.5	mA	$I_{Q1} = 100\text{ mA}$; $I_{Q2} = 30\text{ mA}$
Output Q1 (5 V)						
Output Voltage	V_{Q1}	4.85	5.00	5.15	V	$I_{Q1} = 80\text{ mA}$; $T_j = 25\text{ °C}$
Output Voltage	V_{Q1}	4.75	–	5.25	V	$1\text{ mA} < I_{Q1} < 100\text{ mA}$
Output Current Limitation	I_{Q1}	101	180	600	mA	$V_{Q1, \text{nom}} - 100\text{mV}$; $V_1 = 24\text{V}$
Dropout Voltage $V_{\text{DRQ1}} = V_1 - V_{Q1}$	V_{DRQ1}	–	5	10	V	$I_{Q1} = 100\text{ mA}$; $I_{Q2} = 30\text{ mA}^{1)}$
Load Regulation (steady state)	ΔV_{Q1}	–	20	50	mV	$1\text{ mA} < I_{Q1} < 100\text{ mA}$; $V_1 = 24\text{ V}$
Line Regulation (steady state)	ΔV_{Q1}	–	15	50	mV	$I_{Q1} = 1\text{ mA}$; $24\text{ V} < V_1 < 40\text{ V}$
Power Supply Ripple Rejection ²⁾	$PSRR_{Q1}$	–	55	–	dB	$f_r = 100\text{ Hz}$; $V_r = 1\text{Vpp}$
Output Capacitor's Requirements for Stability	C_{Q1}	1.0	–	–	μF	– ²⁾³⁾
	$ESR(C_{Q1})$	–	–	5.0	Ω	– ²⁾

Table 4 Electrical Characteristics (cont'd)

$V_1 = 24\text{ V}$; $-40\text{ °C} < T_j < 150\text{ °C}$; all voltages with respect to ground; positive current defined flowing out of pin; unless otherwise specified.

Parameter	Symbol	Limit Values			Unit	Test Condition
		Min.	Typ.	Max.		
Output Q2 (15 V)						
Output Voltage	V_{Q2}	14.4	15.0	15.6	V	$I_{Q2} = 15\text{ mA}$; $T_j = 25\text{ °C}$
Output Voltage	V_{Q2}	14.25	–	15.75	V	$1\text{ mA} < I_{Q2} < 30\text{ mA}$
Output Current Limitation	I_{Q2}	31	100	220	mA	$V_{Q2, \text{nom}} - 100\text{mV}$; $V_1 = 24\text{V}$
Dropout Voltage $V_{\text{DRQ2}} = V_1 - V_{Q2}$	V_{DRQ2}	–	3	6	V	$I_{Q2} = 30\text{ mA}$; $I_{Q1} = 100\text{ mA}^{1)}$
Load Regulation	ΔV_{Q2}	–	50	150	mV	$1\text{ mA} < I_{Q2} < 30\text{ mA}$; $V_1 = 24\text{ V}$
Line Regulation	ΔV_{Q2}	–	30	150	mV	$I_{Q2} = 1\text{ mA}$; $24\text{ V} < V_1 < 40\text{ V}$
Power Supply Ripple Rejection ²⁾	$PSRR_{Q2}$	–	50	–	dB	$f_r = 100\text{ Hz}$; $V_r = 1\text{Vpp}$
Output Capacitor's Requirements for Stability	C_{Q2}	1.0	–	–	μF	– ²⁾³⁾
	$ESR(C_{Q2})$	–	–	5.0	Ω	– ²⁾

1) Drop voltage = $V_1 - V_Q$ (measured when the output voltage has dropped 100 mV from the nominal value).

2) not subject to production test, specified by design.

3) for further details please refer to [Chapter 6](#).

Note: The listed characteristics are ensured over the operating range of the integrated circuit. Typical characteristics specified mean values expected over the production spread. If not otherwise specified, typical characteristics apply at $T_A = 25\text{ °C}$ and the given supply voltage.

5.1 Typical Performance Characteristics

Output Voltage V_{Q1} versus Junction Temperature T_j

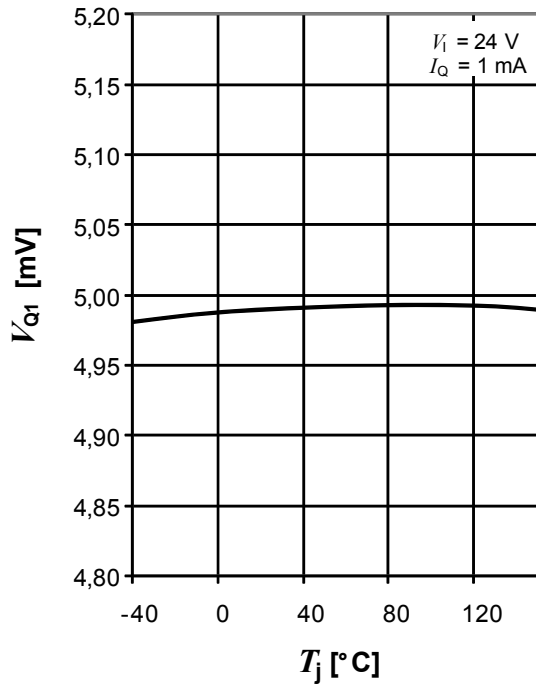

Output Voltage V_{Q2} versus Junction Temperature T_j

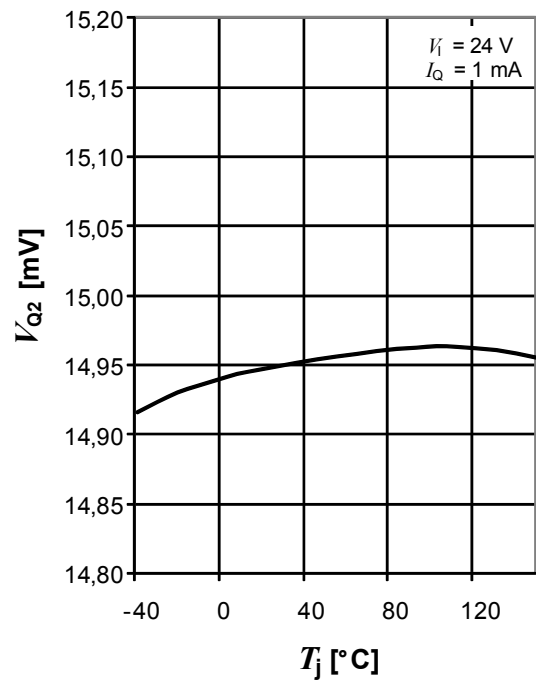

Output Current Limitation I_{Q1} versus Junction Temperature T_j (@ $V_{Q1,nom} - 100mV$)

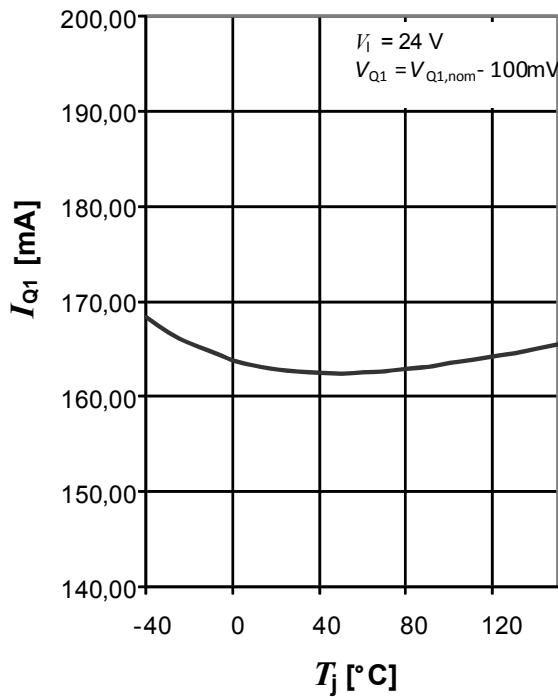

Output Current Limitation I_{Q2} versus Junction Temperature T_j (@ $V_{Q2,nom} - 100mV$)

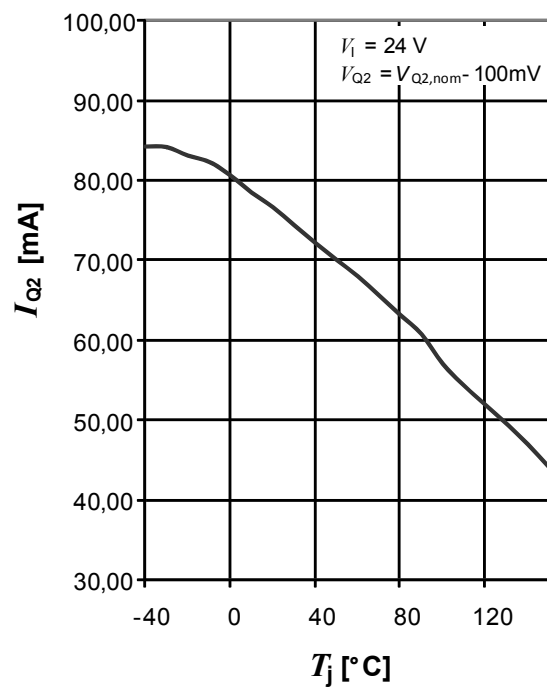

Line Regulation $\Delta V_{Q1,line}$ versus Input Voltage Change V_I

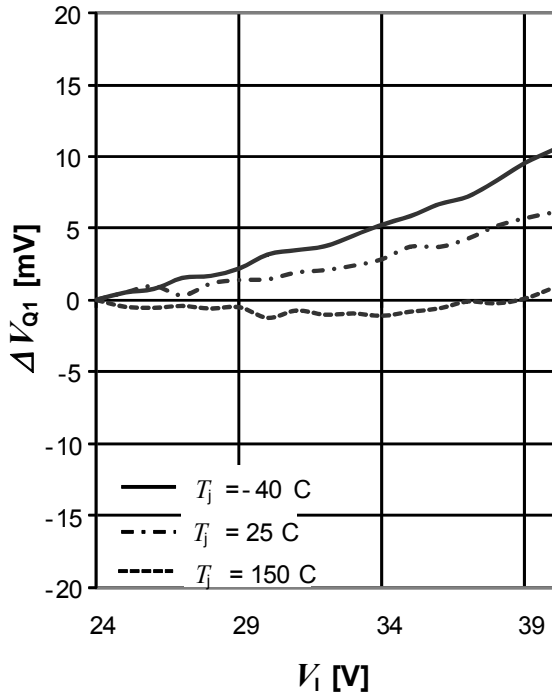

Line Regulation $\Delta V_{Q2,line}$ versus Input Voltage Change V_I

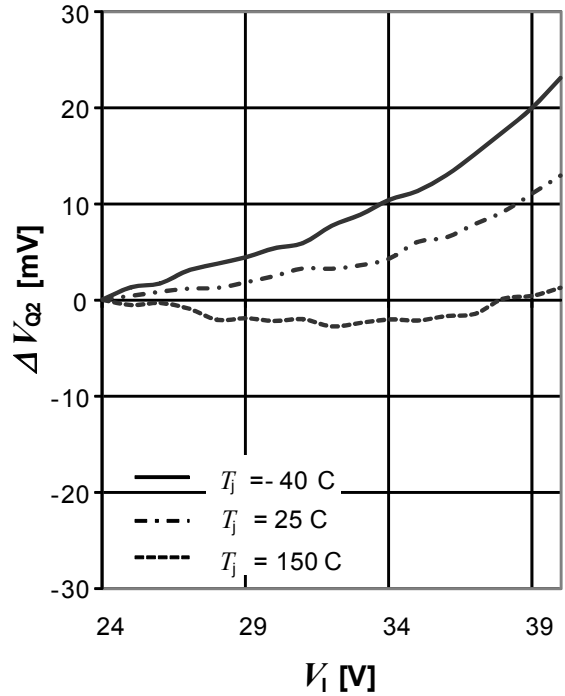

Load Regulation $\Delta V_{Q1,load}$ versus Output Current Change I_Q

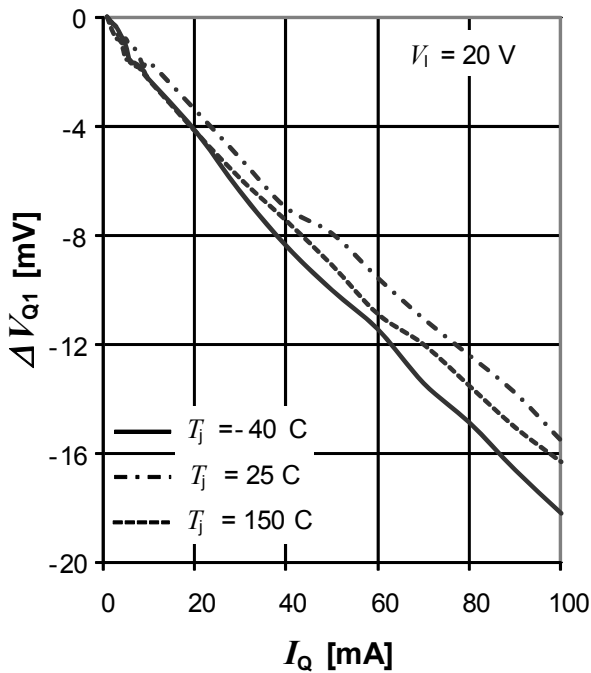

Load Regulation $\Delta V_{Q2,load}$ versus Output Current Change I_Q

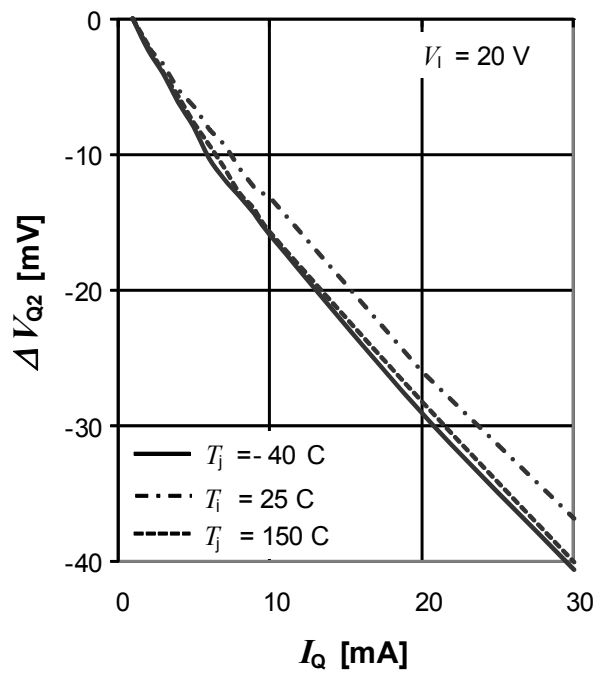

6 Application Information

Note: The following information is given as a hint for the implementation of the device only and shall not be regarded as a description or warranty of a certain functionality, condition or quality of the device.

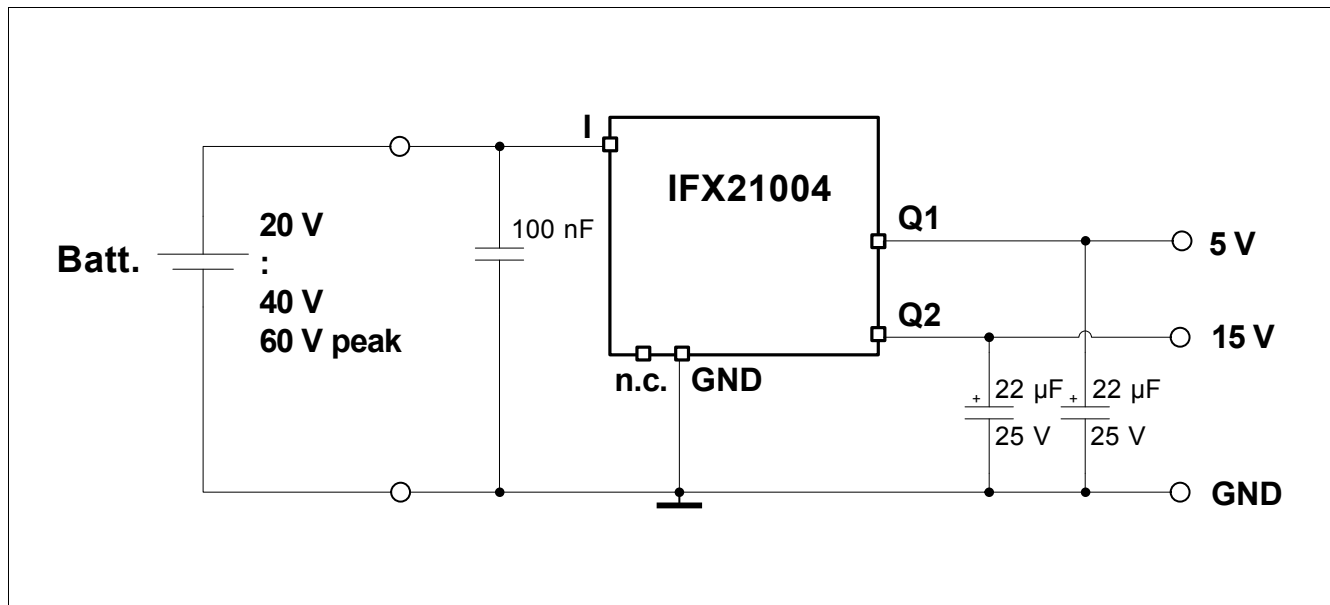

Figure 3 Application Circuit

Note: This is a very simplified example of an application circuit. The function must be verified in the real application.

The IFX21004TN V51 is operating from $20\text{ V} < V_1 < 40\text{ V}$ (60 V Peak) and can be directly connected to e.g. a battery line. The maximum output current of this regulator is controlled and limited internally; its output short circuit protection to ground is ensured up to V_1 -values of up to 24V.

When any high frequency disturbance is existing and should be filtered, an input capacitor in the range of 100 nF is helpful.

At both outputs Q1 and Q2 capacitors C_{Q1} and C_{Q2} are required in any case to maintain regulating stability. Therefore as minimum values the specification in [Table 4 “Electrical Characteristics” on Page 7](#) needs to be respected. In addition, to keep a good line transient regulation¹⁾ and load transient regulation²⁾, capacitor values of $C_{Q1} = C_{Q2} > 22\text{ }\mu\text{F}$ are recommended.

The IFX21004TN V51 is capable to withstand input voltages exceeding its nominal operating range up to values of 60 V during short time periods of up to 400ms. Such short input voltage pulses exceeding 40 V are absorbed by activating an internal zener diode structure. Please note in this context that, due to hysteresis, in some cases the zener diode may remain activated also after the pulse when the input voltage is afterwards around values of 40V. If in such cases the input voltage is lowered afterwards the power zener will be switched off again. During the switching of the zener diode the effects of potential switching noise needs to be considered as they may cause transients on the outputs Q1 and Q2. The occurrence of such transient output voltages is dependent on the application's load as well as the used output capacitors. Such potential output transients can be minimized by using larger values for C_{Q1} and C_{Q2} that will damp such output transients.

1) fast voltage transients at the regulator's input

2) fast current transients at the regulator's output

7 Package Outlines

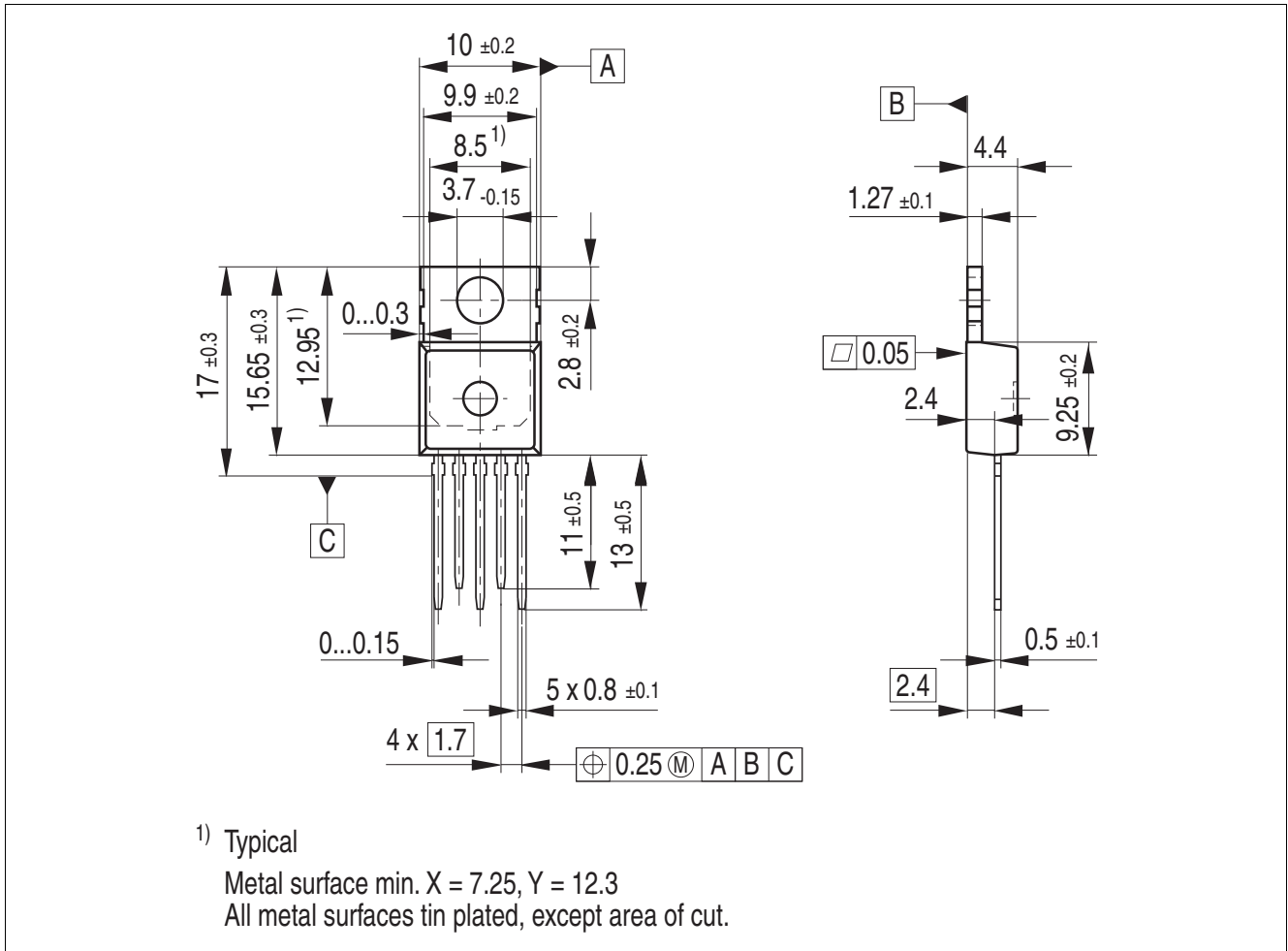

Figure 4 PG-TO220-5 (Plastic Small Outline Transistor)

Green Product (RoHS compliant)

To meet the world-wide customer requirements for environmentally friendly products and to be compliant with government regulations the device is available as a green product. Green products are RoHS-Compliant (i.e. Pb-free finish on leads and suitable for Pb-free soldering according to IPC/JEDEC J-STD-020).

8 Revision History

Revision	Date	Changes
1.00	2010-11-04	Data Sheet Initial Release

Edition 2010-11-04

**Published by
Infineon Technologies AG
81726 Munich, Germany**

**© 2010 Infineon Technologies AG
All Rights Reserved.**

Legal Disclaimer

The information given in this document shall in no event be regarded as a guarantee of conditions or characteristics. With respect to any examples or hints given herein, any typical values stated herein and/or any information regarding the application of the device, Infineon Technologies hereby disclaims any and all warranties and liabilities of any kind, including without limitation, warranties of non-infringement of intellectual property rights of any third party.

Information

For further information on technology, delivery terms and conditions and prices, please contact the nearest Infineon Technologies Office (www.infineon.com).

Warnings

Due to technical requirements, components may contain dangerous substances. For information on the types in question, please contact the nearest Infineon Technologies Office.

The Infineon Technologies component described in this Data Sheet may be used in life-support devices or systems and/or automotive, aviation and aerospace applications or systems only with the express written approval of Infineon Technologies, if a failure of such components can reasonably be expected to cause the failure of that life-support automotive, aviation and aerospace device or system or to affect the safety or effectiveness of that device or system. Life support devices or systems are intended to be implanted in the human body or to support and/or maintain and sustain and/or protect human life. If they fail, it is reasonable to assume that the health of the user or other persons may be endangered.



Компания «ЭлектроПласт» предлагает заключение долгосрочных отношений при поставках импортных электронных компонентов на взаимовыгодных условиях!

Наши преимущества:

- Оперативные поставки широкого спектра электронных компонентов отечественного и импортного производства напрямую от производителей и с крупнейших мировых складов;
- Поставка более 17-ти миллионов наименований электронных компонентов;
- Поставка сложных, дефицитных, либо снятых с производства позиций;
- Оперативные сроки поставки под заказ (от 5 рабочих дней);
- Экспресс доставка в любую точку России;
- Техническая поддержка проекта, помощь в подборе аналогов, поставка прототипов;
- Система менеджмента качества сертифицирована по Международному стандарту ISO 9001;
- Лицензия ФСБ на осуществление работ с использованием сведений, составляющих государственную тайну;
- Поставка специализированных компонентов (Xilinx, Altera, Analog Devices, Intersil, Interpoint, Microsemi, Aeroflex, Peregrine, Syfer, Eurofarad, Texas Instrument, Miteq, Cobham, E2V, MA-COM, Hittite, Mini-Circuits, General Dynamics и др.);

Помимо этого, одним из направлений компании «ЭлектроПласт» является направление «Источники питания». Мы предлагаем Вам помощь Конструкторского отдела:

- Подбор оптимального решения, техническое обоснование при выборе компонента;
- Подбор аналогов;
- Консультации по применению компонента;
- Поставка образцов и прототипов;
- Техническая поддержка проекта;
- Защита от снятия компонента с производства.



Как с нами связаться

Телефон: 8 (812) 309 58 32 (многоканальный)

Факс: 8 (812) 320-02-42

Электронная почта: org@eplast1.ru

Адрес: 198099, г. Санкт-Петербург, ул. Калинина, дом 2, корпус 4, литера А.