



# N-Channel Enhancement-Mode Vertical DMOS FET

## Features

- ▶ Low threshold (2.0V max.)
- ▶ High input impedance
- ▶ Low input capacitance (125pF max.)
- ▶ Fast switching speeds
- ▶ Low on-resistance
- ▶ Free from secondary breakdown
- ▶ Low input and output leakage
- ▶ Complementary N- and P-channel devices

## Applications

- ▶ Logic level interfaces - ideal for TTL and CMOS
- ▶ Solid state relays
- ▶ Battery operated systems
- ▶ Photo voltaic drives
- ▶ Analog switches
- ▶ General purpose line drivers
- ▶ Telecom switches

## General Description

This low threshold, enhancement-mode (normally-off) transistor utilizes a vertical DMOS structure and Supertex's well-proven, silicon-gate manufacturing process. This combination produces a device with the power handling capabilities of bipolar transistors and the high input impedance and positive temperature coefficient inherent in MOS devices. Characteristic of all MOS structures, this device is free from thermal runaway and thermally-induced secondary breakdown.

Supertex's vertical DMOS FETs are ideally suited to a wide range of switching and amplifying applications where very low threshold voltage, high breakdown voltage, high input impedance, low input capacitance, and fast switching speeds are desired.

## Ordering Information

Device	Package Options			BV <sub>DSS</sub> /BV <sub>DGS</sub> (V)	R <sub>DS(ON)</sub> (max) (Ω)	I <sub>D(ON)</sub> (min) (A)	V <sub>GS(th)</sub> (max) (V)
	TO-92	TO-243AA (SOT-89)	Die*				
TN2540	TN2540N3-G	TN2540N8-G	TN2540ND	400	12	1.0	2.0

-G indicates package is RoHS compliant ("Green")

\* MIL visual screening available



## Pin Configurations

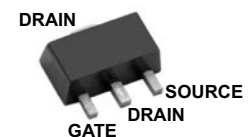
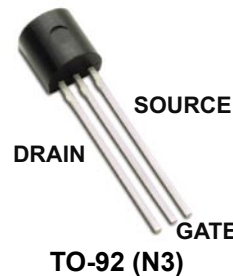

## Absolute Maximum Ratings

Parameter	Value
Drain-to-source voltage	BV <sub>DSS</sub>
Drain-to-gate voltage	BV <sub>DGS</sub>
Gate-to-source voltage	±20V
Operating and storage temperature	-55°C to +150°C
Soldering temperature*	300°C

Absolute Maximum Ratings are those values beyond which damage to the device may occur. Functional operation under these conditions is not implied. Continuous operation of the device at the absolute rating level may affect device reliability. All voltages are referenced to device ground.

\* Distance of 1.6mm from case for 10 seconds.

## Product Marking

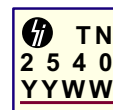

YY = Year Sealed  
 WW = Week Sealed  
 \_\_\_\_\_ = "Green" Packaging

**TO-92 (N3)**

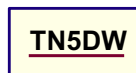

W = Code for week sealed  
 \_\_\_\_\_ = "Green" Packaging

**TO-243AA (SOT-89) (N8)**

### Thermal Characteristics

Package	I <sub>D</sub> (continuous) <sup>†</sup> (mA)	I <sub>D</sub> (pulsed) (A)	Power Dissipation @T <sub>A</sub> = 25°C (W)	θ <sub>jc</sub> (°C/W)	θ <sub>ja</sub> (°C/W)	I <sub>DR</sub> <sup>†</sup> (mA)	I <sub>DRM</sub> (A)
TO-92	175	2.0	0.74	125	170	175	2.0
TO-243AA (SOT-89)	260	1.8	1.6‡	15	78‡	260	1.8

**Notes:**

- † I<sub>D</sub> (continuous) is limited by max rated T<sub>j</sub>.
- ‡ Mounted on FR5 Board, 25mm x 25mm x 1.57mm.

### Electrical Characteristics (T<sub>A</sub> = 25°C unless otherwise specified)

Sym	Parameter	Min	Typ	Max	Units	Conditions
BV <sub>DSS</sub>	Drain-to-source breakdown voltage	400	-	-	V	V <sub>GS</sub> = 0V, I <sub>D</sub> = 100µA
V <sub>GS(th)</sub>	Gate threshold voltage	0.6	-	2.0	V	V <sub>GS</sub> = V <sub>DS</sub> , I <sub>D</sub> = 1.0mA
ΔV <sub>GS(th)</sub>	Change in V <sub>GS(th)</sub> with temperature	-	-2.5	-4.0	mV/°C	V <sub>GS</sub> = V <sub>DS</sub> , I <sub>D</sub> = 1.0mA
I <sub>GSS</sub>	Gate body leakage	-	-	100	nA	V <sub>GS</sub> = ± 20V, V <sub>DS</sub> = 0V
I <sub>DSS</sub>	Zero gate voltage drain current	-	-	10	µA	V <sub>GS</sub> = 0V, V <sub>DS</sub> = Max Rating
		-	-	1.0	mA	V <sub>DS</sub> = 0.8 Max Rating, V <sub>GS</sub> = 0V, T <sub>A</sub> = 125°C
I <sub>D(ON)</sub>	On-state drain current	0.3	0.5	-	A	V <sub>GS</sub> = 4.5V, V <sub>DS</sub> = 25V
		0.75	1.0	-		V <sub>GS</sub> = 10V, V <sub>DS</sub> = 25V
R <sub>DS(ON)</sub>	Static drain-to-source on-state resistance	-	8.0	12	Ω	V <sub>GS</sub> = 4.5V, I <sub>D</sub> = 150mA
		-	8.0	12		V <sub>GS</sub> = 10V, I <sub>D</sub> = 500mA
ΔR <sub>DS(ON)</sub>	Change in R <sub>DS(ON)</sub> with temperature	-	-	0.75	%/°C	V <sub>GS</sub> = 10V, I <sub>D</sub> = 500mA
G <sub>FS</sub>	Forward transductance	125	200	-	mmho	V <sub>DS</sub> = 25V, I <sub>D</sub> = 100mA
C <sub>ISS</sub>	Input capacitance	-	95	125	pF	V <sub>GS</sub> = 0V, V <sub>DS</sub> = 25V, f = 1.0MHz
C <sub>OSS</sub>	Common source output capacitance	-	20	70		
C <sub>RSS</sub>	Reverse transfer capacitance	-	10	25		
t <sub>d(ON)</sub>	Turn-on delay time	-	-	20	ns	V <sub>DD</sub> = 25V, I <sub>D</sub> = 1.0A, R <sub>GEN</sub> = 25Ω
t <sub>r</sub>	Rise time	-	-	15		
t <sub>d(OFF)</sub>	Turn-off delay time	-	-	25		
t <sub>f</sub>	Fall time	-	-	20		
V <sub>SD</sub>	Diode forward voltage drop	-	-	1.8	V	V <sub>GS</sub> = 0V, I <sub>SD</sub> = 200mA
t <sub>rr</sub>	Reverse recovery time	-	300	-	ns	V <sub>GS</sub> = 0V, I <sub>SD</sub> = 1.0A

**Notes:**

- All D.C. parameters 100% tested at 25°C unless otherwise stated. (Pulse test: 300µs pulse, 2% duty cycle.)
- All A.C. parameters sample tested.

### Switching Waveforms and Test Circuit

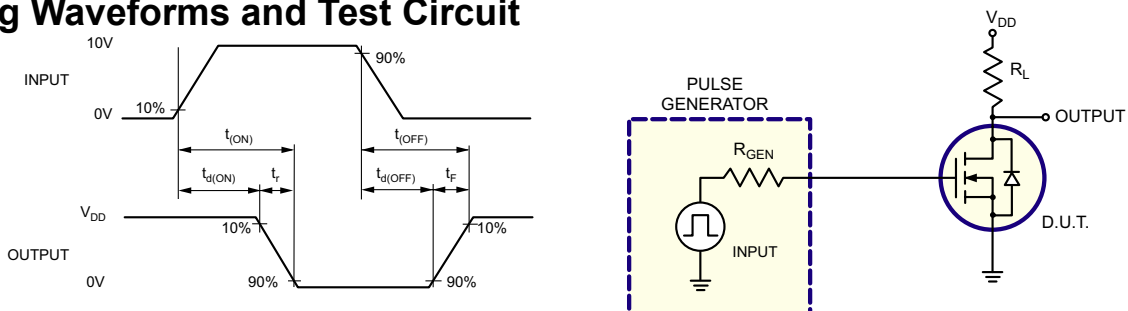

# Typical Performance Curves

Output Characteristics

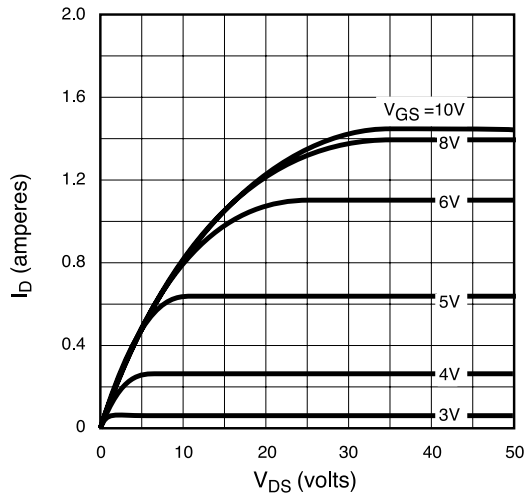

Saturation Characteristics

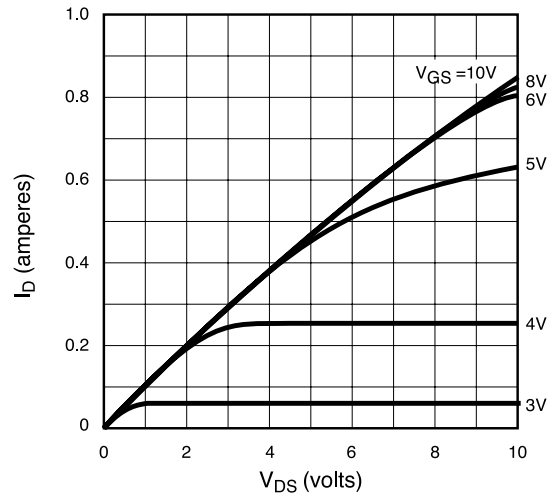

Transconductance vs. Drain Current

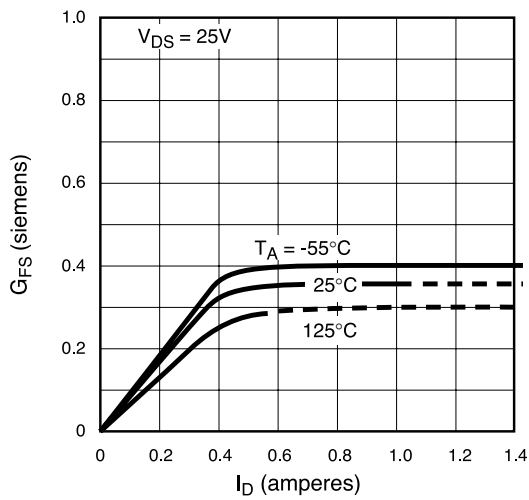

Power Dissipation vs. Ambient Temperature

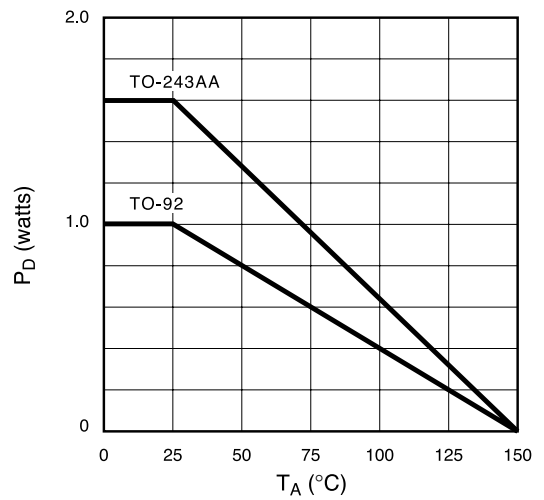

Maximum Rated Safe Operating Area

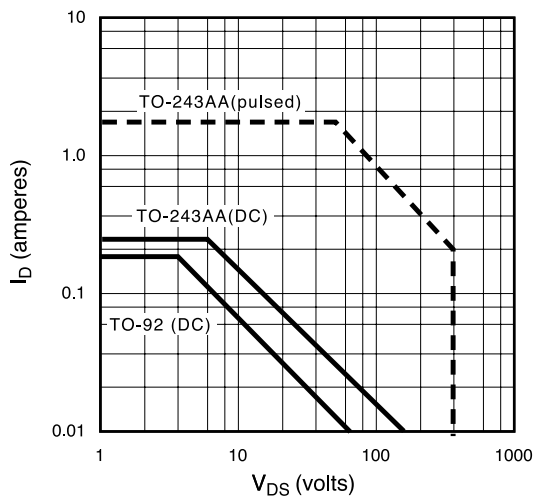

Thermal Response Characteristics

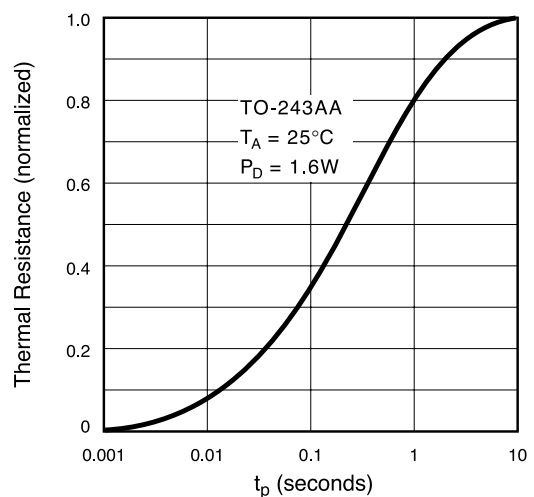

Typical Performance Curves (cont.)

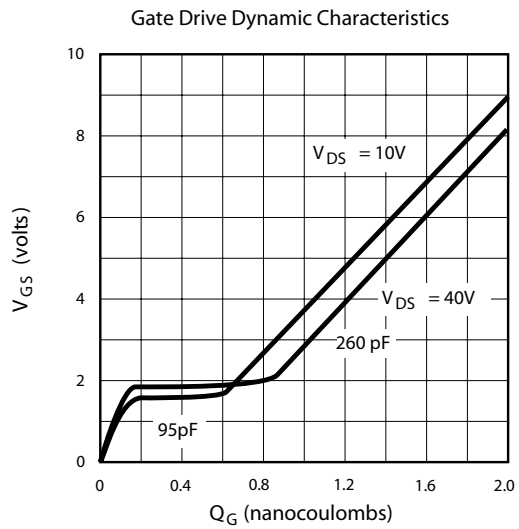
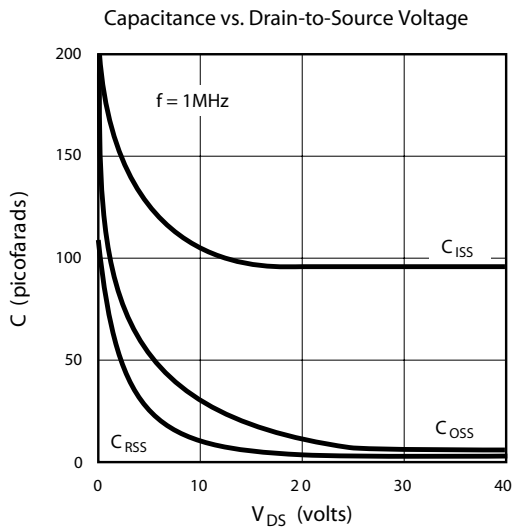
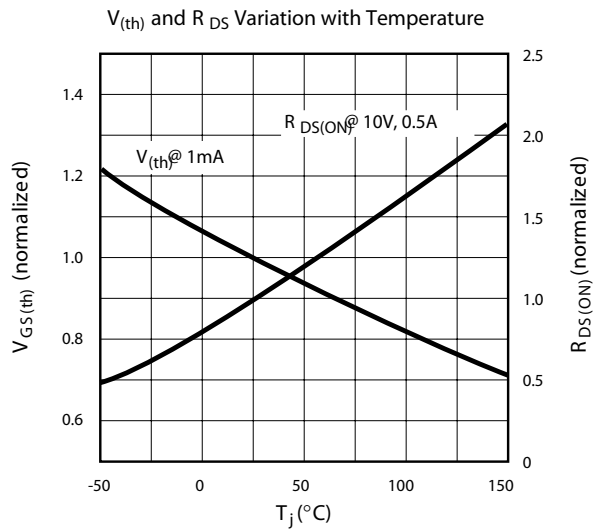
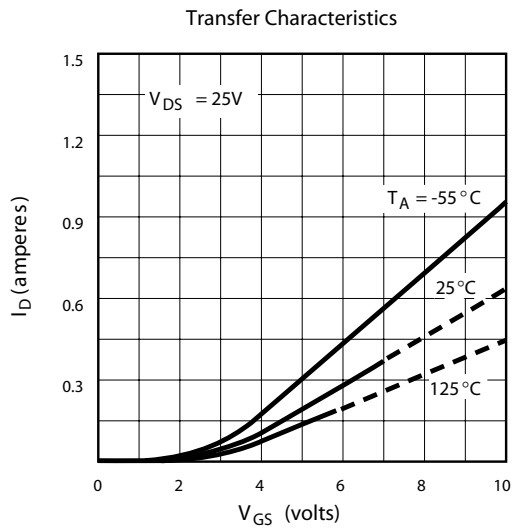
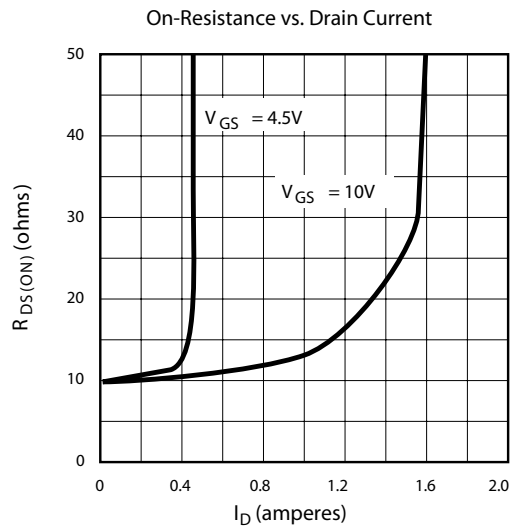
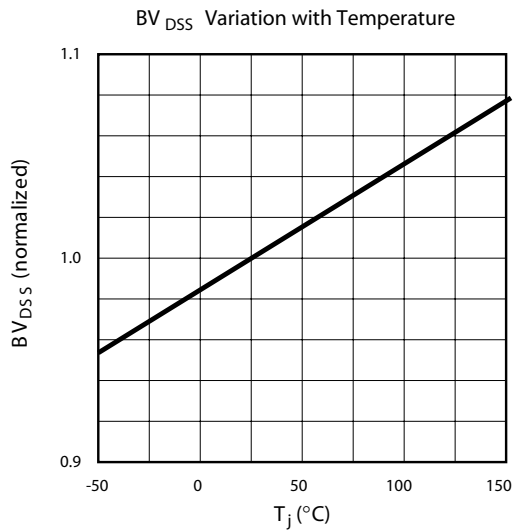

### 3-Lead TO-92 Package Outline (N3)

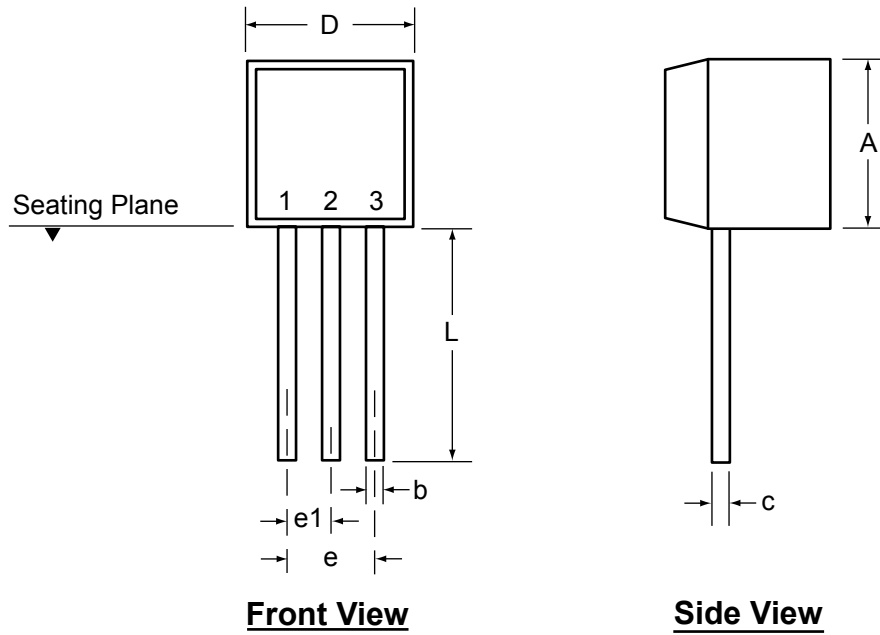

Symbol		A	b	c	D	E	E1	e	e1	L
Dimensions (inches)	MIN	.170	.014 <sup>†</sup>	.014 <sup>†</sup>	.175	.125	.080	.095	.045	.500
	NOM	-	-	-	-	-	-	-	-	-
	MAX	.210	.022 <sup>†</sup>	.022 <sup>†</sup>	.205	.165	.105	.105	.055	.610*

JEDEC Registration TO-92.

\* This dimension is not specified in the original JEDEC drawing. The value listed is for reference only.

† This dimension is a non-JEDEC dimension.

Drawings not to scale.

Supertex Doc.#: DSPD-3TO92N3, Version D080408.

### 3-Lead TO-243AA (SOT-89) Package Outline (N8)

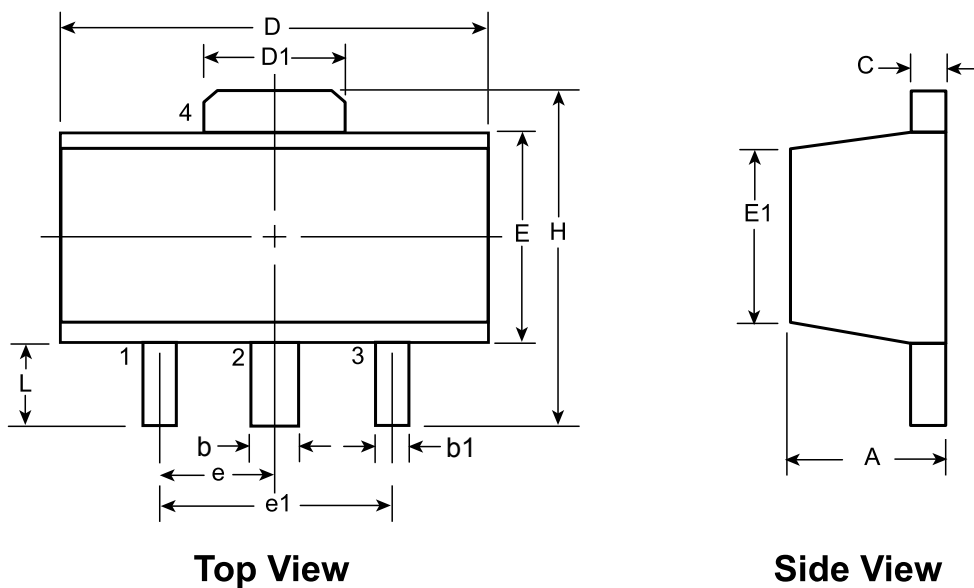

Symbol		A	b	b1	C	D	D1	E	E1	e	e1	H	L
Dimensions (mm)	MIN	1.40	0.44	0.36	0.35	4.40	1.62	2.29	2.13	1.50 BSC	3.00 BSC	3.94	0.89
	NOM	-	-	-	-	-	-	-	-			-	-
	MAX	1.60	0.56	0.48	0.44	4.60	1.83	2.60	2.29			4.25	1.20

JEDEC Registration TO-243, Variation AA, Issue C, July 1986.

Drawings not to scale.

Supertex Doc. #: DSPD-3TO243AAN8, Version D070908.

(The package drawing(s) in this data sheet may not reflect the most current specifications. For the latest package outline information go to <http://www.supertex.com/packaging.html>.)

Supertex inc. does not recommend the use of its products in life support applications, and will not knowingly sell them for use in such applications unless it receives an adequate "product liability indemnification insurance agreement." Supertex inc. does not assume responsibility for use of devices described, and limits its liability to the replacement of the devices determined defective due to workmanship. No responsibility is assumed for possible omissions and inaccuracies. Circuitry and specifications are subject to change without notice. For the latest product specifications refer to the Supertex inc. website: <http://www.supertex.com>.



Компания «ЭлектроПласт» предлагает заключение долгосрочных отношений при поставках импортных электронных компонентов на взаимовыгодных условиях!

Наши преимущества:

- Оперативные поставки широкого спектра электронных компонентов отечественного и импортного производства напрямую от производителей и с крупнейших мировых складов;
- Поставка более 17-ти миллионов наименований электронных компонентов;
- Поставка сложных, дефицитных, либо снятых с производства позиций;
- Оперативные сроки поставки под заказ (от 5 рабочих дней);
- Экспресс доставка в любую точку России;
- Техническая поддержка проекта, помощь в подборе аналогов, поставка прототипов;
- Система менеджмента качества сертифицирована по Международному стандарту ISO 9001;
- Лицензия ФСБ на осуществление работ с использованием сведений, составляющих государственную тайну;
- Поставка специализированных компонентов (Xilinx, Altera, Analog Devices, Intersil, Interpoint, Microsemi, Aeroflex, Peregrine, Syfer, Eurofarad, Texas Instrument, Miteq, Cobham, E2V, MA-COM, Hittite, Mini-Circuits, General Dynamics и др.);

Помимо этого, одним из направлений компании «ЭлектроПласт» является направление «Источники питания». Мы предлагаем Вам помощь Конструкторского отдела:

- Подбор оптимального решения, техническое обоснование при выборе компонента;
- Подбор аналогов;
- Консультации по применению компонента;
- Поставка образцов и прототипов;
- Техническая поддержка проекта;
- Защита от снятия компонента с производства.



#### Как с нами связаться

**Телефон:** 8 (812) 309 58 32 (многоканальный)

**Факс:** 8 (812) 320-02-42

**Электронная почта:** [org@eplast1.ru](mailto:org@eplast1.ru)

**Адрес:** 198099, г. Санкт-Петербург, ул. Калинина, дом 2, корпус 4, литера А.