

Digital Controller E5AK

CSM_E5AK_DS_E_3_1

Advanced Digital Controllers Ideal for Worldwide Use

- Modular structure
- High-accuracy: 100 ms sampling (for analog input)
- Auto-tuning and fuzzy self-tuning
- Conforms to international EMC and safety standards.
- IP66/NEMA4 (indoor use) front face
- Remote set point
- Serial communications (RS-232C, RS-422 and RS-485) and transfer output (4 to 20 mA)
- Position-proportional control model
- Heating/cooling control



Refer to *Safety Precautions for All Temperature Controllers*.

Refer to *E5AK Operation* for operating procedures.

Model Number Structure

■ Model Number Legend

E5AK- -500
 1 2

1. Model

- AA: Standard model
- PRR: Position-proportional model
- T: Programmable type

2. Number of alarms

- 2: Two alarms

Ordering Information

■ List of Models

Description	Model	Specification
Base Unit	E5AK-AA2 AC100-240	Standard model
	E5AK-AA2-500 AC100-240	Standard model with terminal cover
	E5AK-PRR2 AC100-240	Position-proportional model
	E5AK-PRR2-500 AC100-240	Position-proportional model with terminal cover
	E5AK-TAA2 AC100-240	Standard model
	E5AK-TAA2-500 AC100-240	Standard model with terminal cover
	E5AK-TPRR2 AC100-240	Position-proportional model
	E5AK-TPRR2-500 AC100-240	Position-proportional model with terminal cover

- Note:**
1. When using the heater burnout alarm function with a standard model, the Linear Output Unit cannot be used for the control outputs (heat).
 2. Be sure to specify the Current Transformer, Output Unit, and Option Unit when ordering.
 3. The Digital Controller provides transfer outputs at 4 to 20 mA for the PV and other values and control outputs at 4 to 20 mA for the current outputs.

Description	Model	Specification
Output Unit	E53-R	Relay
	E53-S	SSR
	E53-Q	Pulse (NPN) 12 VDC
	E53-Q3	Pulse (NPN) 24 VDC
	E53-Q4	Pulse (PNP) 24 VDC
	E53-C3	Linear (4 to 20 mA)
	E53-C3D	Linear (0 to 20 mA)
	E53-V34	Linear (0 to 10 V)
E53-V35	Linear (0 to 5 V)	

- Note:** The Digital Controller uses a dedicated, high-resolution Output Unit. The E53-C Current Output Unit for the E5□X cannot be used with the Digital Controller.

Description	Model	Specification
Option Unit	E53-AKB	Event input
	E53-EN01	Communication (RS-232C)
	E53-EN02	Communication (RS-422)
	E53-EN03	Communication (RS-485)
	E53-AKF	Transfer output

- Note:**
1. The Option Unit can be used either by the E5AK or E5EK.
 2. The E5AK allows a maximum of three Option Units to be mounted. Refer to page 8 for mounting combinations.
The E5EK allows only one Option Unit to be mounted.

Inspection Report

The Digital Controller can be provided together with an inspection report.

Refer to the following legend with the suffix "K" when ordering a model provided together with an inspection report.

E5□K-AA2-K, E5□K-PRR2-K, E5□K-TAA2-K, E5□K-TPRR2-K, E53-AKF-K

■ Accessories (Order Separately)

Name	Model	Hole diameter
Current Transformer	E54-CT1	5.8 mm
	E54-CT3	12.0 mm

Note: No CT is required unless the heater burnout alarm function is used.

Name	Model	Connectable models
Terminal Cover	E53-COV0809	E5AK

Note: The E53-COV0809 comes in a set with the two types of Terminal Covers listed on page 8.

Unit Label

Model	Y92S-L1
-------	---------

Mounting Bracket

Model	Y92H-5
-------	--------

Note: This mounting bracket set is included with the Temperature Controller. The set includes one bracket for the top and one for the bottom.

Waterproof Packing

Model
Y92S-P4

The Waterproof Packing is provided with the Digital Controller.

Specifications

■ Ratings

Item	100 to 240 VAC type
Supply voltage	100 to 240 VAC, 50/60 Hz
Power consumption	E5AK: 16 VA
Operating voltage range	85% to 110% of rated supply voltage
Input	Thermocouple: K, J, T, E, L, U, N, R, S, B, W, PLII Platinum resistance thermometer: JPt100, Pt100 Current input: 4 to 20 mA, 0 to 20 mA Voltage input: 1 to 5 V, 0 to 5 V, 0 to 10 V
Input impedance	Current input: 150 Ω; Voltage input: 1 MΩ min.
Control output	<u>Standard Model, Programmable Model</u> According to Output Unit (see <i>Output Unit Ratings and Characteristics</i>) <u>Position-proportional Model</u> 2 Relay outputs: SPST-NO, 1 A at 250 VAC (including inrush current) *1
Auxiliary output	SPST-NO, 3 A at 250 VAC (resistive load)
Control method *2	ON/OFF or 2-PID control (with auto-tuning)
Setting method	Digital setting using front panel keys
Indication method	7-segment digital display and LEDs
Potentiometer	100 Ω to 2.5 kΩ
Event input	Contact input: ON: 1 kΩ max., OFF: 100 kΩ min. No-contact input: ON: residual voltage: 1.5 V max., OFF: leakage current: 0.1 mA max.
Transfer output	4 to 20 mA, permissible load impedance: 600 Ω max., resolution: approx. 2,600
Remote SP input	Current input: 4 to 20 mA (Input impedance: 150 Ω)
Current Transformer input	Connect an exclusive Current Transformer (E54-CT1 or E54-CT3)
Other functions	<u>Standard</u> Manual output, heating/cooling control, SP limiter, loop burnout alarm, SP ramp, MV limiter, MV change rate limiter, input digital filter, input shift, run/stop, protect functions, scaling function. <u>Option</u> Multiple SP, run/stop selection, transfer output functions
Degree of protection	Conforms to IEC IP66 and NEMA4 (Indoor use)

Note: Do not use the output from an inverter as the power supply. Refer to *Safety Precautions for All Temperature Controllers*.

*1.All control outputs are isolated electrically from the input circuits.

*2.The E5AK-T/-TP do not support fuzzy self-tuning.

■ Input Ranges

Platinum Resistance Thermometer

Input (switch selectable)		JPt100	Pt100
Range	°C	-199.9 to 650.0	-199.9 to 650.0
	°F	-199.9 to 999.9	-199.9 to 999.9
Setting		0	1

Thermocouple

Input (switch selectable) (See note.)		K1	K2	J1	J2	T	E	L1	L2	U	N	R	S	B	W	PLII
Range	°C	-200 to 1,300	0.0 to 500.0	-100 to 850	0.0 to 400.0	-199.9 to 400.0	0 to 600	-100 to 850	0.0 to 400.0	-199.9 to 400.0	-200 to 1,300	0 to 1,700	0 to 1,700	100 to 1,800	0 to 2,300	0 to 1,300
	°F	-300 to 2,300	0.0 to 900.0	-100 to 1,500	0.0 to 750.0	-199.9 to 700.0	0 to 1,100	-100 to 1,500	0.0 to 750.0	-199.9 to 700.0	-300 to 2,300	0 to 3,000	0 to 3,000	300 to 3,200	0 to 4,100	0 to 2,300
Setting		2	3	4	5	6	7	8	9	10	11	12	13	14	15	16

Note: Setting number is factory-set to 2 (K1).
Thermocouple W is W/Re5-26 (tungsten rhenium 5, tungsten rhenium 26).

Current/Voltage

Input (switch selectable)	Current input		Voltage input		
	4 to 20 mA	0 to 20 mA	1 to 5 V	0 to 5 V	0 to 10 V
Range	One of following ranges depending on results of scaling -1999 to 9999 -199.9 to 999.9 -19.99 to 99.99 -1.999 to 9.999				
Setting	17	18	19	20	21

■ Characteristics

Indication accuracy (See note 1.)	Thermocouple: (±0.3% of indication value or ±1°C, whichever greater) ±1 digit max. Platinum resistance thermometer: (±0.2% of indication value or ±0.8°C, whichever greater) ±1 digit max. Analog input: ±0.2% FS ±1 digit max.
Hysteresis	0.01% to 99.99% FS (in units of 0.01% FS)
Proportional band (P)	0.1% to 999.9% FS (in units of 0.1% FS)
Integral (reset) time (I)	0 to 3,999 s (in units of 1 s)
Derivative (rate) time (D)	0 to 3,999 s (in units of 1 s)
Control period	1 to 99 s (in units of 1 s)
Manual reset value	0.0% to 100.0% (in units of 0.1%)
Alarm setting range	-1,999 to 9,999 or -199.9 or 999.9 (decimal point position dependent on input type or result of scaling)
Set time (See note 2.)	0 to 99 hrs 59 min or 0 to 99 min 59 s
Program capacity (See note 2.)	8 patterns, 16 steps
Programming method (See note 2.)	Time or ramp setting method
Time accuracy (See note 2.)	±0.2% (±500 ms) of the set value
Sampling period (See note 3.)	Temperature input: 250 ms Current/voltage input: 100 ms
Insulation resistance	20 MΩ min. (at 500 VDC)
Dielectric strength	2,000 VAC, 50/60 Hz for 1 min between terminals of different polarities
Vibration resistance	Malfunction: 10 to 55 Hz, 10 m/s ² (approx. 1G) for 10 min each in X, Y, and Z directions Destruction: 10 to 55 Hz, 20 m/s ² (approx. 2G) for 2 hrs each in X, Y, and Z directions
Shock resistance	Malfunction: 200 m/s ² min. (approx. 20G), 3 times each in 6 directions (100 m/s ² (approx. 10G) applied to the relay) Destruction: 300 m/s ² min. (approx. 30G), 3 times each in 6 directions
Ambient temperature	Operating: -10°C to 55°C (with no icing)/3-year warranty period: -10°C to 50°C Storage: -25°C to 65°C (with no icing)
Ambient humidity	Operating: 35% to 85%
Degree of protection	Front panel: NEMA4 for indoor use (equivalent to IP66) Rear case: IEC standard IP20 Terminals: IEC standard IP00
Memory protection	Non-volatile memory (number of writings: 100,000 operations)
Weight	E5AK: approx. 450 g E5EK: approx. 320 g Mounting bracket: approx. 65 g
EMC	Emission Enclosure: EN55011 Group 1 class A Emission AC Mains: EN55011 Group 1 class A Immunity ESD: EN61000-4-2: 4 kV contact discharge (level 2) 8 kV air discharge (level 3) Immunity RF-interference: ENV50140: 10 V/m (amplitude modulated, 80 MHz to 1 GHz) (level 3) 10 V/m (pulse modulated, 900 MHz) Immunity Conducted Disturbance: ENV50141: 10 V (0.15 to 80 MHz) (level 3) Immunity Burst: EN61000-4-4: 2 kV power-line (level 3) 2 kV I/O signal-line (level 4)
Approved standards	UL61010C-1, CSA 22.2 No. 61010-1 Conforms to EN61326-1: 2006, EN61010-1 (IEC61010-1) Conforms to VDE0106/part 100 (Finger Protection), when the separately-ordered terminal cover is mounted.

- Note: 1.** The indication accuracy of the K1, T, and N thermocouples at a temperature of -100°C or less is ±2°C ±1 digit maximum. The indication accuracy of the U, L1, and L2 thermocouples at any temperature is ±2°C ±1 digit maximum.
The indication accuracy of the B thermocouple at a temperature of 400°C or less is unrestricted.
The indication accuracy of the R and S thermocouples at a temperature of 200°C or less is ±3°C ±1 digit maximum.
The indication accuracy of the W thermocouple at any temperature is (±0.3% of the indicated value or ±3°C, whichever is greater) ±1 digit maximum.
The indication accuracy of the PLII thermocouple at any temperature is (±0.3% or ±2°C, whichever is greater) ±1 digit maximum.
- 2.** For Programmable Models.
- 3.** The sampling period of the standard model with CT and remote SP inputs is 250 ms.

■ Output Unit Ratings and Characteristics

Model		Specifications
E53-R	Relay output	5 A at 250 VAC (resistive load)
E53-S	SSR output	1 A at 75 to 250 VAC (resistive load)
E53-Q	Voltage output	NPN: 40 mA at 12 VDC (with short-circuit protection)
E53-Q3		NPN: 20 mA at 24 VDC (with short-circuit protection)
E53-Q4		PNP: 20 mA at 24 VDC (with short-circuit protection)
E53-C3	Linear current output	4 to 20 mA, permissible load impedance: 600 Ω max., resolution: approx. 2,600
E53-C3D		0 to 20 mA, permissible load impedance: 600 Ω max., resolution: approx. 2,600
E53-V34	Linear voltage output	0 to 10 VDC, permissible load impedance: 1 kΩ min., resolution: approx. 2,600
E53-V35		0 to 5 VDC, permissible load impedance: 1 kΩ min., resolution: approx. 2,600

Note: An output relay (1 A at 250 VAC) is mounted on the position-proportional model. (When replacing, use the E53-R.)

■ Option Unit Ratings and Characteristics

Model		Specifications
E53-AKB	Event input	Contact input: ON: 1 kΩ max., OFF: 100 kΩ min. No-contact input: ON: residual voltage 1.5 V max., OFF: leakage current 0.1 mA max.
E53-EN01	Communications	RS-232C Transmission method: Half-duplex
E53-EN02		RS-422 Synchronization method: Start-stop synchronization (asynchronous method)
E53-EN03		RS-485 Baud rate: 1.2/2.4/4.8/9.6/19.2 kbps Transmission code: ASCII
E53-AKF	Transfer output	4 to 20 mA: Permissible load impedance: 600 Ω max. Resolution: approx. 2,600

Note: Event input is used for switching the target value, run or stop command, or automatic and manual mode with an external signal input.

■ Current Transformer Ratings

Dielectric strength	1,000 VAC (for 1 min)
Vibration resistance	50 Hz, 98 m/s ² (10G)
Weight	E54-CT1: approx. 11.5 g; E54-CT3: approx. 50 g
Accessories (E54-CT3 only)	Armature: 2; Plug: 2

■ Heater Burnout Alarm

Max. heater current	Single-phase 50 A VAC (See note 1.)
Heater current value display accuracy	±5% FS±1 digit max.
Heater burnout alarm setting range	0.1 to 49.9 A (in units of 0.1 A) (See note 2.)
Min. detection ON time	190 ms (See note 3.)

Note: 1. Use the K2CU-F□□A-□GS (with gate input terminals) for the detection of three-phase heater burnout.

2. The heater burnout alarm is always OFF if the alarm is set to 0.0 A and always ON if the alarm is set to 50.0 A.

3. No heater burnout detection or heater current value measurement is possible if the control output (heat) is ON for less than 190 ms.

Nomenclature

E5AK

Operation Indicators

- **OUT1**
Lights when the pulse output function assigned to control output 1 turns ON.
- **OUT2**
Lights when the pulse output function assigned to control output 2 turns ON.
- **SUB1**
Lights when the output function assigned to auxiliary output 1 turns ON.
- **SUB2**
Lights when the output function assigned to auxiliary output 2 turns ON.
- **MANU**
Lights when the manual operation mode.
- **STOP**
Lights during operation has stopped.
- **RMT**
Lights during remote operation.
- **AT**
Flashes during auto-tuning.
- **RSP**
Lights during remote SP operation.
- **Bar Graph**
On a standard model (E5AK-AA2), this bar graph indicates the manipulated variable (heat) in 10% increments per single segment. On a position-proportional model (E5AK-PRR2), this bar graph indicates the valve opening in 10% increments per single segment.

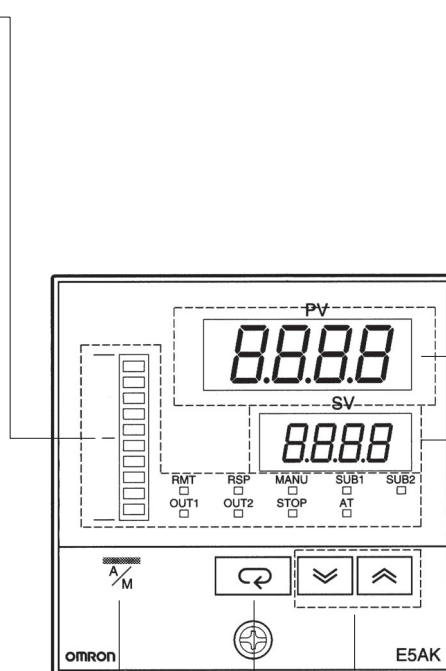

No. 1 Display

Displays the process value or parameter symbols.

No. 2 Display

Displays the set point, manipulated variable, or parameter settings.

Up Key/Down Key

Press to increase or decrease the value on the No.2 display.

Display Key

Press for less than 1 s to shift the display to the next parameter. When this key is pressed for 1 s or more, the menu screen will be displayed in any case.

A/M Key

Press to select the auto operation or manual operation.

Dimensions

Note: All units are in millimeters unless otherwise indicated.

E5AK

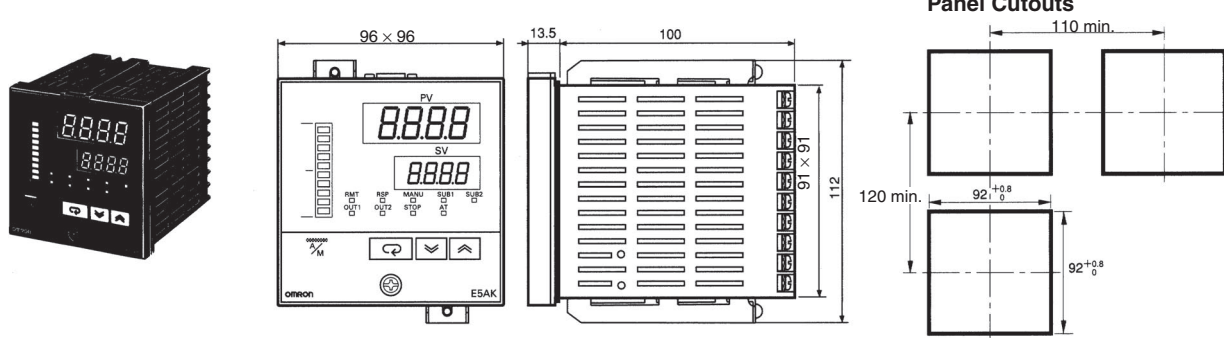

- Note:
1. Recommended panel thickness is 1 to 8 mm.
 2. Maintain the specified vertical and horizontal mounting space between each Unit. Units must not be closely mounted vertically or horizontally.

Accessories (Order Separately)

Terminal Cover

E53-COV0809

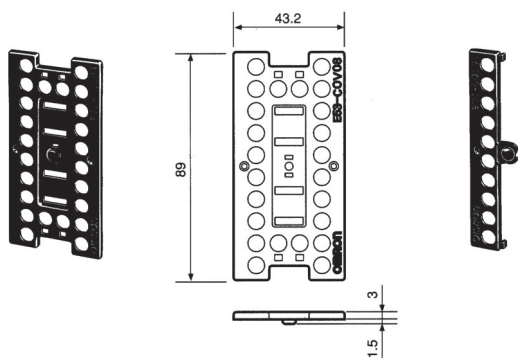

E53-COV08

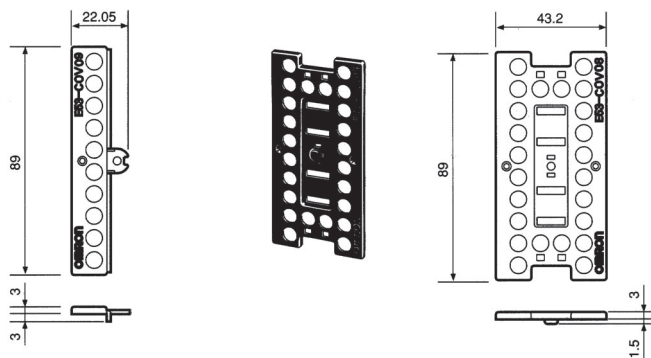

Current Transformer

E54-CT1

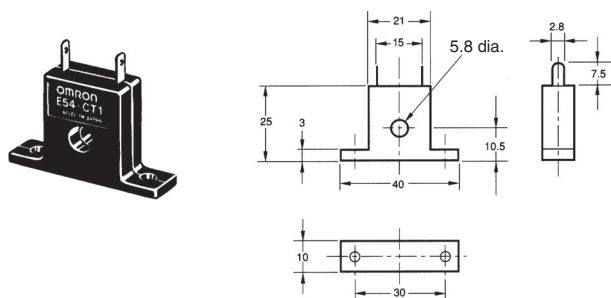

E54-CT3

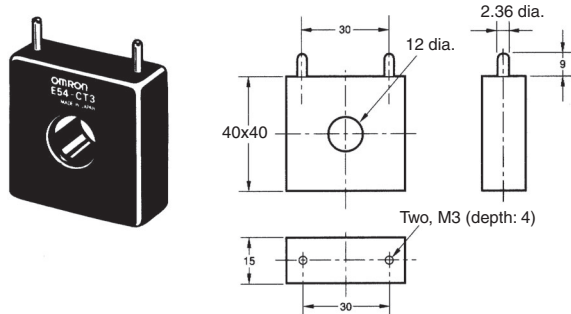

Unit Label (Order Separately)

Y92S-L1

UNIT LABEL														
mV	V	mA	A	kW										
mm	cm	m	km	g										
kg	m ³	ℓ	°C	°F										
K	%RH	%	ℓ/s	ℓ/min										
ℓ/h	m ³ /s	m ³ /min	m ³ /h	kg/h										
rpm	ppm	pH	kPa	mmHg										
mmH ₂ O	mH ₂ O	bar	Torr	mmAq										
kgf/cm ²	g/cm ²	kg/cm ²	kgf/cm ² G	kgf/cm ² G										
<table border="1"> <tr> <td></td> <td></td> <td></td> <td></td> <td></td> </tr> <tr> <td colspan="2">TAG No.</td> <td colspan="3">TAG No.</td> </tr> </table>										TAG No.		TAG No.		
TAG No.		TAG No.												

Waterproof Packing

Y92S-P4 (for DIN 96 × 96)

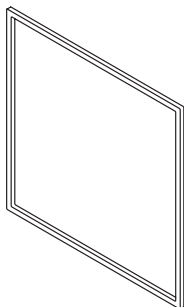

Order the Waterproof Packing separately if it becomes lost or damaged. (Refer to page 3.)

The Waterproof Packing can be used to achieve an IP66 degree of protection.

(Deterioration, shrinking, or hardening of the waterproof packing may occur depending on the operating environment. Therefore, periodic replacement is recommended to ensure the level of waterproofing specified in IP66. The time for periodic replacement depends on the operating environment. Be sure to confirm this point at your site. Consider one year a rough standard. OMRON shall not be liable for the level of water resistance if the customer does not perform periodic replacement.)

The Waterproof Packing does not need to be attached if a waterproof structure is not required.

ALL DIMENSIONS SHOWN ARE IN MILLIMETERS.

To convert millimeters into inches, multiply by 0.03937. To convert grams into ounces, multiply by 0.03527.

In the interest of product improvement, specifications are subject to change without notice.

Read and Understand This Catalog

Please read and understand this catalog before purchasing the products. Please consult your OMRON representative if you have any questions or comments.

Warranty and Limitations of Liability

WARRANTY

OMRON's exclusive warranty is that the products are free from defects in materials and workmanship for a period of one year (or other period if specified) from date of sale by OMRON.

OMRON MAKES NO WARRANTY OR REPRESENTATION, EXPRESS OR IMPLIED, REGARDING NON-INFRINGEMENT, MERCHANTABILITY, OR FITNESS FOR PARTICULAR PURPOSE OF THE PRODUCTS. ANY BUYER OR USER ACKNOWLEDGES THAT THE BUYER OR USER ALONE HAS DETERMINED THAT THE PRODUCTS WILL SUITABLY MEET THE REQUIREMENTS OF THEIR INTENDED USE. OMRON DISCLAIMS ALL OTHER WARRANTIES, EXPRESS OR IMPLIED.

LIMITATIONS OF LIABILITY

OMRON SHALL NOT BE RESPONSIBLE FOR SPECIAL, INDIRECT, OR CONSEQUENTIAL DAMAGES, LOSS OF PROFITS OR COMMERCIAL LOSS IN ANY WAY CONNECTED WITH THE PRODUCTS, WHETHER SUCH CLAIM IS BASED ON CONTRACT, WARRANTY, NEGLIGENCE, OR STRICT LIABILITY.

In no event shall the responsibility of OMRON for any act exceed the individual price of the product on which liability is asserted.

IN NO EVENT SHALL OMRON BE RESPONSIBLE FOR WARRANTY, REPAIR, OR OTHER CLAIMS REGARDING THE PRODUCTS UNLESS OMRON'S ANALYSIS CONFIRMS THAT THE PRODUCTS WERE PROPERLY HANDLED, STORED, INSTALLED, AND MAINTAINED AND NOT SUBJECT TO CONTAMINATION, ABUSE, MISUSE, OR INAPPROPRIATE MODIFICATION OR REPAIR.

Application Considerations

SUITABILITY FOR USE

OMRON shall not be responsible for conformity with any standards, codes, or regulations that apply to the combination of products in the customer's application or use of the products.

At the customer's request, OMRON will provide applicable third party certification documents identifying ratings and limitations of use that apply to the products. This information by itself is not sufficient for a complete determination of the suitability of the products in combination with the end product, machine, system, or other application or use.

The following are some examples of applications for which particular attention must be given. This is not intended to be an exhaustive list of all possible uses of the products, nor is it intended to imply that the uses listed may be suitable for the products:

- Outdoor use, uses involving potential chemical contamination or electrical interference, or conditions or uses not described in this catalog.
- Nuclear energy control systems, combustion systems, railroad systems, aviation systems, medical equipment, amusement machines, vehicles, safety equipment, and installations subject to separate industry or government regulations.
- Systems, machines, and equipment that could present a risk to life or property.

Please know and observe all prohibitions of use applicable to the products.

NEVER USE THE PRODUCTS FOR AN APPLICATION INVOLVING SERIOUS RISK TO LIFE OR PROPERTY WITHOUT ENSURING THAT THE SYSTEM AS A WHOLE HAS BEEN DESIGNED TO ADDRESS THE RISKS, AND THAT THE OMRON PRODUCTS ARE PROPERLY RATED AND INSTALLED FOR THE INTENDED USE WITHIN THE OVERALL EQUIPMENT OR SYSTEM.

PROGRAMMABLE PRODUCTS

OMRON shall not be responsible for the user's programming of a programmable product, or any consequence thereof.

Disclaimers

CHANGE IN SPECIFICATIONS

Product specifications and accessories may be changed at any time based on improvements and other reasons.

It is our practice to change model numbers when published ratings or features are changed, or when significant construction changes are made. However, some specifications of the products may be changed without any notice. When in doubt, special model numbers may be assigned to fix or establish key specifications for your application on your request. Please consult with your OMRON representative at any time to confirm actual specifications of purchased products.

DIMENSIONS AND WEIGHTS

Dimensions and weights are nominal and are not to be used for manufacturing purposes, even when tolerances are shown.

PERFORMANCE DATA

Performance data given in this catalog is provided as a guide for the user in determining suitability and does not constitute a warranty. It may represent the result of OMRON's test conditions, and the users must correlate it to actual application requirements. Actual performance is subject to the OMRON Warranty and Limitations of Liability.

ERRORS AND OMISSIONS

The information in this document has been carefully checked and is believed to be accurate; however, no responsibility is assumed for clerical, typographical, or proofreading errors, or omissions.

2009.4

In the interest of product improvement, specifications are subject to change without notice.

OMRON Corporation
Industrial Automation Company

<http://www.ia.omron.com/>

(c)Copyright OMRON Corporation 2009 All Right Reserved.



Компания «ЭлектроПласт» предлагает заключение долгосрочных отношений при поставках импортных электронных компонентов на взаимовыгодных условиях!

Наши преимущества:

- Оперативные поставки широкого спектра электронных компонентов отечественного и импортного производства напрямую от производителей и с крупнейших мировых складов;
- Поставка более 17-ти миллионов наименований электронных компонентов;
- Поставка сложных, дефицитных, либо снятых с производства позиций;
- Оперативные сроки поставки под заказ (от 5 рабочих дней);
- Экспресс доставка в любую точку России;
- Техническая поддержка проекта, помощь в подборе аналогов, поставка прототипов;
- Система менеджмента качества сертифицирована по Международному стандарту ISO 9001;
- Лицензия ФСБ на осуществление работ с использованием сведений, составляющих государственную тайну;
- Поставка специализированных компонентов (Xilinx, Altera, Analog Devices, Intersil, Interpoint, Microsemi, Aeroflex, Peregrine, Syfer, Eurofarad, Texas Instrument, Miteq, Cobham, E2V, MA-COM, Hittite, Mini-Circuits, General Dynamics и др.);

Помимо этого, одним из направлений компании «ЭлектроПласт» является направление «Источники питания». Мы предлагаем Вам помощь Конструкторского отдела:

- Подбор оптимального решения, техническое обоснование при выборе компонента;
- Подбор аналогов;
- Консультации по применению компонента;
- Поставка образцов и прототипов;
- Техническая поддержка проекта;
- Защита от снятия компонента с производства.



Как с нами связаться

Телефон: 8 (812) 309 58 32 (многоканальный)

Факс: 8 (812) 320-02-42

Электронная почта: org@eplast1.ru

Адрес: 198099, г. Санкт-Петербург, ул. Калинина, дом 2, корпус 4, литера А.