

PRODUCT NUMBER
SEE SHEET 3

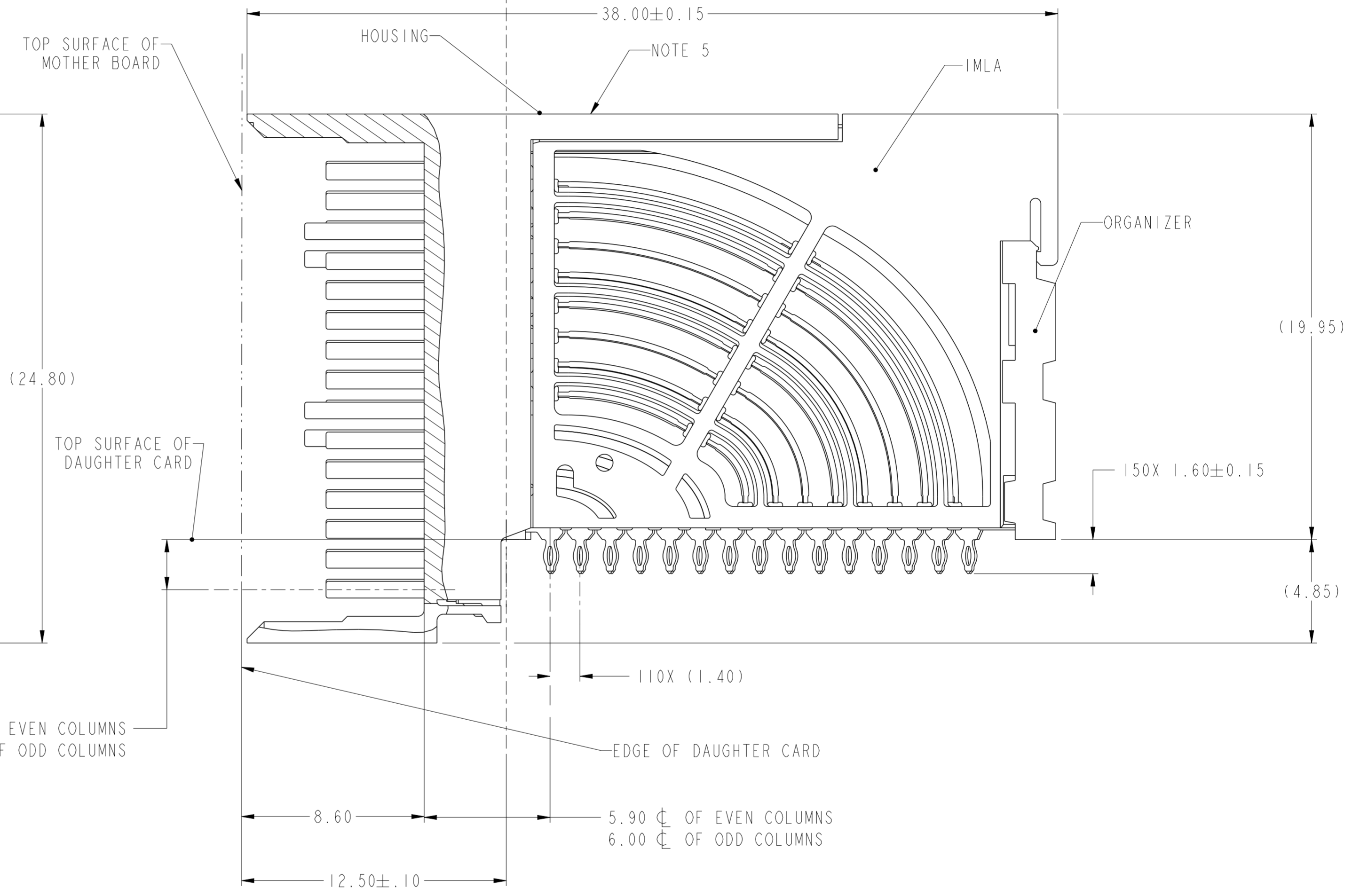
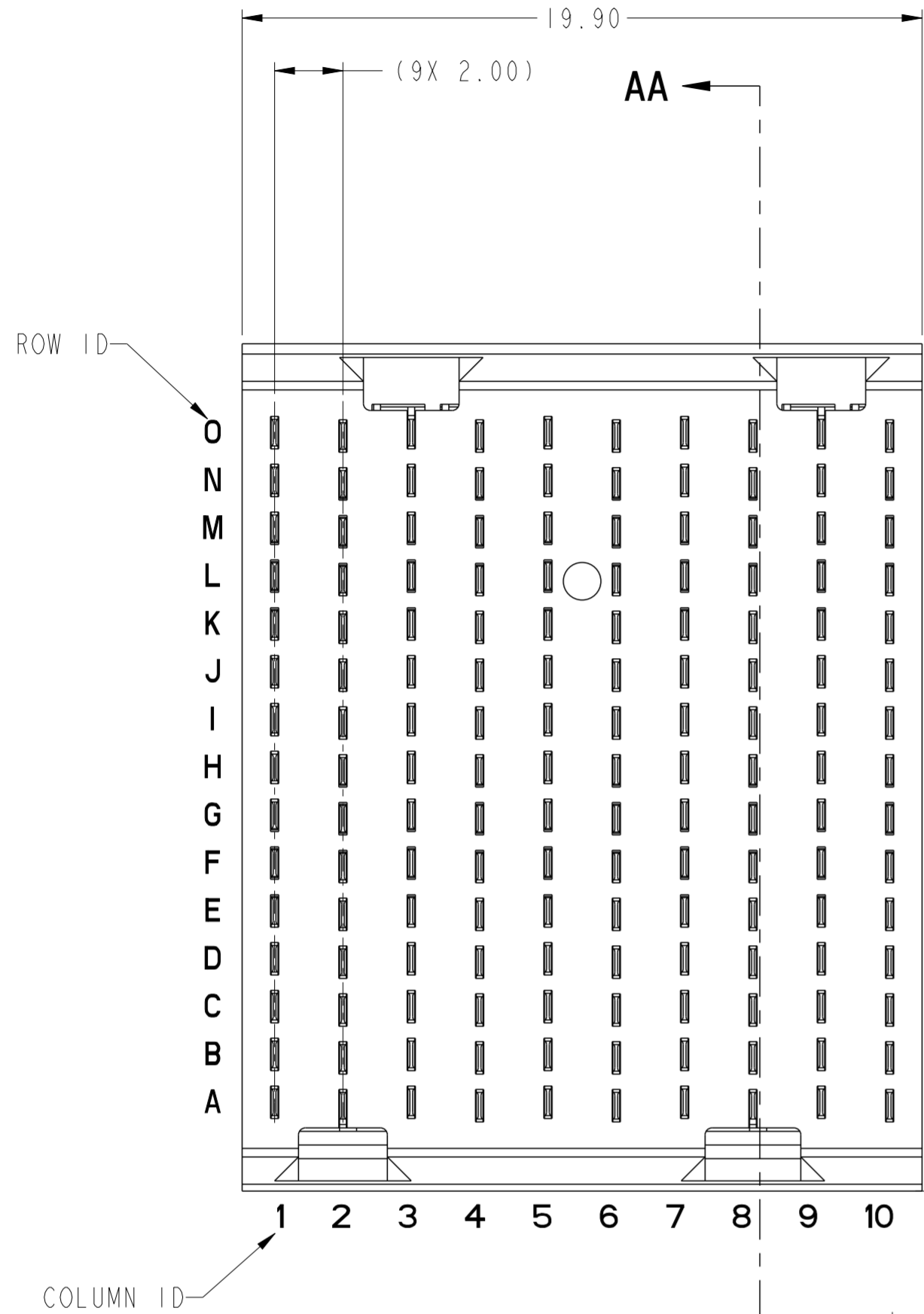

SECTION AA-AA

spec ref	---	dr	N Anandakumar	2013/01/16	projection	MM	size	A2	scale	10:1									
tolerance std	ASME Y14.5M	eng	Art Lin	2016/11/14			ecn no	ELX-DG-25255-1	rel level	Released									
TOLERANCES UNLESS OTHERWISE SPECIFIED		chr	Heaven Cen	2016/11/17															
		appr	Pai-Ming Zheng	2016/11/18															
surface	<table border="1"> <tr> <td>linear</td> <td>0.X</td> <td>±.3</td> </tr> <tr> <td></td> <td>0.XX</td> <td>±.15</td> </tr> <tr> <td></td> <td>0.XXX</td> <td>±.050</td> </tr> <tr> <td>angular</td> <td>0°</td> <td>±2°</td> </tr> </table>	linear	0.X	±.3		0.XX	±.15		0.XXX	±.050	angular	0°	±2°			Product Family AirMax VS2 R.A. HEADER 5 Pair, 150 pos, 2mm, 10 Col		dwg no 10123881	rev D
linear	0.X	±.3																	
	0.XX	±.15																	
	0.XXX	±.050																	
angular	0°	±2°																	
		www.fci.com		cat. no.	Product - Customer Drw		sheet 1 of 3												

Amphenol FCI

© 2016 APCI

DESCRIPTION	DIM "D"	DIM "E"	DIM "F"
2-20MM MODULES PLACED END TO END	2.0	19.90 2X	20.00
1-20MM MODULE & 1-22MM MODULE PLACE END TO END	3.0	19.90 1X & 21.90 1X	21.00

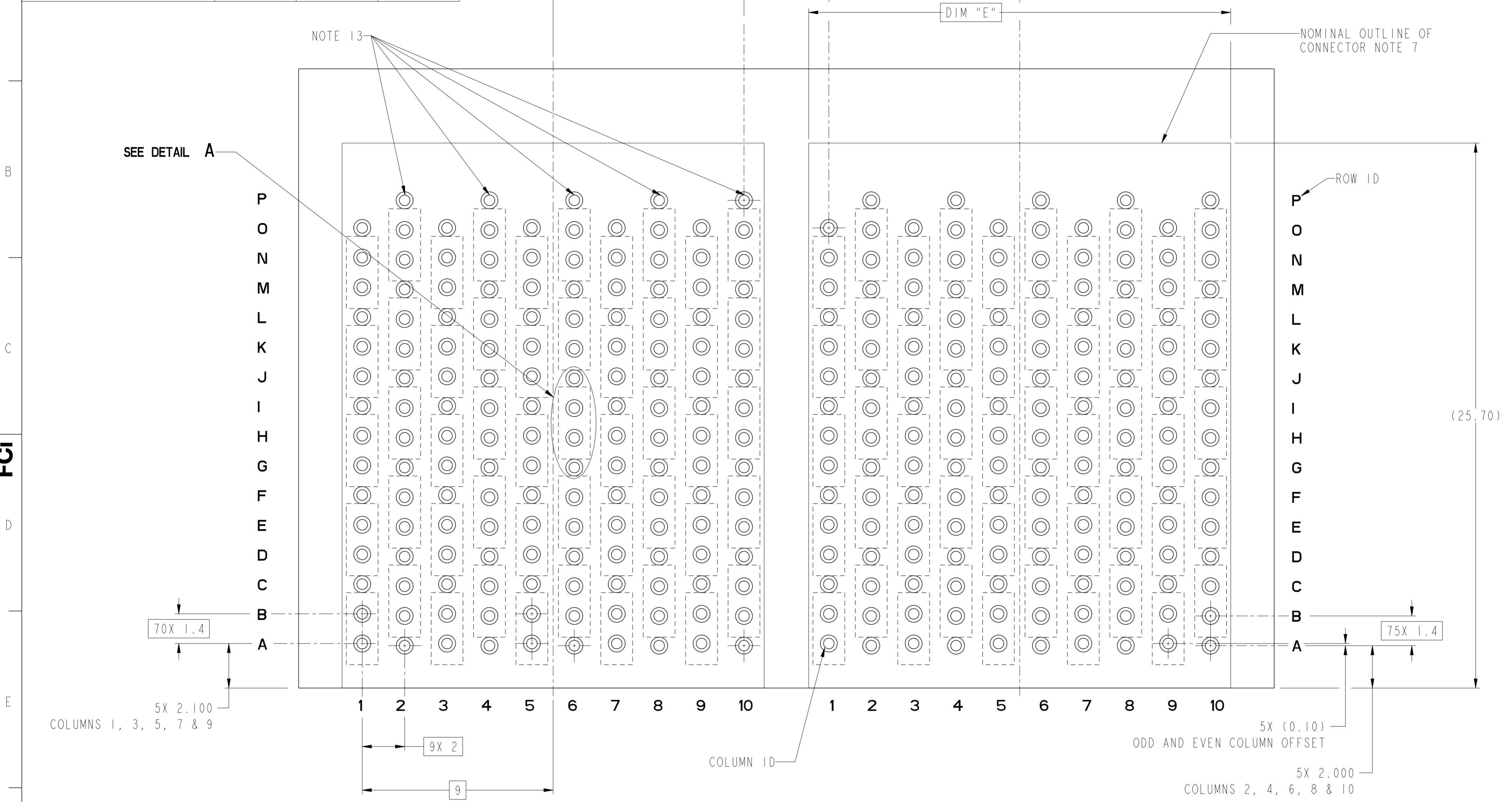

RECOMMENDED PCB LAYOUT
FOR DIFFERENTIAL APPLICATIONS
COMPONENT SIDE
(TWO ADJACENT FOOTPRINTS SHOWN)
NOTES 8 & 11
SCALE 8:1

spec ref	---	dr	N Anandakumar	2013/01/16	projection	MM	size	A2	scale	8:1
tolerance std	ASME Y14.5M	eng	Art Lin	2016/11/14			ecn no	ELX-DG-2525-1	rel level	Released
TOLERANCES UNLESS OTHERWISE SPECIFIED		chr	Heaven Cen	2016/11/17						
		appr	Pai-Ming Zheng	2016/11/18						
surface	linear	0.X	±.3	Amphenol FCI www.fci.com	product family		title AirMax VS2 R.A. HEADER 5 Pair, 150 pos, 2mm, 10 Col	drg no 10123881	rev D	
		0.XX	±.15		-					
		0.XXX	±.050		-					
	angular	0°	±2°	cat. no.	-		Product - Customer Drw		sheet 2 of 3	

Amphenol FCI

© 2016 APCI

PRODUCT NUMBER	PRESS-FIT TAIL PLATING TYPE	REMARK
10123881-101	TIN/LEAD ALLOY OVER NICKEL	1-SIDE PLATING (CUSTOMER SPECIAL)
10123881-101LF	TIN OVER NICKEL (LEAD FREE)	
10123881-102	TIN/LEAD ALLOY OVER NICKEL	2-SIDE PLATING
10123881-102LF	TIN OVER NICKEL (LEAD FREE)	

- 1 - CONNECTOR MATERIALS:
HOUSING: HIGH TEMP THERMOPLASTIC, NATURAL, UL94-V0
IMLA PLASTIC: HIGH TEMP THERMOPLASTIC, BLACK, UL94-V0
CONTACT: COPPER ALLOY
ORGANIZER: HIGH TEMP THERMOPLASTIC, NATURAL, UL94-V0
- 2 - CONTACT PLATING:
SEPARABLE INTERFACE:
PERFORMANCE-BASED PLATING, QUALIFIED TO MEET THE REQUIREMENTS OF FCI PRODUCT SPECIFICATION GS-12-0956 INCLUDING TELCORDIA GR-1217-CORE (NOVEMBER 1995) CENTRAL OFFICE TEST SEQUENCE
- PRESS-FIT TAILS: SEE TABLE
- 3 - PRODUCT SPECIFICATION: GS-12-0956
- 4 - APPLICATION SPECIFICATION: GS-20-0305
- 5 - PRODUCT MARKING, (PROTOTYPE, PART NUMBER & LOT CODE), ON THIS SURFACE.
- 6 - POSITIONS "F" AND "L" OF ODD NUMBERED COLUMNS AND POSITIONS "G" AND "M" OF EVEN NUMBERED COLUMNS CORRESPOND TO EARLY MATE HEADER PINS.
- 7 - CONNECTOR OUTLINE MAY BE SCREEN PRINTED ONTO CUSTOMER PCB TO BE USED AS A GUIDE FOR CONNECTOR PLACEMENT.
- 8 - REFER TO CUSTOMER DRAWING 10104444 FOR INFORMATION ON PCB HOLE DIAMETERS AND PLATING OPTIONS
- 9 - LEAD FREE PRODUCT MEETS THE EUROPEAN UNION DIRECTIVES & OTHER COUNTRY REGULATIONS AS DESCRIBED IN GS-22-008
- 10 - PACKAGING MEETS GS-14-920 LEAD FREE LABELING SPECIFICATION.
- 11 - GROUND CONTACTS (C, F, I, L, & O IN ODD COLUMNS AND A, D, G, J, & M IN EVEN COLUMNS) REQUIRE (Ø0.50) FINISHED HOLES. SIGNAL LOCATIONS REQUIRE (Ø0.50) FINISHED HOLES
- 12 - THESE OUTER VIAS (P) ARE OPTIONAL. WHILE NO CONNECTOR EONS ARE PRESSED INTO THESE HOLES WE RECCOMEND (Ø0.500) FINISHED HOLES AT THESE LOCATIONS TO PROVIDE GROUND SYMMETRY THROUGH THE PCB.
- 13 - A  SYMBOL WILL BE NEXT TO ANY DIMENSION, VIEW, OR NOTE, WHICH HAS BEEN MODIFIED WITH THE CURRENT DRAWING REVISION.

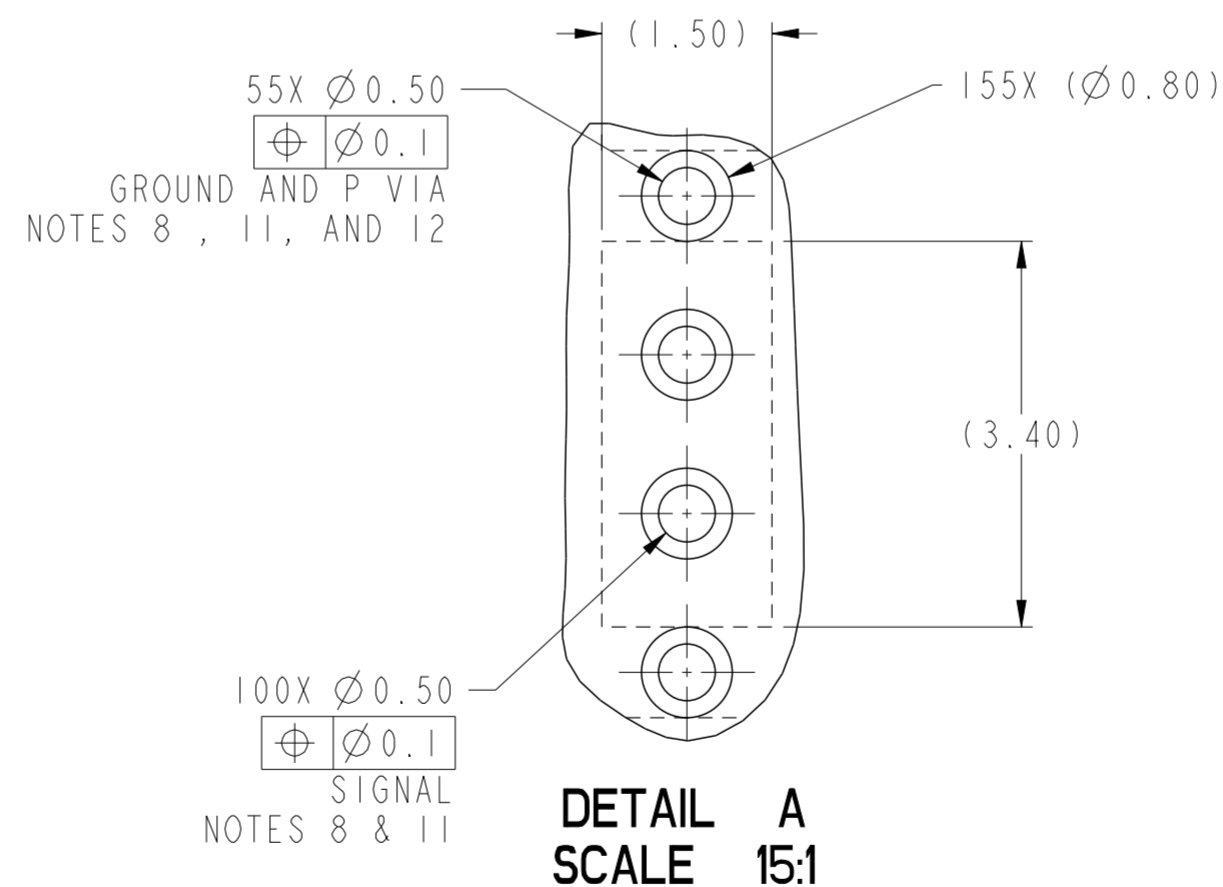
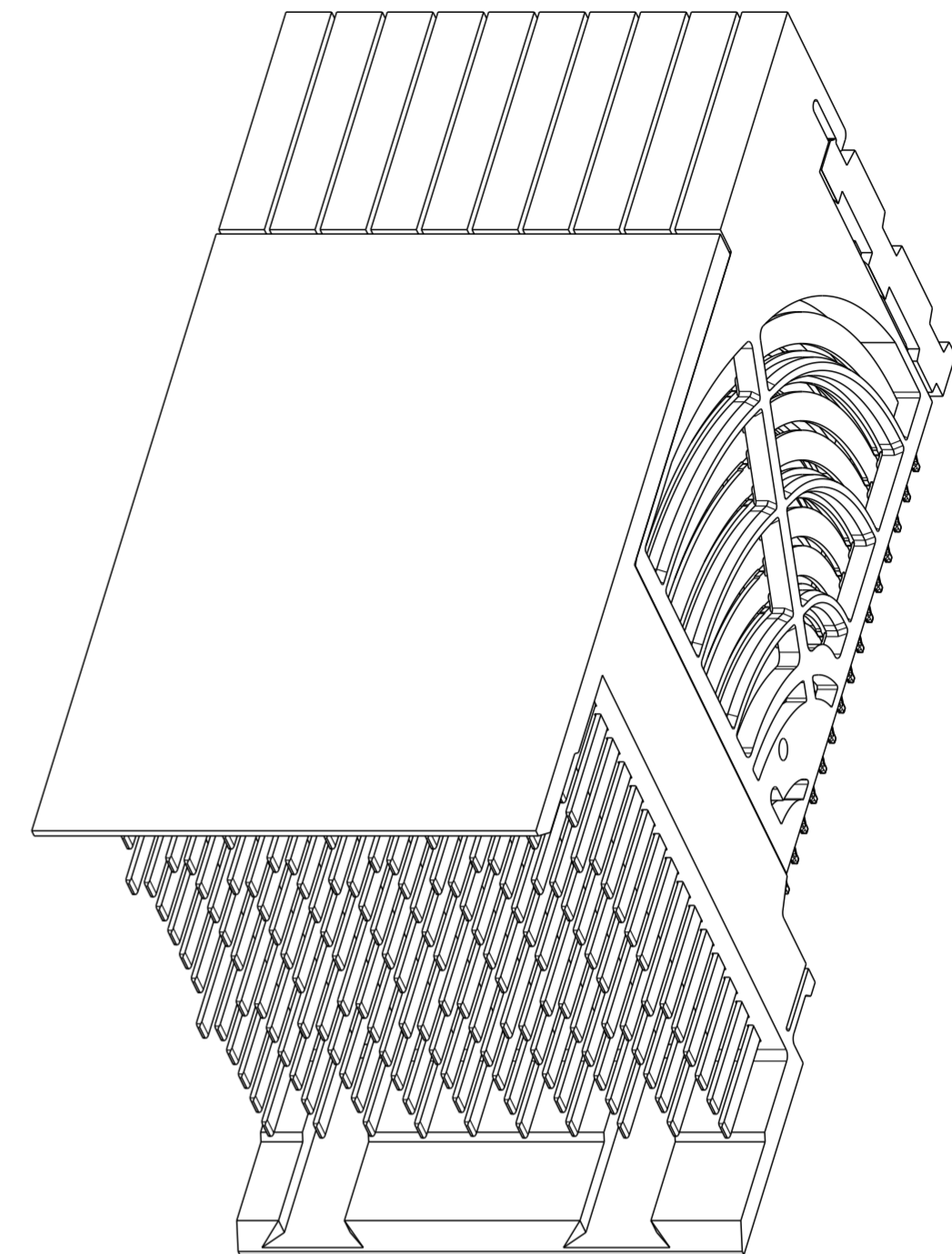

10123881-101 OR -101LF
10123881-102 OR -102LF

SCALE 4:1

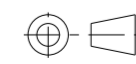
spec ref	---	dr	N Anandakumar	2013/01/16	projection	MM	size	A2	scale	10:1				
tolerance std	ASME Y14.5M	eng	Art Lin	2016/11/14		← →	ecn no	ELX-DG-2525-1	rel level	Released				
TOLERANCES UNLESS OTHERWISE SPECIFIED		chr	Heaven Cen	2016/11/17										
surface	linear	0.X	±.3	Amphenol FCI www.fci.com	product family		-	rel level	Released	rev				
		0.XX	±.15		AirMax VS2 R.A. HEADER	5 Pair, 150 pos, 2mm, 10 Col					-	rel level	Released	rev
		0.XXX	±.050											
	angular	0°	±2°											

PDS: Rev :D

STATUS:Released

Printed: Nov 18, 2016

Amphenol FCI

© 2016 AFCI



Компания «ЭлектроПласт» предлагает заключение долгосрочных отношений при поставках импортных электронных компонентов на взаимовыгодных условиях!

Наши преимущества:

- Оперативные поставки широкого спектра электронных компонентов отечественного и импортного производства напрямую от производителей и с крупнейших мировых складов;
- Поставка более 17-ти миллионов наименований электронных компонентов;
- Поставка сложных, дефицитных, либо снятых с производства позиций;
- Оперативные сроки поставки под заказ (от 5 рабочих дней);
- Экспресс доставка в любую точку России;
- Техническая поддержка проекта, помощь в подборе аналогов, поставка прототипов;
- Система менеджмента качества сертифицирована по Международному стандарту ISO 9001;
- Лицензия ФСБ на осуществление работ с использованием сведений, составляющих государственную тайну;
- Поставка специализированных компонентов (Xilinx, Altera, Analog Devices, Intersil, Interpoint, Microsemi, Aeroflex, Peregrine, Syfer, Eurofarad, Texas Instrument, Miteq, Cobham, E2V, MA-COM, Hittite, Mini-Circuits, General Dynamics и др.);

Помимо этого, одним из направлений компании «ЭлектроПласт» является направление «Источники питания». Мы предлагаем Вам помощь Конструкторского отдела:

- Подбор оптимального решения, техническое обоснование при выборе компонента;
- Подбор аналогов;
- Консультации по применению компонента;
- Поставка образцов и прототипов;
- Техническая поддержка проекта;
- Защита от снятия компонента с производства.



Как с нами связаться

Телефон: 8 (812) 309 58 32 (многоканальный)

Факс: 8 (812) 320-02-42

Электронная почта: org@eplast1.ru

Адрес: 198099, г. Санкт-Петербург, ул. Калинина, дом 2, корпус 4, литера А.