

THIS DRAWING IS UNPUBLISHED. RELEASED FOR PUBLICATION
 © COPYRIGHT - By - ALL RIGHTS RESERVED.

LOC		DIST		REVISIONS			
P	LTR	DESCRIPTION		DATE	DWN	APVD	
AD	00	F7		REVISED PER ECO-13-005565	01APR13	KH	JO

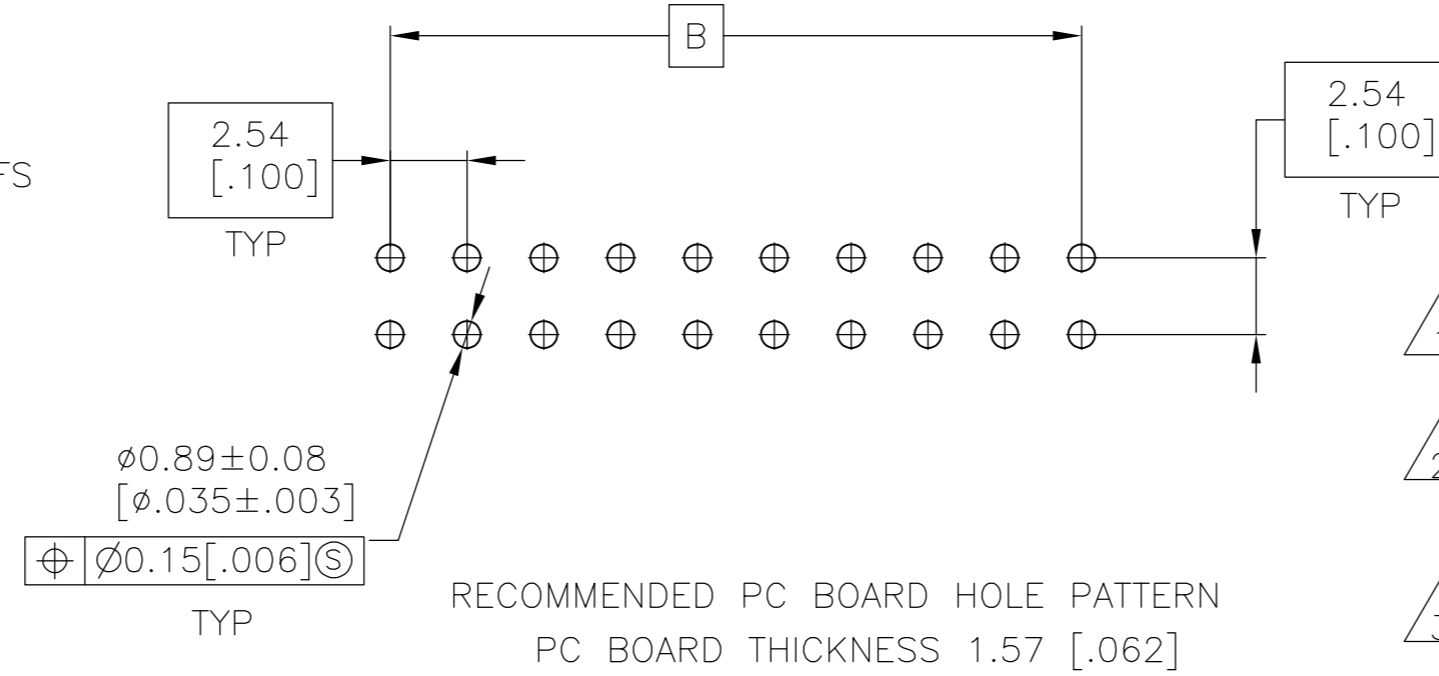

- 1 HOUSING: FLAME RETARDANT, GLASS FILLED, POLYESTER, COLOR: BLACK. CONTACT: PHOSPHOR BRONZE
- 2 CONTACT: DUPLEX PLATED 0.25 μ m[.000010] MIN GOLD IN CONTACT AREA, 3.81-7.62 μ m[.000150-.000300] BRIGHT TIN-LEAD ON LEADS ALL OVER 1.27 μ m[.000050] MINIMUM NICKEL.
- 3 THESE DIMENSIONS PERTAIN TO CAVITY CENTERLINES ONLY - NOT TO CONTACT LOCATIONS
- 4 MARK PART NUMBER AND DATE CODE IN APPROXIMATE LOCATION SHOWN, EITHER SIDE.
- 5 TOLERANCE IS NON-CUMULATIVE.
- 6 2 POSITION DATE CODE IS MARKED OPPOSITE SIDE OF TE LOGO.
- 7 POINT-OF-MEASUREMENT DIMENSION FOR PLATING THICKNESS (INSIDE CONTACT BEAM).
- 8 POINT-OF-CONTACT DIMENSION.
- 9 NO PART NUMBER MARKING REQUIRED FOR THIS PART.
- 10 TE LOGO AND CSA LOGO ARE MOLDED INTO HOUSING.
- 11 CONTACT: DUPLEX PLATED 0.25 μ m[.000010] MIN GOLD IN CONTACT AREA, 3.81-7.62 μ m[.000150-.000300] MATTE TIN ON LEADS ALL OVER 1.27 μ m[.000050] MINIMUM NICKEL
- 12 ROHS 2002/95/EC COMPLIANT

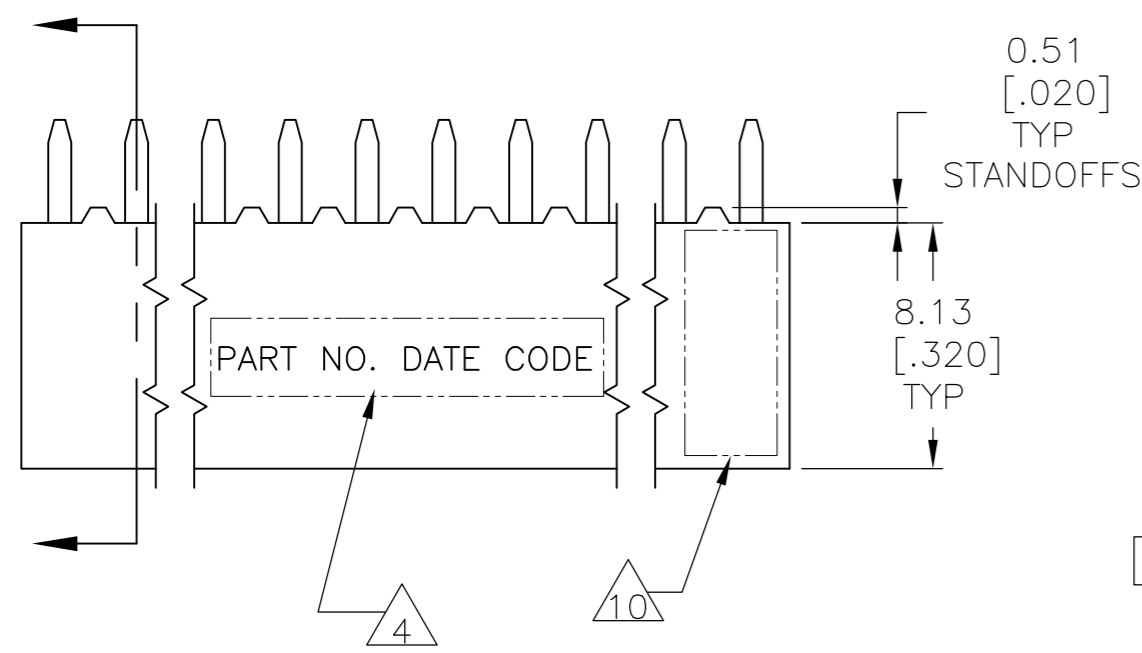
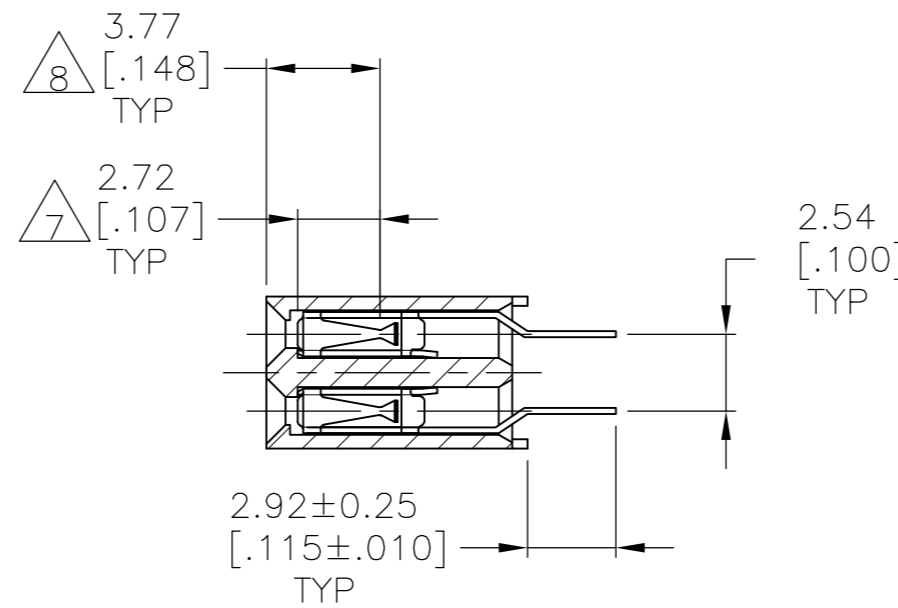
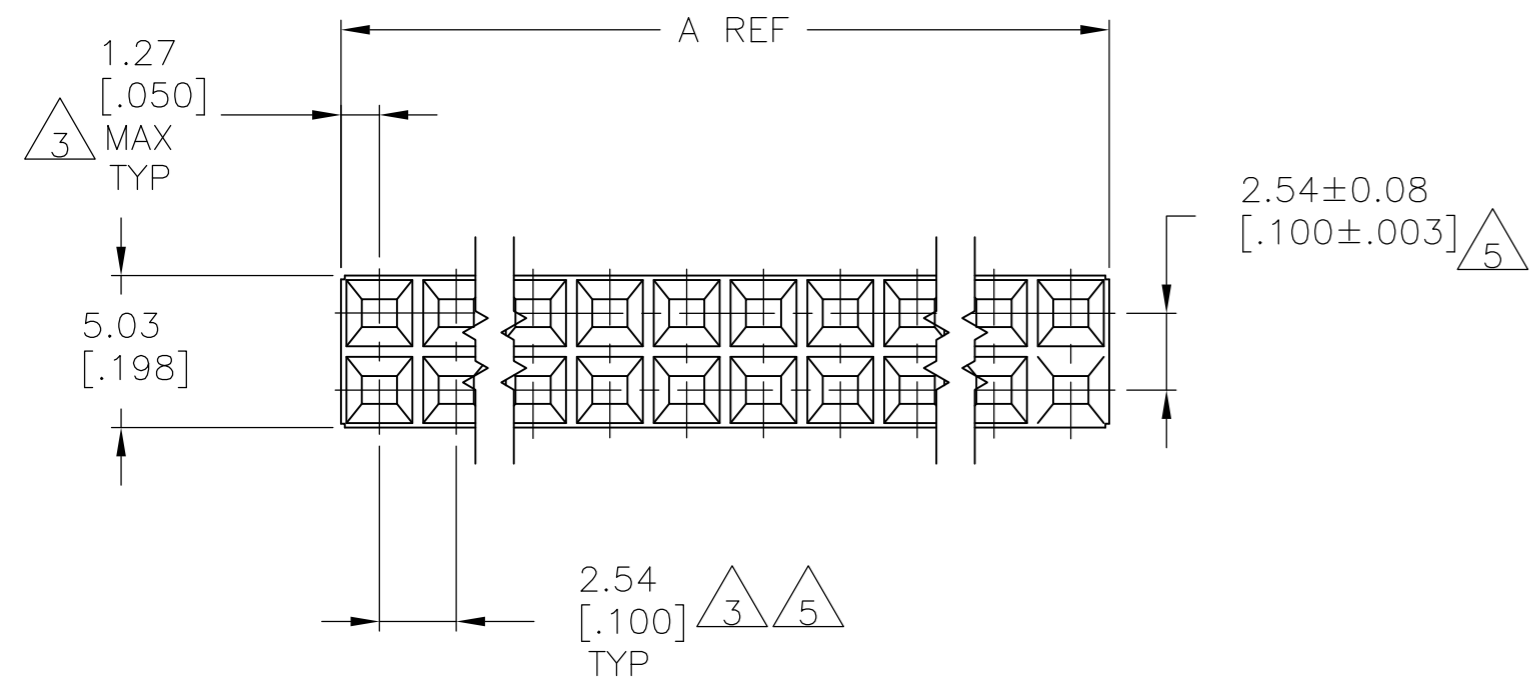

THIS DRAWING IS A CONTROLLED DOCUMENT.		DWN	M.BINNER	06NOV2002	 TE Connectivity								
DIMENSIONS: mm [INCHES]		CHK	J.OLSON	06NOV02									
TOLERANCES UNLESS OTHERWISE SPECIFIED:		APVD	J.OLSON	06NOV02									
0 PLC ± - 1 PLC ± - 2 PLC ± 0.13[.005] 3 PLC ± - 4 PLC ± - ANGLES ± -		PRODUCT SPEC	108-25022	NAME		RECEPTACLE ASSEMBLY, MOD IV, DOUBLE ROW, TOP ENTRY, .100X.100CL, VERTICAL MOUNT, AMPMODU							
MATERIAL	1	FINISH	2 11	APPLICATION SPEC	114-25018	SIZE	A2	CAGE CODE	00779	DRAWING NO	C=147424	RESTRICTED TO	-
CUSTOMER DRAWING		WEIGHT	-	SCALE		4:1	SHEET	1 OF 2	REV	F7			

THIS DRAWING IS UNPUBLISHED. RELEASED FOR PUBLICATION
 © COPYRIGHT - By - ALL RIGHTS RESERVED.

LOC		DIST		REVISIONS			
P	LTR	DESCRIPTION		DATE	DWN	APVD	
		SEE SHEET 1					

2	99.06 [3.900]	101.60 [4.000]	80	4-147424-0
2	96.52 [3.800]	99.06 [3.900]	78	3-147424-9
2	93.98 [3.700]	96.52 [3.800]	76	3-147424-8
2	91.44 [3.600]	93.98 [3.700]	74	3-147424-7
2	88.90 [3.500]	91.44 [3.600]	72	3-147424-6
2	86.36 [3.400]	88.90 [3.500]	70	3-147424-5
2	83.82 [3.300]	86.36 [3.400]	68	3-147424-4
2	81.28 [3.200]	83.82 [3.300]	66	3-147424-3
2	78.74 [3.100]	81.28 [3.200]	64	3-147424-2
2	76.20 [3.000]	78.74 [3.100]	62	3-147424-1
2	73.66 [2.900]	76.20 [3.000]	60	3-147424-0
2	71.12 [2.800]	73.66 [2.900]	58	2-147424-9
2	68.58 [2.700]	71.12 [2.800]	56	2-147424-8
2	66.04 [2.600]	68.58 [2.700]	54	2-147424-7
2	63.50 [2.500]	66.04 [2.600]	52	2-147424-6
2	60.96 [2.400]	63.50 [2.500]	50	2-147424-5
2	58.42 [2.300]	60.96 [2.400]	48	2-147424-4
2	55.88 [2.200]	58.42 [2.300]	46	2-147424-3
2	53.34 [2.100]	55.88 [2.200]	44	2-147424-2
2	50.80 [2.000]	53.34 [2.100]	42	2-147424-1
2	48.26 [1.900]	50.80 [2.000]	40	2-147424-0
2	45.72 [1.800]	48.26 [1.900]	38	1-147424-9
2	43.18 [1.700]	45.72 [1.800]	36	1-147424-8
2	40.64 [1.600]	43.18 [1.700]	34	1-147424-7
2	38.10 [1.500]	40.64 [1.600]	32	1-147424-6
2	35.56 [1.400]	38.10 [1.500]	30	1-147424-5
2	33.02 [1.300]	35.56 [1.400]	28	1-147424-4
2	30.48 [1.200]	33.02 [1.300]	26	1-147424-3
2	27.94 [1.100]	30.48 [1.200]	24	1-147424-2
2	25.40 [1.000]	27.94 [1.100]	22	1-147424-1
2	22.86 [.900]	25.40 [1.000]	20	1-147424-0
2	20.32 [.800]	22.86 [.900]	18	147424-9
2	17.78 [.700]	20.32 [.800]	16	147424-8
2	15.24 [.600]	17.78 [.700]	14	147424-7
2	12.70 [.500]	15.24 [.600]	12	147424-6
2	10.16 [.400]	12.70 [.500]	10	147424-5
2	7.62 [.300]	10.16 [.400]	8	147424-4
2	5.08 [.200]	7.62 [.300]	6	147424-3
2	2.54 [.100]	5.08 [.200]	4	147424-2
2	2.54 [.100]	2.54 [.100]	2	147424-1
FINISH	B	A	NO OF POSN	PART NUMBER

SUPERSEDED BY 7-147424-4

SUPERSEDED BY 7-147424-0

SUPERSEDED BY 6-147424-6

SUPERSEDED BY 6-147424-5

SUPERSEDED BY 6-147424-0

OBSOLETE

11	99.06 [3.900]	101.60 [4.000]	80	9-147424-0
11	96.52 [3.800]	99.06 [3.900]	78	8-147424-9
11	93.98 [3.700]	96.52 [3.800]	76	8-147424-8
11	91.44 [3.600]	93.98 [3.700]	74	8-147424-7
11	88.90 [3.500]	91.44 [3.600]	72	8-147424-6
11	86.36 [3.400]	88.90 [3.500]	70	8-147424-5
11	83.82 [3.300]	86.36 [3.400]	68	8-147424-4
11	81.28 [3.200]	83.82 [3.300]	66	8-147424-3
11	78.74 [3.100]	81.28 [3.200]	64	8-147424-2
11	76.20 [3.000]	78.74 [3.100]	62	8-147424-1
11	73.66 [2.900]	76.20 [3.000]	60	8-147424-0
11	71.12 [2.800]	73.66 [2.900]	58	7-147424-9
11	68.58 [2.700]	71.12 [2.800]	56	7-147424-8
11	66.04 [2.600]	68.58 [2.700]	54	7-147424-7
11	63.50 [2.500]	66.04 [2.600]	52	7-147424-6
11	60.96 [2.400]	63.50 [2.500]	50	7-147424-5
11	58.42 [2.300]	60.96 [2.400]	48	7-147424-4
11	55.88 [2.200]	58.42 [2.300]	46	7-147424-3
11	53.34 [2.100]	55.88 [2.200]	44	7-147424-2
11	50.80 [2.000]	53.34 [2.100]	42	7-147424-1
11	48.26 [1.900]	50.80 [2.000]	40	7-147424-0
11	45.72 [1.800]	48.26 [1.900]	38	6-147424-9
11	43.18 [1.700]	45.72 [1.800]	36	6-147424-8
11	40.64 [1.600]	43.18 [1.700]	34	6-147424-7
11	38.10 [1.500]	40.64 [1.600]	32	6-147424-6
11	35.56 [1.400]	38.10 [1.500]	30	6-147424-5
11	33.02 [1.300]	35.56 [1.400]	28	6-147424-4
11	30.48 [1.200]	33.02 [1.300]	26	6-147424-3
11	27.94 [1.100]	30.48 [1.200]	24	6-147424-2
11	25.40 [1.000]	27.94 [1.100]	22	6-147424-1
11	22.86 [.900]	25.40 [1.000]	20	6-147424-0
11	20.32 [.800]	22.86 [.900]	18	5-147424-9
11	17.78 [.700]	20.32 [.800]	16	5-147424-8
11	15.24 [.600]	17.78 [.700]	14	5-147424-7
11	12.70 [.500]	15.24 [.600]	12	5-147424-6
11	10.16 [.400]	12.70 [.500]	10	5-147424-5
11	7.62 [.300]	10.16 [.400]	8	5-147424-4
11	5.08 [.200]	7.62 [.300]	6	5-147424-3
11	2.54 [.100]	5.08 [.200]	4	5-147424-2
11	2.54 [.100]	2.54 [.100]	2	5-147424-1
FINISH	B	A	NO OF POSN	PART NUMBER

OBSOLETE

THIS DRAWING IS A CONTROLLED DOCUMENT.		DWN M.BINNER 06NOV2002	 TE Connectivity	
DIMENSIONS: mm [INCHES]		CHK J.OLSON 06NOV02		
TOLERANCES UNLESS OTHERWISE SPECIFIED:		APVD J.OLSON 06NOV02	NAME	
0 PLC ± - 1 PLC ± - 2 PLC ± 0.13 [.005] 3 PLC ± - 4 PLC ± - ANGLES ± -		PRODUCT SPEC 108-25022	RECEPTACLE ASSEMBLY, MOD IV, DOUBLE ROW, TOP ENTRY, .100X.100CL, VERTICAL MOUNT, AMPMODU	
MATERIAL		APPLICATION SPEC 114-25018	SIZE A2	CAGE CODE 00779
FINISH		WEIGHT -	DRAWING NO C=147424	RESTRICTED TO -
CUSTOMER DRAWING		SCALE 1:1	SHEET 2 OF 2	REV F7



Компания «ЭлектроПласт» предлагает заключение долгосрочных отношений при поставках импортных электронных компонентов на взаимовыгодных условиях!

Наши преимущества:

- Оперативные поставки широкого спектра электронных компонентов отечественного и импортного производства напрямую от производителей и с крупнейших мировых складов;
- Поставка более 17-ти миллионов наименований электронных компонентов;
- Поставка сложных, дефицитных, либо снятых с производства позиций;
- Оперативные сроки поставки под заказ (от 5 рабочих дней);
- Экспресс доставка в любую точку России;
- Техническая поддержка проекта, помощь в подборе аналогов, поставка прототипов;
- Система менеджмента качества сертифицирована по Международному стандарту ISO 9001;
- Лицензия ФСБ на осуществление работ с использованием сведений, составляющих государственную тайну;
- Поставка специализированных компонентов (Xilinx, Altera, Analog Devices, Intersil, Interpoint, Microsemi, Aeroflex, Peregrine, Syfer, Eurofarad, Texas Instrument, Miteq, Cobham, E2V, MA-COM, Hittite, Mini-Circuits, General Dynamics и др.);

Помимо этого, одним из направлений компании «ЭлектроПласт» является направление «Источники питания». Мы предлагаем Вам помощь Конструкторского отдела:

- Подбор оптимального решения, техническое обоснование при выборе компонента;
- Подбор аналогов;
- Консультации по применению компонента;
- Поставка образцов и прототипов;
- Техническая поддержка проекта;
- Защита от снятия компонента с производства.



Как с нами связаться

Телефон: 8 (812) 309 58 32 (многоканальный)

Факс: 8 (812) 320-02-42

Электронная почта: org@eplast1.ru

Адрес: 198099, г. Санкт-Петербург, ул. Калинина, дом 2, корпус 4, литера А.