



## Features

- Compliant with AEC-Q200 Rev-C- Stress Test Qualification for Passive Components in Automotive Applications
- Operating temperature range up to 125 °C
- Low thermal derating factor
- Higher hold currents at elevated temperature
- Choice of operating currents
- RoHS compliant\* and Pb free
- Resettable fault protection of general electronic equipment

## MF-RHT Series - PTC Resettable Fuses

### Electrical Characteristics

| Model      | V max. Volts | I max. Amps | I <sub>hold</sub> | I <sub>trip</sub> | Resistance        |                                | Max. Time To Trip |                  | Tripped Power Dissipation |
|------------|--------------|-------------|-------------------|-------------------|-------------------|--------------------------------|-------------------|------------------|---------------------------|
|            |              |             | Amperes at 23 °C  |                   | Ohms at 23 °C     |                                | Amperes at 23 °C  | Seconds at 23 °C | Watts at 23 °C            |
|            |              |             | Hold              | Trip              | R <sub>Min.</sub> | R <sub>1Max.</sub> (Post Trip) |                   | Max.             | Typ.                      |
| MF-RHT070  | 16           | 40          | 0.7               | 1.4               | 0.3               | 0.8                            | 3.5               | 4.0              | 1.4                       |
| MF-RHT200  | 16           | 100         | 2.0               | 3.8               | 0.045             | 0.110                          | 12.5              | 3.0              | 1.4                       |
| MF-RHT450  | 16           | 100         | 4.5               | 7.8               | 0.022             | 0.054                          | 22.5              | 3.0              | 3.6                       |
| MF-RHT650  | 16           | 100         | 6.5               | 12.0              | 0.011             | 0.026                          | 32.5              | 5.5              | 4.3                       |
| MF-RHT750  | 16           | 100         | 7.5               | 13.1              | 0.0094            | 0.022                          | 37.5              | 7.0              | 4.5                       |
| MF-RHT1300 | 16           | 100         | 13.0              | 24.0              | 0.0041            | 0.010                          | 60.0              | 13.0             | 6.9                       |

### Environmental Characteristics

|                            |   |
|----------------------------|---|
| Operating Temperature..... | -40 °C to +125 °C   |
| Storage Temperature.....   | -40 °C to +85 °C  |
| Passive Aging.....         | +85 °C, 1000 hours..... ±15 % typical resistance change           |
| Humidity Aging.....        | +85 °C, 85 % R.H. 1000 hours..... ±15 % typical resistance change |
| Thermal Shock.....         | MIL-STD-202, Method 107..... ±10 % typical resistance change      |
|                            | +125 °C to -40 °C, 10 cycles                                      |
| Vibration.....             | MIL-STD-883C, Method 2007.1, Condition A..... No change           |

### Test Procedures And Requirements For Model MF-RHT Series

| Test                 | Test Conditions                                       | Accept/Reject Criteria                   |
|----------------------|---|--|
| Visual/Mech.....     | Verify dimensions and materials.....                  | Per MF physical description              |
| Resistance.....      | In still air @ 23 °C.....                             | R <sub>min</sub> ≤ R ≤ R <sub>1max</sub> |
| Time to Trip.....    | At specified current, V <sub>max</sub> , 23 °C.....   | T ≤ max. time to trip (seconds)          |
| Hold Current.....    | 30 min. at I <sub>hold</sub> .....                    | No trip                                  |
| Trip Cycle Life..... | V <sub>max</sub> , I <sub>max</sub> , 100 cycles..... | No arcing or burning                     |
| Trip Endurance.....  | V <sub>max</sub> , 48 hours.....                      | No arcing or burning                     |
| Solderability.....   | MIL-STD-202, Method 208.....                          | 95 % min. coverage                       |

### Thermal Derating Chart - I<sub>hold</sub> (Amps)

| Model      | Ambient Operating Temperature |        |      |       |       |       |       |       |       |        |
|------------|-------------------------------|--------|------|-------|-------|-------|-------|-------|-------|--------|
|            | -40 °C                        | -20 °C | 0 °C | 23 °C | 40 °C | 50 °C | 60 °C | 70 °C | 85 °C | 125 °C |
| MF-RHT070  | 0.95                          | 0.87   | 0.79 | 0.7   | 0.62  | 0.56  | 0.51  | 0.47  | 0.39  | 0.17   |
| MF-RHT200  | 2.71                          | 2.49   | 2.26 | 2.00  | 1.77  | 1.60  | 1.46  | 1.34  | 1.11  | 0.49   |
| MF-RHT450  | 6.1                           | 5.6    | 5.1  | 4.5   | 4.0   | 3.6   | 3.3   | 3.0   | 2.5   | 1.1    |
| MF-RHT650  | 8.8                           | 8.1    | 7.4  | 6.5   | 5.7   | 5.3   | 4.8   | 4.3   | 3.6   | 1.6    |
| MF-RHT750  | 10.2                          | 9.4    | 8.6  | 7.5   | 6.6   | 6.1   | 5.6   | 5.0   | 4.1   | 1.9    |
| MF-RHT1300 | 17.7                          | 16.3   | 14.8 | 13.0  | 11.4  | 10.5  | 9.6   | 8.6   | 7.2   | 3.3    |

### How to Order

**MF - RHT 750 -**

|                                 |  |
|---------------------------------|--|
| Multifuse® Product Designator   | MF - RHT 750 -   |
| Series                          | RHT = High Temperature Radial Leaded Component                 |
| Hold Current, I <sub>hold</sub> | 070 - 1300 (0.70 - 13.00 Amps)                                 |
| Packaging Options               | - = Bulk Packaging<br>- 2 = Tape and Reel*<br>- AP = Ammo-Pak* |

\*Packaged per EIA 486-B

\*RoHS Directive 2002/95/EC Jan 27 2003 including Annex.

Specifications are subject to change without notice.

Customers should verify actual device performance in their specific applications.

## Applications

- Protection of automotive circuitry including engine control modules
- Overcurrent surge protection of electronic equipment required to operate at high operating temperature ranges
- Resettable fault protection of general electronic equipment

## MF-RHT Series - PTC Resettable Fuses

**BOURNS®**

### Product Dimensions

| Model      | A                      | B                      | C                      |                       | D                    | E                    | F                      | Physical Characteristics |          |
|------------|------------------------|------------------------|------------------------|-----------------------|----------------------|----------------------|------------------------|--------------------------|----------|
|            | Max.                   | Max.                   | Nom.                   | Tol. ±                | Min.                 | Max.                 | Nom.                   | Style                    | Material |
| MF-RHT070  | $\frac{6.86}{(0.27)}$  | $\frac{10.8}{(0.425)}$ | $\frac{5.1}{(0.201)}$  | $\frac{0.7}{(0.028)}$ | $\frac{7.6}{(0.30)}$ | $\frac{3.0}{(0.12)}$ | $\frac{0.51}{(0.020)}$ | 1                        | Sn/CuFe  |
| MF-RHT200  | $\frac{9.4}{(0.37)}$   | $\frac{14.0}{(0.55)}$  | $\frac{5.1}{(0.201)}$  | $\frac{0.7}{(0.028)}$ | $\frac{7.6}{(0.30)}$ | $\frac{3.0}{(0.12)}$ | $\frac{0.51}{(0.020)}$ | 3                        | Sn/Cu    |
| MF-RHT450  | $\frac{10.4}{(0.41)}$  | $\frac{15.6}{(0.61)}$  | $\frac{5.1}{(0.201)}$  | $\frac{0.7}{(0.028)}$ | $\frac{7.6}{(0.30)}$ | $\frac{3.0}{(0.12)}$ | $\frac{0.81}{(0.032)}$ | 2                        | Sn/Cu    |
| MF-RHT650  | $\frac{12.7}{(0.50)}$  | $\frac{22.2}{(0.88)}$  | $\frac{5.1}{(0.201)}$  | $\frac{0.7}{(0.028)}$ | $\frac{7.6}{(0.30)}$ | $\frac{3.0}{(0.12)}$ | $\frac{0.81}{(0.032)}$ | 2                        | Sn/Cu    |
| MF-RHT750  | $\frac{14.0}{(0.55)}$  | $\frac{23.5}{(0.93)}$  | $\frac{5.1}{(0.201)}$  | $\frac{0.7}{(0.028)}$ | $\frac{7.6}{(0.30)}$ | $\frac{3.0}{(0.12)}$ | $\frac{0.81}{(0.032)}$ | 2                        | Sn/Cu    |
| MF-RHT1300 | $\frac{23.5}{(0.925)}$ | $\frac{28.7}{(1.17)}$  | $\frac{10.2}{(0.402)}$ | $\frac{0.7}{(0.028)}$ | $\frac{7.6}{(0.30)}$ | $\frac{3.6}{(0.14)}$ | $\frac{1.0}{(0.040)}$  | 2                        | Sn/Cu    |

Packaging:

BULK: 500 pcs. per bag

TAPE & REEL: MF-RHT070 ~ MF-RHT200 = 3000 pcs. per reel; MF-RHT450 ~ MF-RHT650 = 1500 pcs. per reel;  
MF-RHT750 ~ MF-RHT1300 = 1000 pcs. per reel

AMMO-PACK: MF-RHT070 ~ MF-RHT200 = 2000 pcs. per pack; MF-RHT450 ~ MF-RHT750 = 1000 pcs. per pack;  
MF-RHT1300 = 500 pcs. per pack

0.51 (24AWG) DIMENSIONS:  $\frac{\text{MM}}{\text{(INCHES)}}$   
0.81 (20AWG)  
1.0 (18AWG)

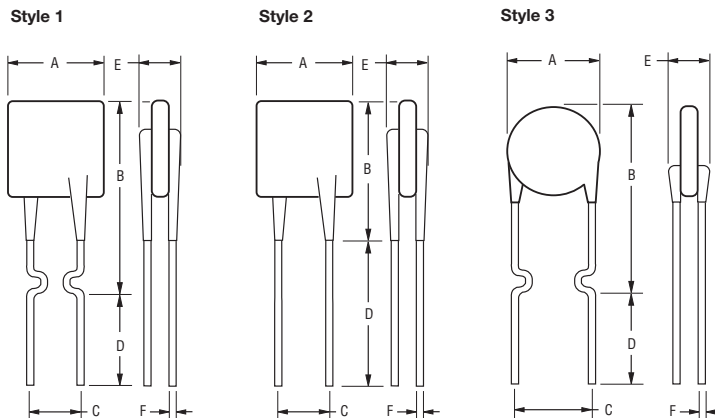

### Typical Part Marking

Represents total content. Layout may vary.



### Typical Time to Trip at 23 °C



The Time to Trip curves represent typical performance of a device in a simulated application environment. Actual performance in specific customer applications may differ from these values due to the influence of other variables.

MF-RHT SERIES, REV. E, 01/10

Specifications are subject to change without notice.  
Customers should verify actual device performance in their specific applications.

# MF-RHT Series Tape and Reel Specifications

**BOURNS®**

Devices taped using EIA468-B/IEC60286-2 standards. See table below and Figures 1 and 2 for details.

| Dimension Description                                     | IEC Mark   | EIA Mark   | Dimensions             |                                    |
|---|------------|------------|------------------------|------------------------------------|
|   |            |            | Dimensions             | Tolerance                          |
| Carrier tape width  | $W$        | $W$        | $\frac{18}{(.709)}$    | $\frac{-0.5/+1.0}{(-0.02/+0.039)}$ |
| Hold down tape width                                      | $W_0$      | $W_4$      | $\frac{11}{(.433)}$    | min.                               |
| Hold down tape  |            |            | No protrusion          |                                    |
| Top distance between tape edges                           | $W_2$      | $W_6$      | $\frac{3}{(.118)}$     | max.                               |
| Sprocket hole position                                    | $W_1$      | $W_5$      | $\frac{9}{(.354)}$     | $\frac{-0.5/+0.75}{(-0.02/+0.03)}$ |
| Sprocket hole diameter                                    | $D_0$      | $D_0$      | $\frac{4}{(.157)}$     | $\frac{\pm 0.2}{(\pm .0078)}$      |
| Abscissa to plane (straight lead)                         | $H$        | $H$        | $\frac{18.5}{(.728)}$  | $\frac{\pm 3.0}{(\pm .118)}$       |
| Abscissa to plane (kinked lead)                           | $H_0$      | $H_0$      | $\frac{16}{(.63)}$     | $\frac{\pm 0.5}{(\pm .02)}$        |
| Abscissa to top: MF-RHT070 ~ MF-RHT450                    | $H_1$      | $H_1$      | $\frac{32.2}{(1.268)}$ | max.                               |
| Abscissa to top: MF-RHT650 ~ MF-RHT1300                   | $H_1$      | $H_1$      | $\frac{45.0}{(1.837)}$ | max.                               |
| Overall width w/lead protrusion: MF-RHT070 ~ MF-RHT450    |            | $C_1$      | $\frac{42.5}{(1.673)}$ | max.                               |
| Overall width w/lead protrusion: MF-RHT650 ~ MF-RHT1300   |            | $C_1$      | $\frac{55.0}{(2.165)}$ | max.                               |
| Overall width w/o lead protrusion: MF-RHT070 ~ MF-RHT450  |            | $C_2$      | $\frac{42.5}{(1.673)}$ | max.                               |
| Overall width w/o lead protrusion: MF-RHT650 ~ MF-RHT1300 |            | $C_2$      | $\frac{54.0}{(2.126)}$ | max.                               |
| Lead protrusion   | $l_1$      | $L_1$      | $\frac{1.0}{(.039)}$   | max.                               |
| Protrusion of cutout                                      | $L$        | $L$        | $\frac{11}{(.433)}$    | max.                               |
| Protrusion beyond hold-down tape                          | $l_2$      | $l_2$      | Not specified          |                                    |
| Sprocket hole pitch                                       | $P_0$      | $P_0$      | $\frac{12.7}{(0.5)}$   | $\frac{\pm 0.3}{(\pm .012)}$       |
| Pitch tolerance   |            |            | 20 consecutive         | $\frac{\pm 1}{(\pm .039)}$         |
| Device pitch: MF-RHT070 ~ MF-RHT450                       |            |            | $\frac{12.7}{(0.5)}$   | $\frac{\pm 0.3}{(\pm .012)}$       |
| Device pitch: MF-RHT650 ~ MF-RHT1300                      |            |            | $\frac{25.4}{(1.0)}$   | $\frac{\pm 0.6}{(\pm .024)}$       |
| Tape thickness  | $t$        | $t$        | $\frac{0.9}{(.035)}$   | max.                               |
| Tape thickness with splice: MF-RHT070                     |            | $t_1$      | $\frac{1.5}{(.059)}$   | max.                               |
| Tape thickness with splice: MF-RHT450 ~ MF-RHT1300        |            | $t_1$      | $\frac{2.3}{(.091)}$   | max.                               |
| Splice sprocket hole alignment                            |            |            | $\frac{4.0}{(.157)}$   | $\frac{\pm 0.2}{(\pm .008)}$       |
| Body lateral deviation                                    | $\Delta_h$ | $\Delta_h$ | 0                      | $\frac{\pm 1}{(\pm .039)}$         |
| Body tape plane deviation                                 | $\Delta_p$ | $\Delta_p$ | 0                      | $\frac{\pm 0.3}{(\pm .012)}$       |
| Ordinate to adjacent component lead                       | $P_1$      | $P_1$      | $\frac{3.81}{(.015)}$  | $\frac{\pm 0.07}{(\pm .028)}$      |

Specifications are subject to change without notice.  
Customers should verify actual device performance in their specific applications

DIMENSIONS:  $\frac{\text{MM}}{\text{(INCHES)}}$

# MF-RHT Series Tape and Reel Specifications

**BOURNS®**

| Dimension Description               | IEC Mark       | EIA Mark       | Dimensions              |   |
|-------------------------------------|----------------|----------------|-------------------------|---|
|                                     |                |                | Dimensions              | Tolerance                                 |
| Lead spacing: MF-RHT070 ~ MF-RHT750 | F              | F              | $\frac{5.08}{(0.2)}$    | $\frac{-0.2/+0.8}{(-0.006/+0.031)}$       |
| Lead spacing: MF-RHT1300            | F              | F              | $\frac{10.2}{(0.402)}$  | $\frac{-0.2/+0.8}{(-0.006/+0.031)}$       |
| Reel width: MF-RHT070 ~ MF-RHT450   | w              | W <sub>2</sub> | $\frac{56}{(2.20)}$     | max.                                      |
| Reel width: MF-RHT650 ~ MF-RHT1300  | w              | W <sub>2</sub> | $\frac{63.5}{(2.50)}$   | max.                                      |
| Reel diameter                       | d              | a              | $\frac{370.0}{(14.57)}$ | max.                                      |
| Space between flanges less device   | W <sub>1</sub> | h              | $\frac{4.75}{(.187)}$   | $\frac{\pm 3.25}{(\pm .128)}$             |
| Arbor hole diameter                 | f              | c              | $\frac{26.0}{(1.02)}$   | $\frac{\pm 12.0}{(\pm .472)}$             |
| Core diameter                       | h              | n              | $\frac{80.0}{(3.15)}$   | max.                                      |
| Box                                 |                |                | $\frac{64}{(2.52)}$     | $\frac{372}{(14.6)}$ $\frac{372}{(14.6)}$ |
| Consecutive missing places          |                |                | 3                       | max.                                      |
| Empty places per reel               |                |                | Not specified           |   |

**Taped Component Dimensions - Figure 1**

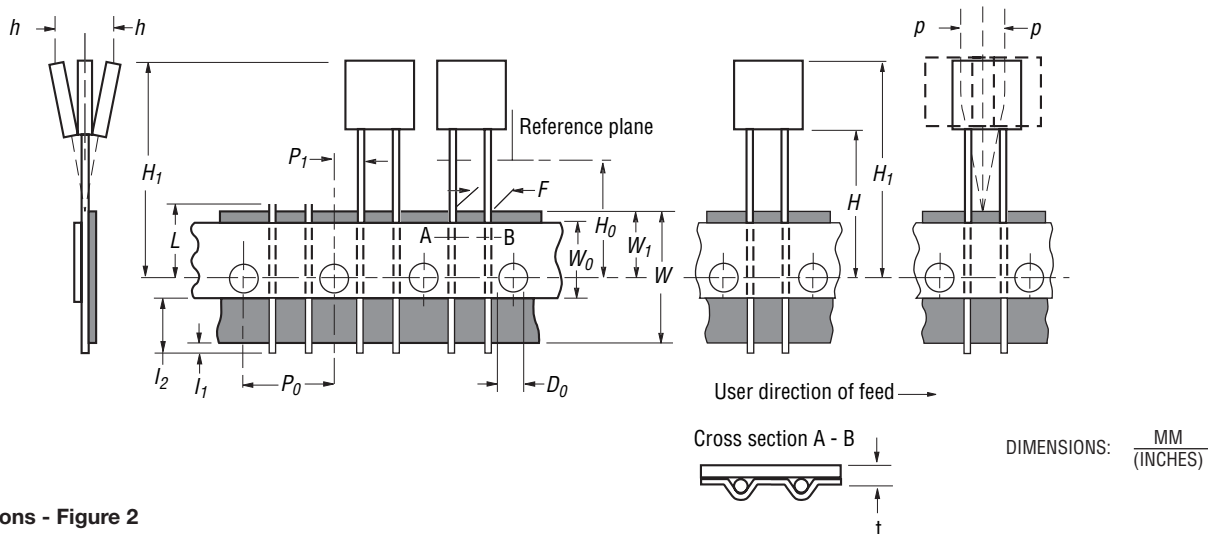

**Reel Dimensions - Figure 2**

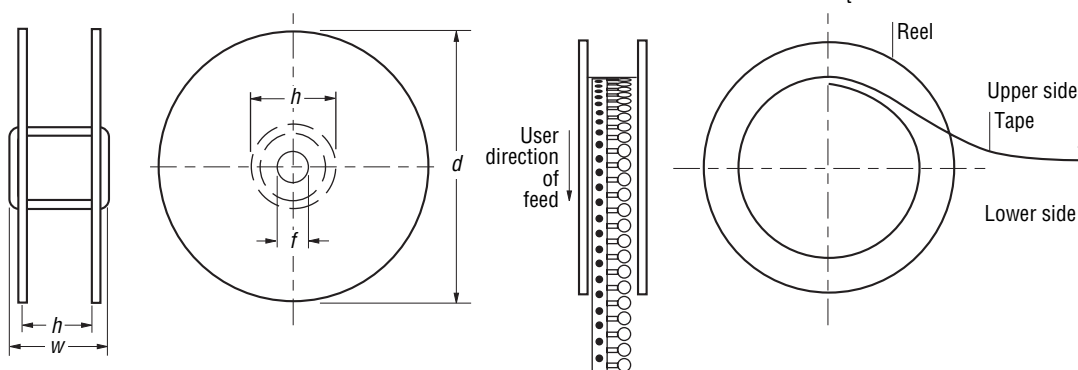

Specifications are subject to change without notice. Customers should verify actual device performance in their specific applications



Компания «ЭлектроПласт» предлагает заключение долгосрочных отношений при поставках импортных электронных компонентов на взаимовыгодных условиях!

Наши преимущества:

- Оперативные поставки широкого спектра электронных компонентов отечественного и импортного производства напрямую от производителей и с крупнейших мировых складов;
- Поставка более 17-ти миллионов наименований электронных компонентов;
- Поставка сложных, дефицитных, либо снятых с производства позиций;
- Оперативные сроки поставки под заказ (от 5 рабочих дней);
- Экспресс доставка в любую точку России;
- Техническая поддержка проекта, помощь в подборе аналогов, поставка прототипов;
- Система менеджмента качества сертифицирована по Международному стандарту ISO 9001;
- Лицензия ФСБ на осуществление работ с использованием сведений, составляющих государственную тайну;
- Поставка специализированных компонентов (Xilinx, Altera, Analog Devices, Intersil, Interpoint, Microsemi, Aeroflex, Peregrine, Syfer, Eurofarad, Texas Instrument, Miteq, Cobham, E2V, MA-COM, Hittite, Mini-Circuits, General Dynamics и др.);

Помимо этого, одним из направлений компании «ЭлектроПласт» является направление «Источники питания». Мы предлагаем Вам помощь Конструкторского отдела:

- Подбор оптимального решения, техническое обоснование при выборе компонента;
- Подбор аналогов;
- Консультации по применению компонента;
- Поставка образцов и прототипов;
- Техническая поддержка проекта;
- Защита от снятия компонента с производства.



#### Как с нами связаться

**Телефон:** 8 (812) 309 58 32 (многоканальный)

**Факс:** 8 (812) 320-02-42

**Электронная почта:** [org@eplast1.ru](mailto:org@eplast1.ru)

**Адрес:** 198099, г. Санкт-Петербург, ул. Калинина, дом 2, корпус 4, литера А.