

# USB 2.0 Hi-Speed 2-of-4 Crosspoint Switch

## General Description

The MAX4989 is a bidirectional 2-of-4 USB 2.0 crosspoint switch. The MAX4989 features the low on-capacitance and low on-resistance necessary to switch USB 2.0 low-/full-/Hi-Speed signals at data rates up to 480Mbps. This device allows any 2-of-4 USB pairs to be connected together and is configured through a simple 3-input control logic interface.

The MAX4989 operates from a single +2.7V to +5.5V supply and features an internal charge pump to permit full rail-to-rail swing. This device also features a high-impedance shutdown mode to reduce supply current to 100nA (typ).

The MAX4989 is available in a 14-pin, 3mm x 3mm TDFN package and operates over the extended -40°C to +85°C temperature range.

## Applications

Notebook Computers  
Cell Phones

## Features

- ◆ Single +2.7V to +5.5V Supply Voltage
- ◆ Low 1µA (typ) Supply Current
- ◆ -3dB Bandwidth: 1GHz (typ)
- ◆ Low 5Ω (typ) RON
- ◆ High-Impedance Shutdown Mode
- ◆ Logic Inputs Control Signal Routing
- ◆ +1.8V CMOS-Logic Compatible
- ◆ Ultra-Small 14-Pin, 3mm x 3mm, TDFN Package

## Ordering Information

PART	TEMP RANGE	PIN-PACKAGE	PKG CODE
MAX4989ETD+	-40°C to +85°C	14 TDFN-EP* (3mm x 3mm)	T1433-2

+ Denotes a lead-free/RoHS-compliant package.

\*EP = Exposed pad.

## Pin Configuration

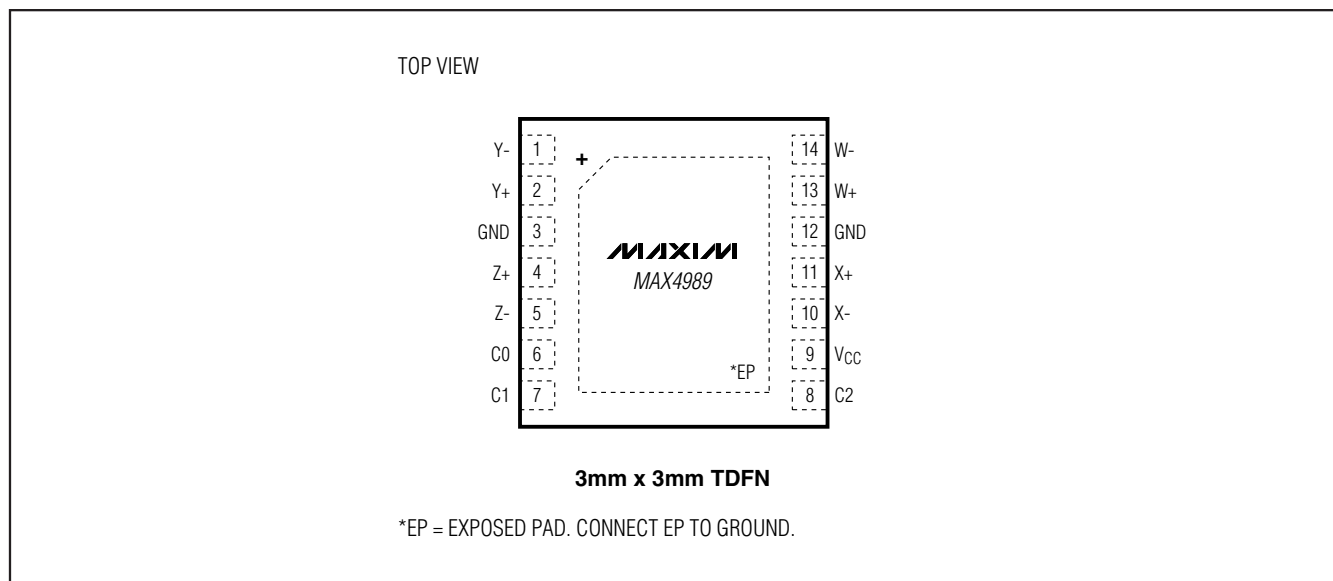

# USB 2.0 Hi-Speed 2-of-4 Crosspoint Switch

## ABSOLUTE MAXIMUM RATINGS

(Voltages referenced to GND.)

V <sub>CC</sub> .....	-0.3V to +6.0V
C <sub>-</sub> .....	-0.3V to +6.0V
W <sub>-</sub> , X <sub>-</sub> , Y <sub>-</sub> , Z <sub>-</sub> .....	-0.3V to (V <sub>CC</sub> + 0.3V)
Continuous Current C <sub>-</sub> .....	±30mA
Continuous Current W <sub>-</sub> , X <sub>-</sub> , Y <sub>-</sub> , Z <sub>-</sub> .....	±120mA
Peak Current W <sub>-</sub> , X <sub>-</sub> , Y <sub>-</sub> , Z <sub>-</sub> (pulsed at 1ms, 10% duty cycle).....	±240mA
Continuous Power Dissipation (T <sub>A</sub> = +70°C) 14-Pin TDFN (derate 24.4mW/°C above +70°C).....	1951mW

Junction-to-Case Thermal Resistance (θ<sub>JC</sub>) (Note 1)

14-Pin TDFN .....	8°C/W
-------------------	-------

Junction-to-Ambient Thermal Resistance (θ<sub>JA</sub>) (Note 1)

14-Pin TDFN .....	41°C/W
-------------------	--------

Operating Temperature Range .....

Junction Temperature .....

Storage Temperature Range .....

Lead Temperature (soldering, 10s) .....

**Note 1:** Package thermal resistances were obtained using the method described in JEDEC specification JESD51-7, using a 4-layer board. For detailed information on package thermal considerations, refer to [www.maxim-ic.com/thermal-tutorial](http://www.maxim-ic.com/thermal-tutorial).

Stresses beyond those listed under "Absolute Maximum Ratings" may cause permanent damage to the device. These are stress ratings only, and functional operation of the device at these or any other conditions beyond those indicated in the operational sections of the specifications is not implied. Exposure to absolute maximum rating conditions for extended periods may affect device reliability.

## ELECTRICAL CHARACTERISTICS

(V<sub>CC</sub> = +2.7V to +5.5V, T<sub>A</sub> = -40°C to +85°C, unless otherwise noted. Typical values are at V<sub>CC</sub> = +3.3V, T<sub>A</sub> = +25°C.) (Note 2)

PARAMETER	SYMBOL	CONDITIONS	MIN	TYP	MAX	UNITS
Operating Power-Supply Range	V <sub>CC</sub>		2.7		5.5	V
Supply Current	I <sub>CC</sub>	Switch enabled	V <sub>CC</sub> = +3.3V	1	3.5	μA
			V <sub>CC</sub> = +5.5V	3	6.5	
Shutdown Supply Current	I <sub>SHDN</sub>	C1 = C2 = C3 = GND or V <sub>CC</sub>		0.1	0.5	μA
Analog Signal Range	V <sub>W-</sub> , V <sub>X-</sub> , V <sub>Y-</sub> , V <sub>Z-</sub>		0		V <sub>CC</sub>	V
On-Resistance	R <sub>ON</sub>	V <sub>IN</sub> = +3.0V, I <sub>OUT</sub> = 10mA (Note 3)		5	9	Ω
On-Resistance Match Between Channels	ΔR <sub>ON</sub>	V <sub>CC</sub> = +3.3V, V <sub>IN</sub> = +1.5V, I <sub>OUT</sub> = 10mA (Note 3)		0.5		Ω
On-Resistance Flatness	R <sub>FLAT</sub>	V <sub>CC</sub> = +3.3V, V <sub>IN</sub> = 0V to V <sub>CC</sub> , I <sub>OUT</sub> = 10mA (Notes 3, 4, 5)		0.4		Ω
Off-Leakage Current	I <sub>IN(OFF)</sub>	V <sub>CC</sub> = +5.5V, V <sub>IN</sub> = 0V or V <sub>CC</sub> , V <sub>OUT</sub> = V <sub>CC</sub> or 0V or unconnected (Note 3)	-1		+1	μA
On-Leakage Current	I <sub>IN(ON)</sub>	V <sub>CC</sub> = +5.5V, V <sub>IN</sub> = 0V or V <sub>CC</sub> , V <sub>OUT</sub> = unconnected (Note 3)	-1		+1	μA
<b>AC PERFORMANCE (Note 4)</b>						
On-Channel -3dB Bandwidth	BW	R <sub>L</sub> = R <sub>S</sub> = 50Ω, V <sub>IN</sub> = 0dBm, Figure 1		1		GHz
Insertion Loss	S <sub>12</sub>	R <sub>L</sub> = R <sub>S</sub> = 50Ω, f = 10MHz		0.5		dB
Off-Isolation (Note 3) Figure 1	V <sub>ISO</sub>	f = 10MHz, V <sub>IN</sub> = 0dBm, R <sub>L</sub> = R <sub>S</sub> = 50Ω		-43		dB
		f = 250MHz, V <sub>IN</sub> = 0dBm, R <sub>L</sub> = R <sub>S</sub> = 50Ω		-15		
Crosstalk	V <sub>CT</sub>	f = 50MHz, V <sub>IN</sub> = 0dBm, R <sub>L</sub> = R <sub>S</sub> = 50Ω, between adjacent pairs (Note 3), Figure 1		-50		dB

# USB 2.0 Hi-Speed 2-of-4 Crosspoint Switch

MAX4989

## ELECTRICAL CHARACTERISTICS (continued)

( $V_{CC} = +2.7V$  to  $+5.5V$ ,  $T_A = -40^{\circ}C$  to  $+85^{\circ}C$ , unless otherwise noted. Typical values are at  $V_{CC} = +3.3V$ ,  $T_A = +25^{\circ}C$ .) (Note 2)

PARAMETER	SYMBOL	CONDITIONS	MIN	TYP	MAX	UNITS
<b>DYNAMIC (Note 4)</b>						
Turn-On Time	$t_{ON}$	$V_{IN} = +1.5V$ , $R_L = 300\Omega$ , $C_L = 35pF$ , $V_{C\_} = 0V$ to $V_{CC}$ , Figure 2		15	100	$\mu s$
Turn-Off Time	$t_{OFF}$	$V_{IN} = +1.5V$ , $R_L = 300\Omega$ , $C_L = 35pF$ , $V_{C\_} = 0V$ to $V_{CC}$ , Figure 2		2	6	$\mu s$
Propagation Delay	$t_{PLH}$ , $t_{PHL}$	$R_L = R_S = 50\Omega$ , Figure 3		120		ps
Output Skew Between Switches	$t_{SK(O)}$	$R_L = R_S = 50\Omega$ , Figure 3		50		ps
Output Skew Same Switch	$t_{SK(P)}$	$R_L = R_S = 50\Omega$ , Figure 3		50		ps
Off-Capacitance	$C_{OFF}$	$f = 1MHz$ , $V_{BIAS} = 0V$ , $V_{IN} = 0.5V_{P-P}$		13.5		pF
		$f$ at $-3dB = 240MHz$ , $V_{BIAS} = 0V$ , $V_{IN} = 0.5V_{P-P}$		4		
On-Capacitance	$C_{ON}$	$f = 1MHz$ , $V_{BIAS} = 0V$ , $V_{IN} = 0.5V_{P-P}$		6		pF
		$f$ at $-3dB = 240MHz$ , $V_{BIAS} = 0V$ , $V_{IN} = 0.5V_{P-P}$				
<b>LOGIC INPUTS</b>						
Input Logic High	$V_{IH}$		1.7			V
Input Logic Low	$V_{IL}$				0.5	V
Input Logic Hysteresis	$V_{HYST}$			75		mV
Input Leakage Current	$I_{IN}$	$V_{CC} = +5.5V$ , $V_{C\_} = GND$ or $V_{CC}$	-1		+1	$\mu A$

**Note 2:** All devices are 100% production tested at  $T_A = +25^{\circ}C$ . All temperature limits are guaranteed by design.

**Note 3:** IN and OUT refer to input and output terminals (W\_, X\_, Y\_, Z\_) of any switch configuration.

**Note 4:** Not production tested. Guaranteed by design.

**Note 5:** Flatness is defined as the difference between the maximum and minimum value of on-resistance, as measured over specified analog signal ranges.

# USB 2.0 Hi-Speed 2-of-4 Crosspoint Switch

## Test Circuits/Timing Diagrams

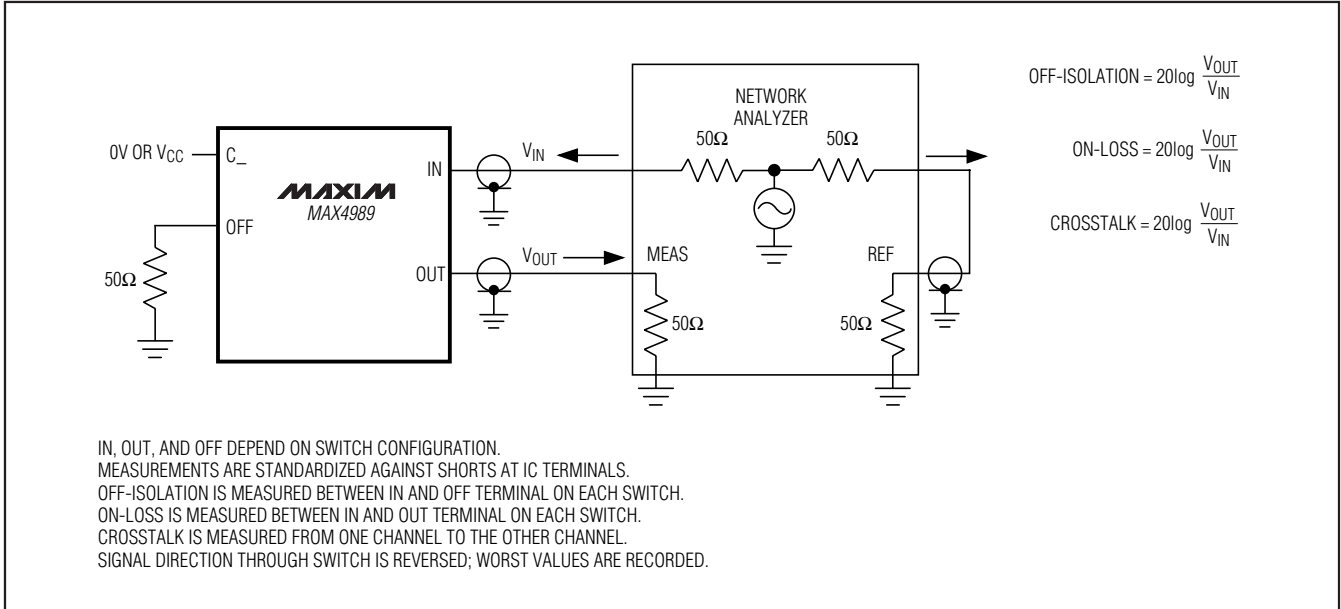

Figure 1. On-Loss, Off-Isolation, and Crosstalk

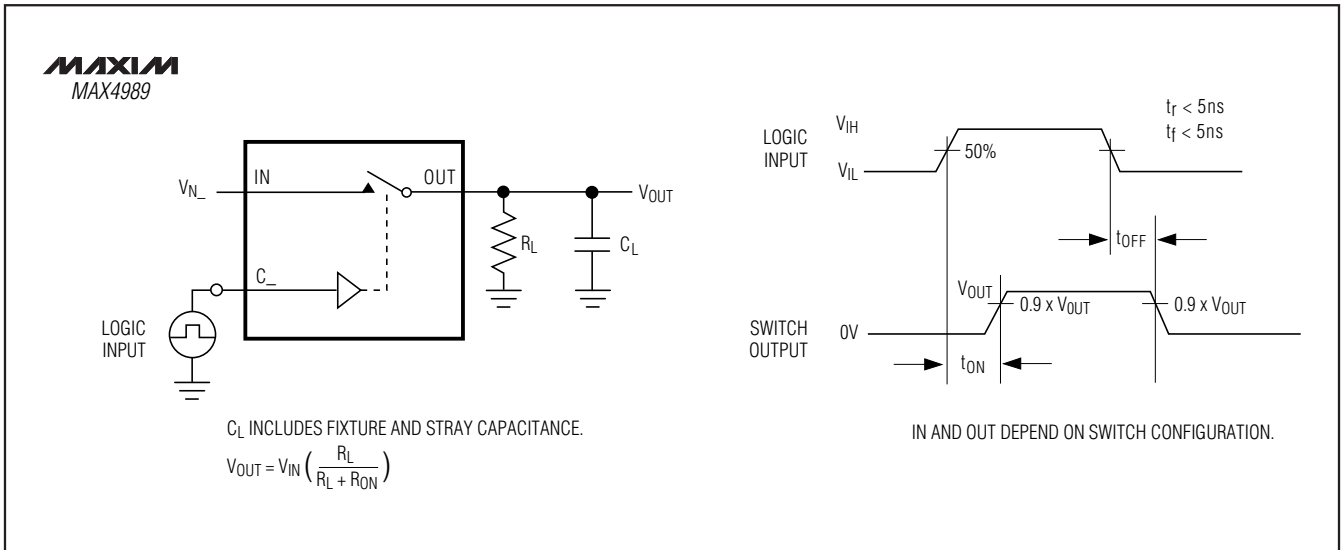

Figure 2. Switching Time

# USB 2.0 Hi-Speed 2-of-4 Crosspoint Switch

## Test Circuits/Timing Diagrams (continued)

MAX4989

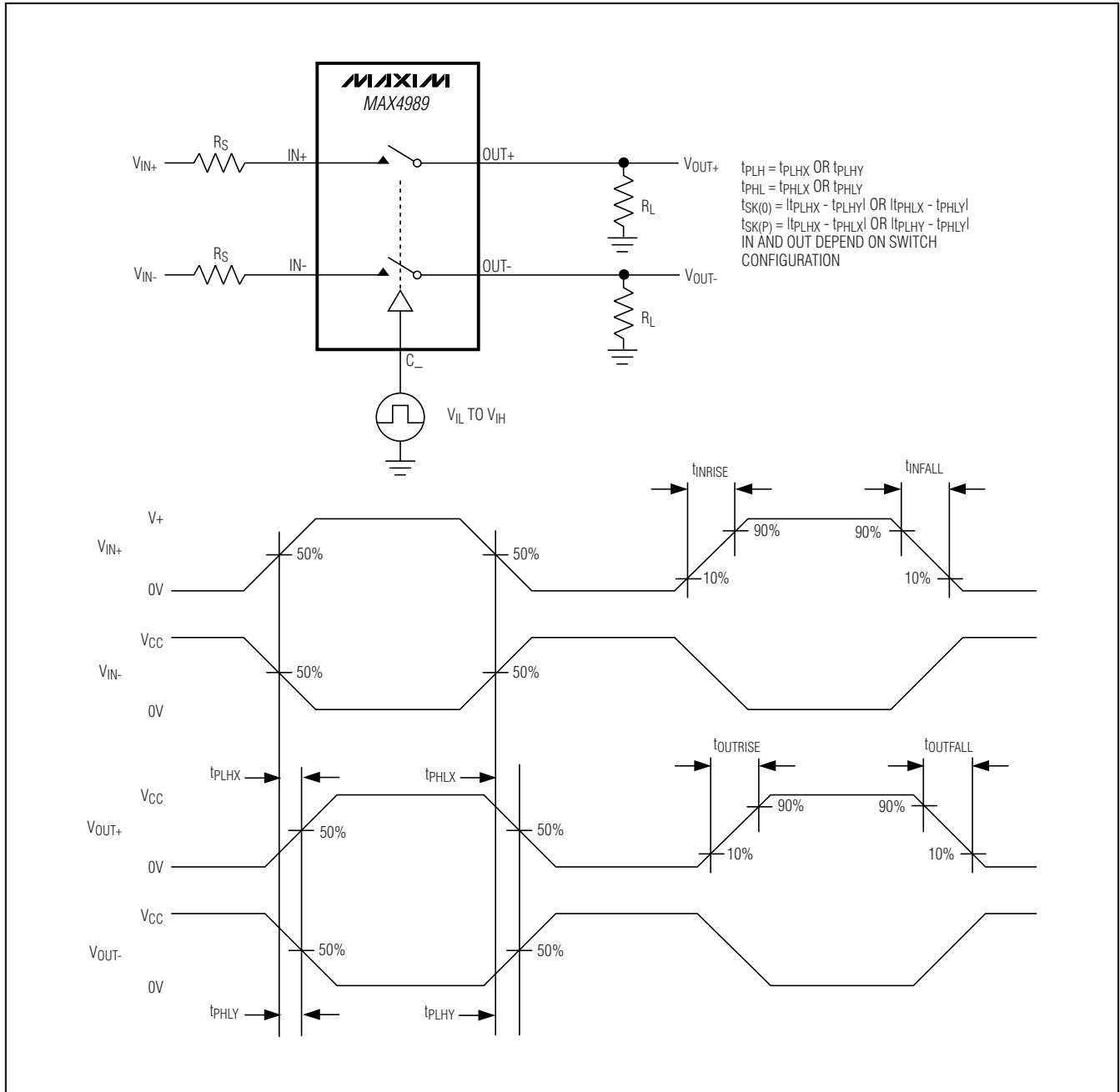
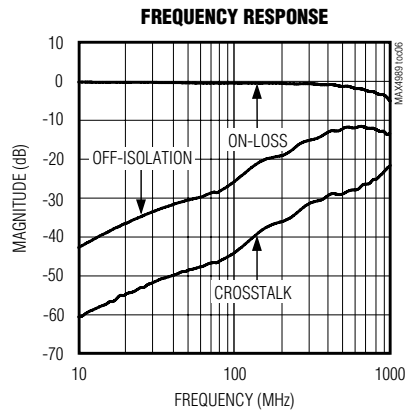
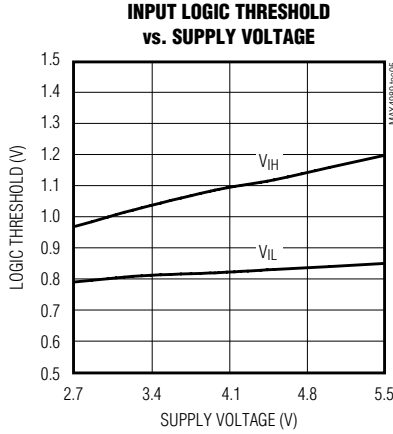
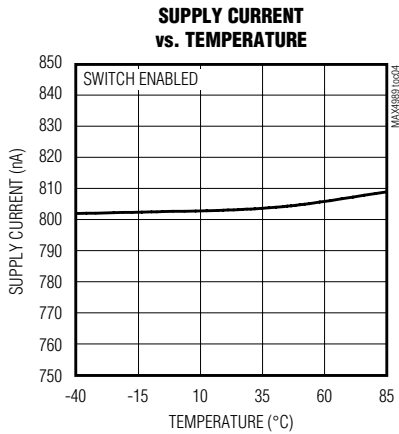
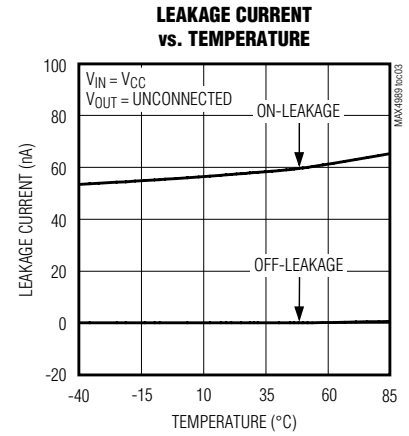
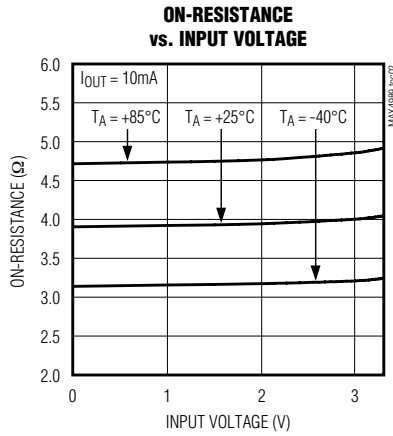
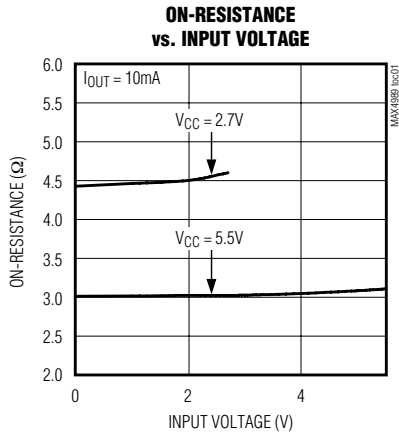

Figure 3. Output Signal Skew, Rise/Fall Time, Propagation Delay

# USB 2.0 Hi-Speed 2-of-4 Crosspoint Switch

## Typical Operating Characteristics

( $V_{CC} = +3.3V$ ,  $T_A = +25^\circ C$ , unless otherwise noted.)



# USB 2.0 Hi-Speed 2-of-4 Crosspoint Switch

MAX4989

## Pin Descriptions

PIN	NAME	FUNCTION
1	Y-	Inverting Input/Output of Terminal Y
2	Y+	Noninverting Input/Output of Terminal Y
3	GND	Ground
4	Z+	Noninverting Input/Output of Terminal Z
5	Z-	Inverting Input/Output of Terminal Z
6	C0	Control Input 0
7	C1	Control Input 1
8	C2	Control Input 2
9	VCC	Positive Supply Voltage Input. Bypass VCC to GND with a 0.1 $\mu$ F ceramic capacitor as close as possible to the device.
10	X-	Inverting Input/Output of Terminal X
11	X+	Noninverting Input/Output of Terminal X
12	GND	Ground
13	W+	Noninverting Input/Output of Terminal W
14	W-	Inverting Input/Output of Terminal W
—	EP	Exposed Pad. EP can be connected to GND or left unconnected. EP is not intended as an electrical connection point.

## Detailed Description

The MAX4989 is a USB 2.0 bidirectional crosspoint switch that allows the user to connect any 2 of 4 USB pairs. The device operates from a single +2.7V to +5.5V supply and features an internal charge pump to permit the full rail-to-rail swing necessary for USB low-/full-/Hi-Speed applications with data rates up to 480Mbps.

### Control Logic Inputs

The MAX4989 provides three control logic inputs, C0, C1, and C2, to control the switch connections as shown in the *Functional Diagram/Truth Table*. Driving the control logic inputs rail-to-rail minimizes power consumption.

### Shutdown Mode

The MAX4989 features a shutdown mode that reduces the supply current to less than 0.5 $\mu$ A and places all switch terminals in high impedance. Drive all control inputs high or all control inputs low to place the device in shutdown mode (see *Functional Diagram/Truth Table*.)

## USB Switching

The low on-resistance and low on-capacitance of the MAX4989 make it ideal for high-performance Hi-Speed USB 2.0 switching applications. The MAX4989 is ideal for routing USB data lines and for applications that require switching between multiple USB hosts or devices (Figure 4).

### Layout

Hi-Speed USB requires careful PCB layout with controlled-impedance matched traces of equal lengths. Ensure that bypass capacitors are as close as possible to the device. Use large ground planes where possible.

### Power-Supply Sequencing

**Caution: Do not exceed the absolute maximum ratings because stresses beyond the listed ratings may cause permanent damage to the device.**

Proper power-supply sequencing is recommended for all devices. Always apply VCC before applying signals, especially if the signal is not current limited.

## Chip Information

PROCESS: BiCMOS

# USB 2.0 Hi-Speed 2-of-4 Crosspoint Switch

## Functional Diagram/Truth Table

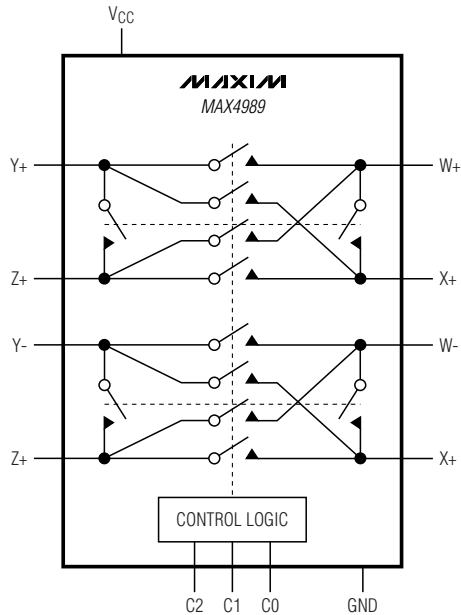

MAX4989			
C2	C1	C0	SWITCH
0	0	0	SHUTDOWN
0	0	1	W AND X CONNECTED
0	1	0	W AND Y CONNECTED
0	1	1	W AND Z CONNECTED
1	0	0	X AND Z CONNECTED
1	0	1	X AND Y CONNECTED
1	1	0	Y AND Z CONNECTED
1	1	1	SHUTDOWN

## Applications Information

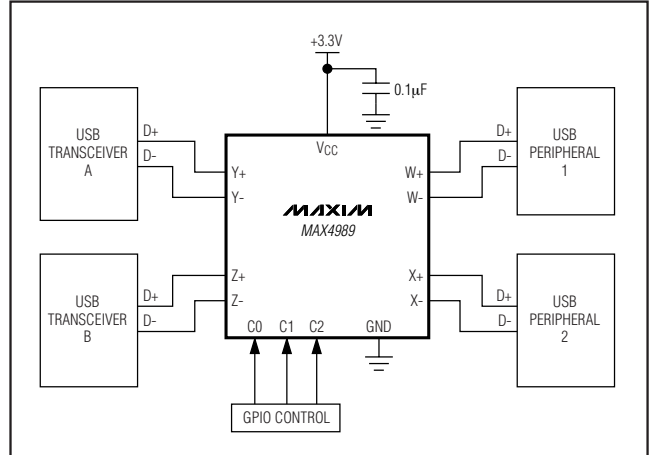

Figure 4. Typical Application Circuit

## Package Information

For the latest package outline information and land patterns, go to [www.maxim-ic.com/packages](http://www.maxim-ic.com/packages).

PACKAGE TYPE	PACKAGE CODE	DOCUMENT NO.
14 TDFN	T1433-2	<a href="#">21-0137</a>

Maxim cannot assume responsibility for use of any circuitry other than circuitry entirely embodied in a Maxim product. No circuit patent licenses are implied. Maxim reserves the right to change the circuitry and specifications without notice at any time.

8 Maxim Integrated Products, 120 San Gabriel Drive, Sunnyvale, CA 94086 408-737-7600





Компания «ЭлектроПласт» предлагает заключение долгосрочных отношений при поставках импортных электронных компонентов на взаимовыгодных условиях!

Наши преимущества:

- Оперативные поставки широкого спектра электронных компонентов отечественного и импортного производства напрямую от производителей и с крупнейших мировых складов;
- Поставка более 17-ти миллионов наименований электронных компонентов;
- Поставка сложных, дефицитных, либо снятых с производства позиций;
- Оперативные сроки поставки под заказ (от 5 рабочих дней);
- Экспресс доставка в любую точку России;
- Техническая поддержка проекта, помощь в подборе аналогов, поставка прототипов;
- Система менеджмента качества сертифицирована по Международному стандарту ISO 9001;
- Лицензия ФСБ на осуществление работ с использованием сведений, составляющих государственную тайну;
- Поставка специализированных компонентов (Xilinx, Altera, Analog Devices, Intersil, Interpoint, Microsemi, Aeroflex, Peregrine, Syfer, Eurofarad, Texas Instrument, Miteq, Cobham, E2V, MA-COM, Hittite, Mini-Circuits, General Dynamics и др.);

Помимо этого, одним из направлений компании «ЭлектроПласт» является направление «Источники питания». Мы предлагаем Вам помощь Конструкторского отдела:

- Подбор оптимального решения, техническое обоснование при выборе компонента;
- Подбор аналогов;
- Консультации по применению компонента;
- Поставка образцов и прототипов;
- Техническая поддержка проекта;
- Защита от снятия компонента с производства.



#### Как с нами связаться

**Телефон:** 8 (812) 309 58 32 (многоканальный)

**Факс:** 8 (812) 320-02-42

**Электронная почта:** [org@eplast1.ru](mailto:org@eplast1.ru)

**Адрес:** 198099, г. Санкт-Петербург, ул. Калинина, дом 2, корпус 4, литера А.