

TPC-1881WPH

18.5 FHD TFT LED LCD Intel® 4th Generation Core i5 Multi-Touch Panel Computer

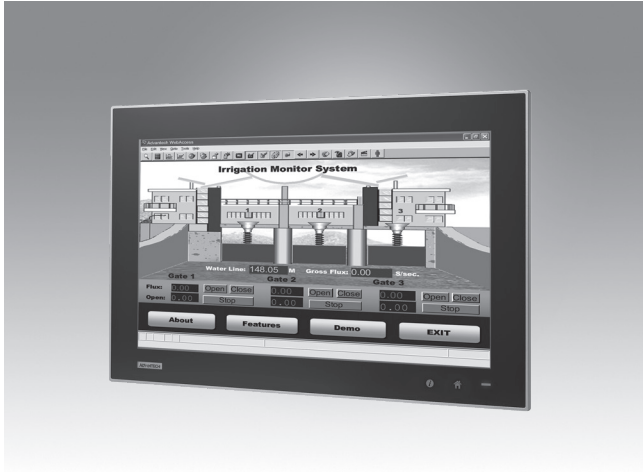

Features

- Industrial 18.5 FHD TFT LCD with 50K Lifetime LED Backlight
- Intel 4th Generation Core i5 4300U with 4GB/8GB DDR3L SDRAM
- 16:9 Wide Screen with PCT Multi-Touch
- IP66 Approved Front Protection & Panel Mounting
- Built-in Intelligent Home key and i Key for Intuitive UI
- Front LED Indicator to Show Operating Status
- Diverse system IO and Isolated Digital IO by iDoor Technology
- Supports Fieldbus Protocol by iDoor Technology
- 3G/GPS/GPRS/WiFi Communication by iDoor Technology
- Supports Battery-backup MRAM by iDoor Technology
- Chassis Grounding Protection
- HDMI and Audio Multimedia Support
- Certified with UL CID2 for hazardous environments

Introduction

With growing up in Multi-Touch technology, the TPC-1881WPH features Intel 4th Generation Core i5-4300U 1.9GHz processor with 4GB/8GB DDR3L SDRAM provides the high computing performance. Moreover, it is designed to be safely operated for a variety of industry application certified with UL Class I Division 2 for hazardous environments. Through the Mini-PCIe slot, Advantech iDoor technology can provide more I/O connectors, Isolated Digital IO, the Fieldbus Protocol, 3G/GPS/GPRS/WiFi Communication and Battery-backup MRAM. A 2nd monitor and speaker can be attached via the integrated HDMI and Audio port.

Specifications

General

- BIOS** AMI UEFI
- Certification** BSMI, CCC, CE, FCC Class A, UL C1D2
- Cooling System** Fanless design
- Dimensions (W x H x D)** 488 x 309 x 56.7 mm (19.21" x 12.17" x 2.23")
- Enclosure** Front bezel: Die cast aluminum alloy
Back housing: PC/ABS resin
- Mounting** Panel Mount
- OS Support** Microsoft® Windows WES7 (32/64-bit), WE8S (64-bit), Windows 7 (32/64-bit), Windows 8 (64-bit), Ubuntu 14.04.2 LTS, Windows 10 IoT Enterprise LTSC 28W Typical, 60W Max. (Without Add-on card)
- Power Consumption** 28W Typical, 60W Max. (Without Add-on card)
- Power Input** 24V_{DC} +/- 20%
- Watchdog Timer** 1 ~ 255 sec (system)
- Weight (Net)** 7kg (15.44 lbs)

System Hardware

- CPU** Intel 4th Generation Core i5-4300U 1.9GHz
- Chipset** Lynx Point-LP
- Memory** 4GB DDR3L 1600MHz SO-DIMM SDRAM (up to 8GB)
- LAN** 10/100/1000BASE-T x 2 (one port supports iAMT)
- Expansion Slots** Pull-size mini PCIe
- Storage** CFast slot x 1
2.5" SATA SSD slot x 1
- I/O** RS-232 x 1, RS-232/422/485 x 1
USB 3.0 x 2, HDMI 1.4 x 1
Audio line out x 1, USB 2.0 x 1 (optional)
Audio MIC x 1 (optional)

LCD Display

- Display Type** HD TFT LED LCD
- Display Size** 18.5
- Max. Resolution** 1920 x 1080
- Max. Colors** 16.7M
- Luminance cd/m²** 350
- Viewing Angle (H/V°)** 170/160
- Backlight Life** 50,000 hr
- Contrast Ratio** 1000:1

Touchscreen

- Light Transmission** ≥88%
- Resolution** 4096 x 4096 dot
- Type** Projected capacitive

Environment

- Humidity** 10 ~ 95% RH @ 40°C, non-condensing
- Ingress Protection** Front panel: IP66
- Operating Temperature** 0 ~ 55°C (32 ~ 131°F)
- Storage Temperature** -20 ~ 60°C (-4 ~ 140°F)
- Vibration Protection** With HDD: 1 Grms (5 ~ 500 Hz) (Operating, random vibration)

Rear View

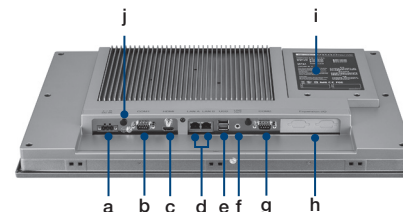

- a. 24V_{DC} Power
- b. COM Port RS-232
- c. HDMI
- d. GbE
- e. USB 3.0
- f. Audio Line out
(Line out port using cable ties for suitable mechanical secured is accepted.)
- g. COM Port RS-232/422/485
- h. Expansion I/O (iDoor)
- i. 2.5" SATA SSD, CFast and Mini PCIe Slot
- j. SMA Connector for Antenna

Dimensions

Unit: mm [inch]

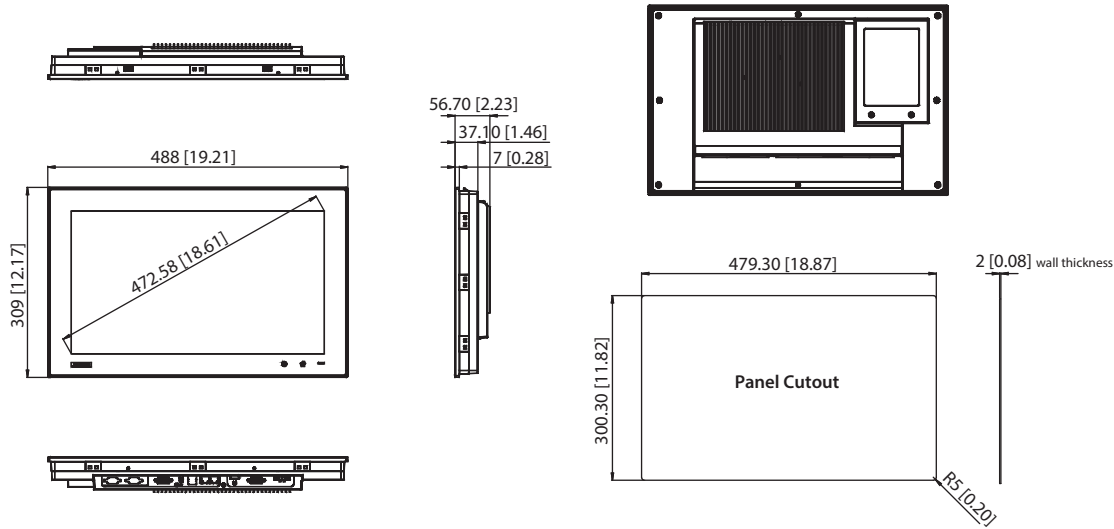

Panel Cutout Dimensions: 479.3 x 300.3 (18.87" x 11.82")

Ordering Information

- **TPC-1881WPH-453AE** 18.5" widescreen PCT with i5, 4G RAM, C1D2

Optional Accessories

- **96PSA-A150W24T2** Adapter 100-240V 150W 24V
- **1702002600** Power Cable US Plug 1.8 M
- **1702002605** Power cable EU Plug 1.8M
- **1702031801** Power cable UK Plug 1.8M
- **1700000596-11** Power Cable China/Australia Plug 1.8 M
- **EWM-W151H01E** 802.11bgn RTL8188EE 1T1R, Half-size mini PCIe (also need 9656EWMG00E)
- **9656EWMG00E** Half-size miniPCIe to Full-size miniPCIe bracket set
- **1750000318** EMI Antenna 2DBI 2.4GHz SMA CONN for ARK-3384
- **1750003222** 802.11b/g 5dBi Dipole Antenna
- **1750003418** Wireless Antenna AN2400-5901RS R/P SMA.M9dB

Embedded O/S

- **2070013889** TPC-xx81WP WS7P x86 MUI Image v4.13
- **2070013489** TPC-xx81WP WS7P x64 MUI Image v4.12
- **2070014320** TPC-1881WR WS7P X64 MUI Image V4.14
- **2070014920** TPC-1881WP-433AE WIN10ENT LTSB Image
- **2070014921** TPC-1881WP-473AE WIN10ENT LTSB Image

iDoor Modules

- **PCM-2300MR-AE** MR4A16B, 2MByte
- **PCM-26D1PB-AE** Hilscher netX100 FieldBus, ProfiBus, DB9 x 1
- **PCM-26D2CA-AE** SJA1000 CANBus, CANOpen, DB9 x 1
- **PCM-24D2R4-AE** OXPcIe-952 UART, Isolated RS-422/485, DB9 x 2
- **PCM-24D2R2-AE** OXPcIe-952 UART, Isolated RS-232, DB9 x 2
- **PCM-24D4R4-AE** OXPcIe-954 UART, Non-Isolated RS-422/485, DB37 x 1
- **PCM-24D4R2-AE** OXPcIe-954, UART, Non-Isolated RS-232, DB37 x 1
- **PCM-27D24DI-AE** Digital I/O, 16DI / 8DO, DB37 x 1

Application Software

<p>WebAccess/SCADA</p>	<p>Advantech WebAccess is a 100% web based SCADA (Supervisory Control And Data Acquisition) software and it acts as an IIoT Platform providing open interfaces for partners to develop IoT applications for different vertical markets. In addition to traditional SCADA functions, WebAccess has an intelligent Dashboard, to provide users with cross-platform, cross-browser data analysis and user interface using HTML5 technology. As well as the built-in widgets, WebAccess also provides Widget Builder to allow customers to build their own.</p>
<p>WebAccess/HMI</p>	<p>WebAccess/HMI is Human Machine Interface (HMI) software based on Microsoft's Windows operating system. It utilizes a PC's ample resources, ie speed, storage, multimedia, peripheral devices, and large screen to produce a complex human-machine interface. WebAccess/HM with its communication and monitoring ability supports more than 350 PLC communication protocols and a wide choice of screen design objects, to satisfy multiple integrations of factory automation and all-round human-machine interface operation and monitoring requirements.</p>
	<p>The Codesys application-ready-package offering which includes PC-based Panel Controller with multi-touch panel, high performance Intel Core-i multi-core processor, SSD, 2MB MRAM, Microsoft Windows embedded 7 Pro and CODESYS Control Runtime & Visualization. This allows users to easily achieve an open control solution, the PC-based real-time control system, enabling real-time PLC or PLC/Softmotion control with flexible Fieldbus options such as PROFINET, EtherCAT, EtherNet/IP, CANopen, Modbus TCP/RTU and providing the on-site visualized HMI operation. The software/hardware flexibility and stability of PC-based Cabinet Controller is able to fulfill various control applications in vertical industries.</p>



Компания «ЭлектроПласт» предлагает заключение долгосрочных отношений при поставках импортных электронных компонентов на взаимовыгодных условиях!

Наши преимущества:

- Оперативные поставки широкого спектра электронных компонентов отечественного и импортного производства напрямую от производителей и с крупнейших мировых складов;
- Поставка более 17-ти миллионов наименований электронных компонентов;
- Поставка сложных, дефицитных, либо снятых с производства позиций;
- Оперативные сроки поставки под заказ (от 5 рабочих дней);
- Экспресс доставка в любую точку России;
- Техническая поддержка проекта, помощь в подборе аналогов, поставка прототипов;
- Система менеджмента качества сертифицирована по Международному стандарту ISO 9001;
- Лицензия ФСБ на осуществление работ с использованием сведений, составляющих государственную тайну;
- Поставка специализированных компонентов (Xilinx, Altera, Analog Devices, Intersil, Interpoint, Microsemi, Aeroflex, Peregrine, Syfer, Eurofarad, Texas Instrument, Miteq, Cobham, E2V, MA-COM, Hittite, Mini-Circuits, General Dynamics и др.);

Помимо этого, одним из направлений компании «ЭлектроПласт» является направление «Источники питания». Мы предлагаем Вам помощь Конструкторского отдела:

- Подбор оптимального решения, техническое обоснование при выборе компонента;
- Подбор аналогов;
- Консультации по применению компонента;
- Поставка образцов и прототипов;
- Техническая поддержка проекта;
- Защита от снятия компонента с производства.



Как с нами связаться

Телефон: 8 (812) 309 58 32 (многоканальный)

Факс: 8 (812) 320-02-42

Электронная почта: org@eplast1.ru

Адрес: 198099, г. Санкт-Петербург, ул. Калинина, дом 2, корпус 4, литера А.