

High speed transmission, 1mm pitch Small Interface Connector

DH Series

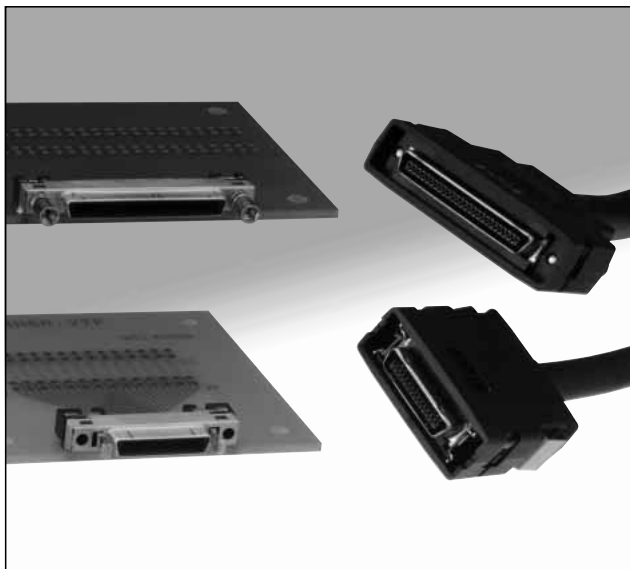

Overview

DH Series is an impedance controlled interface connector for high speed transmission.

1mm contact mating pitch together with a 0.5mm mounting pitch yields a more compact, lower profile, higher density alternate to conventional half pitch interface connectors. 4 different lock styles are available to meet various applications.

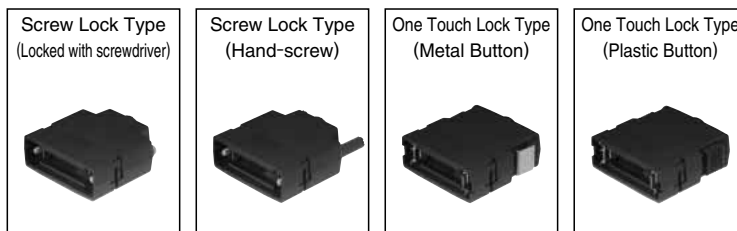

Features

1. Small Design

Mating face area
Approx 50% reduced

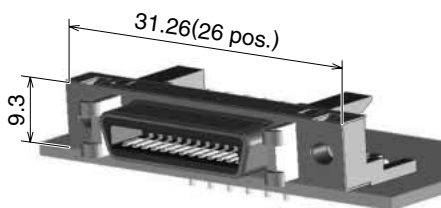
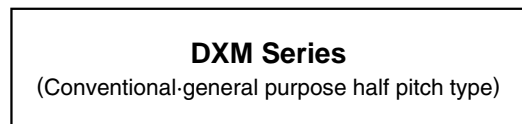

Mating pitch: 1.27mm

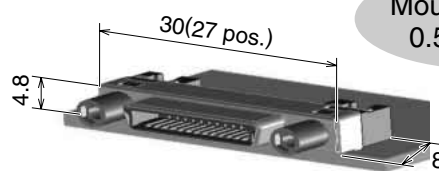
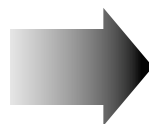

Mating pitch: 1.0mm

2. Robust design

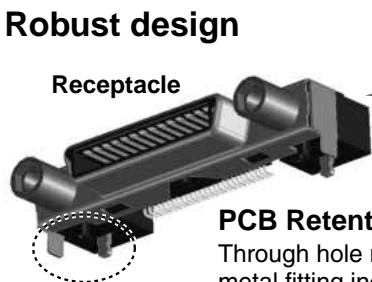

Robust design resists wrenching D-shaped opening.

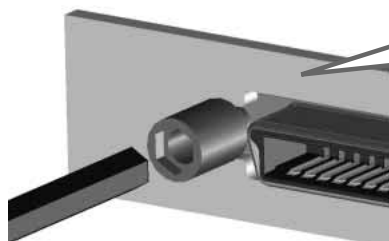

Robust & Secure Screw Lock
Tightening torque: 0.06 to 0.07 N·m max

3. Excellent Shielding for EMI Privention

◆Grounding Structure

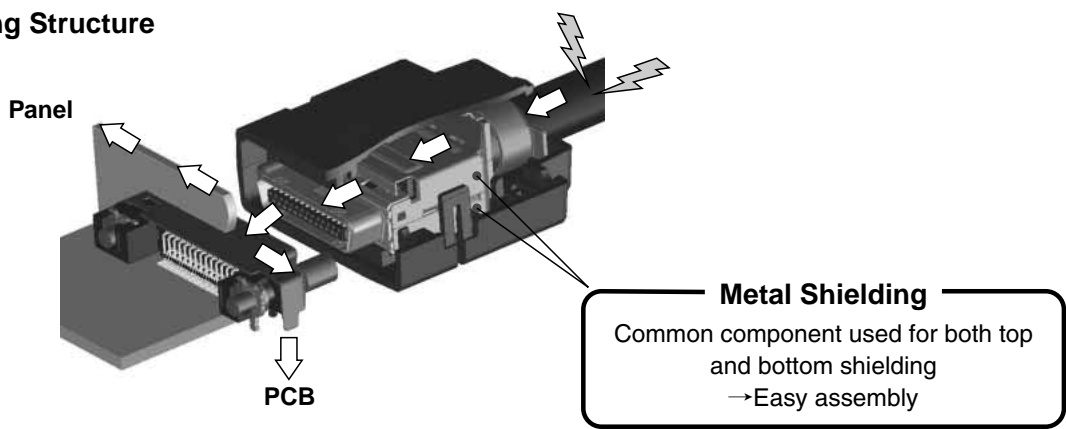

4. Wide variation

There are various variations corresponding to the usage.

●Lock variation

Lock type	Cover case	receptacle			
Item	Specification /Part number	Item	Part number		
Screw lock	Screwdriver type DH-**-CV1B Hand-screw type DH-**-CV2B	Connector	DH60-**P / DH80-**P		
		Panel lock	Applicable panel thickness(mm)	Number of washers	Part No.
			1.4 to 1.6	0	DH-LNA
			0.9 to 1.2	1(t=0.4)	DH-LNA-W4
0.5 to 0.8mm	1(t=0.6)		DH-LNA-W8		
No panel	1(t=0.8)	DH-LNA-W16			
One touch lock	Metal button DH-**-CT1B Plastic button DH-**-CT2B	Connector	DH60A-**P / DH80A-**P		

*Screw lock type and One touch lock type does not mate together.

●Common part

Lock type	Plug				No. of pos.	Clamp metal Part No.
	Connector Specification / Part number					
Screw lock	IDC type				17	DH-17-CMB(6.3)
	Cable spec.	Outer dia.	Construction	Part No.	27	DH-27-CMB(6.9) DH-27-CMB(7.3)
	Twinax cable	0.88 to 0.92	7/0.127	DH30B-**S		
	Twisted pair cable	0.64 to 0.68	(AWG#28)	DH32B-**S		
One touch lock	solder type DH40-**S (Developing Pin-variation of the above item is under planning.) Please consult HRS sales.)				37	DH-37-CMB(8.8)
					51	DH-51-CMB(9.6)

*The figure in () clamp part number is equal to the cable's outer diameter.

5. High Speed Data Transmission

This data is for reference only. The data can differ due to cable or PCB used in evaluation.

Eye Diagram [CH1-CH2]

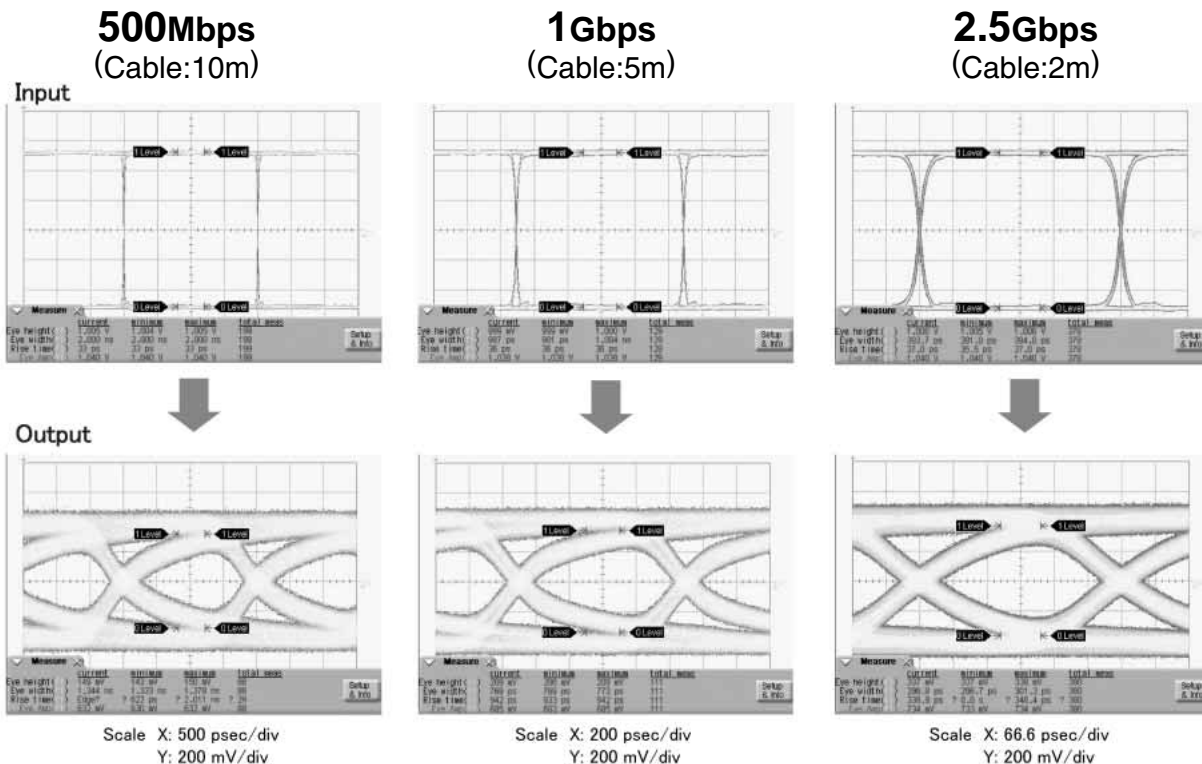

Measurement Condition

◆ Pin Assignment

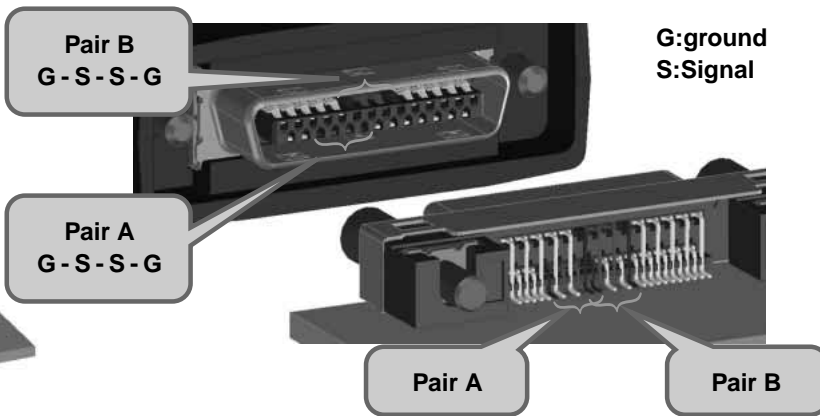

◆ Measurement Condition

- Measurement Pair:Deferential Pair A
- Cable:Twinax cable
- Input signal voltage:500mV

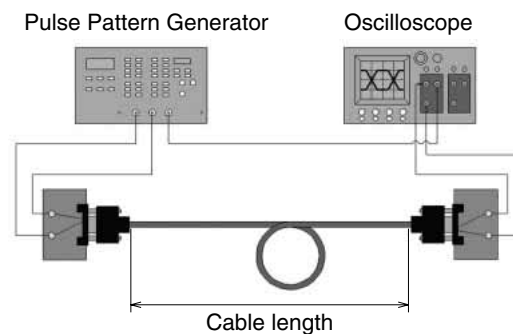

Specifications

Ratings	Current rating	0.5A				Operating temperature range	-25°C to +85°C
	Voltage rating	125 V AC				Storage temperature range	-25°C to +60°C
Item	Specification					Conditions	
1.Contact resistance	① 50mΩ max.(signal)					100mA(DC or 1,000Hz)	
2.Insulation resistance	1000MΩ min.					100 V DC	
3.Withstanding voltage	No flashover or insulation breakdown					250 V AC/1minute	
4.Insertion and with drawal forces		17pos.	27pos.	37pos.	51pos.	Measured by applicable connector.	
	Insertion f.	25N max.	30N max.	36N max.	43N max.		
	with drawal f.	2.6N min.	3N min.	3.3N min.	3.8N min.		
5.Durability	① Contact resistance:70mΩ max. ② No damage, cracks or parts dislocation.					1000 cycles	
6.Vibration	① No electrical discontinuity of 10μs or longer. ② No damage, cracks or parts dislocation.					Frequency:10 to 50Hz, single amplitude of 0.75mm, 5min/cycle, total 10 cycles.	
7.Shock						Acceleration of 490m/s ² , 11ms duration, sine half-wave waveform, 3 cycles in each of the 3 axis.	
8.Temperature cycle	① Contact resistance:70mΩ max. ② No damage, cracks or parts dislocation.					Temperature: -55°C→+5°C to +35°C→+85°C→+5°C to+35°C Time:30→5→30→5(Minutes) 5cycles	
9.Humidity (Steady state)	① Insulation resistance:100MΩmin. ② No damage, cracks or parts dislocation.					96 hours at 40°C And RH 90% to 95%.	
10.Salt spray test	① Contact resistance:100mΩ max.					5% salt water solution for 48 hours.	

① Excludes wire conductor resistance. *Unless otherwise specified, refer to JIS C 5402

② Information contained in this catalog represents general requirements for this Series. Contact us for the drawings and specifications for a specific part number shown.

Materials

Products	Components	Material	Finish	Remarks
Screw lock type receptacle connector (DH60-***P / DH80-***P)	Insulator	Polyamide resin	Black	UL94V-0
	Contacts	Copper alloy	Selective gold plated	—
	Shell	Stainless steel	Tin plated	—
	Metal fitting	Stainless steel	Selective Tin plated	—
One Touch Lock Type Receptacle connector (DH60A-***P / DH80A-***P)	Insulator	Polyamide resin	Black	UL94V-0
	Contacts	Copper alloy	selective gold plated	—
	Shell	Stainless steel	Tin plated	—
	Metal fitting	Brass	Tin plated	—
Plug connector (DH3*B-***S)	Metal grounding post	Steel	Nickel plated	—
	Insulator	Polyamide resin	Black	UL94V-0
	Contacts	Copper alloy	Selective gold plated	—
	Rear insert	PBT resin	Black,Natural	UL94V-0
Screw lock type cover case (DH-**-CV1B)	Shell	Stainless steel	Nickel plated	—
	Cover	Polycarbonate resin	Black	UL94V-0
	Shield	Stainless steel	Nickel plated	—
	Screw lock	Steel	Nickel plated	—
Lock type cover case (DH-**-CV2B)	Tapping screw	Steel	Black chromate(Cr+3)	—
	Cover	Polycarbonate resin	Black	UL94V-0
	Shield	Stainless steel	Nickel plated	—
	Screw lock	Steel	Nickel plated	—
One Touch Lock Type metal button cover case (DH-**-CT1B)	Screw insulator	Polyamide resin	Black	UL94V-0
	Tapping screw	Steel	Black chromate(Cr+3)	—
	Cover	Polycarbonate resin	Black	UL94V-0
	Shield	Stainless steel	Nickel plated	—
One Touch Lock Type plastic button cover case (DH-**-CT2B)	Lock spring	Stainless steel	—	—
	Button	Polycarbonate resin	Black	UL94V-0
	Tapping screw	Steel	Black chromate(Cr+3)	—
	Cover	Polycarbonate resin	Black	UL94V-0
Lock screw (DH-LNA***)	Shield	Stainless steel	Nickel plated	—
	Lock spring	Stainless steel	—	—
	Button	Polycarbonate resin	Black	UL94V-0
Metal clamp(DH-CMB(**))	Tapping screw	Steel	Black chromate(Cr+3)	—
	Screw lock	Steel	Nickel plated	—
	Waher	Steel	Nickel plated	—
	Spring washer	Steel	Nickel plated	—
	Metal clamp	Brass	—	—

Screw lock type

■ Receptacle connector

● Right angle type

[17pos. DH60-17P]

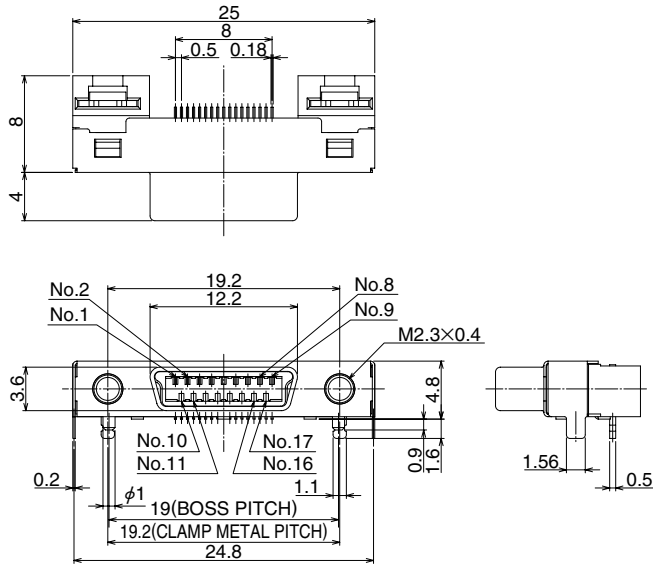
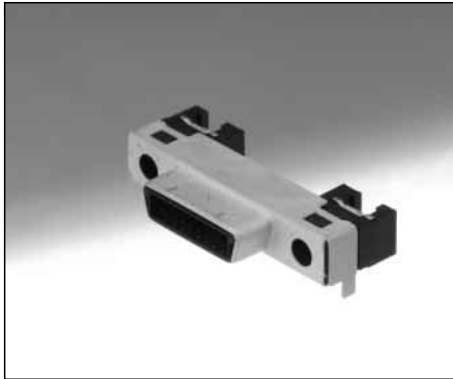

[27pos. DH60-27P]

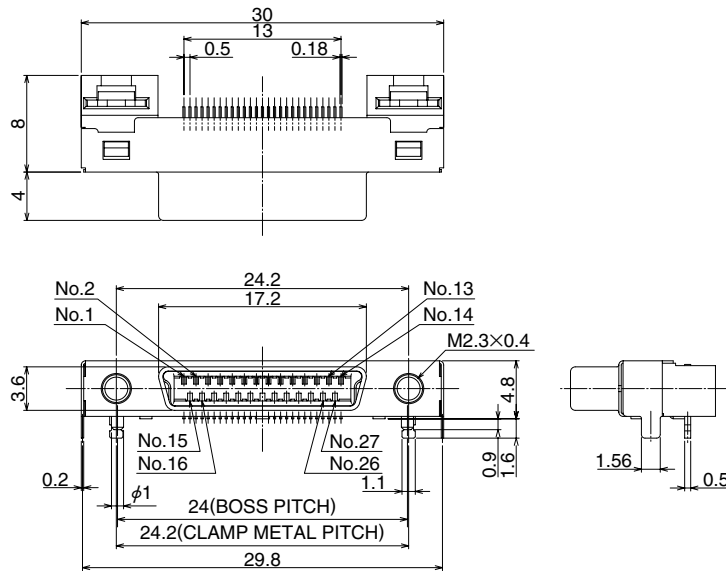
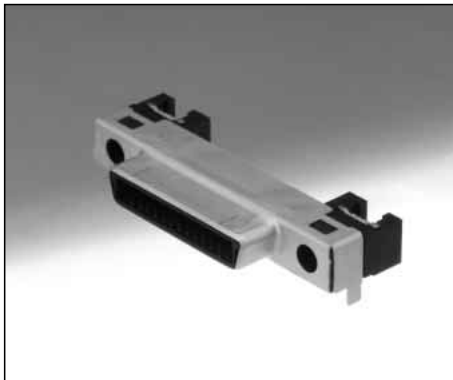

[37pos. DH60-37P]

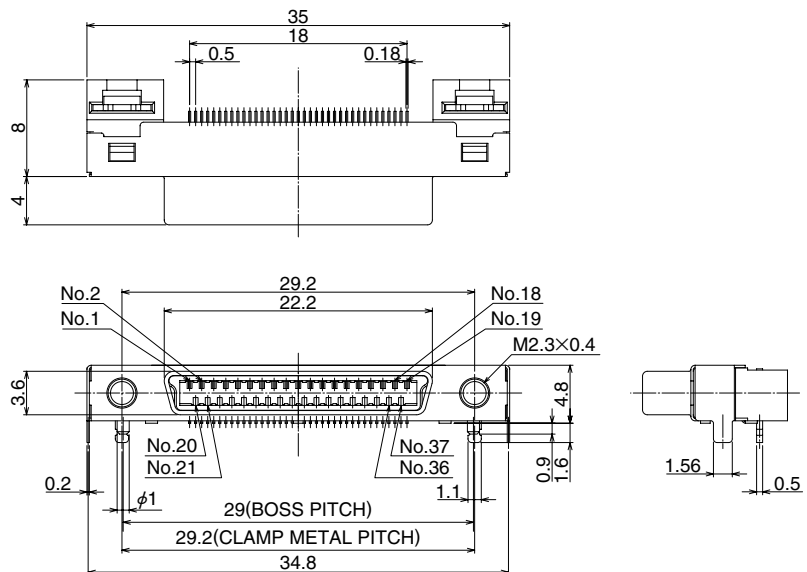

[51pos. DH60-51P]

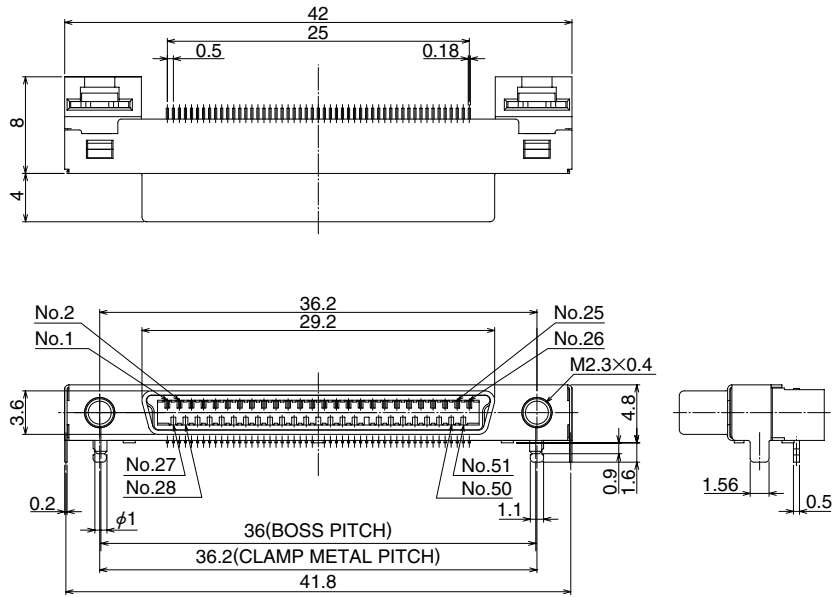
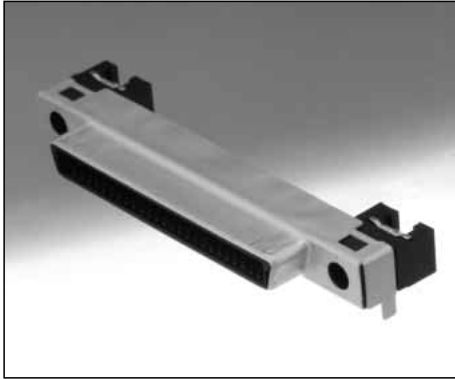

● Straight type

[27pos. DH80-27P]

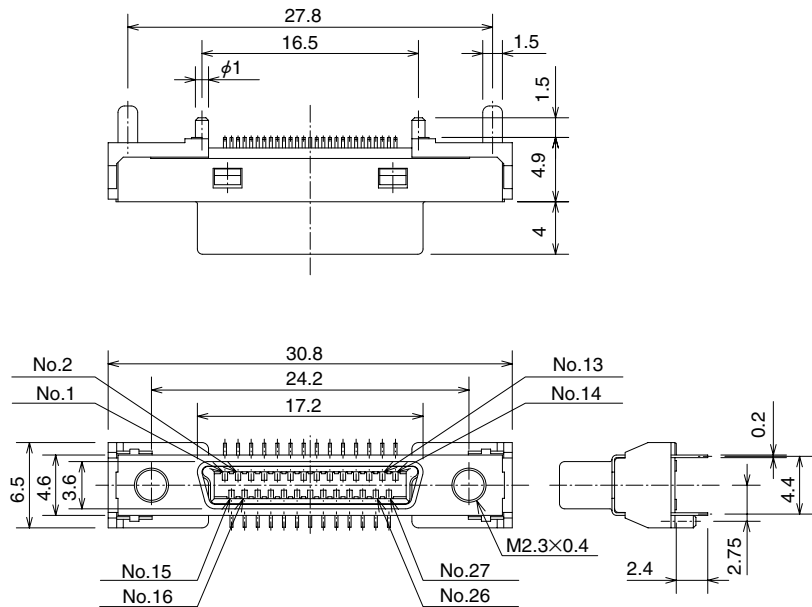
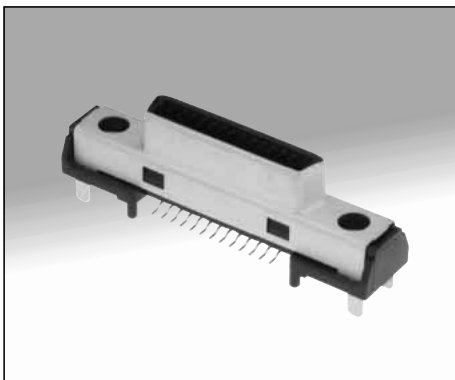

■ Lock screw

[Applicable panel thickness 1.4 to 1.6mm:DH-LNA]

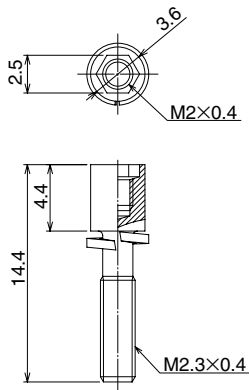

[Applicable panel thickness 0.9 to 1.2mm:DH-LNA-W4]

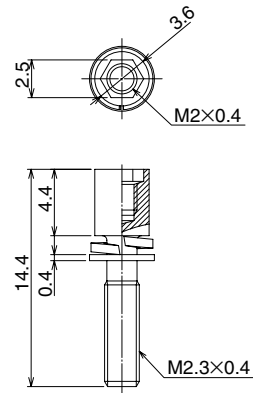

[Applicable panel thickness 0.5 to 0.8mm:DH-LNA-W8]

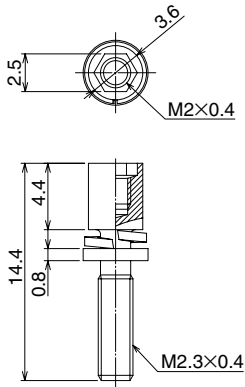

[No panel:DH-LNA-W16]

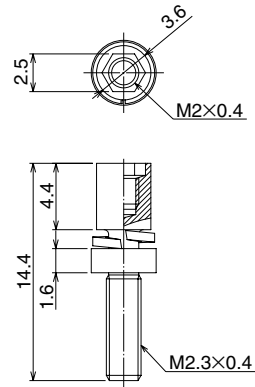

■ Cover case

● Screw lock

[17pos. DH-17-CV1B]



Note 1. This product is delivered separately.
 ② A recommended screw tightening torque to lock screw(DH-LNA***) should be from 0.06 to 0.07N·m.
 ③ A recommended screw tightening torque for covers to be from 0.1 to 0.15N·m.

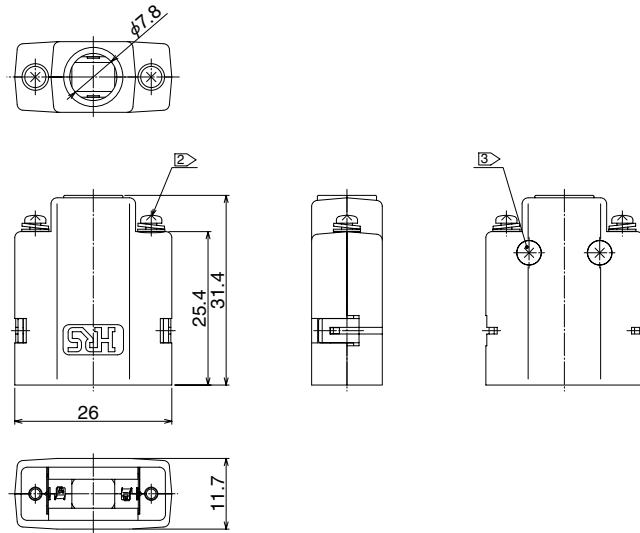

[27pos. DH-27-CV1B]

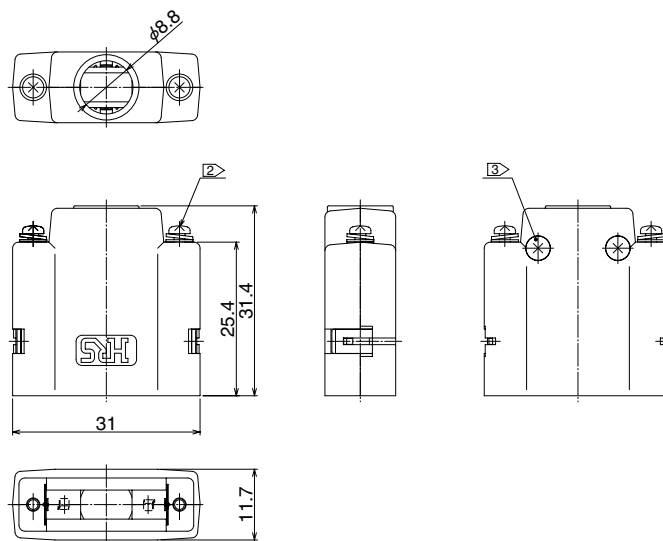

[37pos. DH-37-CV1B]

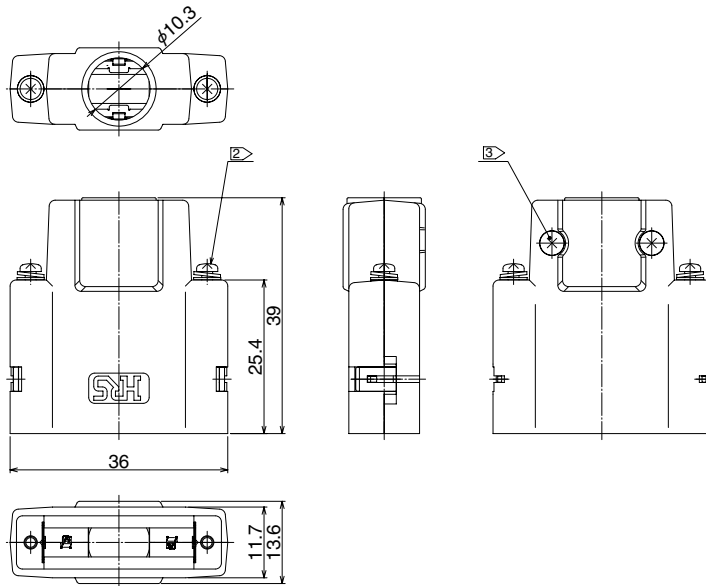

[51pos. DH-51-CV2B]

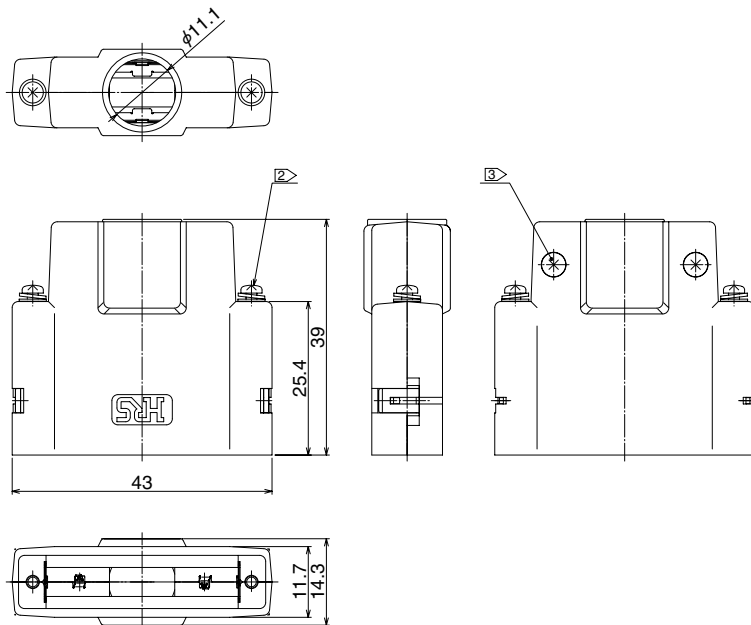

● Hand screw
[17pos. DH-17-CV2B]



Note 1. This product is delivered separately.
 ② A recommended screw tightening torque to the lock screws to be from 0.06 to 0.07N·m.
 ③ A recommended screw tightening torque for covers to be from 0.1 to 0.15N·m.

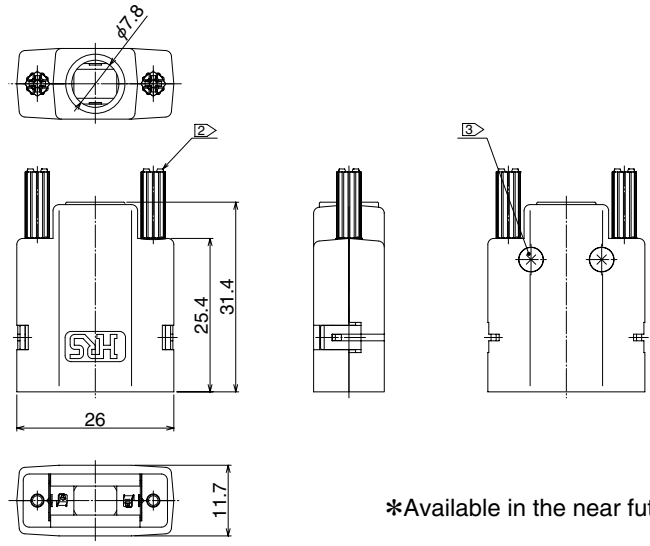

*Available in the near future

[27pos. DH-27-CV2B]

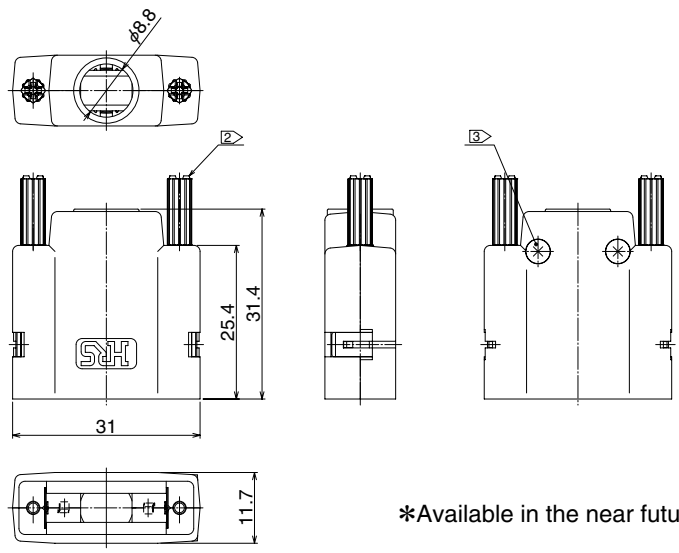

*Available in the near future

[37pos. DH-37-CV2B]

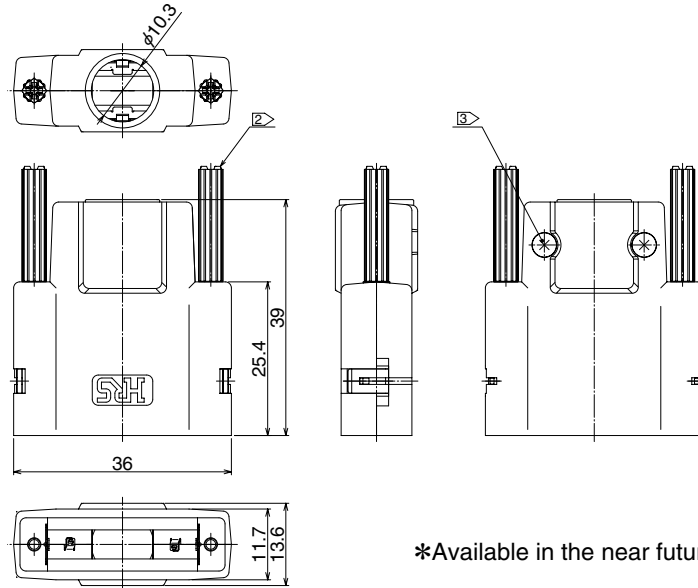
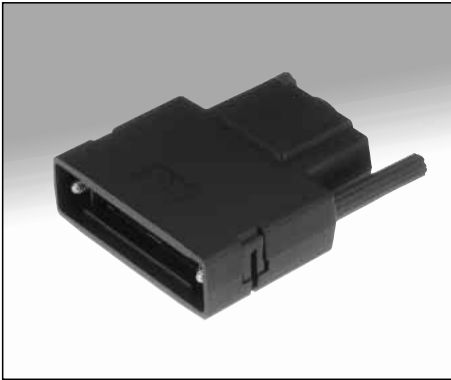

*Available in the near future

[51pos. DH-51-CV2B]

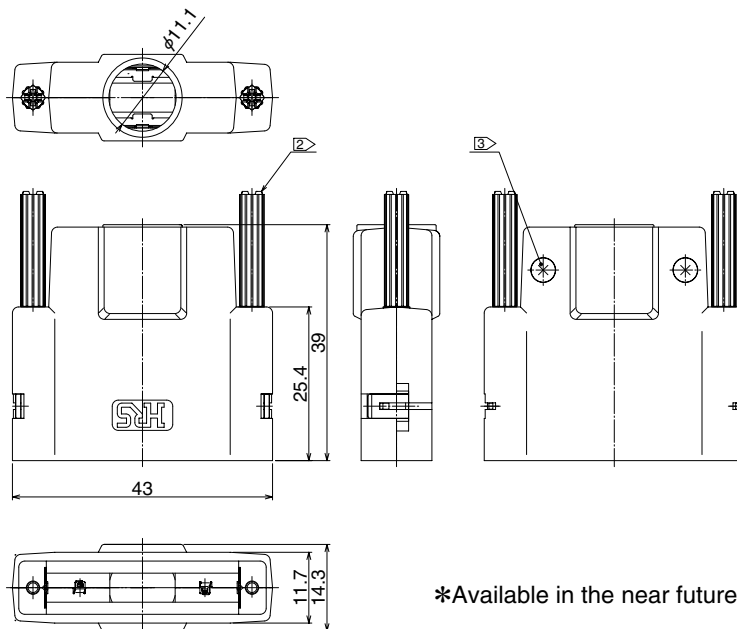

*Available in the near future

One Touch Lock Type

■ Receptacle connector

● Right angle type

[17pos. DH60A-17P]

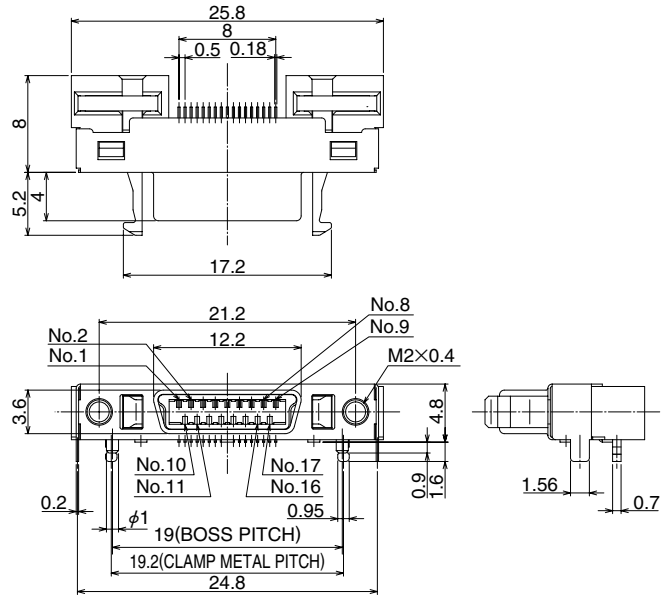
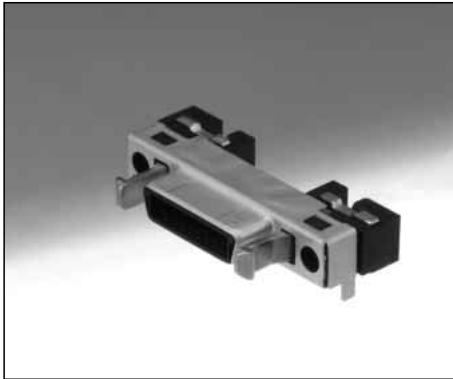

[27pos. DH60A-27P]

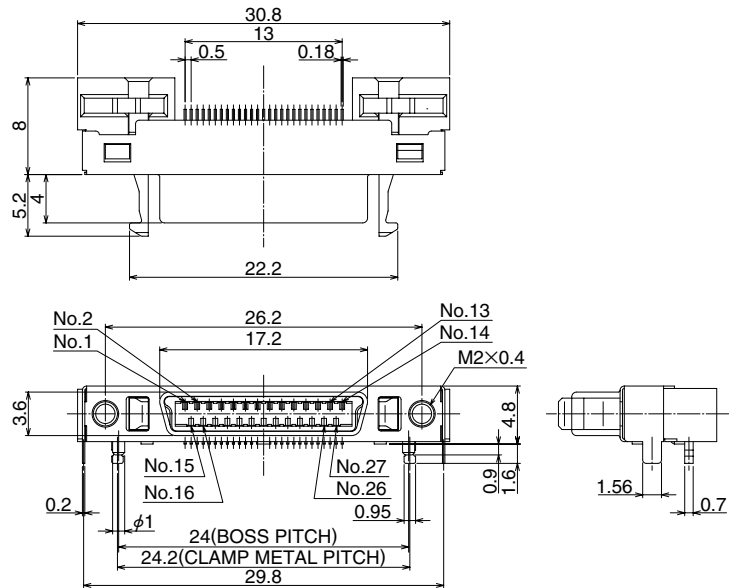

[37pos. DH60A-37P]

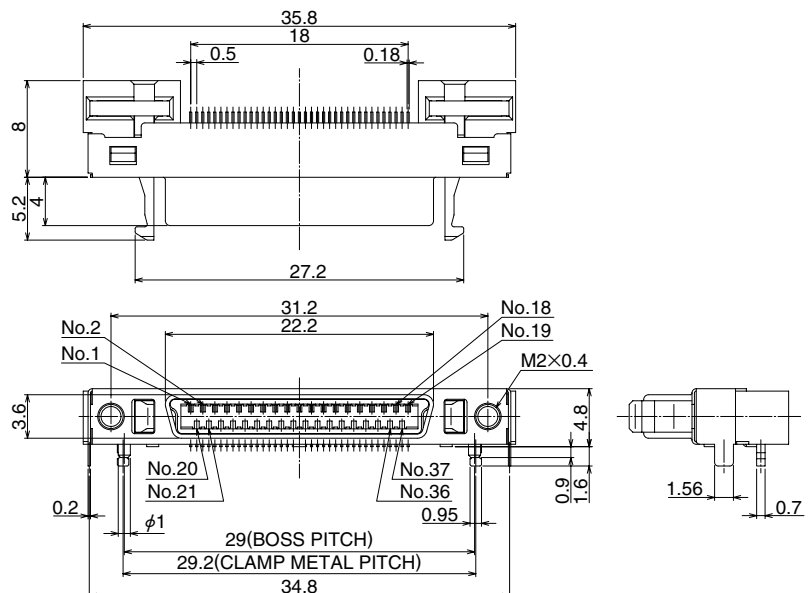

[51pos. DH60A-51P]

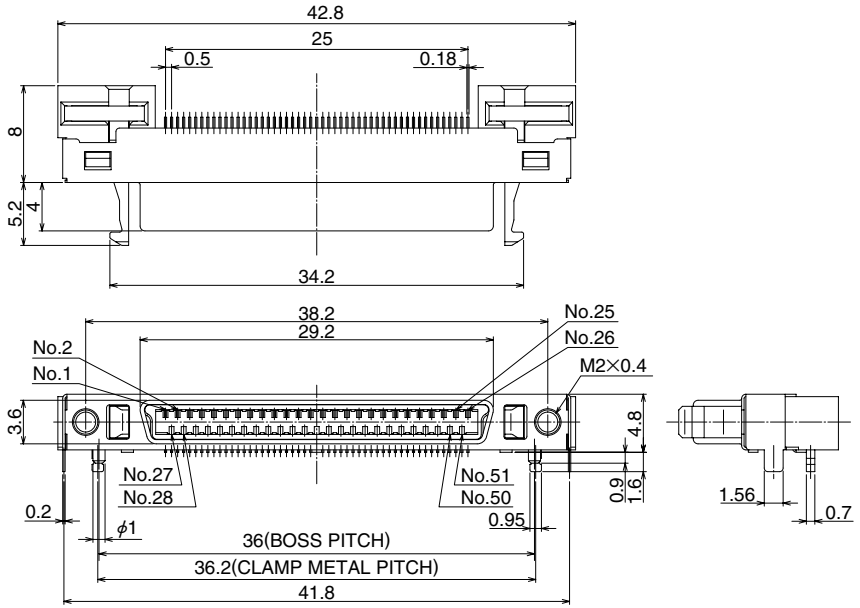
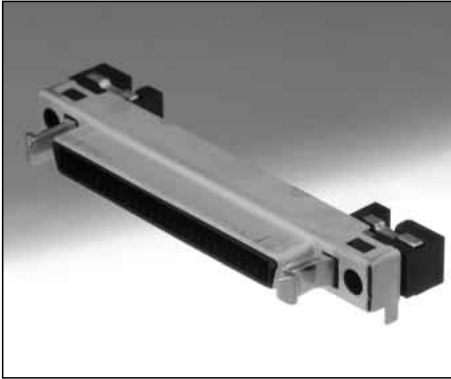

● Straight type

[27pos. DH80A-27P]

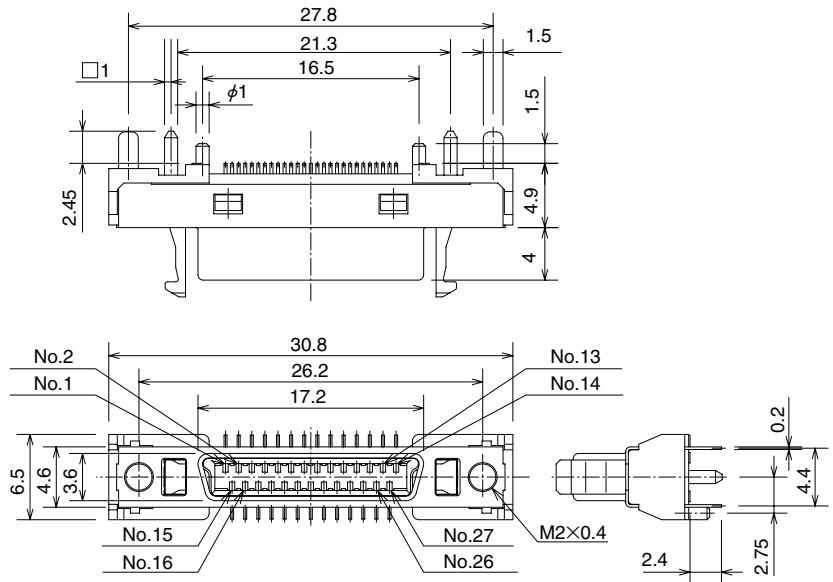

■ Cover case

● Metal button type

[17pos. DH-17-CT1B]

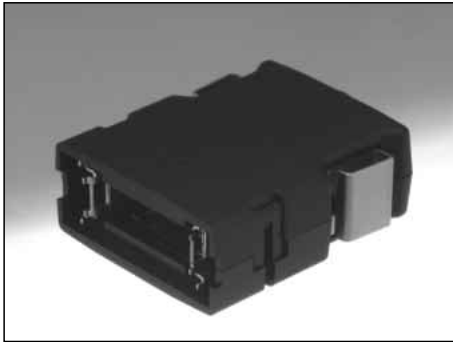

Note 1. This product is delivered separately.

② A recommended screw tightening torque for covers to be from 0.1 to 0.15N·m.

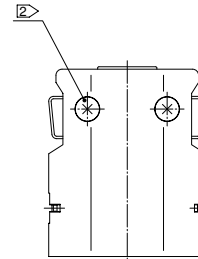
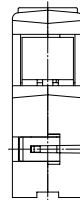
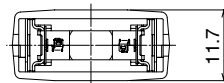
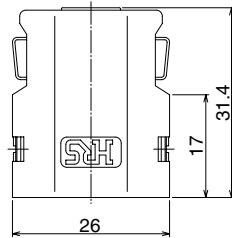
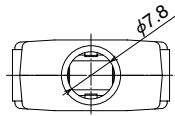

[27pos. DH-27-CT1B]

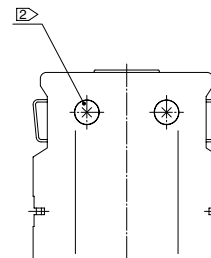
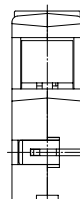
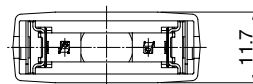
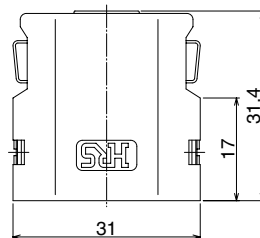
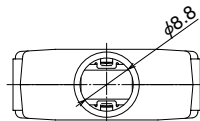

[37pos. DH-37-CT1B]

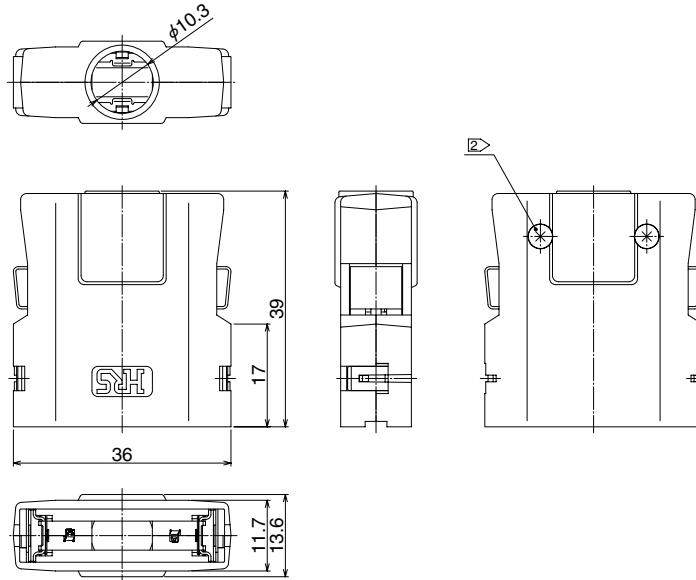
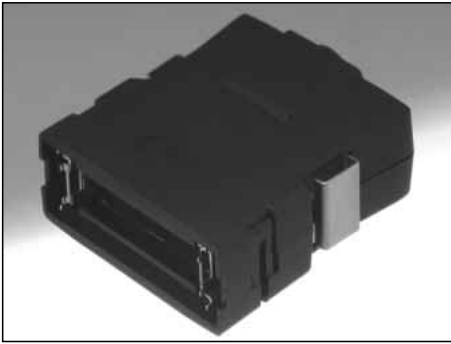

[51pos. DH-51-CT1B]

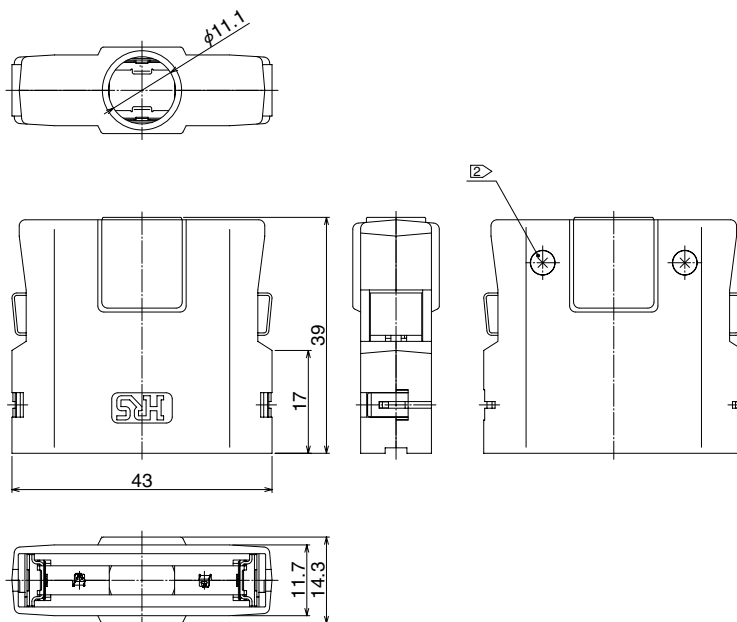

● Plastic button type
[17pos. DH-17-CT2B]

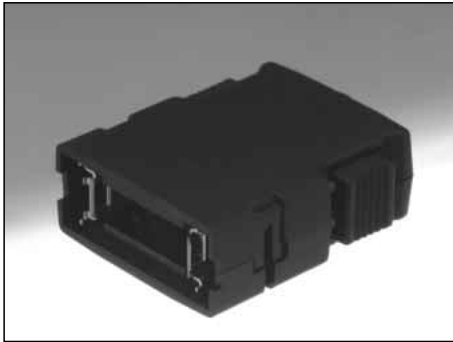

Note 1. This product is delivered separately.
② A recommended screw tightening torque for covers to be from 0.1 to 0.15N·m.

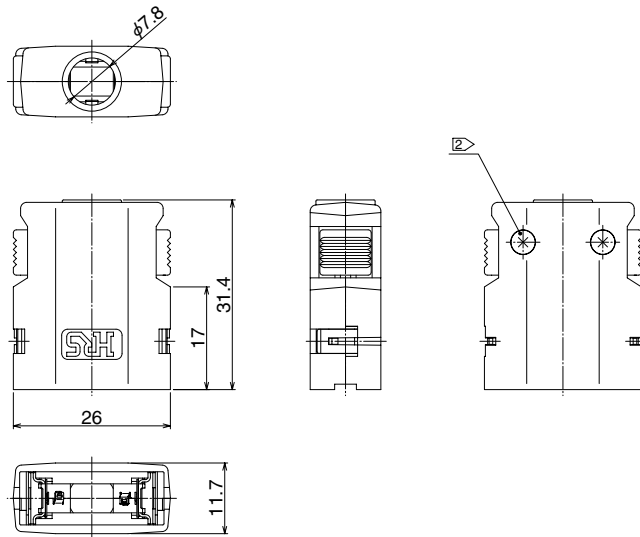

[27pos. DH-27-CT2B]

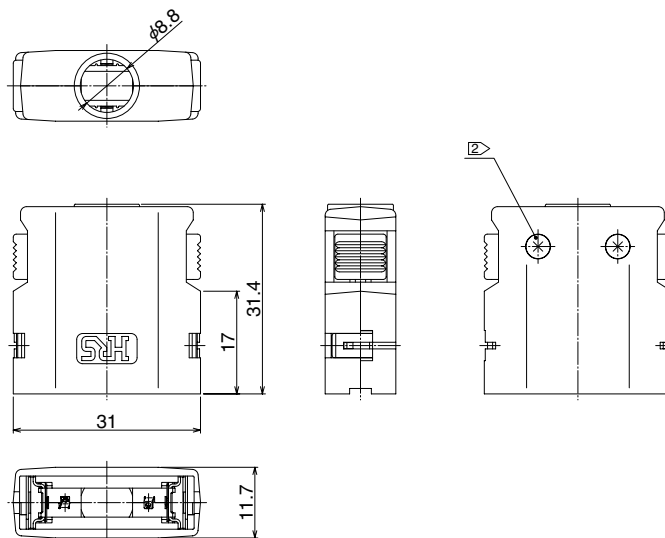
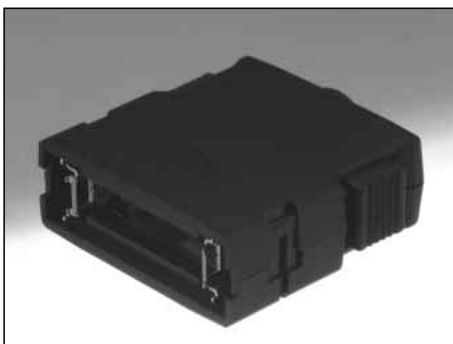

[37pos. DH-37-CT2B]

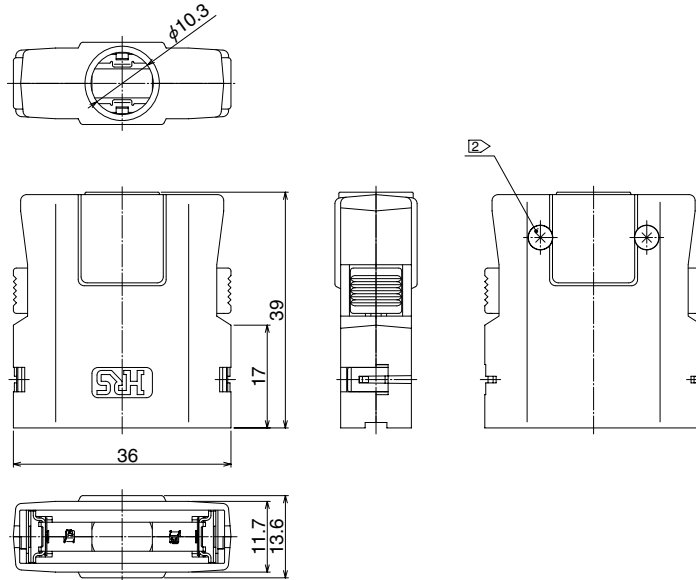

[51pos. DH-51-CT2B]

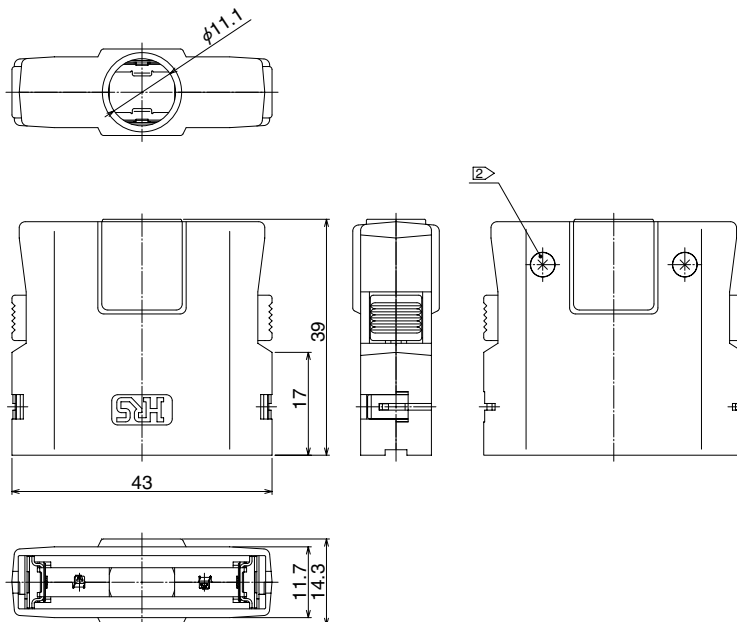

■ Plug unit

● IDC type

[17pos. DH30B-17S]

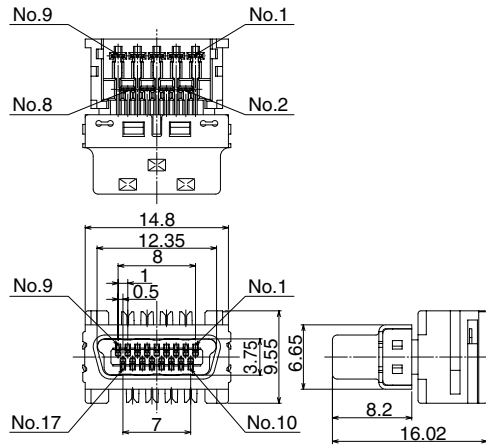

Bundled parts

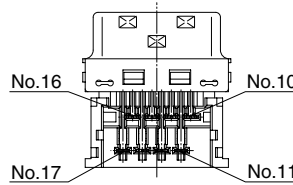
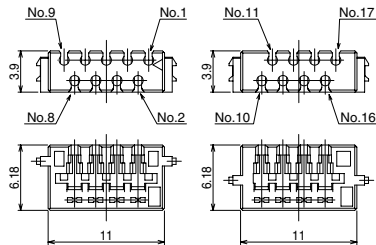

[27pos. DH30B-27S, DH30B-27S]

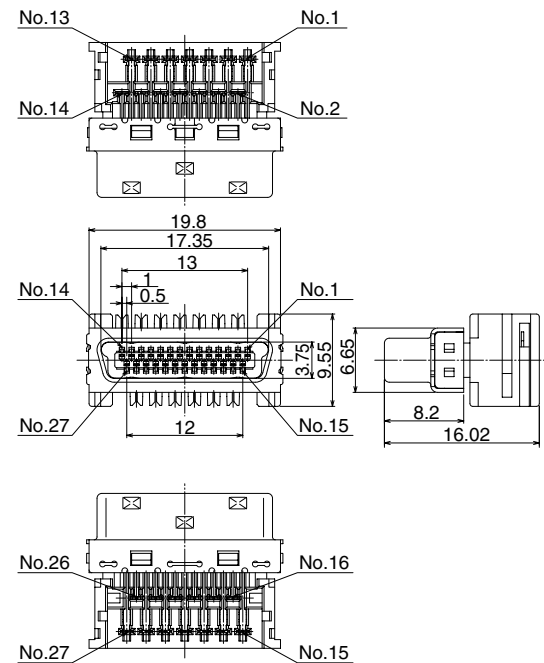

Bundled parts

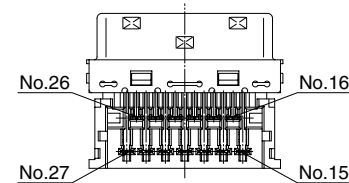
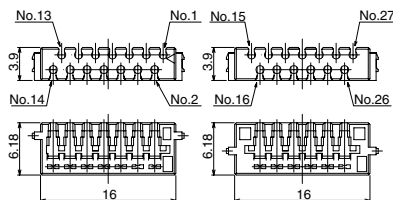

*DH30B-27S and DH32B-27S are different holes in the attached parts.

[37pos. DH30B-37S]

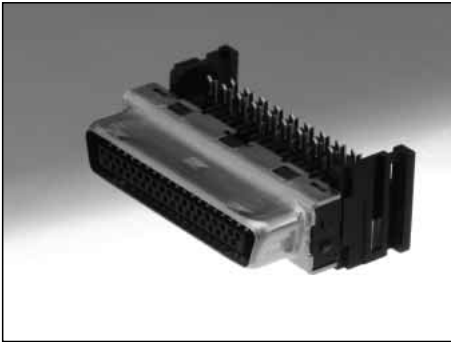

Bundled parts

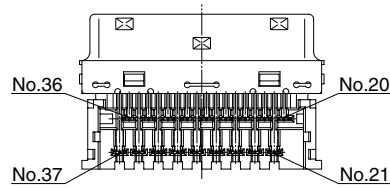
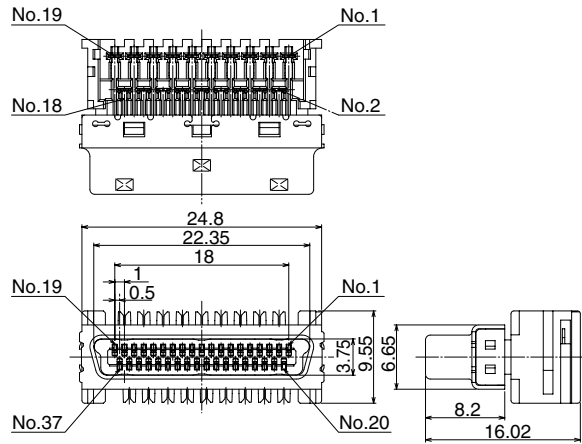
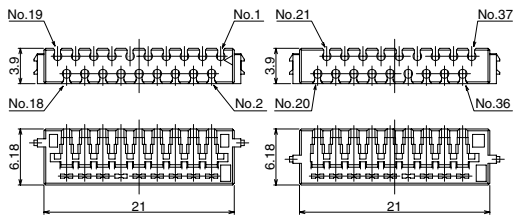

[51pos. DH30B-51S]



Bundled parts

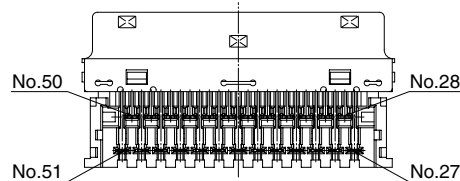
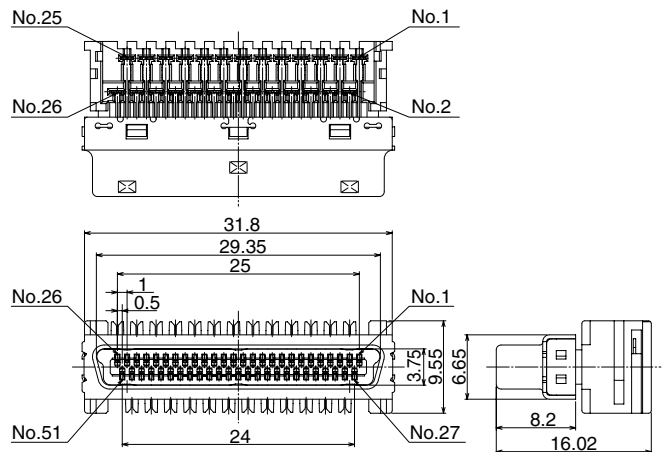
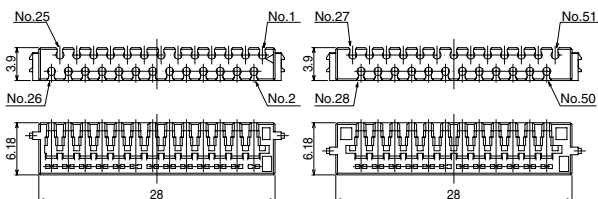

● Solder contact type

[27pos. DH40-27S]

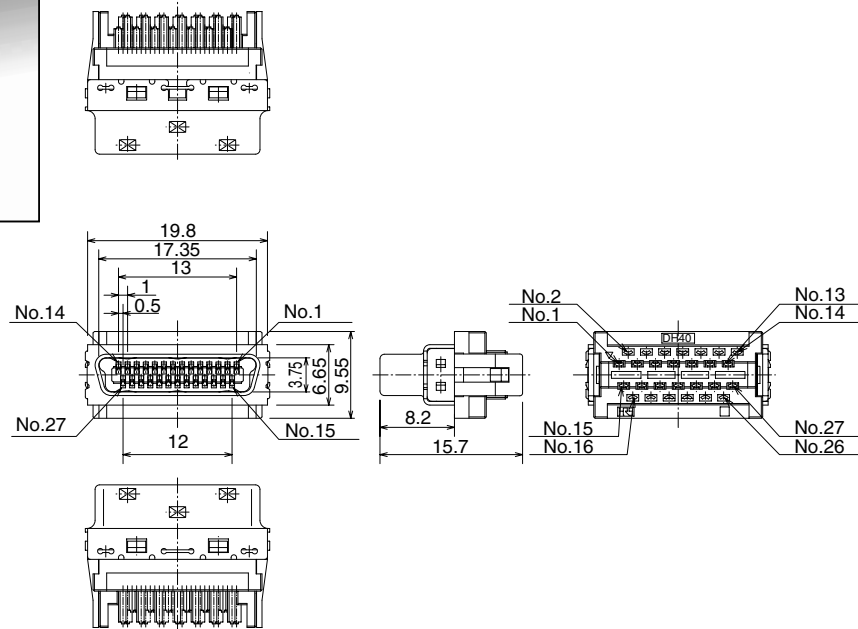
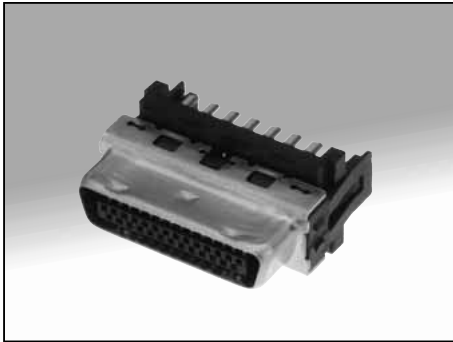

[37pos. DH40-37S]

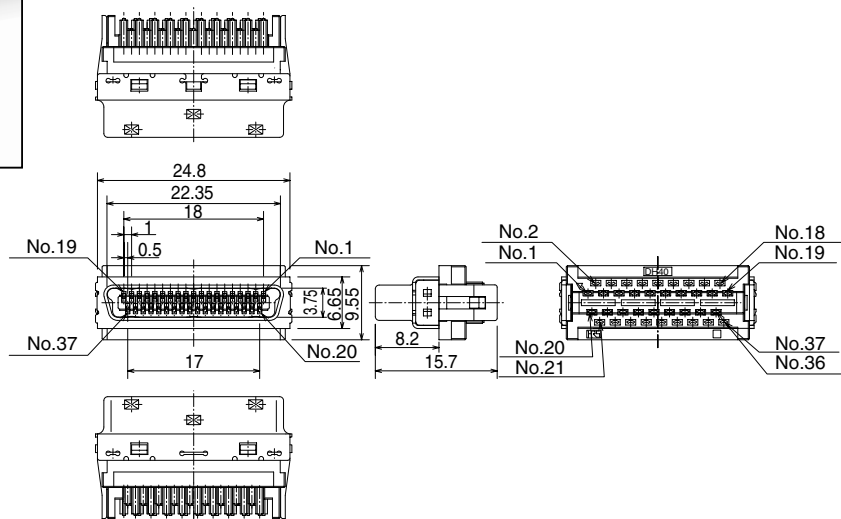

■Metal clamp

[17pos. DH-17-CMB(6.3)]
(Cable outer diameter 6.3mm)

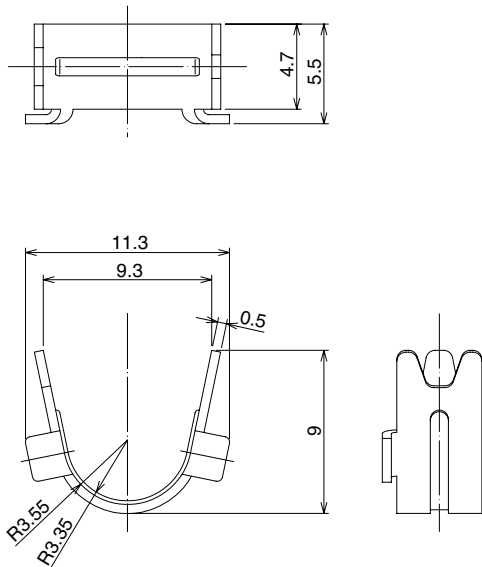

[27pos. DH-27-CMB(6.9)]
(Cable outer diameter 6.9mm)

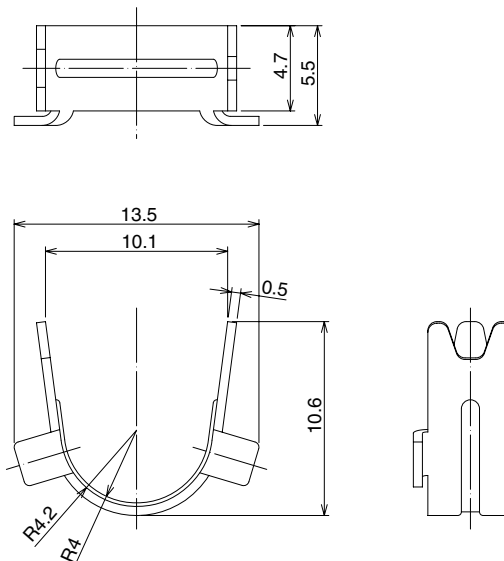

[27pos. DH-27-CMB(7.3)]
(Cable outer diameter 7.3mm)

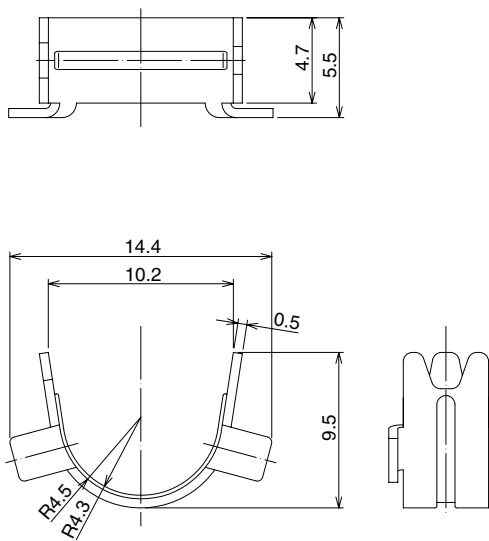

[37pos. DH-37-CMB(8.8)]
(Cable outer diameter 8.8mm)

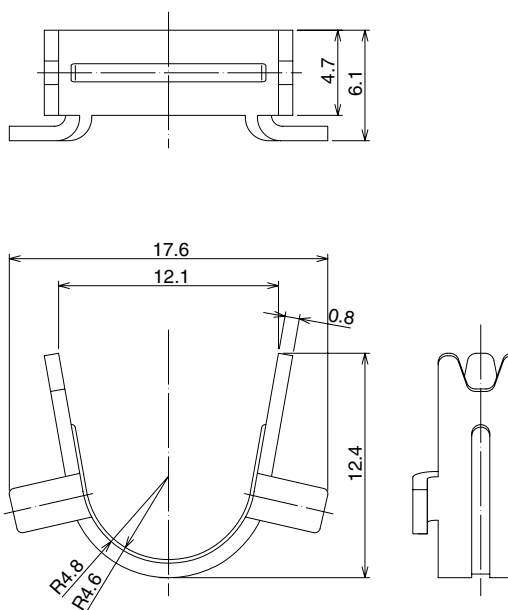

[51pos. DH-51-CMB(9.6)]
(Cable outer diameter 9.6mm)

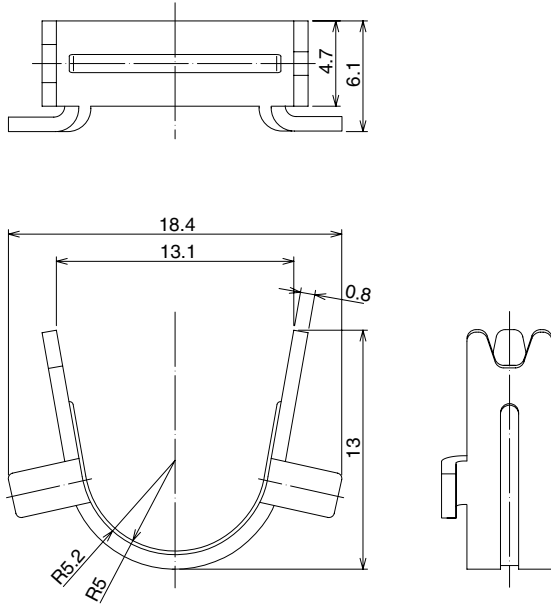

Recommended PCB Mounting pattern

●DH60-***P, DH60A-***P

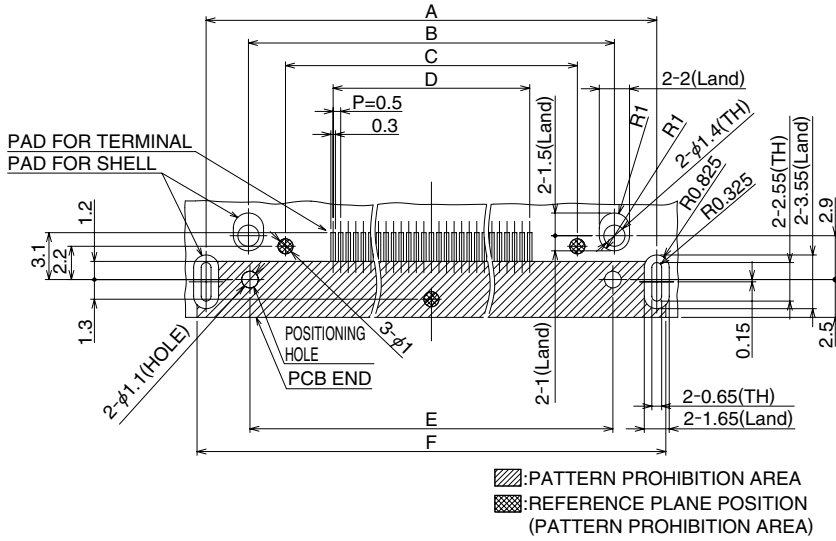

Unit:mm

	A	B	C	D	E	F
DH60-17P DH60A-17P	24.8	19.2	14.3	8	19	26
DH60-27P DH60A-27P	29.8	24.2	19.3	13	24	31
DH60-37P DH60A-37P	34.8	29.2	24.3	18	29	36
DH60-51P DH60A-51P	41.8	36.2	31.3	25	36	43

●DH80-27P

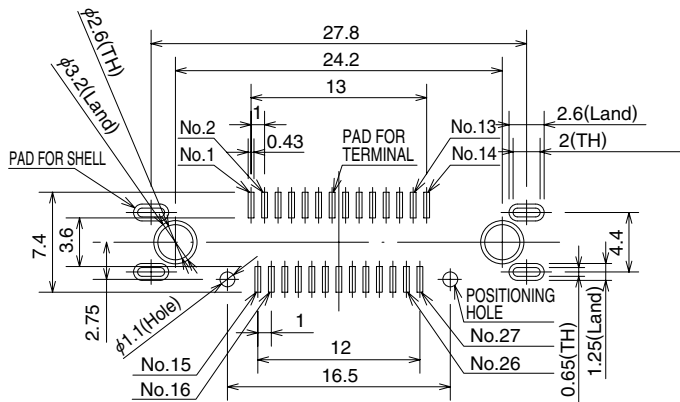

●DH80A-27P

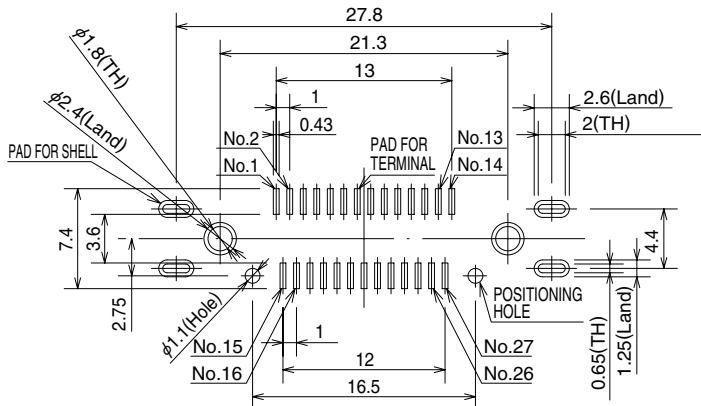

Terminal No.chart

●DH60-***P, DH60A-***P

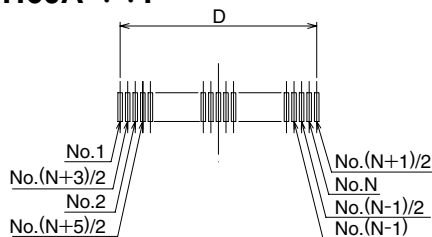

*N: Number of positions

Panel cutout

Screw lock type

Panel cutout for reference (Right angle type, Straight type)

(The dimension is specified based on the center of the connector interface)

DH-LNA(CL244-0045-0-00)

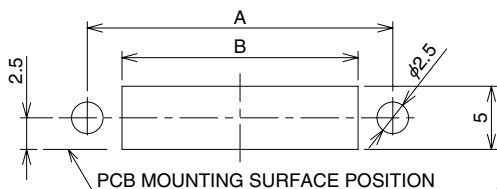

*Please set piercing R as less than R1.

DH-LNA-W4(CL244-0046-2-00)

DH-LNA-W8(CL244-0004-2-00)

DH-LNA-W16(CL244-0005-5-00)

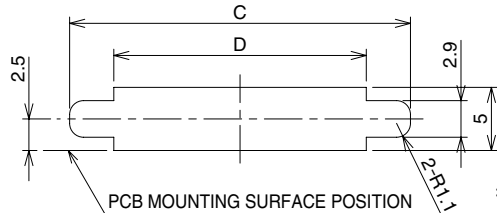

*Please set piercing R as less than R1.

A·B·C·D dimension table

Unit:mm

Number of contacts	A	B	C	D
17	19.2	13.7	22	15
27	24.2	18.7	27	20
37	29.2	23.7	32	25
51	36.2	30.7	39	32

Connector mounted on PCB

(For example, panel thickness is 1.6mm)

*The drawing is shown sample of DH60-27P.

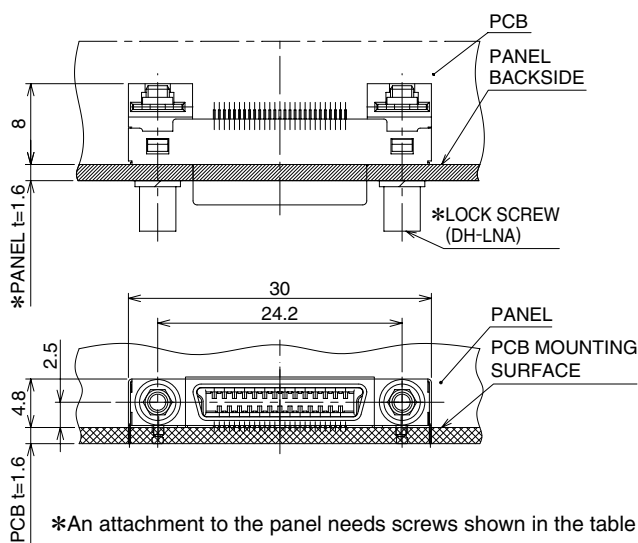

*An attachment to the panel needs screws shown in the table below.

Applicable panel thickness(mm)	Part No.	Code No.
1.4 to 1.6	DH-LNA	244-0045-0-00
0.9 to 1.2	DH-LNA-W4	244-0046-2-00
0.5 to 0.8	DH-LNA-W8	244-0004-2-00
No panel	DH-LNA-W16	244-0005-5-00

*The recommended screw tightening torque to be from 0.12 to 0.3 N·m

*DH80-27P

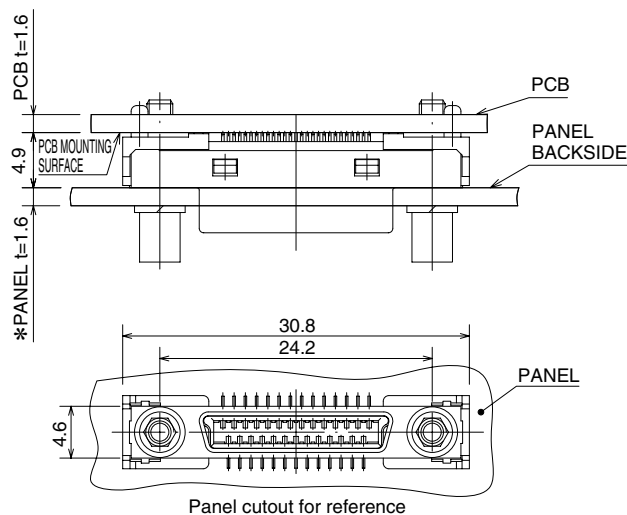

Panel cutout for reference

●One Touch Lock Type

Panel cutout for reference (Right angle type, Straight type)

(The dimension is specified based on the center of the connector interface)

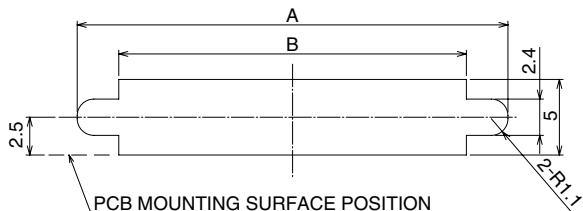

*Please set piercing R as less than R1.

A·B dimension table

Unit:mm

Number of contacts	A	B
17	23.5	18
27	28.5	23
37	33.5	28
51	40.5	35

Connector mounted on PCB

*DH60A-27P is representative examples.

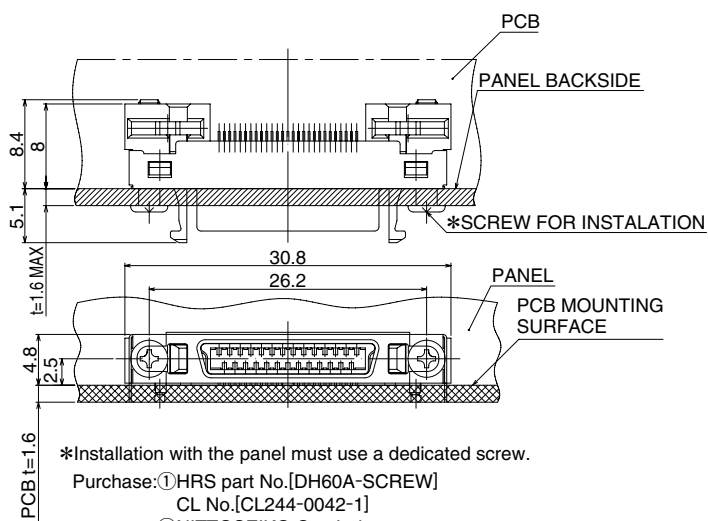

*Installation with the panel must use a dedicated screw.

Purchase: ①HRS part No.[DH60A-SCREW]
 CL No.[CL244-0042-1]
 ②NITTOSEIKO Co., Ltd.
 [FINE PAN HEAD MACHINE SCREW 2 TYPES]

*SCREW FOR INSTALATION

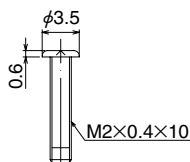

*DH80A-27P

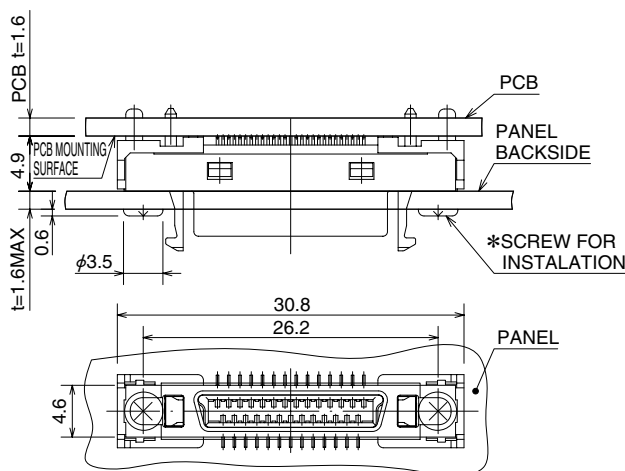

*Installation with the panel must use a dedicated screw.

Purchase: ①HRS part No.[DH80A-SCREW]
 CL No.[CL244-0059-4]
 ②NITTOSEIKO Co., Ltd.
 [FINE PAN HEAD MACHINE SCREW 2 TYPES]

*SCREW FOR INSTALATION

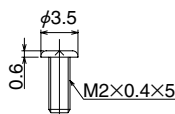

■ Applicable tools

	Process	Part No.	CL No.
1	Cable end processing	manual work	
2	Upper level wire arranging	wire arranging tool : DH/CA-MO	CL902-2183-0
3	Upper level press fitting		
4	Lower level wire arranging		
5	Lower level press fitting		
6	Cable cutting	manual work(nipper etc.)	
7	IDC	① IDC-clamping tool:DH/IDCK-MP	CL902-2185-5
		② attachment for 17pos:DH-17UNIT	CL902-2186-8
		attachment for 27pos:DH-27UNIT	CL902-2187-0
		attachment for 37pos:DH-37UNIT	CL902-2188-3
		attachment for 51pos:DH-51UNIT	CL902-2189-6
		③ HI-FLEX termination press (Select appropriate attachment of each pin count from ②.)	CL550-0082-2
8	Cable clamping	① IDC-clamping tool:DH/IDCK-MP	CL902-2185-5
		② attachment for DH-17-CMB(6.3):DH-17-CMB(6.3)UNIT	CL902-2190-5
		attachment for DH-27-CMB(6.9):DH-27-CMB(6.9)UNIT	CL902-2194-6
		attachment for DH-27-CMB(7.3):DH-27-CMB(7.3)UNIT	CL902-2191-8
		attachment for DH-37-CMB(8.8):DH-37-CMB(8.8)UNIT	CL902-2192-0
		attachment for DH-51-CMB(9.6):DH-51-CMB(9.6)UNIT	CL902-2193-3
		③ HI-FLEX termination press (Select appropriate attachment of each pin count from ②.)	CL550-0082-2
9	Cover attaching	manual work(torque driver etc.)	

*Customers already having HI-FLEX termination press can apply it to this product assembly.

*Each ① and ③ of 7. IDC and 8. Clamping are the same tools. All the parts ①, ② and ③ are required for each 7. IDC and 8. Clamping processes for mass-production.

USA:

HIROSE ELECTRIC (U.S.A.), INC. Headquarters

2688 Westhills Court, Simi Valley, CA 93065-6235
Phone : 1-805-522-7958
Fax : 1-805-522-3217
<http://www.hiroseusa.com>

USA:

HIROSE ELECTRIC (U.S.A.), INC. North California Office

20400 Stevens Creek Blvd., Ste 250, Cupertino, CA 95014
Phone : 1-408-253-9640
Fax : 1-408-253-9641
<http://www.hiroseusa.com>

USA:

HIROSE ELECTRIC (U.S.A.), INC. Detroit Office (Automotive)

37677 Professional Center Drive, Suite #100C Livonia, MI 48154
Phone : 1-734-542-9963
Fax : 1-734-542-9964
<http://www.hiroseusa.com>

GERMANY:

HIROSE ELECTRIC EUROPE B.V. GERMAN BRANCH

Herzog-Carl-Strasse 4 D-73760 Ostfildern (Scharnhauser Park)
Phone : 49-711-4560-02-1
Fax : 49-711-4560-02-299
<http://www.hirose.de>

THE NETHERLANDS:

HIROSE ELECTRIC EUROPE B.V.

Hogehillweg #8 1101 CC Amsterdam Z-0
Phone : 31-20-6557460
Fax : 31-20-6557469
<http://www.hiroseeurope.com>

UK:

HIROSE ELECTRIC EUROPE B.V. UK BRANCH

First Floor, St Andrews House, Caldecotte Lake Business Park, Milton Keynes MK7 8LE
Phone : 44-1908-369060
Fax : 44-1908-369078
<http://www.hirose.co.uk>

CHINA:

HIROSE ELECTRIC CO., LTD. BEIJING REPRESENTATIVE OFFICE

A1001, Ocean International Center, Building 56# East 4th Ring Middle Road, Chao Yang District, Beijing, 100025
Phone : 86-10-5165-9332
Fax : 86-10-5908-1381
<http://www.hirose-china.com.cn>

CHINA:

HIROSE ELECTRIC (SHANGHAI) CO., LTD.

1501-02, Cross Tower Building, 318 Fuzhou Road, Huang Pu District, Shanghai 200001
Phone : 86-21-6391-3355
Fax : 86-21-6335-0767
<http://www.hirose-china.com.cn>

CHINA:

HIROSE ELECTRIC CO., LTD. SHENZHEN OFFICE

Room 09-13, 19/F, Office Tower Shun Hing Square, Di Wang Commercial Centre 5002, ShenNanDong Road, ShenZhen City, Guangdong Province, 518008
Phone : 86-755-8207-0851
Fax : 86-755-8207-0873
<http://www.hirose-china.com.cn>

HONG KONG:

HIROSE ELECTRIC HONGKONG TRADING CO., LTD.

Unit 1102 A&B, Energy Plaza, 92 Granville Road, Tsim Sha Tsui East, Kowloon
Phone : 852-2803-5338
Fax : 852-2591-6560
<http://www.hirose-hongkong.com.hk>

TAIWAN:

HIROSE ELECTRIC TAIWAN CO., LTD.

103 8F, No.87, Zhengzhou Rd., Taipei
Phone : 886-2-2555-7377
Fax : 886-2-2555-7350
<http://www.hirose-taiwan.com.tw>

SINGAPORE:

HIROSE ELECTRIC CO., LTD.

10 Anson Road #26-16 International Plaza 079903
Phone : 65-6324-6113
Fax : 65-6324-6123
<http://www.hirose-singapore.com.sg>

KOREA:

HIROSE KOREA CO., LTD.

1261-10, Jeoungwhang-Dong, Shihung-City, Kyunggi-Do 429-450
Phone : 82-31-496-7000,7124
Fax : 82-31-496-7100
<http://www.hirose.co.kr>

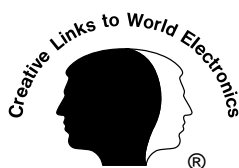

HRS

HIROSE ELECTRIC CO.,LTD.

5-23,OSAKI 5-CHOME,SHINAGAWA-KU,TOKYO 141-8587,JAPAN
PHONE: 81-3-3491-5300, FAX: 81-3-3495-5230
<http://www.hirose.com>
<http://www.hirose-connectors.com>

DH シリーズ ハーネス治具設置メーカー 一覧

2012/04/1 現在
as of Apr. 1, 2012

List of Cable Assembly House for DH Series

地域 Region	対応メーカー / 代理店 Assy House/Distributor	住所 Address	連絡先 Contact	ホームページアドレス HP
日本 Japan	日立電線ファインテック株式会社 Hitachi Cable Fine-Tech,Ltd.	〒319-1411 茨城県日立市川尻町4-10-1 4-10-1,Kawajiricho, Hitachi-Shi, Ibaraki, 319-1411, Japan	TEL:0294-42-5480 FAX:0294-43-6169	http://www.fine.hitachi-cable.co.jp/
	株式会社 マルニックス Marunix Co.,Ltd.	〒343-0011 埼玉県越谷市増林6794-2 6794-2, Masubayashi, Koshigaya-Shi, Saitama, 343-0011, Japan	TEL:048-965-0200 FAX:048-965-2327	http://www.marunix.co.jp
	平河ヒューテック株式会社 HIRAKAWA-HEWTECH CORP.	〒140-8551 東京都品川区南大井3-28-10 JK大森ビル JK OomoriBldg, 3-28-10, Minami-oi, Shinagawa-Ku, Tokyo, 140-8511, Japan	TEL:03-5493-1721 FAX:03-5493-1702	http://www.hewtech.co.jp/index.html
	インターワイヤード株式会社 INTERWAIRERD.CO.,LTD.	〒140-8547 東京都品川区南大井5-19-8 5-19-8,Minami-oi, Shinagawa-Ku, Tokyo, 140-8547, Japan	TEL:03-3761-6787(代) FAX:03-3765-7873	http://www.interwired.co.jp/electricwire/index.html
	日星電気株式会社 NISSEI ELECTRIC CO.,LTD.	〒432-8006 静岡県浜松市西区大久保町 1509番地 1509, Ookubo-Cho, Nishi-Ku, Hamamatsu-Shi, Shizuoka, 432-8006, Japan	TEL:053-485-4705(代) FAX:053-485-5444	http://www.nissei-el.co.jp/
	ダイトデンソー株式会社 DAITO DENSO CO.,LTD.	〒520-3044 滋賀県栗東市伊勢落宇野神 689番地1 1-689, Azanogami, Iseochi, Ritto-Shi, Shiga, 520-3044, Japan	TEL:077-553-7600(代) FAX:077-553-7877	http://www.daitodenso.co.jp/



Компания «ЭлектроПласт» предлагает заключение долгосрочных отношений при поставках импортных электронных компонентов на взаимовыгодных условиях!

Наши преимущества:

- Оперативные поставки широкого спектра электронных компонентов отечественного и импортного производства напрямую от производителей и с крупнейших мировых складов;
- Поставка более 17-ти миллионов наименований электронных компонентов;
- Поставка сложных, дефицитных, либо снятых с производства позиций;
- Оперативные сроки поставки под заказ (от 5 рабочих дней);
- Экспресс доставка в любую точку России;
- Техническая поддержка проекта, помощь в подборе аналогов, поставка прототипов;
- Система менеджмента качества сертифицирована по Международному стандарту ISO 9001;
- Лицензия ФСБ на осуществление работ с использованием сведений, составляющих государственную тайну;
- Поставка специализированных компонентов (Xilinx, Altera, Analog Devices, Intersil, Interpoint, Microsemi, Aeroflex, Peregrine, Syfer, Eurofarad, Texas Instrument, Miteq, Cobham, E2V, MA-COM, Hittite, Mini-Circuits, General Dynamics и др.);

Помимо этого, одним из направлений компании «ЭлектроПласт» является направление «Источники питания». Мы предлагаем Вам помощь Конструкторского отдела:

- Подбор оптимального решения, техническое обоснование при выборе компонента;
- Подбор аналогов;
- Консультации по применению компонента;
- Поставка образцов и прототипов;
- Техническая поддержка проекта;
- Защита от снятия компонента с производства.



Как с нами связаться

Телефон: 8 (812) 309 58 32 (многоканальный)

Факс: 8 (812) 320-02-42

Электронная почта: org@eplast1.ru

Адрес: 198099, г. Санкт-Петербург, ул. Калинина, дом 2, корпус 4, литера А.