

REVISIONS				
P.	LTM	DESCRIPTION	DATE	APVD
F6		REV PER ECR-15-006525	27APR2014	SZ SZ
F7		REV PER ECO-15-007413	18MAY2015	SZ SZ
F8		REV PER ECR-15-018146	15DEC2015	SZ SZ

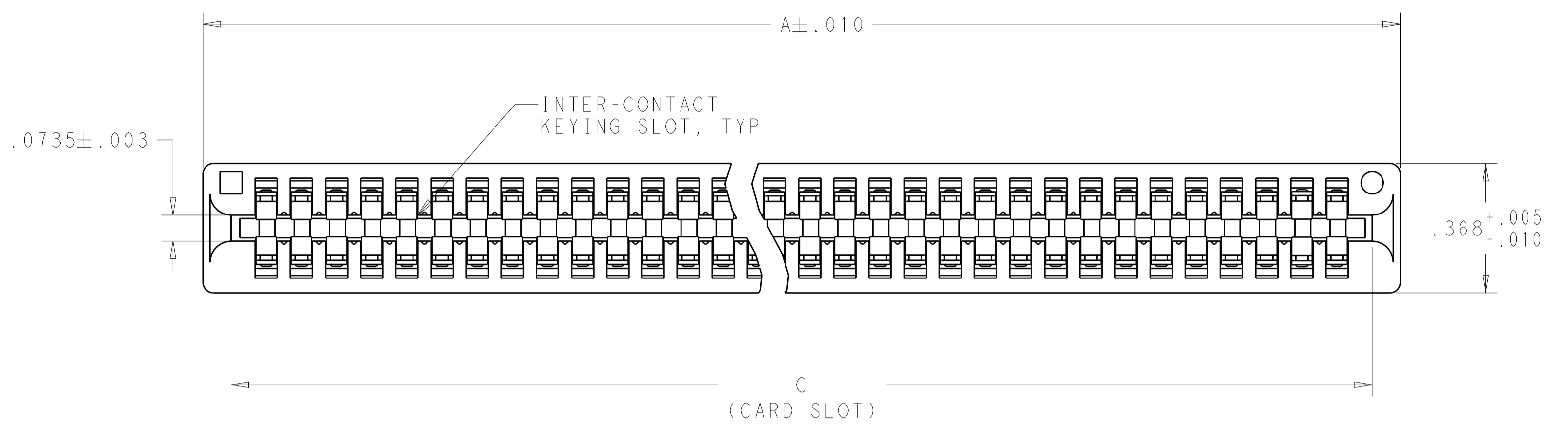

- 1 MATERIAL:
HOUSING - GLASS FILLED POLYESTER, COLOR BLACK
CONTACT - PHOSPHOR BRONZE
- 2 FINISH:
(SEE TABLE FOR GOLD PLATING) IN CONTACT AREA.
.000100 MIN MATTE TIN ON SOLDER POSTS. ALL OVER
.000050 MIN THK. NICKEL
- 3 AMP LOGO, TE PART NUMBER, DATE CODE AND CSA LOGO INK STAMPED WHITE (HOT STAMPED OR LAZER PRINTED) IN THE APPROXIMATE AREA SHOWN, EITHER SIDE PERMISSABLE WHEN HOUSING SIZE PERMITS
- 4. RECOMMENDED PCB FINISHED HOLE $\varnothing .040 \pm .003$
- 5 .000015 MIN
- 6 .000030 MIN
- 7 OBSOLETE PARTS: OBSOLETE CIS STREAMLINING PER D.RENAUD/D.SINISI

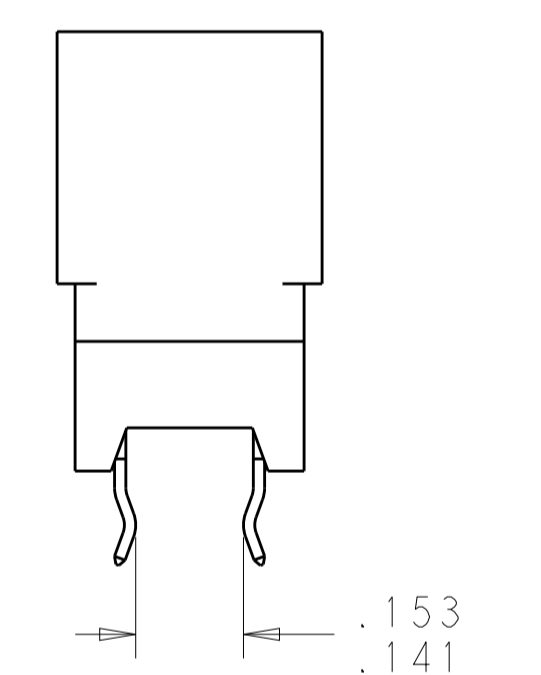
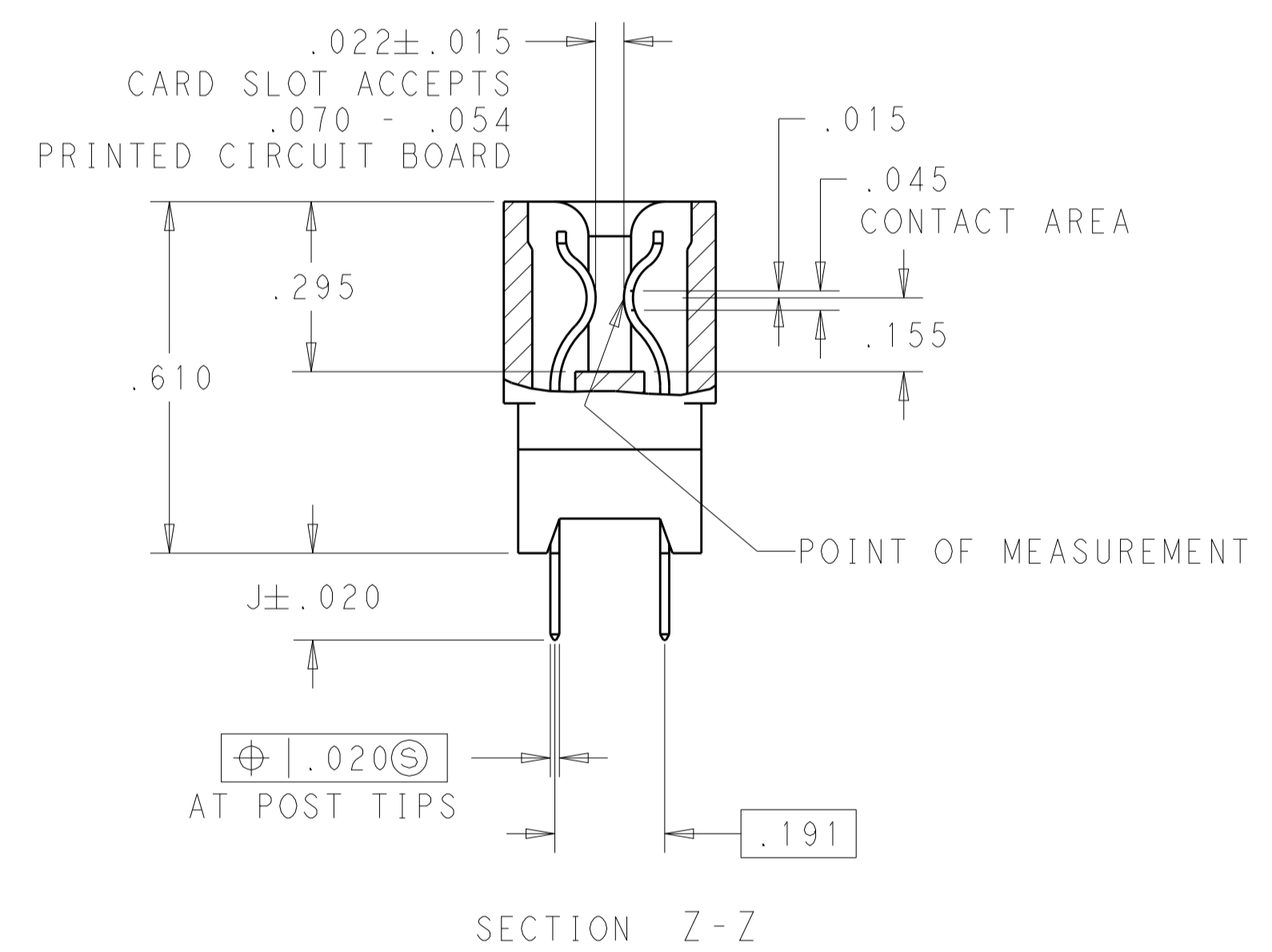
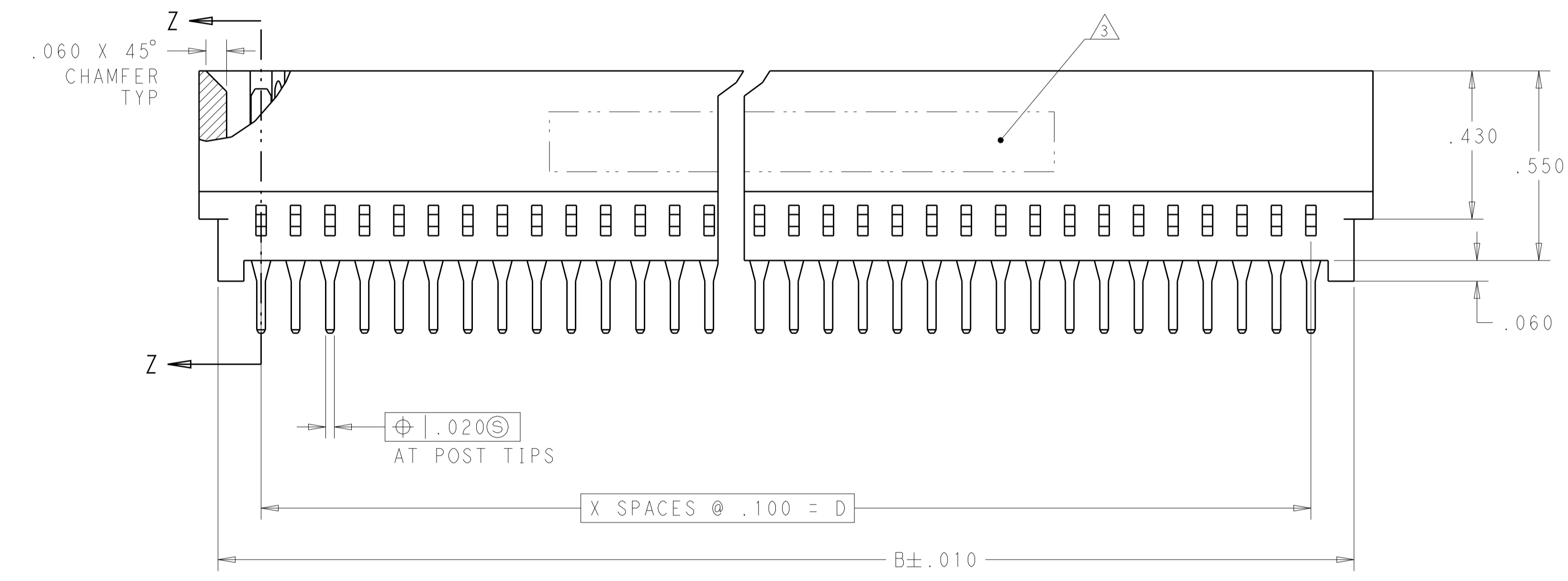

BOARD RETENTION FEATURE
8-530843-3 ONLY

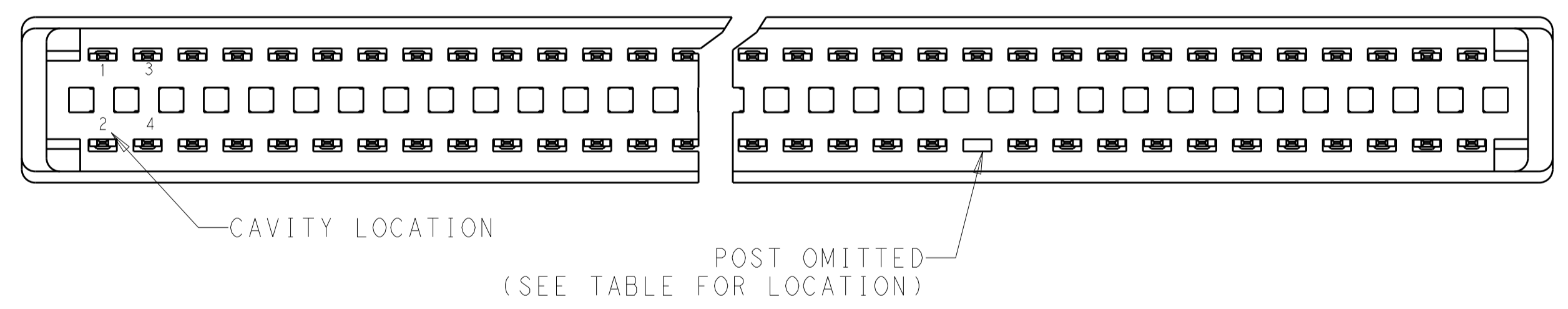

THIS DRAWING IS A CONTROLLED DOCUMENT.		DWN AWF/GRZYBOWSKI	30OCT2009	 TE Connectivity
DIMENSIONS: INCHES		CHK E. HOWARD	APVD M. PERCZYNSKI	
TOLERANCES UNLESS OTHERWISE SPECIFIED:		PRODUCT SPEC		NAME CONNECTOR ASSEMBLY STANDARD EDGE II, .100 CENTERLINE
0 PLC \pm 1 PLC $\pm .005$ 2 PLC \pm 3 PLC \pm 4 PLC \pm ANGLES ± 2		APPLICATION SPEC		
MATERIAL	FINISH	WEIGHT	SIZE A1	CAGE CODE 5530843
CUSTOMER DRAWING		SCALE 4:1	SHEET 1	OF 4
		REV F8		

REVISIONS				
P.	LTN	DESCRIPTION	DATE	APVD
-	-	SEE SHEET 1	-	-

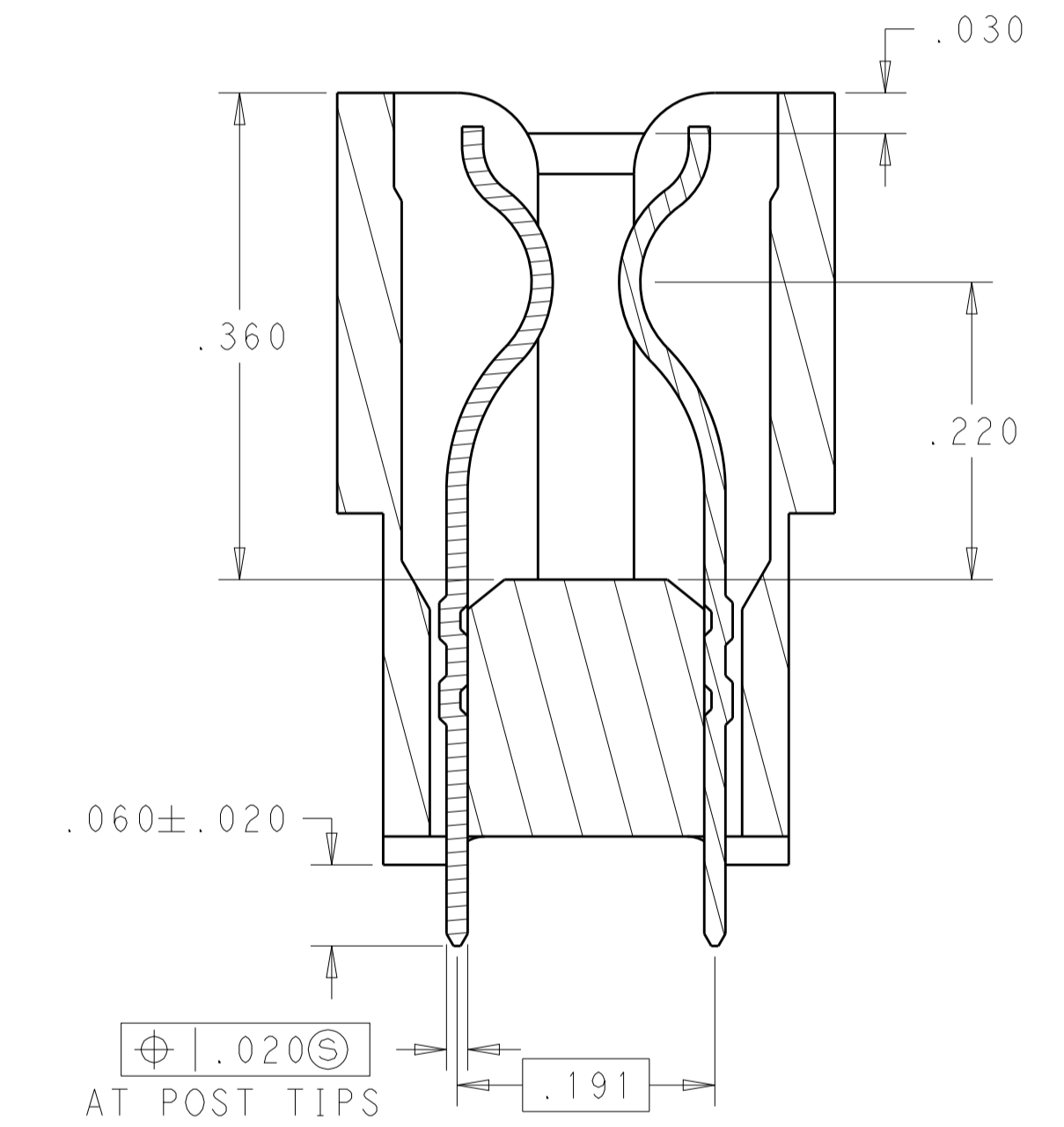
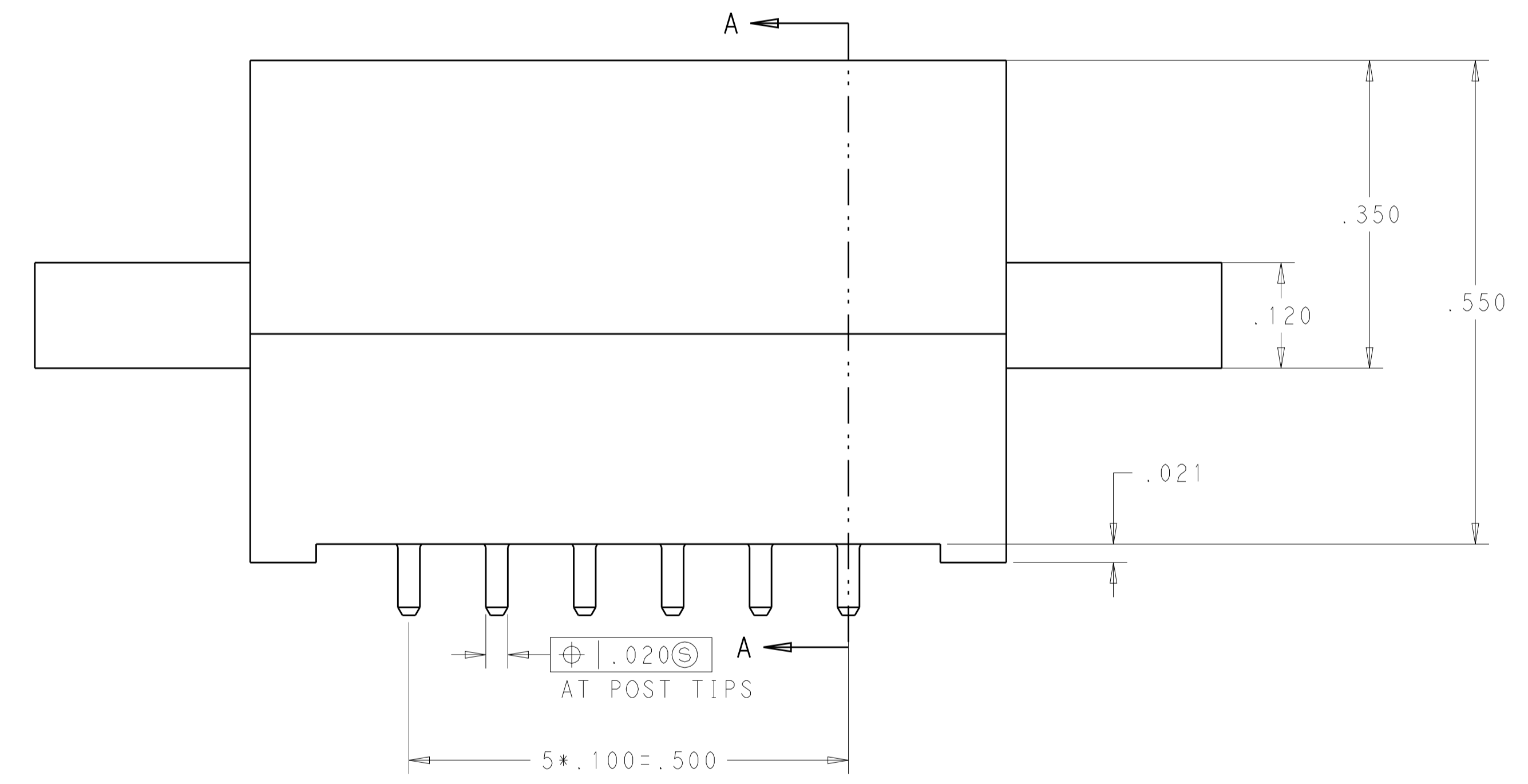
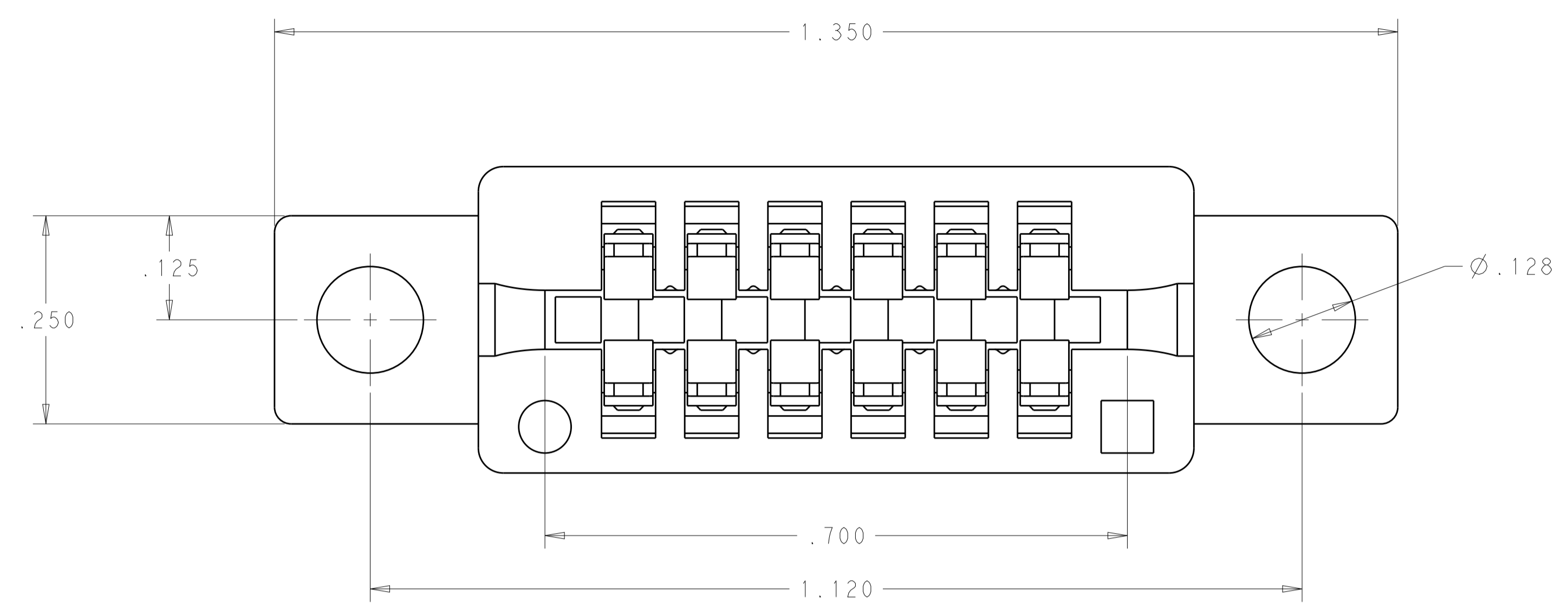

SECTION A-A

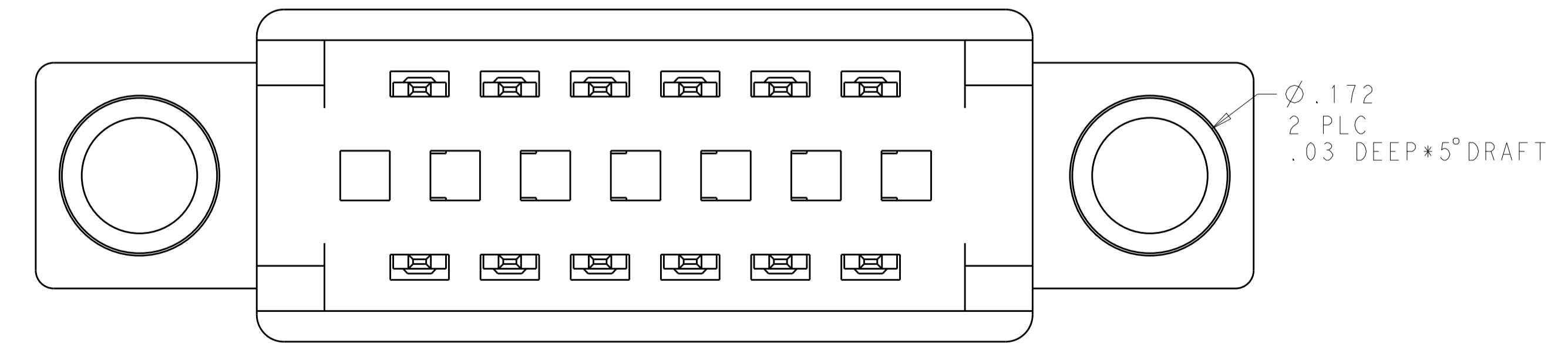

PART 8-5530843-6

THIS DRAWING IS A CONTROLLED DOCUMENT.		DWN: AWF/GRZYBOWSKI 30OCT2009	TE Connectivity
DIMENSIONS: INCHES		CHK: E. HOWARD	
TOLERANCES UNLESS OTHERWISE SPECIFIED:		APVD: M. PERCHERK 30OCT2009	NAME: CONNECTOR ASSEMBLY STANDARD EDGE II, .100 CENTERLINE
0 PLC ±. 1 PLC ±. 2 PLC ±.005 3 PLC ±. 4 PLC ±. ANGLES ±. FINISH #2		PRODUCT SPEC: 108-9039 APPLICATION SPEC: 114-13018 WEIGHT: - CUSTOMER DRAWING	
MATERIAL: -		SIZE: A100779	RESTRICTED TO: -
SCALE: 4:1		CAGE CODE: C=5530843	SHEET 2 OF 4
REV: F8		DATE: -	

REVISIONS				
P.	LTN	DESCRIPTION	DATE	APPD
-	-	SEE SHEET 1	-	-

OBSOLETE	8-5530843-2
OBSOLETE	8-5530843-1
OBSOLETE	4-5530843-1
OBSOLETE	1-5530843-9
OBSOLETE	1-5530843-2
PART NUMBER	

FEATURE	LOCATIONS	FINISH	Z	J	D	C	B	A	X	NO. OF DUAL POSITIONS	PART NUMBER
F8	3, 4, 21, 22, 25, 26, 29, 30, 33, 34	△6	1.886	.125	1.700	1.900	1.950	2.060	17	18	9-5530843-2
	9, 10, 11, 12, 19, 20, 21, 22, 29, 30, 31, 32	△6	2.086	.125	1.900	2.100	2.150	2.260	19	20	9-5530843-1
F6	13, 14, 15, 16, 27, 28, 29, 30	△6	2.086	.125	1.900	2.100	2.150	2.260	19	20	9-5530843-0
F4	3, 4, 5, 6, 9, 10, 13, 14, 17, 18, 19, 20, 21, 22	△6	1.286	.125	1.100	1.300	1.350	1.460	11	12	8-5530843-9
	11, 12, 23, 24, 29, 30, 35, 36, 37, 38	△6	2.086	.125	1.900	2.100	2.150	2.260	19	20	8-5530843-8
	17, 18, 19, 20	△6	1.286	.125	1.100	1.300	1.350	1.460	11	12	8-5530843-7
		△6	0.686	-	.500	.700	-	-	5	6	8-5530843-6
		△6	1.286	.187	1.100	1.300	1.350	1.460	11	12	8-5530843-5
	19, 20, 21, 22, 23, 24, 27, 28, 31, 32, 35, 36, 39 40, 43, 44, 45, 46, 47, 48, 51, 52, 55, 56, 59, 60	△6	3.186	.125	3.000	3.200	3.250	3.360	30	31	8-5530843-4
	3, 4, 5, 6, 19, 20, 21, 22	△6	1.286	.125	1.100	1.300	1.350	1.460	11	12	8-5530843-3
	-	△6	.386	.125	.200	.400	.450	.560	2	3	7-5530843-7
	-	△6	.686	.187	.500	.700	.750	.860	5	6	7-5530843-6
	-	△6	.686	.125	.500	.700	.750	.860	5	6	7-5530843-5
	-	△5	3.186	.125	3.000	3.200	3.250	3.360	30	31	7-5530843-0
	-	△6	3.186	.125	3.000	3.200	3.250	3.360	30	31	6-5530843-5
△7 OBSOLETE	-	△6	6.086	.125	5.900	6.100	6.150	6.260	59	60	5-5530843-5
	-	△6	2.086	.125	1.900	2.100	2.150	2.260	19	20	5-5530843-4
	-	△6	1.786	.125	1.600	1.800	1.850	1.960	16	17	5-5530843-3
	-	△6	1.086	.125	.900	1.100	1.150	1.260	9	10	5-5530843-0
	-	△5	1.886	.125	1.700	1.900	1.950	2.060	17	18	2-5530843-7
	-	△6	3.586	.125	3.400	3.600	3.650	3.760	34	35	2-5530843-3
	-	△6	5.086	.187	4.900	5.100	5.150	5.260	49	50	2-5530843-2
	-	△6	4.086	.187	3.900	4.100	4.150	4.260	39	40	2-5530843-0
	-	△6	3.086	.187	2.900	3.100	3.150	3.260	29	30	1-5530843-8
	-	△6	2.586	.187	2.400	2.600	2.650	2.760	24	25	1-5530843-6
	-	△6	4.386	.125	4.200	4.400	4.450	4.560	42	43	1-5530843-0
	-	△6	3.686	.125	3.500	3.700	3.750	3.860	35	36	5530843-8
	-	△6	3.086	.125	2.900	3.100	3.150	3.260	29	30	5530843-7
	-	△6	2.886	.125	2.700	2.900	2.950	3.060	27	28	5530843-6
	-	△6	2.586	.125	2.400	2.600	2.650	2.760	24	25	5530843-5
	-	△6	2.286	.125	2.100	2.300	2.350	2.460	21	22	5530843-4
	-	△6	1.886	.125	1.700	1.900	1.950	2.060	17	18	5530843-3
	-	△6	1.586	.125	1.400	1.600	1.650	1.760	14	15	5530843-2
	-	△6	1.286	.125	1.100	1.300	1.350	1.460	11	12	5530843-1
OMITTED PIN	BOARD RETENTION FEATURE LOCATION (SEE DETAIL Y)	FINISH	Z	J	D	C	B	A	X	NO. OF DUAL POSITIONS	PART NUMBER

THIS DRAWING IS A CONTROLLED DOCUMENT. DIMENSIONS: INCHES. TOLERANCES UNLESS OTHERWISE SPECIFIED: 0 PLC ±.005, 1 PLC ±.005, 2 PLC ±.005, 3 PLC ±.005, 4 PLC ±.005, ANGLES ±.02. MATERIAL: FINISH: WEIGHT: CUSTOMER DRAWING.

DWN: JAW/GRZYBOWSKI, CHS: E.HOWARD, APVD: M.PERCHEK. PRODUCT SPEC: 108-9039, APPLICATION SPEC: 114-13018. SIZE: A1, CAGE CODE: 00779, DRAWING NO: 5530843, SHEET 3 OF 4, REV: F8.

STE TE Connectivity
 CONNECTOR ASSEMBLY STANDARD EDGE II, .100 CENTERLINE

REVISIONS				
P.	LTN	DESCRIPTION	DATE	APVD
-	-	SEE SHEET 1	-	-

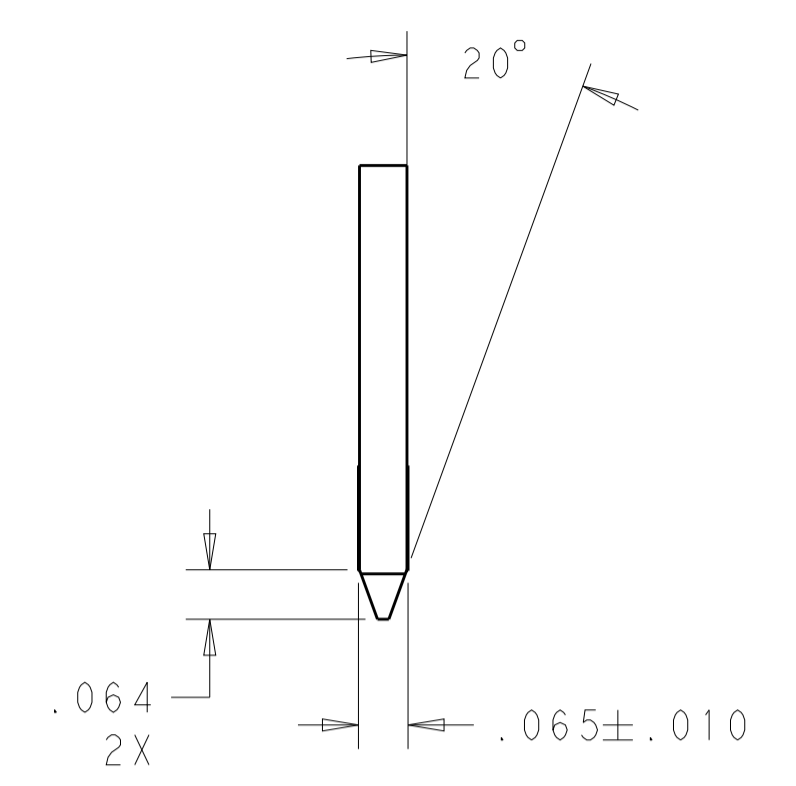
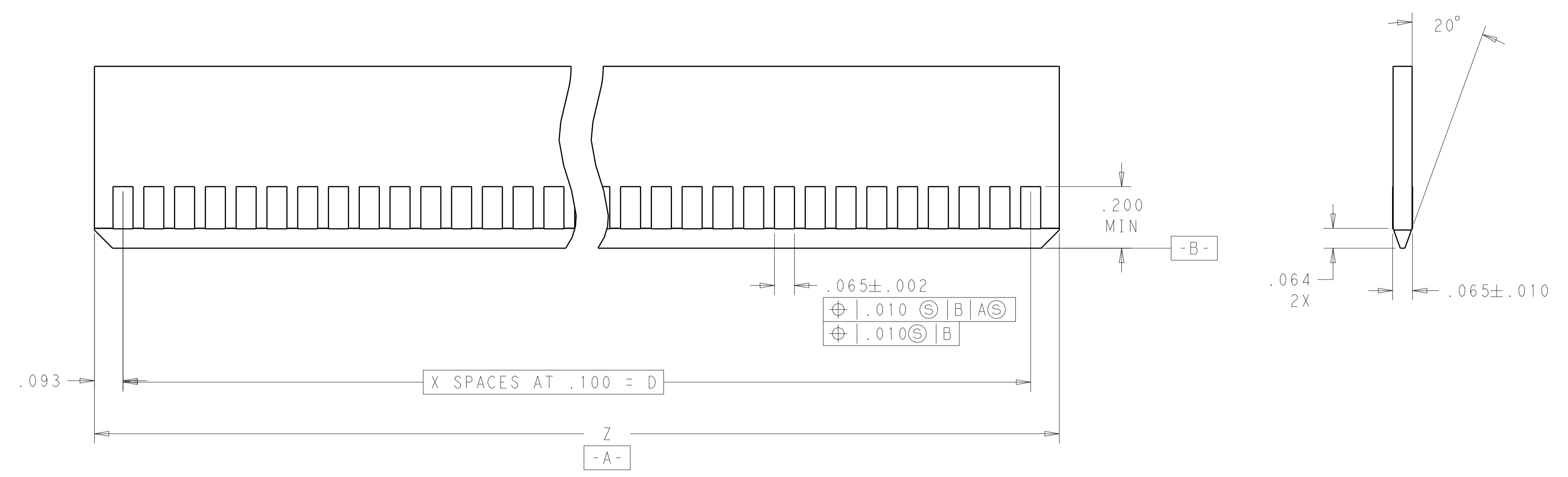

RECOMMENDED MAIN BOARD EDGE CONFIGURATION

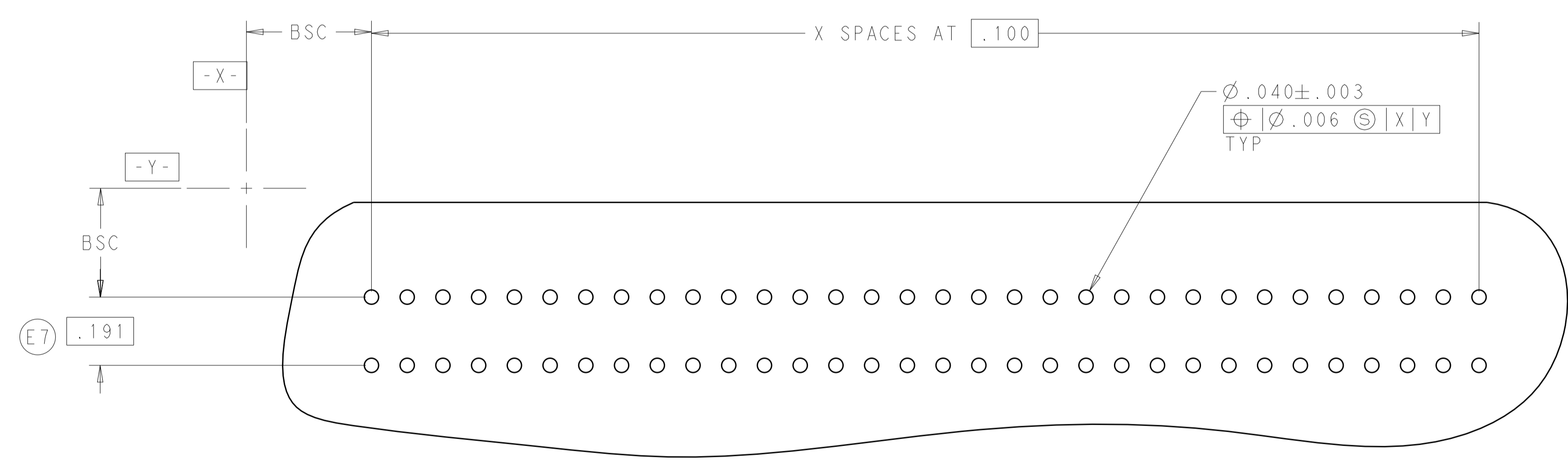

RECOMMENDED PC BOARD HOLE LAYOUT

THIS DRAWING IS A CONTROLLED DOCUMENT.		DWN: AWF/GRZYBOWSKI	30OCT2009	TE Connectivity
DIMENSIONS: INCHES		CHK: E. HOWARD	APVD: M. PERCHERK	
TOLERANCES UNLESS OTHERWISE SPECIFIED: 0 PLC ± 1 PLC ±.005 2 PLC ± 3 PLC ± 4 PLC ± ANGLES ±#2		NAME: M. PERCHERK	30OCT2009	PRODUCT SPEC: 108-9039 APPLICATION SPEC: 114-13018
MATERIAL: -		FINISH: -	WEIGHT: -	SIZE: A1 CAGE CODE: 00779 DRAWING NO: C=5530843
CUSTOMER DRAWING		SCALE: 4:1	SHEET: 4 OF 4	REV: F8



Компания «ЭлектроПласт» предлагает заключение долгосрочных отношений при поставках импортных электронных компонентов на взаимовыгодных условиях!

Наши преимущества:

- Оперативные поставки широкого спектра электронных компонентов отечественного и импортного производства напрямую от производителей и с крупнейших мировых складов;
- Поставка более 17-ти миллионов наименований электронных компонентов;
- Поставка сложных, дефицитных, либо снятых с производства позиций;
- Оперативные сроки поставки под заказ (от 5 рабочих дней);
- Экспресс доставка в любую точку России;
- Техническая поддержка проекта, помощь в подборе аналогов, поставка прототипов;
- Система менеджмента качества сертифицирована по Международному стандарту ISO 9001;
- Лицензия ФСБ на осуществление работ с использованием сведений, составляющих государственную тайну;
- Поставка специализированных компонентов (Xilinx, Altera, Analog Devices, Intersil, Interpoint, Microsemi, Aeroflex, Peregrine, Syfer, Eurofarad, Texas Instrument, Miteq, Cobham, E2V, MA-COM, Hittite, Mini-Circuits, General Dynamics и др.);

Помимо этого, одним из направлений компании «ЭлектроПласт» является направление «Источники питания». Мы предлагаем Вам помощь Конструкторского отдела:

- Подбор оптимального решения, техническое обоснование при выборе компонента;
- Подбор аналогов;
- Консультации по применению компонента;
- Поставка образцов и прототипов;
- Техническая поддержка проекта;
- Защита от снятия компонента с производства.



Как с нами связаться

Телефон: 8 (812) 309 58 32 (многоканальный)

Факс: 8 (812) 320-02-42

Электронная почта: org@eplast1.ru

Адрес: 198099, г. Санкт-Петербург, ул. Калинина, дом 2, корпус 4, литера А.