

AXL E PB DI16 M12 6M

**Axioline E PROFIBUS device, metal housing,
16 inputs, 24 V DC,
M12 fast connection technology**



Data sheet
8431_en_03

© PHOENIX CONTACT 2015-09-03

1 Description

The Axioline E device is designed for use within a PROFIBUS network.

It is used to acquire and output digital signals.

The device is designed for use in systems manufacturing.

It is suitable for use without a control cabinet under harsh industrial conditions.

The Axioline E device can be used on tool platforms, directly on welding robots or in conveying technology, for example.

PROFIBUS features

- Connection to PROFIBUS DP using M12 connectors (B-coded)
- DP/V1 for Class 1 and Class 2 masters
- Data transmission speed of 9.6 kbps up to 12 Mbps (automatic detection)
- Rotary encoding switches for setting the PROFIBUS address
- Supported PROFIBUS addresses 0 to 126
- PROFIBUS features: Sync mode, Freeze mode, I & M functions
- Device description using GSD file

Axioline E features

- Connection of digital sensors using M12 connectors (A-coded)
- Diagnostic and status indicators
- Short-circuit and overload protection of the sensor supply
- IP65/67 degree of protection



This data sheet is only valid in association with the associated user manual.



Make sure you always use the latest documentation.
It can be downloaded from the product at phoenixcontact.net/products.

2	Table of contents	
1	Description	1
2	Table of contents	2
3	Ordering data	3
4	Technical data	3
5	Internal circuit diagram	6
6	Pin assignment	7
6.1	PROFIBUS and power supply connection	7
6.2	PROFIBUS pin assignment	7
6.3	Pin assignment of the power supply U_S/U_A	8
6.4	Input connection	8
6.5	Pin assignment of the inputs	8
7	Connection example	9
8	Connection notes	9
9	Configuration via rotary encoding switch	10
10	Local status and diagnostic indicators	11
10.1	Indicators for bus and power supply	11
10.2	Input indicators	12
11	Process data	13
11.1	Assignment of the terminal points to the IN process data	13
11.2	Status module	13
12	Parameterization	13
13	I&M functions	14
14	Sync/freeze mode	15
15	Diagnostic alarms	15

3 Ordering data

Description	Type	Order No.	Pcs./Pkt.
Axioline E PROFIBUS device in a metal housing with 16 digital inputs, 24 V DC, M12 fast connection technology	AXL E PB DI16 M12 6M	2701505	1
Accessories			
An M12 screw plug for the unoccupied M12 sockets of the sensor/actuator cable, boxes and flush-type connectors (Protection and sealing elements)	PROT-M12	1680539	5
Bus system T-plug, PROFIBUS, M12 B-coded male plug to M12 B-coded male plug and M12 B-coded female plug, shielded (Connector/Adapter)	SAC-M12T/2XM12 PB DP	1507780	1
Terminating resistor PROFIBUS M12 (Connector/Adapter)	SAC-5P-M12MS PB TR	1507803	5
Mounting plate for Axioline E metal devices (Assembly)	AXL E MP 60	2701761	1
Snap-in markers, Sheet, white, unlabeled, can be labeled with: THERMOMARK CARD, BLUEMARK CLED, BLUEMARK LED, TOPMARK LASER, Mounting type: snapped into marker carrier, Lettering field: 7 x 10 mm (Marking)	UCT-EM (7X10)	0830765	10
Documentation			
User manual, English, Axioline E: system and installation	UM EN AXL E SYS INST	-	-
Application note, English, Startup of Axioline E PROFIBUS devices on a SIMATIC® S7 controller (for experienced S7 users)	AH EN S7 - AXL E PB PRO	-	-

Additional ordering data

For additional accessories, visit phoenixcontact.net/products.

4 Technical data

Dimensions (nominal sizes in mm)

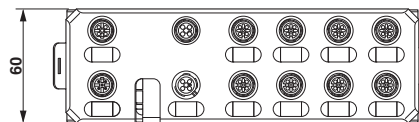
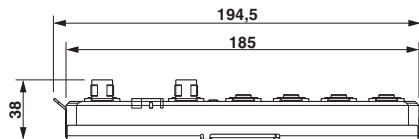

Width	60 mm
Height	185 mm
Depth	38 mm
Note on dimensions	The height is 194.5 mm including the mounting plate. With fixing clips pulled out, the height is 212 mm. The depth is 38 mm including the mounting plate (30.5 mm without the mounting plate).

General data

Housing material	Zinc die-cast
Weight	750 g
Ambient temperature (operation)	-25 °C ... 60 °C



CAUTION: Risk of burns

If the device is used at an ambient temperature above 50°C, the contact temperature of metal surfaces may exceed 70°C.

Ambient temperature (storage/transport)	-25 °C ... 85 °C
Permissible humidity (operation)	5 % ... 95 %
Permissible humidity (storage/transport)	5 % ... 95 %
Air pressure (operation)	70 kPa ... 106 kPa (up to 3000 m above sea level)
Air pressure (storage/transport)	70 kPa ... 106 kPa (up to 3000 m above sea level)
Degree of protection	IP65/IP67
Protection class	III, IEC 61140, EN 61140, VDE 0140-1

Connection data

Connection method	M12 connector
-------------------	---------------

Interface PROFIBUS DP

Number	2
Connection method	2x M12 connectors, B-coded
Designation connection point	Copper cable
Number of positions	5
Transmission speed	9,6 kBit/s ... 12 MBit/s (Automatic baud rate detection)
Transmission physics	PROFIBUS-DP-compliant copper cable

PROFIBUS DP

Equipment type	PROFIBUS slave
PROFIBUS protocols	DP V1

Supply: Module electronics and sensors (U_S)

Connection method	M12 connector (T-coded)
Number of positions	4
Supply voltage	24 V DC
Nominal supply voltage range	18 V DC ... 31.2 V DC (including all tolerances, including ripple)
Typical current consumption	165 mA ±15 % (at 24 V DC)
Current consumption	max. 12 A

Supply: Actuators (U_A) for additional devices

Connection method	M12 connector (T-coded)
Number of positions	4
Supply voltage	24 V DC
Nominal supply voltage range	18 V DC ... 31.2 V DC (including all tolerances, including ripple)
Typical current consumption	3 mA ±15 % (at 24 V DC)
Current consumption	max. 12 A

Digital inputs

Number of inputs	16 (EN 61131-2 types 1 and 3)
Connection method	M12 connector, double occupancy
Connection method	2, 3, 4-wire
Nominal input voltage	24 V DC
Nominal input current	typ. 3 mA
Sensor current per channel	typ. 0.75 mA (from U_S)
Total sensor current	max. 1.2 A (per device)
Input voltage range "0" signal	-30 V DC ... 5 V DC
Input voltage range "1" signal	11 V DC ... 30 V DC
Input filter time	< 1000 μ s
Permissible conductor length to the sensor	30 m
Overload protection, short-circuit protection of sensor supply	Yes

Configuration data

ID number	0E5C
Input address area	16 Bit
Output address area	0 Bit

Electrical isolation/isolation of the voltage areas

Test section	Test voltage
24 V supply (communications power and sensor supply, digital inputs)/ bus connection	500 V AC, 50 Hz, 1 min
24 V supply (communications power and sensor supply, digital inputs)/FE Bus connection / FE	500 V AC, 50 Hz, 1 min
24 V supply (actuator supply)/ 24 V supply (communications power and sensor supply, digital inputs)	500 V AC, 50 Hz, 1 min
24 V supply (actuator supply)/bus connection	500 V AC, 50 Hz, 1 min
24 V supply (actuator supply)/FE	500 V AC, 50 Hz, 1 min

Mechanical tests

Vibration resistance in acc. with EN 60068-2-6/IEC 60068-2-6	5g
Shock in acc. with EN 60068-2-27/IEC 60068-2-27	30g, 11 ms period, half-sine shock pulse
Continuous shock according to EN 60068-2-27/IEC 60068-2-27	10g

Conformance with EMC Directive 2004/108/EC

Noise immunity test in accordance with EN 61000-6-2

Electrostatic discharge (ESD) EN 61000-4-2/IEC 61000-4-2	Criterion B; 6 kV contact discharge, 8 kV air discharge
Electromagnetic fields EN 61000-4-3/IEC 61000-4-3	Criterion A; Field intensity: 10 V/m
Fast transients (burst) EN 61000-4-4/IEC 61000-4-4	Criterion B, 2 kV
Transient surge voltage (surge) EN 61000-4-5/IEC 61000-4-5	Criterion B; DC supply lines: ± 0.5 kV/ ± 0.5 kV (symmetrical/asymmetrical)
Conducted interference EN 61000-4-6/IEC 61000-4-6	Criterion A; Test voltage 10 V

Noise emission test as per EN 61000-6-4

Radio interference properties EN 55022	Class A
--	---------

Approvals

For the latest approvals, please visit phoenixcontact.net/products.

5 Internal circuit diagram

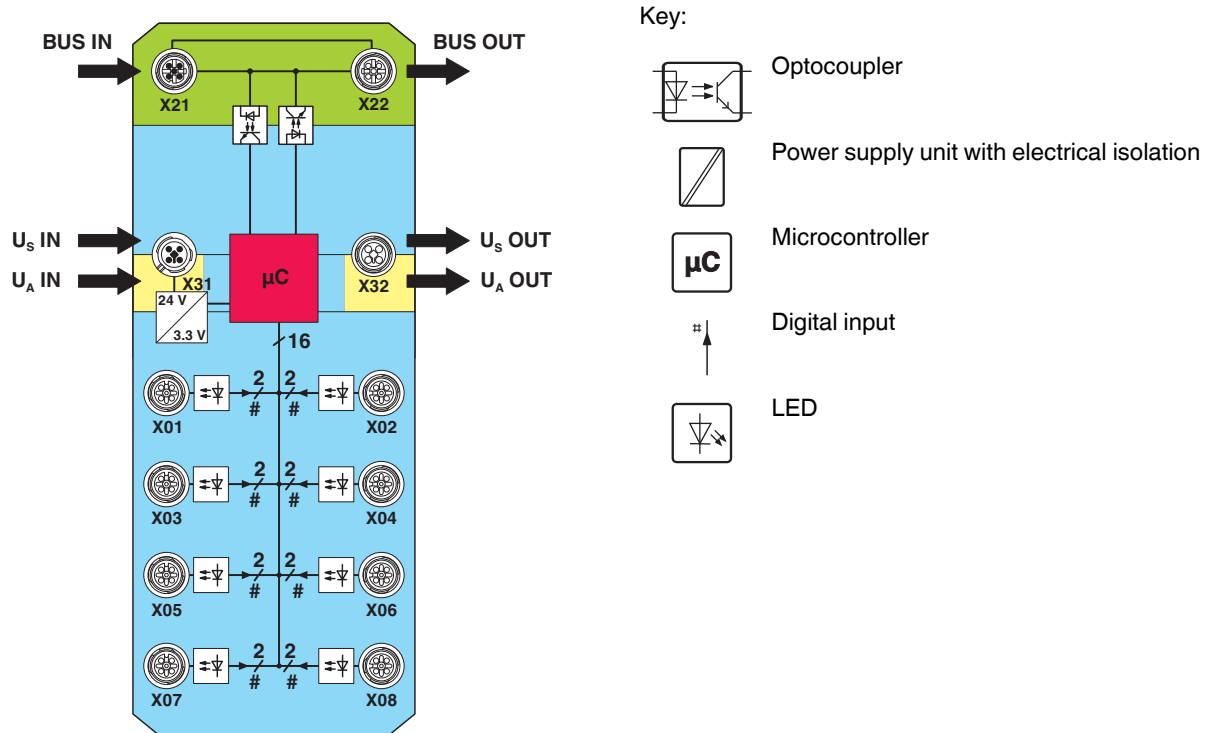

Figure 1 Internal wiring of connections

Key:

Green area: Network
 Blue area: U_S
 Yellow area: U_A

6 Pin assignment

6.1 PROFIBUS and power supply connection

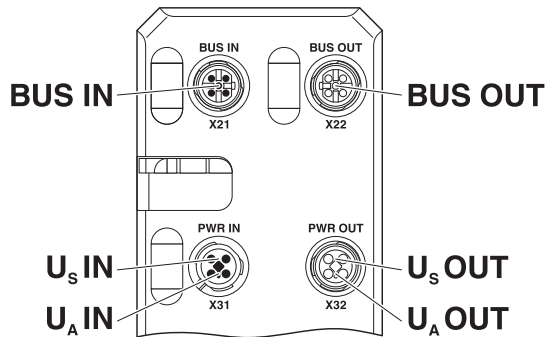

Figure 2 Connections for PROFIBUS and power supply

Designation	Meaning
BUS IN (X21)	PROFIBUS IN
BUS OUT (X22)	PROFIBUS OUT
U _S IN (X31)	Power supply IN (logic and sensors)
U _A IN (X31)	Power Supply IN (actuators) for additional devices
U _S OUT (X32)	Power supply OUT for additional devices
U _A OUT (X32)	Power supply OUT for additional devices



Ground the device by means of the mounting screws of the fixing clips or the mounting plate or the DIN rail.

6.2 PROFIBUS pin assignment

The bus is connected via two B-coded M12 plug-in plugs. The incoming bus (IN) is a plug and the outgoing bus (OUT) is a socket.

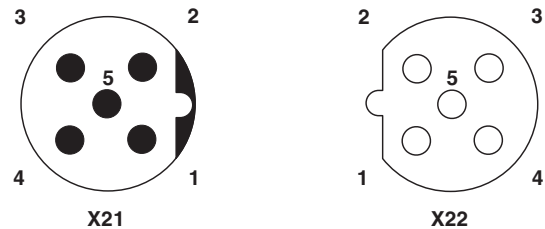

Figure 3 PROFIBUS pin assignment, B-coded

Pin	Signal	Specification	Description
1	VP	V	5 V termination resistor
2	RxD / TxD-N (A)	A, RS-485, PD	Inverted bus cable
3	DGND	V	0 V
4	RxD / TxD-P (B)	B, RS-485, PU	Non-inverted bus cable
5	Not used	-	-

- A = A line
- B = B cable
- RS-485 = RS-485 level, bidirectional
- V = Power supply
- PU = Pullup
- PD = Pulldown



The shield is connected to FE in the device.



The thread is used for additional shielding.

6.3 Pin assignment of the power supply U_S/U_A

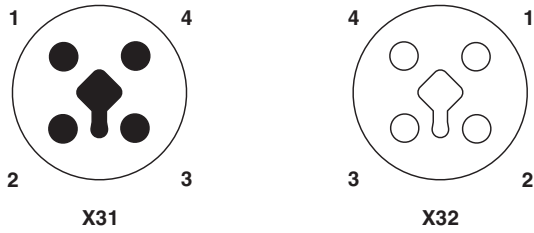

Figure 4 Pin assignment of the power supply, T-coded

Pin	IN	OUT	Conductor colors
1	+24 V DC (U_S)	+24 V DC (U_S)	Brown
2	GND (U_A)	GND (U_A)	White
3	GND (U_S)	GND (U_S)	Blue
4	+24 V DC (U_A)	+24 V DC (U_A)	Black

6.4 Input connection

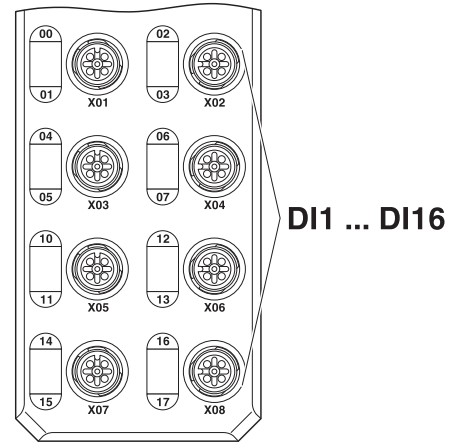

Figure 5 Input connections

Designation	Meaning
DI1 ... DI16 (X01 ... X08)	Inputs 1 ... 16

6.5 Pin assignment of the inputs

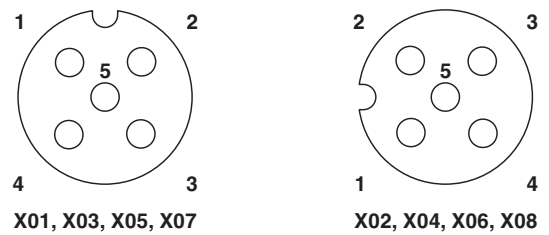

Figure 6 Pin assignment of the inputs, A-coded

Pin	Input socket
1	+24 V DC (U_S)
2	Input 2, 4, 6, ... 16
3	GND
4	Input 1, 3, 5, ... 15
5	FE

7 Connection example

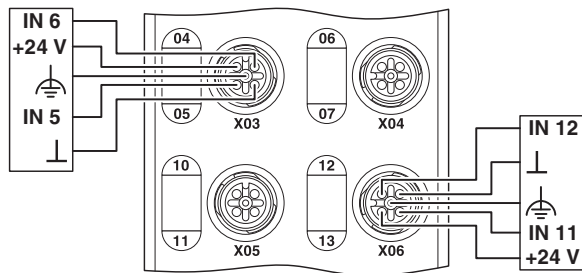

Figure 7 Typical connection of sensors

8 Connection notes



Note: data corruption or loss

Implement the FE connection using mounting screws, in order to ensure immunity to interference.



NOTE: device damage

To ensure IP65/IP67 protection, cover unused sockets with protective caps.



NOTE: Damage to the electronics

Only supply the sensors with the voltage U_S provided at the terminal points.



NOTE: Damage to the electronics

Observe the correct polarity of the supply voltages U_S and U_A in order to prevent damage to the device.



NOTE: Malfunction

When connecting the sensors, observe the assignment of the connections to the PROFIBUS input data.



Secure the device to a level surface or to a profile. Do not use this device to bridge gaps, in order to prevent forces being transmitted via the device.



Use standard M5 screws with toothed lock washer and self-locking nuts. Observe the maximum torque of the screws.

9 Configuration via rotary encoding switch

Addresses are set using two rotary coding switches. Switch x10 is used to set the position in tens (x10) and switch x1 is used to set the position in units (x1). The address can be set between 1 and 126.

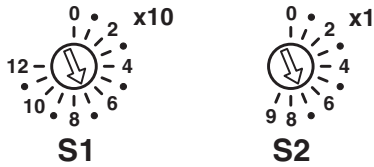

Figure 8 PROFIBUS rotary encoding switch

S1	S2	Code	Function
0	0	00	Reserved
0 ... 12	1 ... 5	01 ... 125	Manual address assignment
12	6	126	Setting the slave address (set slave address command)
12	7	127	Reserved
12	8	128	Reserved
12	9	129	Reserved



A new address value is only applied on device power up.

10 Local status and diagnostic indicators

10.1 Indicators for bus and power supply

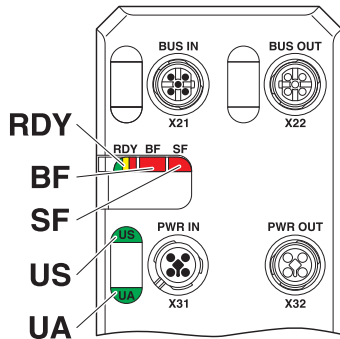

Figure 9 LEDs for bus and power supply

Designation	Color	Meaning	State	Description			
RDY	Green/ yellow/ red	Ready	Green ON	Device ready to operate			
			Yellow flashing	Firmware update is being performed.			
			Flashing green/ yellow	Over- or undervoltage at U_S Temperature of the device is in the critical area. And red US LED: sensor supply overload			
			Red ON	Rotary encoding switches are set to an invalid/reserved position.			
			OFF	Device is not ready for operation.			
			BF	Red	Bus Fault	Red ON	No communication on PROFIBUS Device is starting up. No baud rate detected by device.
SF	Red	Group error	Red flashing	Device has not been configured by the master. Device configuration does not match. Invalid parameter data received from the master. Invalid bus address The device is in the clear or stop state.			
			OFF	No error			
			Red ON	Device-specific diagnostics present, e.g., short circuit at the I/O devices. Hardware is faulty. Device data or parameter data do not match.			
			OFF	No error			
			US	Green/ red	U_{Sensorik}	Green ON	Communications power/sensor voltage present
			OFF	Communications power/sensor voltage not present or too low.			
UA	Green	U_{Aktorik}	Red ON	Sensor voltage overload			
			ON	Actuator voltage present.			
			OFF	Actuator voltage not present.			

10.2 Input indicators

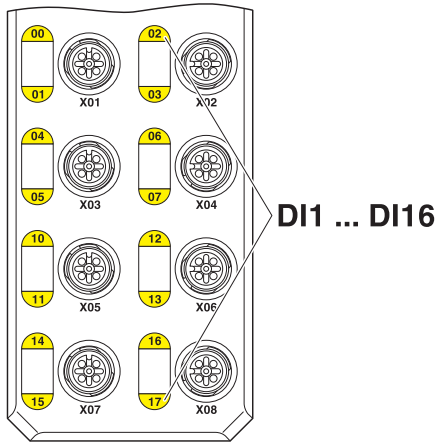

Figure 10 LEDs of the inputs

Designation	Color	Meaning	State	Description
00 ... 07, 10 ... 17	Yellow	Status of the inputs	ON	Input is set.
			OFF	Input is not set.



The numbering of the LEDs is as follows: the first number specifies the byte, the second number specifies the bit.

11 Process data

11.1 Assignment of the terminal points to the IN process data

The I/O data are mapped as follows:

Byte	Input process data															
	Byte 0								Byte 1							
Bit	7	6	5	4	3	2	1	0	7	6	5	4	3	2	1	0
IN	07	06	05	04	03	02	01	00	17	16	15	14	13	12	11	10
Connection	X04		X03		X02		X01		X08		X07		X06		X05	
Pin	2	4	2	4	2	4	2	4	2	4	2	4	2	4	2	4
DI	8	7	6	5	4	3	2	1	16	15	14	13	12	11	10	9

Key:

- Bit: Process data assignment
- IN: LED marking
- DI: Input of the device

11.2 Status module

The device has a status module in slot 1.

The status is mapped as follows.

Bit 31 ... Bit 6	Bit 5	Bit 4	Bit 3	Bit 2	Bit 1	Bit 0
Reserved	Supply of the module electronics and sensors (U_S)			Reserved		
Reserved	Undervoltage	Overload	Reserved			

12 Parameterization

This section provides a detailed description of the format of the parameters for the input devices.

This may be useful when setting parameters using acyclic services or if there is no user interface for the simple selection of parameters.

Byte	Meaning
1 ... 7	DP standard
8 ... 10	DP/V1 standard
11	Module parameter

Module parameter			
Byte	Meaning	Contents	
11	Behavior of the device	Bit 0	Reserved
		Bit 1	Reserved
		Bit 2	Byte order (Endianness)
			00 _{bin} : Motorola format (Big Endian)
		01 _{bin} : Intel format (Little Endian)	
Other	Reserved		

13 I&M functions

The following Information & Maintenance functions are supported:

I&M 0

I&M data	Access / data type	Presets
MANUFACTURER_ID	Read / 2 bytes	B0 _{hex} (Phoenix Contact GmbH & Co. KG)
ORDER_ID	Read / 20 bytes	-
SERIAL_Number	Read / 16 bytes	-
HARDWARE_Revision	Read / 2 bytes	-
SOFTWARE_Revision	Read / 4 bytes	-
REVISION_Counter	Read / 2 bytes	0000 _{hex} (reserved)
PROFILE_ID	Read / 2 bytes	F600 _{hex} (generic device)
PROFILE_SPECIFIC_TYPE	Read / 2 bytes	0003 _{hex} (IO module)
IM_VERSION	Read / 2 bytes	0102 _{hex} (Version 1.2)
IM_SUPPORTED	Read / 2 bytes	000E _{hex} (I&M 1 ... 3)

I&M 1

I&M data	Access / data type	Presets
TAG_FUNCTION	Read/write / 32 bytes	"20 _{hex} " (empty)
TAG_LOCATION	Read/write / 22 bytes	"20 _{hex} " (empty)

I&M 2

I&M data	Access / data type	Presets
INSTALLATION_DATE	Read/write / 16 bytes	"20 _{hex} " (empty)
RESERVED	Read/write / 38 bytes	0 _{hex}

I&M 3

I&M data	Access / data type	Presets
DESCRIPTOR	Read/write / 54 bytes	"20 _{hex} " (empty)

14 Sync/freeze mode

The device supports sync and freeze mode.

The functions must be activated by the PROFIBUS master in the parameter data.

Input and output data is written or read at defined times with the sync and freeze commands.

If the device receives a sync command from the PROFIBUS master at any given time, the current OUT process data is transferred and frozen until the next sync command.

Similarly, the states of the inputs are transferred on the respective freeze command and are frozen until the next freeze command.

15 Diagnostic alarms

PROFIBUS enables the PROFIBUS device to store diagnostic information together with the error location and error type.

In the default upon delivery the alarms are enabled, however, they can be disabled with parameters on startup.

An incoming alarm informs the PROFIBUS device that diagnostic information has been entered.

When the diagnostic information has been removed, an outgoing alarm is sent to the device.

If at least one piece of diagnostic information is stored, the SF LED is on. If no diagnostic information is present, the SF LED is off.

The following PROFIBUS diagnostic messages are indicated by the PROFIBUS device:

- Overtemperature of the device
- Surge voltage of U_S
- Overload of U_S



Компания «ЭлектроПласт» предлагает заключение долгосрочных отношений при поставках импортных электронных компонентов на взаимовыгодных условиях!

Наши преимущества:

- Оперативные поставки широкого спектра электронных компонентов отечественного и импортного производства напрямую от производителей и с крупнейших мировых складов;
- Поставка более 17-ти миллионов наименований электронных компонентов;
- Поставка сложных, дефицитных, либо снятых с производства позиций;
- Оперативные сроки поставки под заказ (от 5 рабочих дней);
- Экспресс доставка в любую точку России;
- Техническая поддержка проекта, помощь в подборе аналогов, поставка прототипов;
- Система менеджмента качества сертифицирована по Международному стандарту ISO 9001;
- Лицензия ФСБ на осуществление работ с использованием сведений, составляющих государственную тайну;
- Поставка специализированных компонентов (Xilinx, Altera, Analog Devices, Intersil, Interpoint, Microsemi, Aeroflex, Peregrine, Syfer, Eurofarad, Texas Instrument, Miteq, Cobham, E2V, MA-COM, Hittite, Mini-Circuits, General Dynamics и др.);

Помимо этого, одним из направлений компании «ЭлектроПласт» является направление «Источники питания». Мы предлагаем Вам помощь Конструкторского отдела:

- Подбор оптимального решения, техническое обоснование при выборе компонента;
- Подбор аналогов;
- Консультации по применению компонента;
- Поставка образцов и прототипов;
- Техническая поддержка проекта;
- Защита от снятия компонента с производства.



Как с нами связаться

Телефон: 8 (812) 309 58 32 (многоканальный)

Факс: 8 (812) 320-02-42

Электронная почта: org@eplast1.ru

Адрес: 198099, г. Санкт-Петербург, ул. Калинина, дом 2, корпус 4, литера А.