



**SMSC**<sup>®</sup>  
SUCCESS BY DESIGN

**USB332x**



## Industry's Smallest Hi-Speed USB Transceiver with 1.8V ULPI Interface

### PRODUCT FEATURES

Data Brief

- Integrated ESD protection circuits
  - Up to  $\pm 15$ kV IEC Air Discharge without external devices
- Over-Voltage Protection circuit (OVP) protects the VBUS pin from continuous DC voltages up to 30V
- Integrated USB Switch
  - No degradation of Hi-Speed electrical characteristics
  - Allows single USB port of connection by providing switching function for:
    - Battery charging
    - Stereo and mono/mic audio
    - USB Full-Speed/Low-Speed data
- flexPWR<sup>™</sup> Technology
  - Low current design ideal for battery powered applications
  - “Sleep” mode tri-states all ULPI pins and places the part in a low current state
  - 1.8V IO Voltage ( $\pm 10\%$ )
- Integrated battery to 3.3V LDO regulator
  - 2.2 $\mu$ F bypass capacitor
  - 100mV dropout voltage
- “Wrapper-less” design for optimal timing performance and design ease
  - Low Latency Hi-Speed Receiver (43 Hi-Speed clocks Max) allows use of legacy UTMI Links with a ULPI bridge
- External Reference Clock operation
  - 0 to 3.6V input drive tolerant
  - Able to accept “noisy” clock sources as reference to internal, low-jitter PLL
  - Frequencies: 12, 13, 19.2, 24, 26, 27, 38.4, 52 or 60MHz
- Smart detection circuits allow identification of USB charger, headset, or data cable insertion
- Includes full support for the optional On-The-Go (OTG) protocol detailed in the On-The-Go Supplement Revision 1.3 specification
- Supports the OTG Host Negotiation Protocol (HNP) and Session Request Protocol (SRP)
- UART mode for non-USB serial data transfers

- Internal 5V cable short-circuit protection of ID, DP and DM lines to VBUS or ground
- Industrial Operating Temperature -40°C to +85°C
- 25 ball WLCSP lead-free RoHS compliant package; (1.95 x 1.95 x 0.53mm height)

### Applications

The USB332x is targeted for any application where a Hi-Speed USB connection is desired and when board space, power, and interface pins must be minimized.

The USB332x is well suited for:

- Cell Phones
- PDAs
- MP3 Players
- GPS Personal Navigation Devices
- Datacards
- Scanners
- External Hard Drives
- Digital Still and Video Cameras
- Portable Media Players
- Entertainment Devices
- Printers
- HDTVs
- Set Top Boxes/DVR/PVR
- Video Record/Playback Systems
- IP and Video Phones
- Gaming Consoles
- POS Terminals

**ORDER NUMBER(S):**

ORDER NUMBER	REFCLK FREQUENCY (Note 1)	PACKAGE TYPE	REEL SIZE
USB3321C-GL-TR	26MHz	25 Ball, WLCSP Lead-Free RoHS Compliant Package (tape and reel)	3000 pieces
USB3322C-GL-TR	12MHz		
USB3324C-GL-TR	52MHz		
USB3325C-GL-TR	24MHz		
USB3326C-GL-TR	19.2MHz		
USB3327C-GL-TR	27MHz		
USB3328C-GL-TR	38.4MHz		
USB3329C-GL-TR	13MHz		

**Note 1** All versions support ULPI Clock In Mode (60MHz input at REFCLK).



80 ARKAY DRIVE, HAUPPAUGE, NY 11788 (631) 435-6000, FAX (631) 273-3123

Copyright © 2008 SMSC or its subsidiaries. All rights reserved.

Circuit diagrams and other information relating to SMSC products are included as a means of illustrating typical applications. Consequently, complete information sufficient for construction purposes is not necessarily given. Although the information has been checked and is believed to be accurate, no responsibility is assumed for inaccuracies. SMSC reserves the right to make changes to specifications and product descriptions at any time without notice. Contact your local SMSC sales office to obtain the latest specifications before placing your product order. The provision of this information does not convey to the purchaser of the described semiconductor devices any licenses under any patent rights or other intellectual property rights of SMSC or others. All sales are expressly conditional on your agreement to the terms and conditions of the most recently dated version of SMSC's standard Terms of Sale Agreement dated before the date of your order (the "Terms of Sale Agreement"). The product may contain design defects or errors known as anomalies which may cause the product's functions to deviate from published specifications. Anomaly sheets are available upon request. SMSC products are not designed, intended, authorized or warranted for use in any life support or other application where product failure could cause or contribute to personal injury or severe property damage. Any and all such uses without prior written approval of an Officer of SMSC and further testing and/or modification will be fully at the risk of the customer. Copies of this document or other SMSC literature, as well as the Terms of Sale Agreement, may be obtained by visiting SMSC's website at <http://www.smSC.com>. SMSC is a registered trademark of Standard Microsystems Corporation ("SMSC"). Product names and company names are the trademarks of their respective holders.

**SMSC DISCLAIMS AND EXCLUDES ANY AND ALL WARRANTIES, INCLUDING WITHOUT LIMITATION ANY AND ALL IMPLIED WARRANTIES OF MERCHANTABILITY, FITNESS FOR A PARTICULAR PURPOSE, TITLE, AND AGAINST INFRINGEMENT AND THE LIKE, AND ANY AND ALL WARRANTIES ARISING FROM ANY COURSE OF DEALING OR USAGE OF TRADE. IN NO EVENT SHALL SMSC BE LIABLE FOR ANY DIRECT, INCIDENTAL, INDIRECT, SPECIAL, PUNITIVE, OR CONSEQUENTIAL DAMAGES; OR FOR LOST DATA, PROFITS, SAVINGS OR REVENUES OF ANY KIND; REGARDLESS OF THE FORM OF ACTION, WHETHER BASED ON CONTRACT; TORT; NEGLIGENCE OF SMSC OR OTHERS; STRICT LIABILITY; BREACH OF WARRANTY; OR OTHERWISE; WHETHER OR NOT ANY REMEDY OF BUYER IS HELD TO HAVE FAILED OF ITS ESSENTIAL PURPOSE, AND WHETHER OR NOT SMSC HAS BEEN ADVISED OF THE POSSIBILITY OF SUCH DAMAGES.**

# General Description

SMSC's USB332x is a family of Hi-Speed USB 2.0 Transceivers that provides a physical layer (PHY) solution well-suited for portable electronic devices. Both commercial and industrial temperature applications are supported.

Each model in the USB332x family may use a 60MHz reference clock, or the model-number specific reference clock shown in [ORDER NUMBER\(S\)](#): on page 2.

Several advanced features make the USB332x the transceiver of choice by reducing both electrical bill of material (eBOM) part count and printed circuit board (PCB) area. Outstanding ESD robustness eliminates the need for external ESD protection devices in typical applications. The internal Over-Voltage Protection circuit (OVP) protects the USB332x from voltages up to 30V. By using a reference clock from the Link, the USB332x removes the cost of a dedicated crystal reference from the design. And the integrated USB switch enables unique product features with a single USB port of connection.

The USB332x meets all of the electrical requirements to be used as a Hi-Speed USB Host, Device, or an On-the-Go (OTG) transceiver. In addition to the supporting USB signaling, the USB332x also provides USB UART mode and USB Audio mode.

USB332x uses the industry standard UTMI+ Low Pin Interface (ULPI) to connect the USB PHY to the Link. ULPI uses a method of in-band signaling and status byte transfers between the Link and PHY to facilitate a USB session with only 12 pins.

The USB332x uses SMSC's "wrapper-less" technology to implement the ULPI interface. This "wrapper-less" technology allows the PHY to achieve a low latency transmit and receive time. SMSC's low latency transceiver allows an existing UTMI Link to be reused by adding a UTMI to ULPI bridge. By adding a bridge to the ASIC the existing and proven UTMI Link IP can be reused.

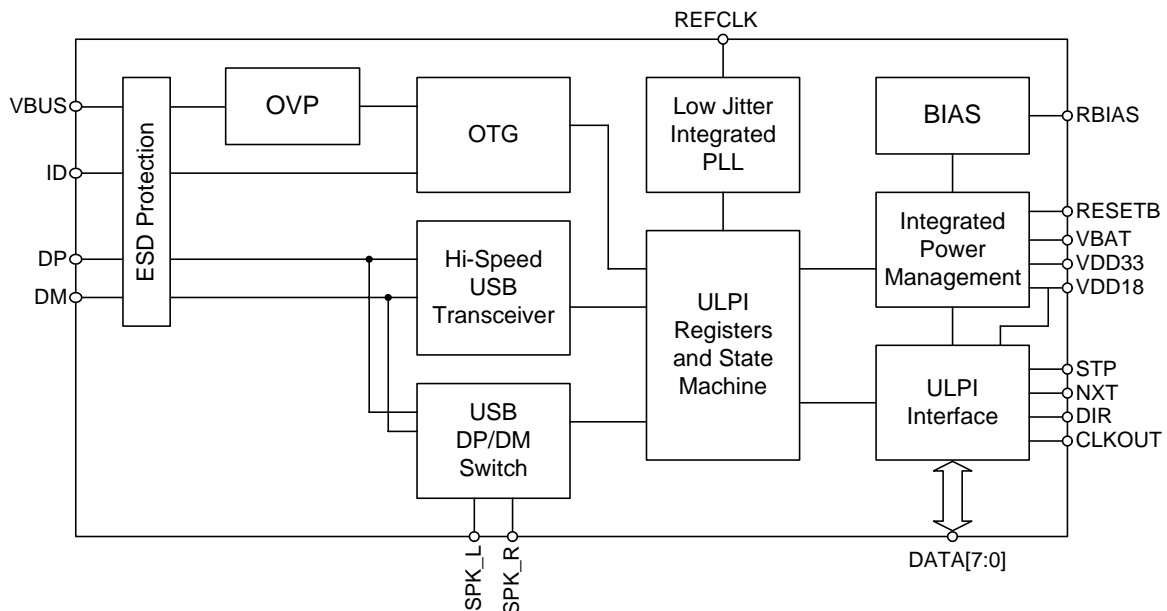

Figure 1 USB332x Block Diagram

The USB332x includes an integrated 3.3V LDO regulator that may optionally be used to generate 3.3V from power applied at the **VBAT** pin. The voltage on the **VBAT** pin can range from 3.1 to 5.5V. The regulator dropout voltage is less than 100mV which allows the PHY to continue USB signaling when the voltage on **VBAT** drops to 3.1V. The USB transceiver will continue to operate at lower voltages, although some parameters may be outside the limits of the USB specifications. If the user would like to provide a 3.3V supply to the USB332x, the **VBAT** and **VDD33** pins should be connected together.

The USB332x also includes integrated pull-up resistors that can be used for detecting the attachment of a USB Charger. By sensing the attachment to a USB Charger, a product using the USB332x can charge its battery at more than the 500mA allowed when charging from a USB Host.

In USB UART mode, the USB332x **DP** and **DM** pins are redefined to enable pass-through of asynchronous serial data. The USB332x can only enter UART mode when the user programs the part into this mode.

In USB audio mode, a switch connects the **DP** pin to the **SPK\_R** pin, and another switch connects the **DM** pin to the **SPK\_L** pin. The USB332x can be configured to enter USB audio mode. In addition, these switches are on when the **RESETB** pin of the USB332x is asserted. The USB audio mode enables audio signalling from a single USB port of connection, and the switches may also be used to connect Full Speed USB from another PHY onto the USB cable.

## USB332x Pin Locations and Descriptions

### Package Diagram with Ball Locations

The illustration below is viewed from the top of the package.

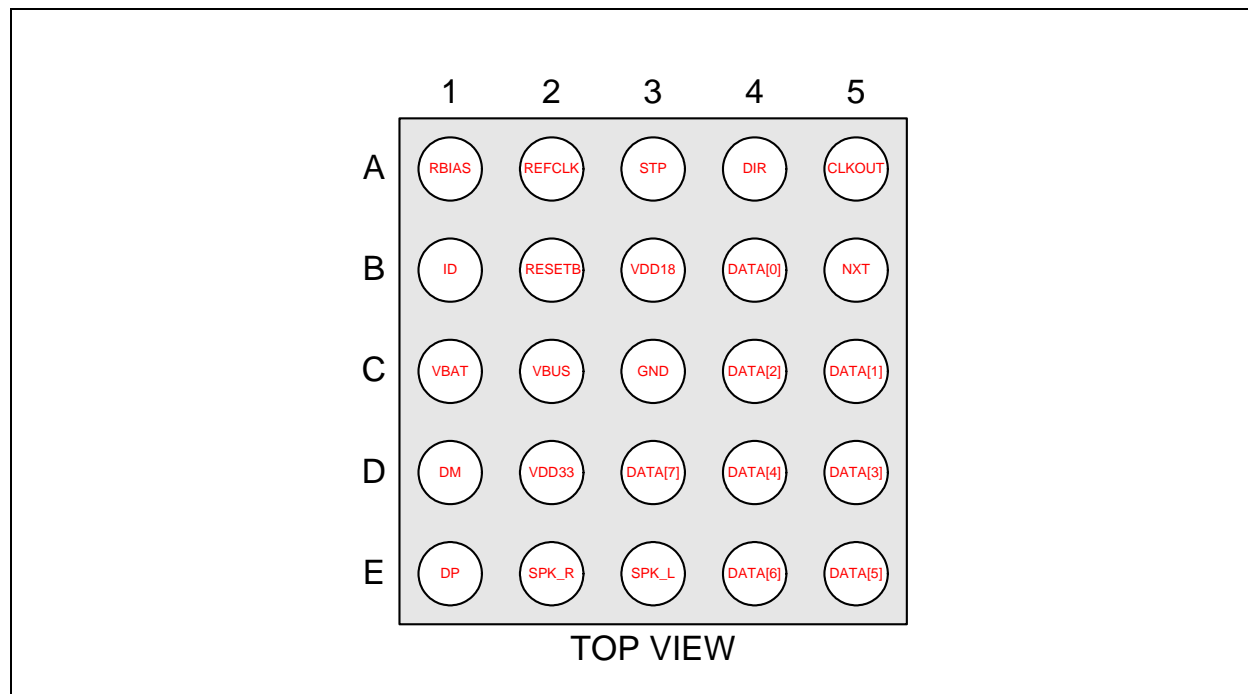

Figure 2 USB332x Ball Locations - Top View

### Ball Definitions

The following table details the ball definitions for the figure above.

Table 1 USB332x Pin Description

BALL	NAME	DIRECTION/ TYPE	ACTIVE LEVEL	DESCRIPTION
B1	ID	Input, Analog	N/A	<b>ID</b> pin of the USB cable. For applications not using ID this pin can be connected to <b>VDD33</b> . For an A-Device <b>ID</b> is grounded. For a B-Device <b>ID</b> is floated.
C2	VBUS	I/O, Analog	N/A	This pin connects to an external resistor ( $R_{VBUS}$ ) connected to the VBUS pin of the USB cable. This pin is used for the VBUS comparator inputs and for VBUS pulsing during session request protocol.
C1	VBAT	Power	N/A	Regulator input. The regulator supply can be from 5.5V to 3.1V.

Table 1 USB332x Pin Description (continued)

BALL	NAME	DIRECTION/ TYPE	ACTIVE LEVEL	DESCRIPTION
D2	VDD33	Power	N/A	3.3V Regulator Output. A 2.2uF (<1 ohm ESR) bypass capacitor to ground is required for regulator stability. The bypass capacitor should be placed as close as possible to the USB332x.
D1	DM	I/O, Analog	N/A	D- pin of the USB cable.
E1	DP	I/O, Analog	N/A	D+ pin of the USB cable.
E2	SPK_R	I/O, Analog	N/A	USB switch in/out for DP signals
E3	SPK_L	I/O, Analog	N/A	USB switch in/out for DM signals
D3	DATA[7]	I/O, CMOS	N/A	ULPI bi-directional data bus. <b>DATA[7]</b> is the MSB.
E4	DATA[6]	I/O, CMOS	N/A	ULPI bi-directional data bus.
E5	DATA[5]	I/O, CMOS	N/A	ULPI bi-directional data bus.
D4	DATA[4]	I/O, CMOS	N/A	ULPI bi-directional data bus.
A5	CLKOUT	Output, CMOS	N/A	<b>ULPI Clock Out Mode:</b> 60MHz ULPI clock output. All ULPI signals are driven synchronous to the rising edge of this clock. <b>ULPI Clock In Mode:</b> This pin is connected to VDD18 to configure 60MHz ULPI Clock IN mode.
D5	DATA[3]	I/O, CMOS	N/A	ULPI bi-directional data bus.
C4	DATA[2]	I/O, CMOS	N/A	ULPI bi-directional data bus.
C5	DATA[1]	I/O, CMOS	N/A	ULPI bi-directional data bus.
B4	DATA[0]	I/O, CMOS	N/A	ULPI bi-directional data bus. <b>DATA[0]</b> is the LSB.
B5	NXT	Output, CMOS	High	The PHY asserts <b>NXT</b> to throttle the data. When the Link is sending data to the PHY, <b>NXT</b> indicates when the current byte has been accepted by the PHY. The Link places the next byte on the data bus in the following clock cycle.
A4	DIR	Output, CMOS	N/A	Controls the direction of the data bus. When the PHY has data to transfer to the Link, it drives <b>DIR</b> high to take ownership of the bus. When the PHY has no data to transfer it drives <b>DIR</b> low and monitors the bus for commands from the Link.

**Table 1 USB332x Pin Description (continued)**

<b>BALL</b>	<b>NAME</b>	<b>DIRECTION/ TYPE</b>	<b>ACTIVE LEVEL</b>	<b>DESCRIPTION</b>
<b>A3</b>	<b>STP</b>	Input, CMOS	High	The Link asserts <b>STP</b> for one clock cycle to stop the data stream currently on the bus. If the Link is sending data to the PHY, <b>STP</b> indicates the last byte of data was on the bus in the previous cycle.
<b>B3</b>	<b>VDD18</b>	Power	N/A	External 1.8V Supply input pin. This pad needs to be bypassed with a 0.1uF capacitor to ground, placed as close as possible to the USB332x.
<b>B2</b>	<b>RESETB</b>	Input, CMOS,	Low	When low, the part is suspended with all ULPI outputs tri-stated. When high, the USB332x will operate as a normal ULPI device. The state of this pin may be changed asynchronously to the clock signals. When asserted for a minimum of 1 microsecond and then de-asserted, the ULPI registers are reset to their default state and all internal state machines are reset.
<b>A2</b>	<b>REFCLK</b>	Input, CMOS	N/A	<b>ULPI Clock Out Mode:</b> Model-specific reference clock. See <a href="#">ORDER NUMBER(S)</a> : on page 2. <b>ULPI Clock In Mode:</b> 60MHz ULPI clock input.
<b>A1</b>	<b>RBIAS</b>	Analog, CMOS	N/A	Bias Resistor pin. This pin requires an 8.06k $\Omega$ ( $\pm$ 1%) resistor to ground, placed as close as possible to the USB332x. Nominal voltage during ULPI operation is 0.8V.
<b>C3</b>	<b>GND</b>	Ground	N/A	Ground.

# Application Diagrams

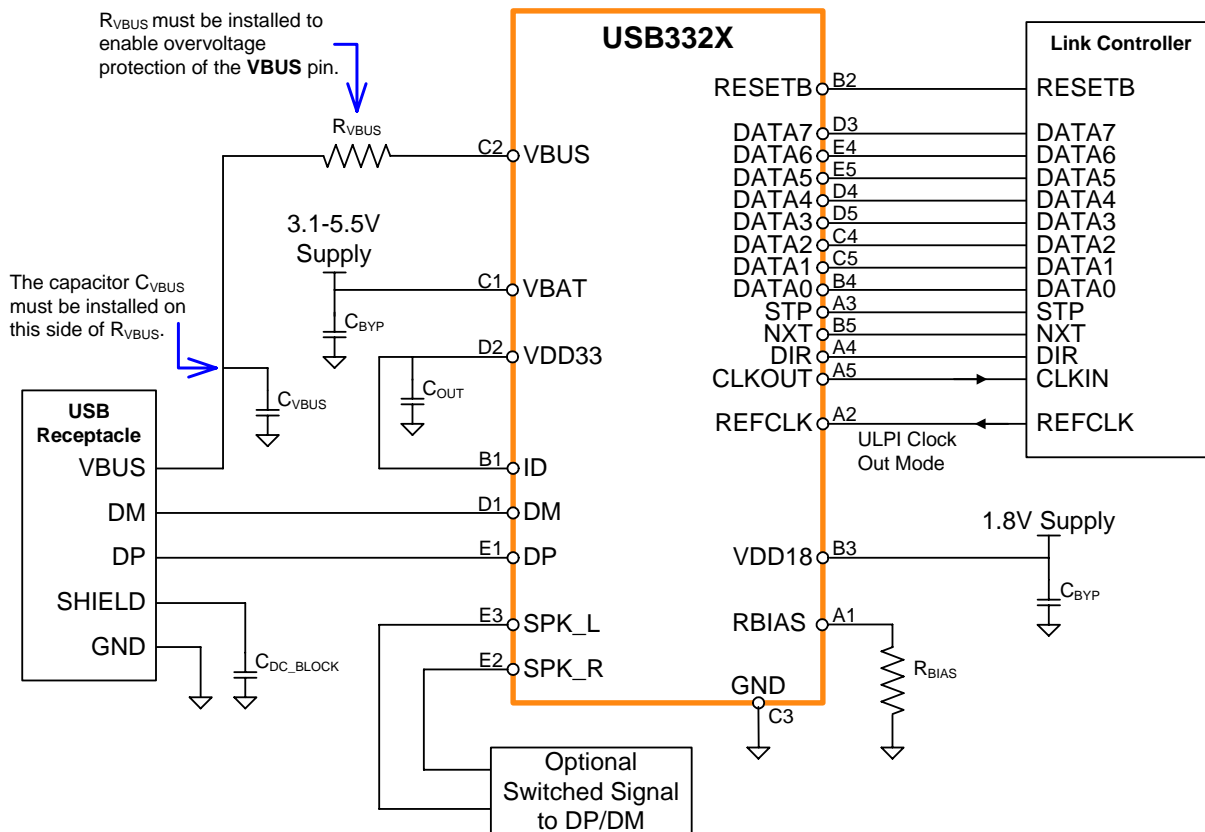

Figure 3 USB332x WLCSP Application Diagram (Device configured for ULPI Clock Out mode)



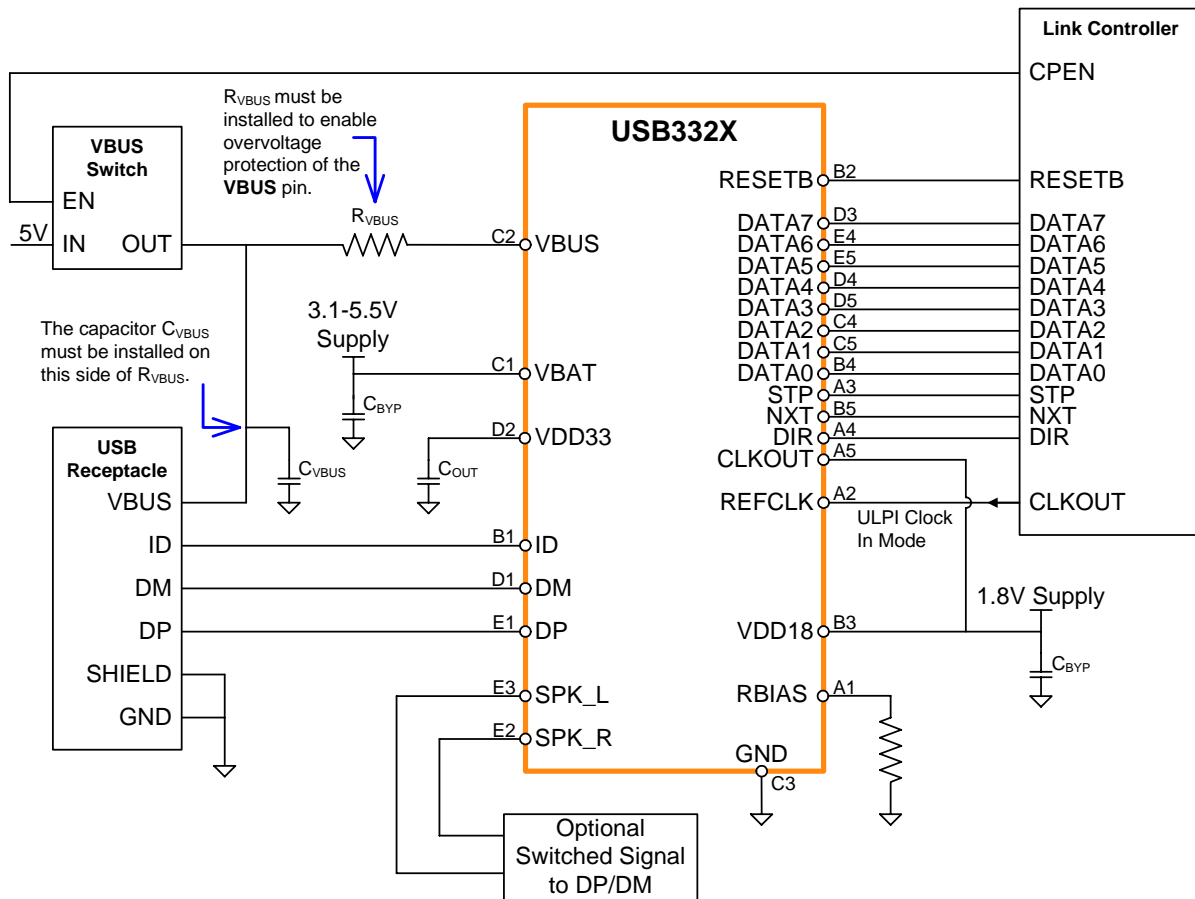
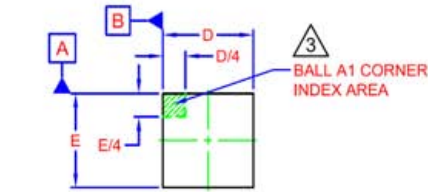
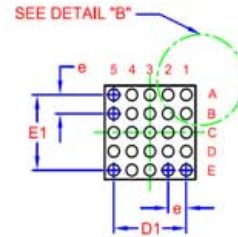

Figure 4 USB332x WLCSP Application Diagram (Host or OTG configured for ULPI Clock In mode)

# Package Outline



TOP VIEW



BOTTOM VIEW

COMMON DIMENSIONS					
SYMBOL	MIN	NOM	MAX	NOTE	REMARK
A	-	0.53	0.62	5	OVERALL PACKAGE HEIGHT
A1	0.16	-	0.24	-	STANDOFF
A2	-	-	0.38	6	PACKAGE THICKNESS
D/E	1.93	-	1.97	-	X/Y DIE SIZE
D1/E1	1.60 BSC		-	-	X/Y END BALLS DISTANCE
b	0.20	0.25	0.30	2	BALL DIAMETER
e	0.40 BSC		-	-	BALL PITCH
ccc	0	-	0.05	4	COPLANARITY

**NOTES:**

1. ALL DIMENSIONS ARE IN MILLIMETERS.
2. DIMENSION "b" IS MEASURED AT THE MAXIMUM BALL DIAMETER, PARALLEL TO PRIMARY DATUM "C".
3. THE BALL "A1" CORNER MUST BE IDENTIFIED IN THE INDICATED AREA OF THE TOP PACKAGE SURFACE.
4. PRIMARY DATUM "C" AND SEATING PLANE ARE DEFINED BY THE SPHERICAL CROWNS OF THE CONTACT SOLDER BALLS.
5. DIMENSION "A" DOES NOT INCLUDE ATTACHED EXTERNAL FEATURES, SUCH AS HEAT SINK OR CHIP CAPACITORS. DIMENSION "A(MAX)" IS GIVEN FOR THE EXTREMELY THIN VARIATION OF THE PACKAGE PROFILE HEIGHT.
6. DIMENSION "A2" INCLUDES A DIE COATING THICKNESS.

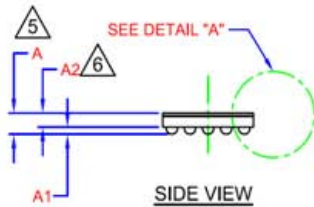

SIDE VIEW

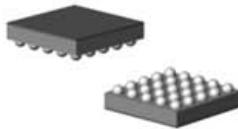

3-D VIEWS

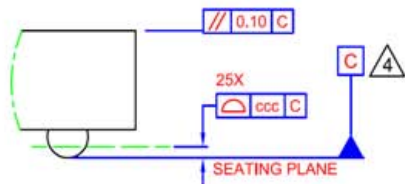

DETAIL A

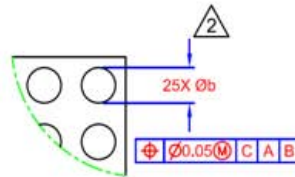

DETAIL B

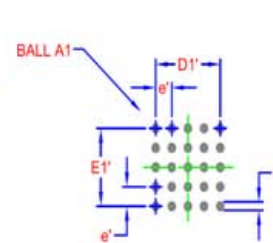

LAND PATTERN DIMENSIONS			
SYMBOL	MIN	NOM	MAX
D1'/E1'	-	1.60	-
b'	0.15	-	0.20
e'	-	0.40	-

THE USER MAY MODIFY THE PCB LAND PATTERN DIMENSIONS, BASED ON THEIR EXPERIENCE AND/OR PROCESS CAPABILITY

RECOMMENDED PCB LAND PATTERN

Figure 5 25WLCSP, 1.95x1.95mm Body, 0.4mm Pitch



Компания «ЭлектроПласт» предлагает заключение долгосрочных отношений при поставках импортных электронных компонентов на взаимовыгодных условиях!

Наши преимущества:

- Оперативные поставки широкого спектра электронных компонентов отечественного и импортного производства напрямую от производителей и с крупнейших мировых складов;
- Поставка более 17-ти миллионов наименований электронных компонентов;
- Поставка сложных, дефицитных, либо снятых с производства позиций;
- Оперативные сроки поставки под заказ (от 5 рабочих дней);
- Экспресс доставка в любую точку России;
- Техническая поддержка проекта, помощь в подборе аналогов, поставка прототипов;
- Система менеджмента качества сертифицирована по Международному стандарту ISO 9001;
- Лицензия ФСБ на осуществление работ с использованием сведений, составляющих государственную тайну;
- Поставка специализированных компонентов (Xilinx, Altera, Analog Devices, Intersil, Interpoint, Microsemi, Aeroflex, Peregrine, Syfer, Eurofarad, Texas Instrument, Miteq, Cobham, E2V, MA-COM, Hittite, Mini-Circuits, General Dynamics и др.);

Помимо этого, одним из направлений компании «ЭлектроПласт» является направление «Источники питания». Мы предлагаем Вам помощь Конструкторского отдела:

- Подбор оптимального решения, техническое обоснование при выборе компонента;
- Подбор аналогов;
- Консультации по применению компонента;
- Поставка образцов и прототипов;
- Техническая поддержка проекта;
- Защита от снятия компонента с производства.



#### Как с нами связаться

**Телефон:** 8 (812) 309 58 32 (многоканальный)

**Факс:** 8 (812) 320-02-42

**Электронная почта:** [org@eplast1.ru](mailto:org@eplast1.ru)

**Адрес:** 198099, г. Санкт-Петербург, ул. Калинина, дом 2, корпус 4, литера А.