

SSL - Discrete Wire IDC



Series 9175



The 917X series of surface mount Insulation Displacement Connectors (IDC) were developed to meet the harsh automotive and industrial market applications for connecting individual wires directly to a PCB ranging from 14 AWG to 28 AWG. This industry proven contact system has been tested to automotive levels of shock, vibration, and temperature cycling to prove their reliability and robustness. The simplicity of inserting a wire into the connector with a small tool allows a wide range of devices to be connected to the PCB without soldering. In SSL applications specifically, these connectors are used to bring power and signal onto the PCB or are used to daisy chain multiple boards together in a long string. While the IDC contact provides a gas-tight connection to conductor of the wire, the housing has been designed to grab the insulation of the wire to provide a positive strain relief even in the harshest conditions. In case of repair, the wires can be removed and replace up to three times.

The 9175 series accepts 26 AWG to 28 AWG wires with an insulation diameter ranging from 0.7mm to 1.0mm. These single contact connectors support a 1 amp current rating and have a split SMT tail design to provide maximum stability on the PCB. Available in a 2p and 3p configuration, these connectors can be end stackable for higher pin counts.

APPLICATIONS

- Connecting discrete wire components directly to the PCB
- Bringing power and signals onto a PCB
- Daisy chaining PCB's together to create a continuous string of boards
- Application Notes: refer to 201-01-124

FEATURES AND BENEFITS

- IDC contact provides a gas-tight connection to the PCB for long term reliability
- Connector housing captures the wire insulation for positive strain relief
- Tested to automotive levels on shock, vibration and temperature cycling for reliability
- Low and high volume assembly tools to match production volumes
- Reduced total applied cost versus solder or crimp processes
- High temperature insulator capable to 260 degrees C reflow soldering processes

ELECTRICAL

- Current Rating: 1 Amp / Contact
- Voltage Rating: 125 VAC

ENVIRONMENTAL

- Operating Temperature: -40°C to +125°C

MECHANICAL

- Insulator Material: Nylon 46: UL94V0
- Contact Material: Phosphor Bronze
- Plating: Tin over Nickel
- Durability: 3 Cycles

HOW TO ORDER

00	9175	00X									
Prefix	Series	Number of Ways									
		<table border="1"> <thead> <tr> <th>Code</th> <th>No of Ways</th> <th>Details</th> </tr> </thead> <tbody> <tr> <td>002</td> <td>2</td> <td>Page 39</td> </tr> <tr> <td>003</td> <td>3</td> <td>Page 40</td> </tr> </tbody> </table>	Code	No of Ways	Details	002	2	Page 39	003	3	Page 40
Code	No of Ways	Details									
002	2	Page 39									
003	3	Page 40									

001									
Wire Gauge Size									
<table border="1"> <thead> <tr> <th>Code</th> <th>Accepted Wire Gauge</th> <th>Wire Insulation</th> </tr> </thead> <tbody> <tr> <td>001</td> <td>28 Gauge Solid or Stranded</td> <td>Min Ø 0.70</td> </tr> <tr> <td></td> <td>26 Gauge Solid or Stranded</td> <td>Max Ø 1.00</td> </tr> </tbody> </table>	Code	Accepted Wire Gauge	Wire Insulation	001	28 Gauge Solid or Stranded	Min Ø 0.70		26 Gauge Solid or Stranded	Max Ø 1.00
Code	Accepted Wire Gauge	Wire Insulation							
001	28 Gauge Solid or Stranded	Min Ø 0.70							
	26 Gauge Solid or Stranded	Max Ø 1.00							

X									
Insulator Color									
<table border="1"> <thead> <tr> <th>Code</th> <th>Color</th> <th>Application</th> </tr> </thead> <tbody> <tr> <td>0</td> <td>Black</td> <td>Industrial</td> </tr> <tr> <td>1</td> <td>White</td> <td>Lighting</td> </tr> </tbody> </table>	Code	Color	Application	0	Black	Industrial	1	White	Lighting
Code	Color	Application							
0	Black	Industrial							
1	White	Lighting							

06
Plating Option
06 = Pure Tin all over

Certification: UL File #E320991



SSL - Discrete Wire IDC



Series 9175

26-28 AWG 2 WAY IDC CONNECTOR

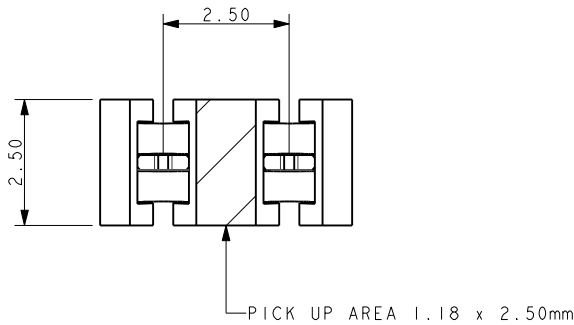

NOTES:

1. CONNECTOR FOR IDC WIRE TO BOARD CONNECTION.
2. CONTACT MATERIAL: PHOSPHORE BRONZE.
INSULATION MATERIAL: HIGH TEMPERATURE NYLON 46.
COLOR REFER TO PAGE 38.
3. CONNECTOR DESIGNED TO ACCEPT 26 AND 28 GAUGE SOLID OR STRANDED WIRE.
4. ALL DIMENSIONS FOR REFERENCE UNLESS OTHERWISE STATED.
5. FOR FULL PRODUCT SPECIFICATION REFER TO ELCO SPEC 201-01-100.

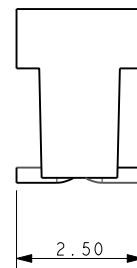
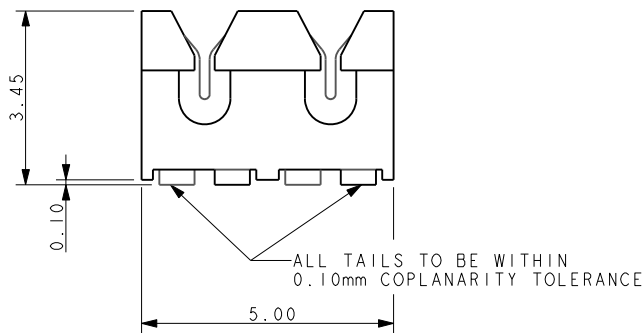

SMT PCB LAYOUT

PURE TIN PADS

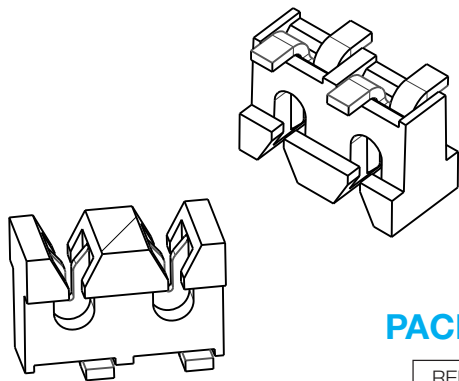
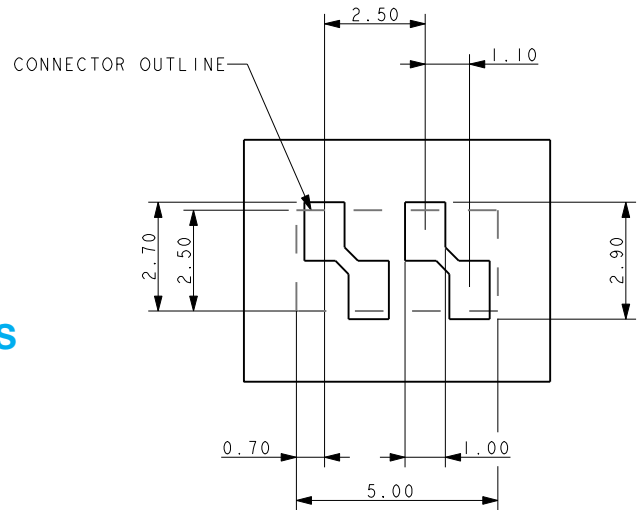

PACKING DETAILS

REEL QTY	2000
LEADER	500MM
TRAILER	500MM
REEL / BOX	7
PACK QTY	14000

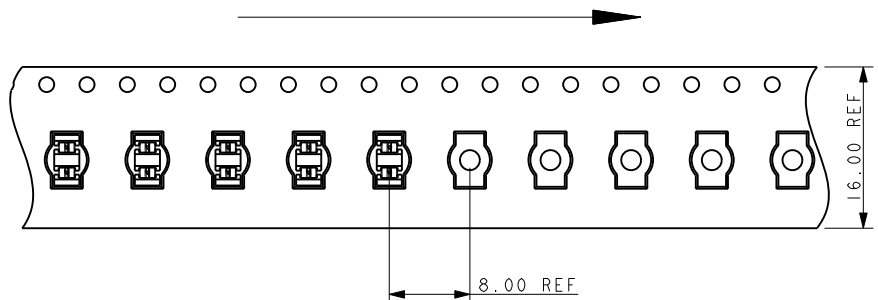
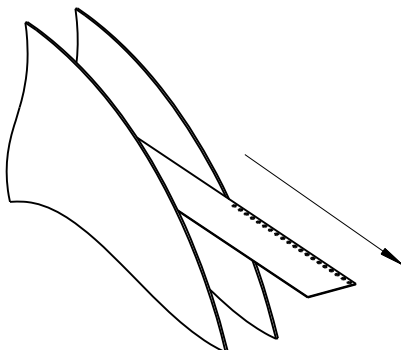

SSL - Discrete Wire IDC



Series 9175

26-28 AWG 3 WAY IDC CONNECTOR



NOTES:

1. CONNECTOR FOR IDC WIRE TO BOARD CONNECTION.
2. CONTACT MATERIAL: PHOSPHORE BRONZE.
INSULATION MATERIAL: HIGH TEMPERATURE NYLON 46.
COLOR REFER TO PAGE 38.
3. CONNECTOR DESIGNED TO ACCEPT 26 AND 28 GAUGE SOLID OR STRANDED WIRE.
4. ALL DIMENSIONS FOR REFERENCE UNLESS OTHERWISE STATED.
5. FOR FULL PRODUCT SPECIFICATION REFER TO ELCO SPEC 201-01-100.

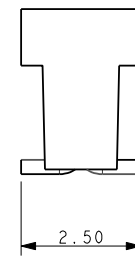
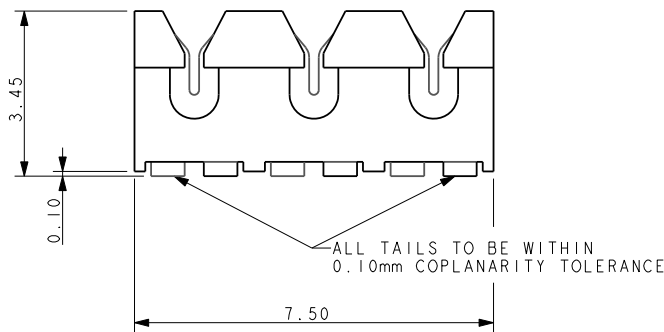

SMT PCB LAYOUT

PURE TIN PADS

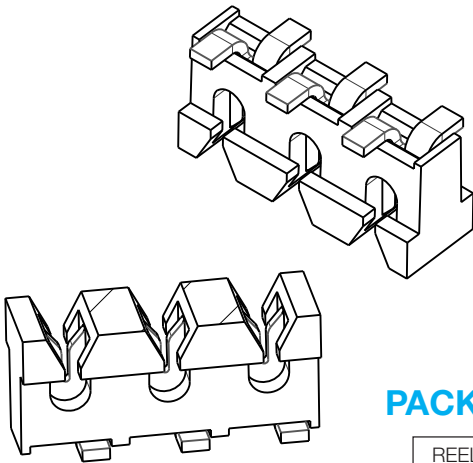
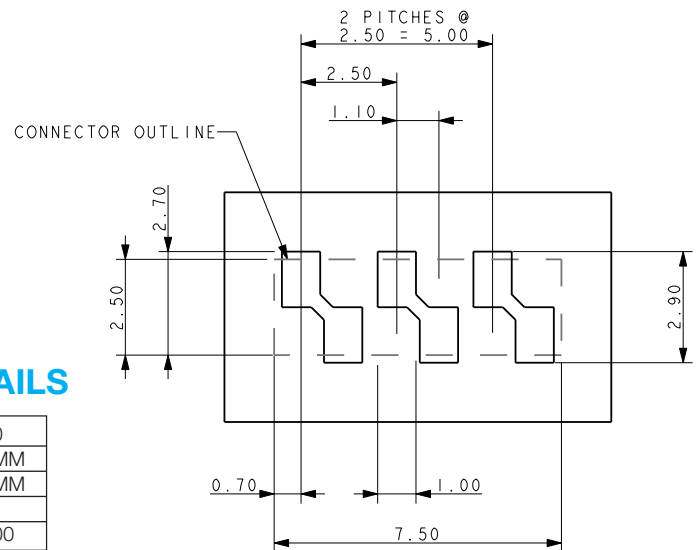

PACKING DETAILS

REEL QTY	2000
LEADER	500MM
TRAILER	500MM
REEL / BOX	7
PACK QTY	14000

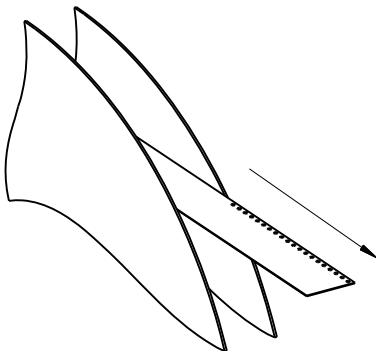

SSL - Discrete Wire IDC



Series 9175

HAND INSERTION TOOLING SINGLE WIRE INSERTION TOOL FOR 26/28 GAUGE WIRE



UNIVERSAL HANDLE

Details	Tool Part Number
6.35 A/F HEX BIT HOLDER	06 7000 7730 01 000

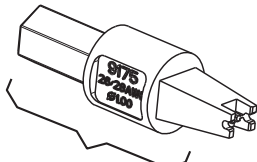

ALL METAL

HIGH PRODUCTION Metal

Max Insulation Dia	Tool Part Number
∅ 1.00	06 9175 7017 01 000



METAL SHANK

PLASTIC

MED PRODUCTION Metal/Plastic

Max Insulation Dia	Tool Part Number
∅ 1.00	06 9175 7016 01 000

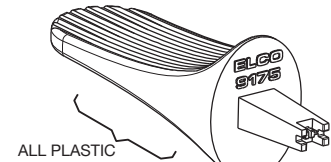

ALL PLASTIC

LOW PRODUCTION Plastic

Max Insulation Dia	Tool Part Number
∅ 1.00	06 9175 7004 01 000

CLEARANCE AREA ON PCB FOR HAND TOOLING

2 WAY

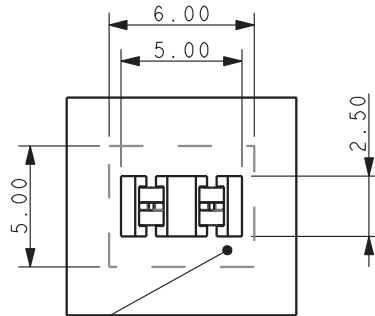

AREA TO BE KEPT CLEAR FOR TOOLING

3 WAY

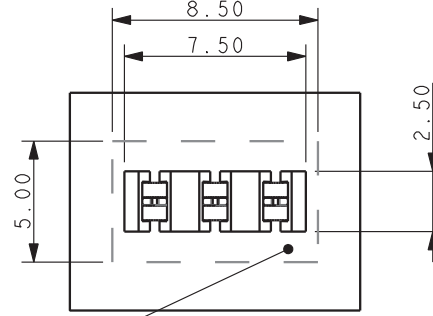

AREA TO BE KEPT CLEAR FOR TOOLING

INSERTION TOOLING REQUIRES HAND PRESS WITH FLAT ROCK PLATES

2 WAY TOOL

TOOL NUMBER 06-9175-7017-01-002

SKETCH SHOWS PCB RESTRICTED AREAS FOR ASSEMBLY TOOLING

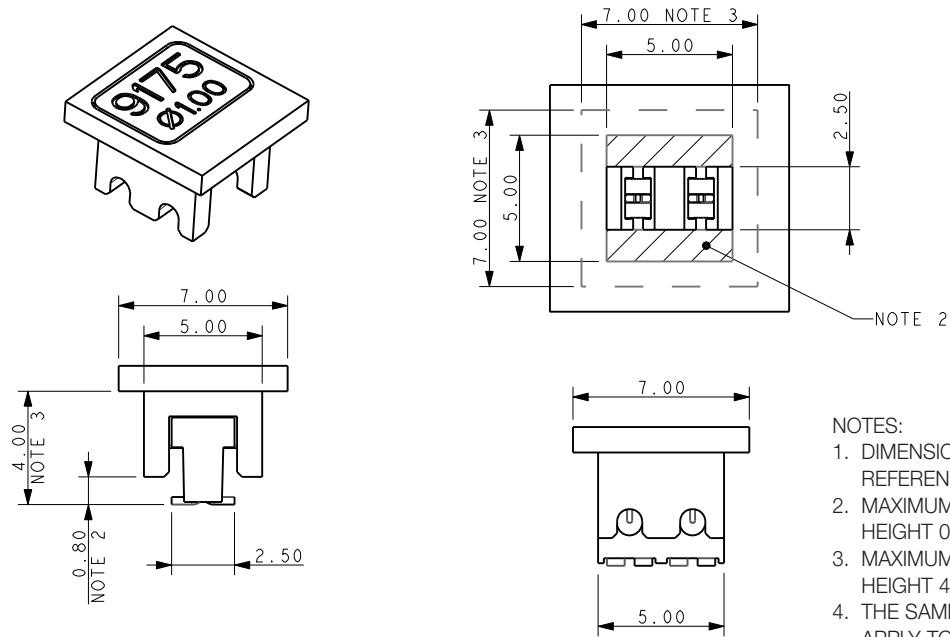

NOTES:

1. DIMENSIONS SHOWN ARE REFERENCE DIMENSIONS.
2. MAXIMUM COMPONENT HEIGHT 0.80MM IN THIS AREA.
3. MAXIMUM COMPONENT HEIGHT 4.00MM IN THIS AREA.
4. THE SAME RESTRICTIONS APPLY TO ALL WIRE INSULATION DIAMETERS.

3 WAY TOOL

TOOL NUMBER 06-9175-7017-01-003

SKETCH SHOWS PCB RESTRICTED AREAS FOR ASSEMBLY TOOLING

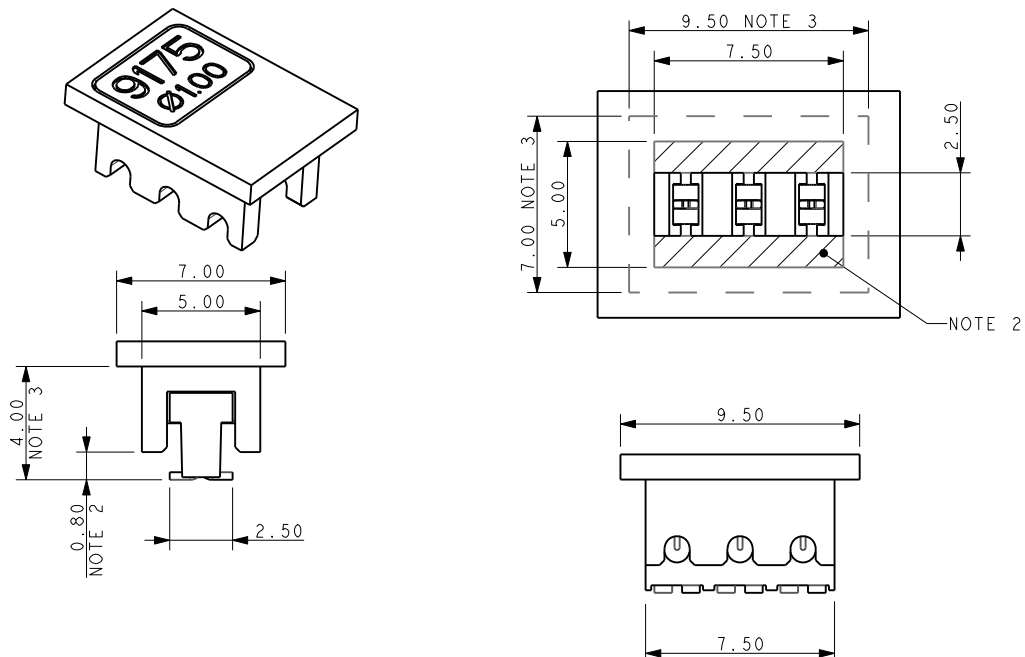



Компания «ЭлектроПласт» предлагает заключение долгосрочных отношений при поставках импортных электронных компонентов на взаимовыгодных условиях!

Наши преимущества:

- Оперативные поставки широкого спектра электронных компонентов отечественного и импортного производства напрямую от производителей и с крупнейших мировых складов;
- Поставка более 17-ти миллионов наименований электронных компонентов;
- Поставка сложных, дефицитных, либо снятых с производства позиций;
- Оперативные сроки поставки под заказ (от 5 рабочих дней);
- Экспресс доставка в любую точку России;
- Техническая поддержка проекта, помощь в подборе аналогов, поставка прототипов;
- Система менеджмента качества сертифицирована по Международному стандарту ISO 9001;
- Лицензия ФСБ на осуществление работ с использованием сведений, составляющих государственную тайну;
- Поставка специализированных компонентов (Xilinx, Altera, Analog Devices, Intersil, Interpoint, Microsemi, Aeroflex, Peregrine, Syfer, Eurofarad, Texas Instrument, Miteq, Cobham, E2V, MA-COM, Hittite, Mini-Circuits, General Dynamics и др.);

Помимо этого, одним из направлений компании «ЭлектроПласт» является направление «Источники питания». Мы предлагаем Вам помощь Конструкторского отдела:

- Подбор оптимального решения, техническое обоснование при выборе компонента;
- Подбор аналогов;
- Консультации по применению компонента;
- Поставка образцов и прототипов;
- Техническая поддержка проекта;
- Защита от снятия компонента с производства.



Как с нами связаться

Телефон: 8 (812) 309 58 32 (многоканальный)

Факс: 8 (812) 320-02-42

Электронная почта: org@eplast1.ru

Адрес: 198099, г. Санкт-Петербург, ул. Калинина, дом 2, корпус 4, литера А.