

## USB-SDP-CABLEZ Serial Interface Board

### FEATURES

#### USB-to-serial interface

#### Peripherals exposed

I<sup>2</sup>C

SPI

GPIO

#### USB 2.0 PC connectivity

### GENERAL DESCRIPTION

This user guide describes the **USB-SDP-CABLEZ** serial interface board from Analog Devices, Inc. The **USB-SDP-CABLEZ** is primarily used to communicate with certain Analog Devices evaluation boards to support customer evaluation. It can also be used by customers to communicate with supported Analog Devices components on their own board, using the appropriate Analog Devices evaluation software to facilitate in-system debugging and programming as required during product development.

The primary audience for this user guide is the system engineer. This user guide describes how to set up the **USB-SDP-CABLEZ** board and begin USB communications to the PC.

The **USB-SDP-CABLEZ** provides USB connectivity through a USB 2.0 high speed connection to the computer, allowing users to evaluate components from a PC application. The **USB-SDP-CABLEZ** is based on a USB-to-serial engine, which has I<sup>2</sup>C, SPI, and GPIO lines available, with a small 10-pin connector.

This user guide provides instructions for installing the **USB-SDP-CABLEZ** hardware and software onto a computer. The necessary installation files are available to download from the **USB-SDP-CABLEZ** evaluation board page or from the evaluation tools page for the product being evaluated on <http://www.analog.com>.

The Getting Started section provides software and hardware installation procedures, PC system requirements, and basic board information. The Evaluation Board Hardware section provides information on the **USB-SDP-CABLEZ** components. The **USB-SDP-CABLEZ** schematics are provided in the Evaluation Board Schematics section.

For more information about the **USB-SDP-CABLEZ** board, go to [www.analog.com/usb-sdp-cablez](http://www.analog.com/usb-sdp-cablez).

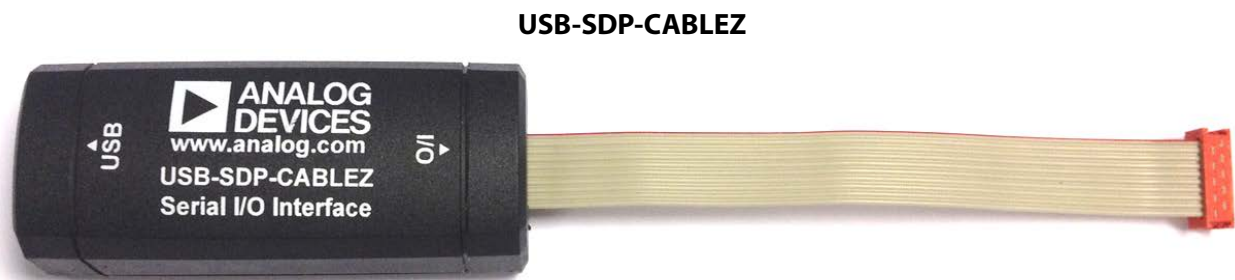

Figure 1.

10664-001

**TABLE OF CONTENTS**

Features .....	1	USB Driver Installation .....	4
General Description .....	1	Adapter Boards .....	4
USB-SDP-CABLEZ .....	1	Powering Up/Powering Down the USB-SDP-CABLEZ.....	5
Revision History .....	2	Evaluation Board Hardware.....	6
Product Overview.....	3	LEDs.....	6
Package Contents.....	3	Connector Details .....	6
Technical or Customer Support.....	3	Power.....	6
Analog Devices Website .....	3	Evaluation Board Schematics.....	8
Getting Started .....	4	Bill of Materials.....	11
PC Configuration .....	4		

**REVISION HISTORY**

**7/12—Rev. 0 to Rev. A**

Changes to Table 1 .....	7
Changes to Power LED (LED3) Section and Figure 5.....	6

**6/12—Revision 0: Initial Version**

## PRODUCT OVERVIEW

The [USB-SDP-CABLEZ](#) board includes the following:

- USB-to-serial engine
- 1 × 10-pin connector
  - AMP 10-way Micro-MaTch male connector
- Peripherals exposed
  - I<sup>2</sup>C
  - SPI
  - GPIO

## PACKAGE CONTENTS

The [USB-SDP-CABLEZ](#) board package contains the following:

- [USB-SDP-CABLEZ](#) serial interface
- 1 m USB Standard-A-to-Mini-B cable
- USB-I2C-ADPTZ adapter board (used to convert the 10-pin connector to a 3-pin I<sup>2</sup>C header)

Contact the vendor where the [USB-SDP-CABLEZ](#) board was purchased, or contact Analog Devices if anything is missing.

## TECHNICAL OR CUSTOMER SUPPORT

Analog Devices customer support can be reached in the following ways:

- Visit the EngineerZone<sup>®</sup> for community technical support at [ez.analog.com](http://ez.analog.com).
- Phone questions to 1-800-ANALOGD
- Contact your Analog Devices local sales office or authorized distributor.
- Send questions by mail to  
Analog Devices, Inc.  
Three Technology Way  
P.O. Box 9106  
Norwood, MA 02062-9106  
USA

## ANALOG DEVICES WEBSITE

The Analog Devices website, [www.analog.com](http://www.analog.com), provides information about a broad range of products: analog integrated circuits, amplifiers, converters, and digital signal processors.

Also, note that [MyAnalog.com](http://MyAnalog.com) is a free feature of the Analog Devices website that allows customization of a Web page to display only the latest information about products of interest to you. You can choose to receive weekly email notifications containing updates to the Web pages that meet your interests, including documentation errata for all documents. [MyAnalog.com](http://MyAnalog.com) provides access to books, application notes, data sheets, code examples, and more.

Visit [MyAnalog.com](http://MyAnalog.com) to sign up. If you are a registered user, simply log on. Your user name is your email address.

## GETTING STARTED

This section provides specific information to assist with using the [USB-SDP-CABLEZ](#) board as part of the user's evaluation system.

The following topics are covered:

- PC configuration
- USB installation
- Powering up/powering down the [USB-SDP-CABLEZ](#)

### PC CONFIGURATION

For correct operation of the SDP board, the user's computer must have the following minimum configuration:

- Windows XP Service Pack 2 or Windows Vista®
- USB 2.0 port

When removing the [USB-SDP-CABLEZ](#) board from the package, handle the board carefully to avoid the discharge of static electricity, which can damage some components.

### USB DRIVER INSTALLATION

Perform the following tasks to correctly install the [USB-SDP-CABLEZ](#) driver software onto the computer. The software can be obtained from [www.analog.com/usb-sdp-cablez](http://www.analog.com/usb-sdp-cablez) and is called Common Run-Time Installer. Version 2.0.0 or greater is required to operate with the [USB-SDP-CABLEZ](#).

#### Installing the Software

1. Run the setup.exe application found in the installer zip file. If running Windows XP, it may be necessary for the machine to restart shortly after the installation process begins.
2. The first part of the installer places the required Run-Time engine and software drivers for the USB-SMBUS-CABLE I<sup>2</sup>C dongle onto the PC.
3. After this, the installer for the [USB-SDP-CABLEZ](#) runs. As part of this, the .NET Framework 3.5 is installed, if not already on the PC. If the .NET Framework 3.5 is installed on the computer, this stage is skipped and only the driver package installation is installed.

#### Connecting the [USB-SDP-CABLEZ](#) Board to the PC

Attach the [USB-SDP-CABLEZ](#) board to a USB 2.0 port on the computer via the Standard-A-to-Mini-B cable provided.

#### Verifying Driver Installation

Before using the [USB-SDP-CABLEZ](#) board, verify that the driver software has installed properly.

Open the **Windows Device Manager** and verify that the [USB-SDP-CABLEZ](#) board appears under **ADI Development Tools**, as shown in Figure 2.

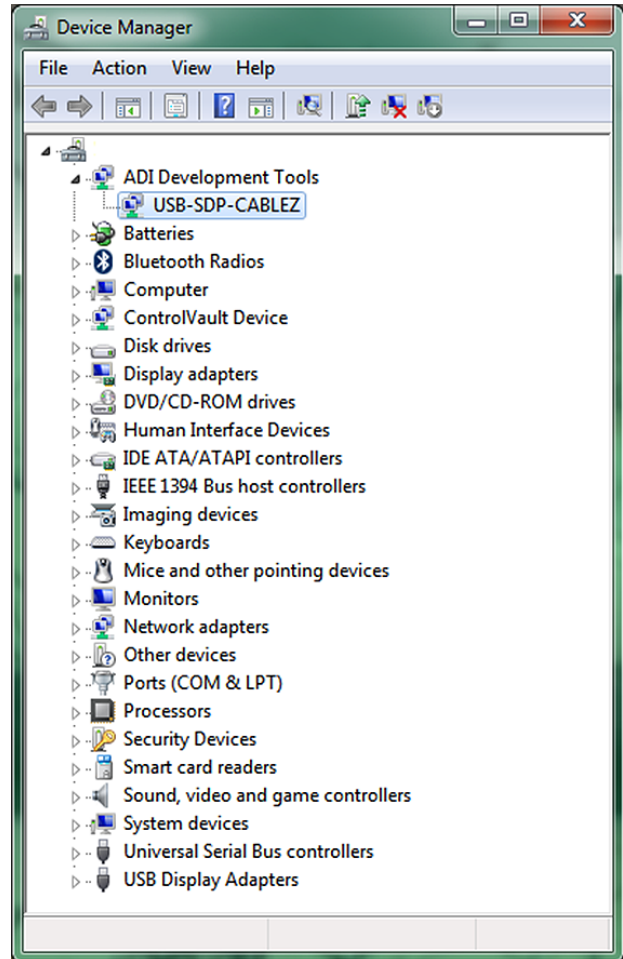

Figure 2. Device Manager

### ADAPTER BOARDS

The [USB-SDP-CABLEZ](#) uses a 10-pin Micro-MaTch male connector as its interface connector. However, some older evaluation kits use a different connector for I<sup>2</sup>C connections and require the use of an adapter board to convert the 10-pin connector to an appropriate connection.

The [USB-SDP-CABLEZ](#) is supplied with the USB-I2C-ADPTZ adapter board to convert the 10-pin Micro-MaTch connector to a 3-pin 0.1" header connector.



Figure 3. USB-I2C-ADPTZ Adapter Board

The 10-way Micro-MaTch connector is fitted to the USB-I2C-ADPTZ board as shown in Figure 3, paying attention to the polarization of the Micro-MaTch connector (indicated by the red markings on the ribbon cable) and the key on the Micro-MaTch connector.

A USB-I2C5W-ADPTZ adapter board is also available, but is not supplied with the [USB-SDP-CABLEZ](#). This board is only included in the specific evaluation kits that require it. It is connected to the Micro-MaTch connector in exactly the same way as the USB-I2C-ADPTZ.



Figure 4. USB-I2C5W-ADPTZ Adapter Board

## POWERING UP/POWERING DOWN THE USB-SDP-CABLEZ

This section describes how to safely power up and power down the [USB-SDP-CABLEZ](#).

### Powering Up the USB-SDP-CABLEZ Board

1. Connect the [USB-SDP-CABLEZ](#) board to the evaluation board through the 10-pin mating connector, using an optional adapter if required.
2. Power up the evaluation board.
3. Connect the USB port on the computer to the [USB-SDP-CABLEZ](#) board.

### Powering Down the USB-SDP-CABLEZ Board

1. Disconnect the USB port on the computer from the [USB-SDP-CABLEZ](#) board.
2. Power down the daughter evaluation board.
3. Disconnect the [USB-SDP-CABLEZ](#) board from the evaluation board.

## EVALUATION BOARD HARDWARE

This section describes the hardware design of the [USB-SDP-CABLEZ](#) board.

The following topics are covered:

- The LEDs section describes the [USB-SDP-CABLEZ](#) on-board LEDs.
- The Connector Details section details the pin assignments on the 10-pin connector.
- The Power section lists the power requirements of the [USB-SDP-CABLEZ](#) and identifies the connector power inputs and output pins.

### LEDs

There are three LEDs located on the [USB-SDP-CABLEZ](#) board (see Figure 5).

#### Power LED (LED3)

The green power LED indicates that the [USB-SDP-CABLEZ](#) board is powered up. This is not an indication of USB connectivity between the [USB-SDP-CABLEZ](#) and the PC.



Figure 5. USB-SDP-CABLEZ Board LEDs

#### LED1

This yellow LED is currently not used in normal operation, but it may turn on when the board is initially connected to USB power.

#### LED2

The red LED is used as a diagnostic tool for evaluation application developers, usually to identify a particular board when more than one [USB-SDP-CABLEZ](#) is connected to a given PC.

### CONNECTOR DETAILS

The [USB-SDP-CABLEZ](#) board provides one Micro-MaTch 10-way male connector. Through this connector, the peripheral communication interfaces of the USB-to-serial engine are exposed. The exposed peripherals are

- SPI
- I<sup>2</sup>C
- GPIO

#### Connector Pin Assignments

Table 1 lists the connector pins and identifies the functionality assigned to each connector pin on the [USB-SDP-CABLEZ](#) board.

### POWER

The [USB-SDP-CABLEZ](#) board is powered by the USB connector. Pin 4 (VBUS) of the 10-way connector is connected to the 5 V line of the USB connector, providing 5 V  $\pm$  10% as an output from the [USB-SDP-CABLEZ](#) board.

A small current can be drawn from this pin, but it should not be more than 20 mA to avoid potential problems with USB port current limiting.

Table 1. 10-Pin Connector Assignments

Pin No.	Pin Name	Description
1	I2C.SCL	I <sup>2</sup> C Serial Clock.
2	GND	Ground Connection.
3	I2C.SDA	I <sup>2</sup> C Serial Data.
4	VBUS	Voltage Bus. Connected directly to the USB 5 V supply.
5	SPI.MISO	SPI Master In, Slave Out Data.
6	GPIO	General-Purpose Input/Output.
7	SPI.SCLK	SPI Clock.
8	SPI.MOSI	SPI Master Out, Slave In Data.
9	SPI.CS.A	SPI Chip Select A.
10	GND	Ground Connection.

Table 2. 3-Pin/5-Pin Header Assignments

Pin No.	Pin Name	Description
1	SCL	I <sup>2</sup> C Serial Clock.
2	SDA	I <sup>2</sup> C Serial Data.
3	GND	Ground Connection.
4	CONV	Digital Output. Available on USB-I2C5W-ADPTZ only.
5	ALERT	Digital Input. Available on USB-I2C5W-ADPTZ only.

## EVALUATION BOARD SCHEMATICS

This section provides the schematic drawings for the following boards:

- [USB-SDP-CABLEZ](#)—USB-to-serial interface (see Figure 6).
- USB-I2C-ADPTZ and USB-I2C5W-ADPTZ—adapter boards (see Figure 7).



9000-19901

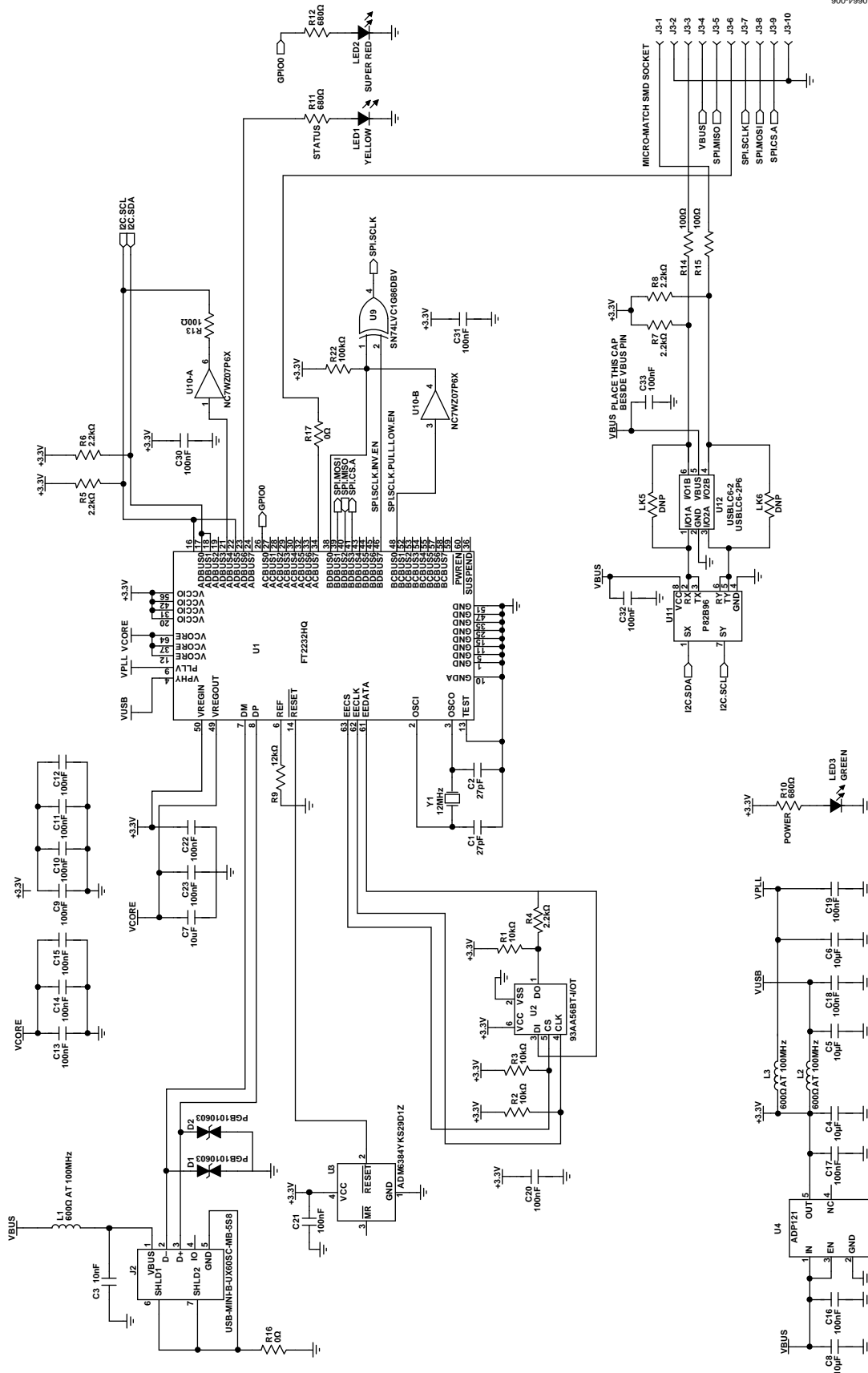

Figure 6. USB-SDP-CABLEZ—USB-to-Serial Interface

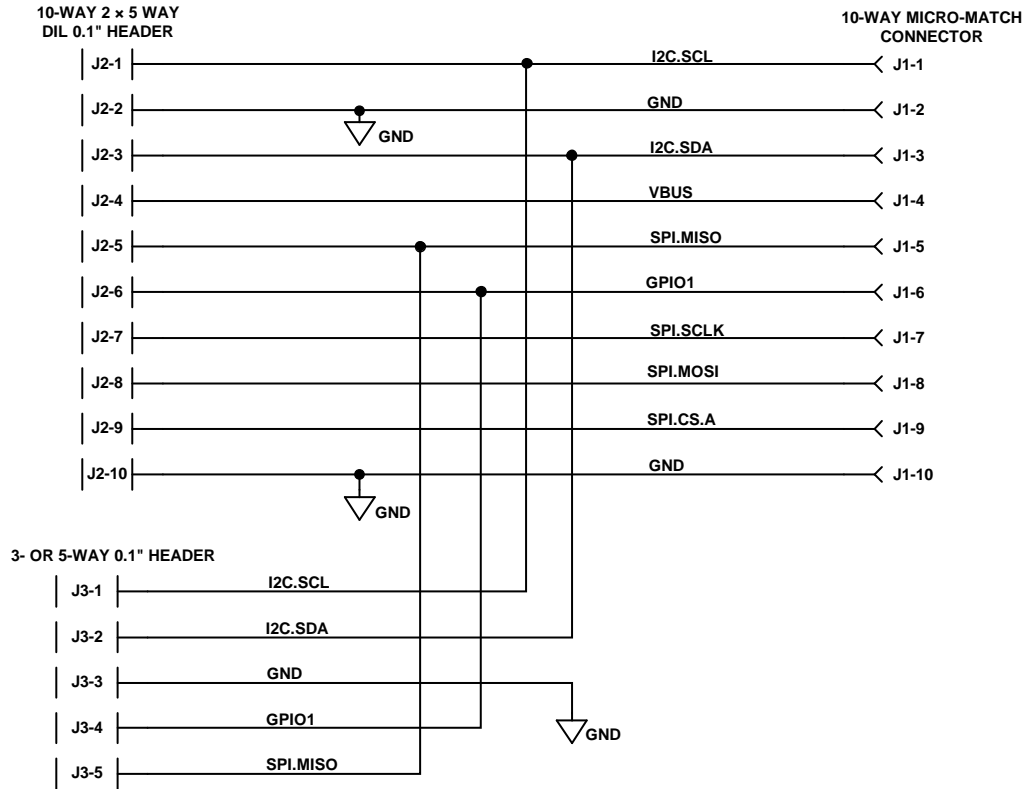

Figure 7. USB-I2C-ADPTZ and USB-I2C5W-ADPTZ—Adapter Boards

10684-007

## ORDERING INFORMATION

### BILL OF MATERIALS

Table 3. USB-SDP-CABLEZ

Qty.	Reference Designator	Description
2	C1, C2	Capacitor, 27 pF, 0402
6	C3, C4, C5, C6, C7, C8	Capacitor, 10 nF, 0402
20	C9, C10, C11, C12, C13, C14, C15, C16, C17, C18, C19, C20, C21, C22, C23, C30, C30, C31, C32, C33	Capacitor, 100 nF, 0402
2	D1, D2	ESD/TVD protection diode, 0603
1	J2	USB Mini-B connector
1	J3	10-way Micro-MaTch SMD socket
3	L1, L2, L3	Ferrite bead, 600 $\Omega$ at 100 MHz, 0603
1	LED1	Yellow LED, 0603
1	LED2	Red LED, 0603
1	LED3	Green LED, 0603
2	LK5, LK6	Solder links, not fitted
3	R1, R2, R3	Resistor, 10 k $\Omega$ , 0402
5	R4, R5, R6, R7, R8	Resistor, 2.2 k $\Omega$ , 0402
1	R9	Resistor, 12 k $\Omega$ , 0402
3	R10, R11, R12	Resistor 680 $\Omega$ , 0402
3	R13, R14, R15	Resistor, 100 $\Omega$ , 0603
1	R16	Resistor, 0 $\Omega$ , 0402
1	R22	Resistor, 100 k $\Omega$ , 0402
1	U1	USB serial converter, FTDI FT2232H, QFN-64
1	U2	SPI EEPROM, Microchip 93AA56BT-I, SOT23-6
1	U3	Supervisory circuit with watchdog and manual reset, Analog Devices ADM6384YKS29D1Z-R7, 4-lead SC70
1	U4	3.3 V linear regulator, Analog Devices ADP121, 5-lead TSOT
1	U9	2-input exclusive OR gate, TI SN74LVC1G86DBV, SOT23-5
1	U10	Open-drain buffer, Fairchild NC7WZ07P6X, SC70-6
1	U11	I <sup>2</sup> C bus buffer, NXP P82B96, SO8NB
1	U12	Low capacitance ESD protection, ST USBLC6-2P6, SOT666
1	Y1	Crystal, 12 MHz, NDK NX3225SA-12.000000 MHz

Table 4. USB-I2C-ADPTZ and USB-I2C5W-ADPTZ

Qty.	Reference Designator	Description
1	J1	10-way Micro-MaTch socket
1	J2	2 $\times$ 5-way 0.1" pitch header, not fitted
1	J3	3-way/5-way right angle 0.1" pitch female header

I<sup>2</sup>C refers to a communications protocol originally developed by Philips Semiconductors (now NXP Semiconductors).



#### ESD Caution

**ESD (electrostatic discharge) sensitive device.** Charged devices and circuit boards can discharge without detection. Although this product features patented or proprietary protection circuitry, damage may occur on devices subjected to high energy ESD. Therefore, proper ESD precautions should be taken to avoid performance degradation or loss of functionality.

#### Legal Terms and Conditions

By using the evaluation board discussed herein (together with any tools, components documentation or support materials, the "Evaluation Board"), you are agreeing to be bound by the terms and conditions set forth below ("Agreement") unless you have purchased the Evaluation Board, in which case the Analog Devices Standard Terms and Conditions of Sale shall govern. Do not use the Evaluation Board until you have read and agreed to the Agreement. Your use of the Evaluation Board shall signify your acceptance of the Agreement. This Agreement is made by and between you ("Customer") and Analog Devices, Inc. ("ADI"), with its principal place of business at One Technology Way, Norwood, MA 02062, USA. Subject to the terms and conditions of the Agreement, ADI hereby grants to Customer a free, limited, personal, temporary, non-exclusive, non-sublicensable, non-transferable license to use the Evaluation Board FOR EVALUATION PURPOSES ONLY. Customer understands and agrees that the Evaluation Board is provided for the sole and exclusive purpose referenced above, and agrees not to use the Evaluation Board for any other purpose. Furthermore, the license granted is expressly made subject to the following additional limitations: Customer shall not (i) rent, lease, display, sell, transfer, assign, sublicense, or distribute the Evaluation Board; and (ii) permit any Third Party to access the Evaluation Board. As used herein, the term "Third Party" includes any entity other than ADI, Customer, their employees, affiliates and in-house consultants. The Evaluation Board is NOT sold to Customer; all rights not expressly granted herein, including ownership of the Evaluation Board, are reserved by ADI. CONFIDENTIALITY. This Agreement and the Evaluation Board shall all be considered the confidential and proprietary information of ADI. Customer may not disclose or transfer any portion of the Evaluation Board to any other party for any reason. Upon discontinuation of use of the Evaluation Board or termination of this Agreement, Customer agrees to promptly return the Evaluation Board to ADI. ADDITIONAL RESTRICTIONS. Customer may not disassemble, decompile or reverse engineer chips on the Evaluation Board. Customer shall inform ADI of any occurred damages or any modifications or alterations it makes to the Evaluation Board, including but not limited to soldering or any other activity that affects the material content of the Evaluation Board. Modifications to the Evaluation Board must comply with applicable law, including but not limited to the RoHS Directive. TERMINATION. ADI may terminate this Agreement at any time upon giving written notice to Customer. Customer agrees to return to ADI the Evaluation Board at that time. LIMITATION OF LIABILITY. THE EVALUATION BOARD PROVIDED HEREUNDER IS PROVIDED "AS IS" AND ADI MAKES NO WARRANTIES OR REPRESENTATIONS OF ANY KIND WITH RESPECT TO IT. ADI SPECIFICALLY DISCLAIMS ANY REPRESENTATIONS, ENDORSEMENTS, GUARANTEES, OR WARRANTIES, EXPRESS OR IMPLIED, RELATED TO THE EVALUATION BOARD INCLUDING, BUT NOT LIMITED TO, THE IMPLIED WARRANTY OF MERCHANTABILITY, TITLE, FITNESS FOR A PARTICULAR PURPOSE OR NONINFRINGEMENT OF INTELLECTUAL PROPERTY RIGHTS. IN NO EVENT WILL ADI AND ITS LICENSORS BE LIABLE FOR ANY INCIDENTAL, SPECIAL, INDIRECT, OR CONSEQUENTIAL DAMAGES RESULTING FROM CUSTOMER'S POSSESSION OR USE OF THE EVALUATION BOARD, INCLUDING BUT NOT LIMITED TO LOST PROFITS, DELAY COSTS, LABOR COSTS OR LOSS OF GOODWILL. ADI'S TOTAL LIABILITY FROM ANY AND ALL CAUSES SHALL BE LIMITED TO THE AMOUNT OF ONE HUNDRED US DOLLARS (\$100.00). EXPORT. Customer agrees that it will not directly or indirectly export the Evaluation Board to another country, and that it will comply with all applicable United States federal laws and regulations relating to exports. GOVERNING LAW. This Agreement shall be governed by and construed in accordance with the substantive laws of the Commonwealth of Massachusetts (excluding conflict of law rules). Any legal action regarding this Agreement will be heard in the state or federal courts having jurisdiction in Suffolk County, Massachusetts, and Customer hereby submits to the personal jurisdiction and venue of such courts. The United Nations Convention on Contracts for the International Sale of Goods shall not apply to this Agreement and is expressly disclaimed.



Компания «ЭлектроПласт» предлагает заключение долгосрочных отношений при поставках импортных электронных компонентов на взаимовыгодных условиях!

Наши преимущества:

- Оперативные поставки широкого спектра электронных компонентов отечественного и импортного производства напрямую от производителей и с крупнейших мировых складов;
- Поставка более 17-ти миллионов наименований электронных компонентов;
- Поставка сложных, дефицитных, либо снятых с производства позиций;
- Оперативные сроки поставки под заказ (от 5 рабочих дней);
- Экспресс доставка в любую точку России;
- Техническая поддержка проекта, помощь в подборе аналогов, поставка прототипов;
- Система менеджмента качества сертифицирована по Международному стандарту ISO 9001;
- Лицензия ФСБ на осуществление работ с использованием сведений, составляющих государственную тайну;
- Поставка специализированных компонентов (Xilinx, Altera, Analog Devices, Intersil, Interpoint, Microsemi, Aeroflex, Peregrine, Syfer, Eurofarad, Texas Instrument, Miteq, Cobham, E2V, MA-COM, Hittite, Mini-Circuits, General Dynamics и др.);

Помимо этого, одним из направлений компании «ЭлектроПласт» является направление «Источники питания». Мы предлагаем Вам помощь Конструкторского отдела:

- Подбор оптимального решения, техническое обоснование при выборе компонента;
- Подбор аналогов;
- Консультации по применению компонента;
- Поставка образцов и прототипов;
- Техническая поддержка проекта;
- Защита от снятия компонента с производства.



#### Как с нами связаться

**Телефон:** 8 (812) 309 58 32 (многоканальный)

**Факс:** 8 (812) 320-02-42

**Электронная почта:** [org@eplast1.ru](mailto:org@eplast1.ru)

**Адрес:** 198099, г. Санкт-Петербург, ул. Калинина, дом 2, корпус 4, литера А.