



ABAC

MIL-DTL-38999 Series III



Belief in Technology

Contents



03	Company Profile
04	About TT Electronics
06	Technical Information
08	Part number explanations
09	Orientation
10	Insert Arrangements
11	Insert Arrangement Specification
14	Receptacle Type 20 / Receptacle Type 24
15	Inline Receptacle Type 12 / Box Mounting Receptacle Type 13
16	Wall Mounting Receptacle with pcb stand-off Type 14
17	Jam Nut Receptacle with pcb stand-off Type 15
18	Bulkhead Connector Type 11 / Recommended Jam Nut Torque Values
19	Fixed Connector with PC Tails
20	MIL-DTL-38999 Plug Type 26 / MIL-DTL-38999 Integral Backshell Type 37
21	Mated Connector Dimensions / Panel Cut out Information
22	Straight backshell for band termination & heat shrink boot
23	Right angle backshell for band termination & heat shrink boot
24	Straight Screen Trap Adapter
25	90° Angled Screen Trap Adapter
26	Fixed Protective Caps
27	Free Protective Caps
28	Stowage Receptacle / Screened Gaskets
29	Contacts
30	Insertion & Extraction
31	Contact Insertion
32	Contact Extraction
33	Safety Information
34	TT Electronics and the Environment
35	Global Sales Offices

Company Profile

There are TT electronics products in every single military vehicle deployed in conflict zones across the globe.

TT electronics plc is an international electronics company that has been supplying innovative high reliability components to the military and defence markets for more than 30 years. The knowledge and experience gained in that time has been brought together in a global team of designers and applications engineers dedicated to supporting the unique requirements of modern military applications. Our industry experience and agile approach to business has given us a pre-eminent position in the supply of connectors and other components to land-based military vehicles.

As a major plc listed on the London stock exchange, TT electronics plc has the financial resources to continually invest in up-to-the-minute manufacturing facilities to address our customer's needs and provide them with the correct solution. With design and manufacturing plants in Europe and the USA, we are able to fulfil the Urgent Operational Requirements (UORs) of defence forces globally with industrial and mil spec compliant connectors and assemblies at exceptionally short notice.

In the harsh and unforgiving environment of the modern battlefield, it is essential that every single component is fit for purpose. Working closely on site with our OEM and ODM customers has given our engineering team a deep understanding of the changing market trends and requirements of land based military vehicles, enabling them to engineer the best possible component solution.



About TT electronics plc

TT electronics plc is a global electronics company. Within its electronic components group are multiple facilities for design and manufacture of interconnection systems with engineering teams providing custom solutions.

Military land based vehicles

- Tracked vehicle
- Armoured personnel carriers
- Land Rover
- Unmanned vehicles
- Security services

Electrical systems in the modern military vehicle need to provide the user with a ruggedised reliable solution to the interconnection issues encountered in a battlefield theatre environment. With high reliability being taken as a given we are in the position to offer solutions to brave the most demanding of applications.



Rotary wing aircraft

- Military helicopters
- Search and Rescue
- Commercial helicopters

Vibration and salt spray are just two of the hazards facing military aircraft. We have developed a range of screening products that allow the termination of multiple screens in just such environments without degradation to interconnection systems. Design and manufacture of complex cable harnesses form part of our core strengths. We are actively involved with all systems within helicopter operations including UOR activities system upgrades and role fits.



Military fixed wing aircraft

- Jet fighters
- Propeller technology
- Reconnaissance
- Mission control suites

The requirement for electrical protection on military platforms becomes even more critical as both the natural effects of lightning and the effect of warfare can play havoc with electrical systems in the air and on the ground.

We provide cost effective electrical interface systems designed to withstand the effects of EMC, EMI, EMP and HIRF along with the harshest of environmental conditions.



Missile and defensive suites

- Defensive aids suites
- Test equipment solutions
- Radar equipment interconnects

As the need grows for smaller systems we design lighter, more compact interconnection systems featuring miniaturisation of connector products and lightweight wiring solutions. Screening remains a high priority and a full range of connector accessories for all styles of connector form part of our portfolio to ensure design is not compromised in any way



Civil aircraft

- Landing gear
- Flight guidance systems
- Engine management

The civil aircraft market demands reliable manufacturing processes. We produce critical systems designed to ensure our solutions are in line with those requirements. Cost efficient, light-weight reliable solutions are an integral part of any design specification.

We have a market leading technology in composite systems, enabling your designers to enhance your product offering to your customer.



Naval systems

- Radar systems
- Submarine communications
- Panel assemblies

The issues facing naval applications bring a whole new set of problems to the design of interconnection systems. We offer screened cable and conduit systems approved for "above deck full threat EMP protection". The ability to manufacture interconnection panels and a component product range offering salt spray protection, ensures environmental issues are catered for during the design process



ABAC

technical information

Materials

Shell:	Aluminium
Insulator:	Rigid plastic / silicone rubber
Contacts:	Copper alloy



Standard Plating Finishes

Aluminium parts:	Cadmium Olive drab (W) Electroless Nickel (F) Nickel Fluorocarbon Polymer (T) Zinc cobalt green passivate (Q) Black Zinc cobalt (QB)
Contacts:	Gold over nickel plated

* Consult factory for alternative finishes.

Environmental Ratings

Temperature range:	-65°C to + 175°C
Shock:	300g, 3 ms according EN 2591-D2 method A
Vibration:	Sine: 10 to 2000 Hz, 3x12 hrs (60g, 140-2000 Hz) with temperature cycling Random: 50 to 2000 Hz, 2x8 hrs (1g ² / Hz, 100-2000Hz) at T ^o max. 25 to 2000 Hz, 2x8 hrs (5g ² / Hz, 100-300Hz) (at ambient T ^o) Test with accessories in acc. with EN 2591-D3
Sealing:	Mated connectors meet altitude immersion requirements of MIL-DTL-38999
Salt spray:	500 hrs
Resistance to fluids:	Gasoline: JP5 (OTAN F44) Mineral hydraulic fluid: MIL-H-5606 (OTAN H515) Synthetic hydraulic fluid: Skydrol 500 B4 Mineral lubricating: MIL-L-7870A (OTAN 0142) Synthetic lubricating: MIL-L-23699 (OTAN 0156), MIL-L7808 Cleaning fluid: MIL-DTL-25769 diluted De-icing fluid: MIL-A-8243 Extinguishing fluid: Chlorobrométhane Cooling fluid: Coolanol

Mechanical Features

Coupling:	3 start stub acme thread
Contact termination:	Crimp
Sealing:	Dynamic sealing ring & individual wire seal grommet. IP67 rated.
Endurance:	500 mating / unmating operations

Note: The company reserves the right and may change or vary specification without prior written notice.

ABAC

technical information

Test Voltage Rating (Vrms)

Test Voltage, ac rms, 60 Hz

Altitude	Service rating M		Service rating N		Service rating I		Service rating II	
	mated	unmated	mated	unmated	mated	unmated	mated	unmated
Sea Level	1300	1300	1000	1000	1800	1800	2300	2300
50,000 ft.	800	550	600	400	1000	600	1000	800
70,000 ft.	800	350	600	260	1000	400	1000	500
100,000 ft.	800	200	600	200	1000	200	1000	200

Insulation Resistance

≥ 5 000 MΩ (at 500 Vdc) - at ambient

Max. Current Rating

≥ 5 000 MΩ (at 500 Vdc)

Cts Size	22	20	16	12	Power
Contact Rating (A)	5	7,5	13	23	45

Shell continuity: 2.5 mΩ
 Shielding: 90 db at 100 MHz - 50 db at 10 GHz

ABAC

part number explanations

AB Part Number Explanation

Product Range:	AB AC	20	W	11	35	P	N	XX
Shell style:	16 : Square flange receptacle with clinch nuts 20 : Square flange receptacle 24 : Jam nut receptacle 26 : Plug with RFI shielding 12 : Inline cable receptacle 13 : Box Mounting receptacle 14 : Square flange receptacle with PCB stand off 15 : Jam nut receptacle with PCB stand off 37 : Cable Plug with RFI and integral backshell							
Plating:	W : Olive drab cadmium -65 °C to 175 °C F : Electroless Nickel -65 °C to 200 °C T : Nickel Fluorocarbon Polymer -65 °C to 175 °C Q : Zinc cobalt green passivate -65 °C to 175 °C QB : Black Zinc cobalt -65 °C to 175 °C							
Shell size:	9, 11, 13, 15, 17, 19, 21, 23 or 25							
Contact layout:	See pages 10, 11 & 12							
Contact type:	P : Pin		A : Pin insert without contacts					
	S : Socket		B : Socket insert without contacts					
Orientation:	N, A, B, C, D & E (See page 9)							
Modification:	Please consult factory							

MIL-DTL-38999 Part Number Explanation

Basic Series:	D38999	20	W	B	35	P	N
Shell style:	20 : Square flange receptacle 24 : Jam nut receptacle 26 : Plug with RFI shielding						
Plating:	W : Olive drab cadmium -65 °C to 175 °C						
Shell size:	A - B - C - D - E - F - G - H - J						
Contact layout:	See pages 10, 11 & 12						
Contact type:	P : Pin		A : Pin insert without contacts				
	S : Socket		B : Socket insert without contacts				
Orientation:	N, A, B, C, D & E (See page 9)						

ABAC orientation

Viewed from face of receptacle



Viewed from front of plug



Shell Size	MS Shell Size	Angles	N	A	B	C	D	E
9	A	A°	105	102	80	35	64	91
		B°	140	132	118	140	155	131
		C°	215	248	230	205	234	197
		D°	265	320	312	275	304	240
11	B	A°	95	113	90	53	119	51
		B°	141	156	145	156	146	141
		C°	208	182	195	220	176	184
		D°	236	292	252	255	298	242
13	C	A°	95	113	90	53	119	51
		B°	141	156	145	156	146	141
		C°	208	182	195	220	176	184
		D°	236	292	252	255	298	242
15	D	A°	95	113	90	53	119	51
		B°	141	156	145	156	146	41
		C°	208	182	195	220	176	184
		D°	236	292	252	255	298	242
17	E	A°	80	135	49	66	62	79
		B°	142	170	169	140	145	153
		C°	196	200	200	200	180	197
		D°	293	310	244	257	280	272
19	F	A°	80	135	49	66	62	79
		B°	142	170	169	140	145	153
		C°	196	200	200	200	180	197
		D°	293	310	244	257	280	272
21	G	A°	80	135	49	66	62	79
		B°	142	170	169	140	145	153
		C°	196	200	200	200	180	197
		D°	293	310	244	257	280	272
23	H	A°	80	135	49	66	62	79
		B°	142	170	169	140	145	153
		C°	196	200	200	200	180	197
		D°	293	310	244	257	280	272
25	J	A°	80	135	49	66	62	79
		B°	142	170	169	140	145	153
		C°	196	200	200	200	180	197
		D°	293	310	244	257	280	272

ABAC

insert arrangements

	Size 22D Contact
	Size 20 Contact
	Size 16 Contact
	Size 12 Contact
	Twinax Contact, Size 8



Shell Size 9

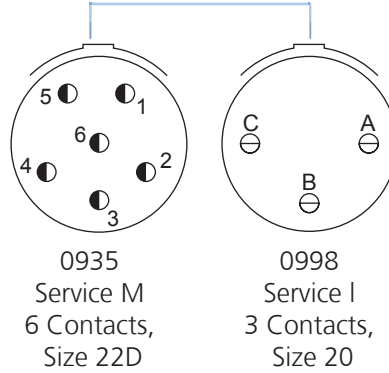

Shell Size 11

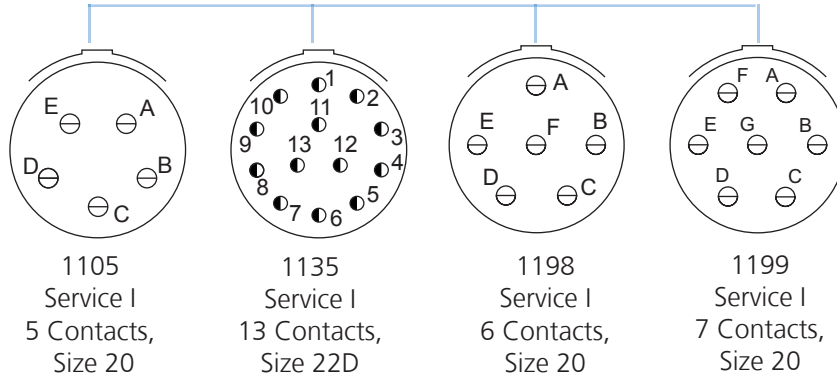

Shell Size 13

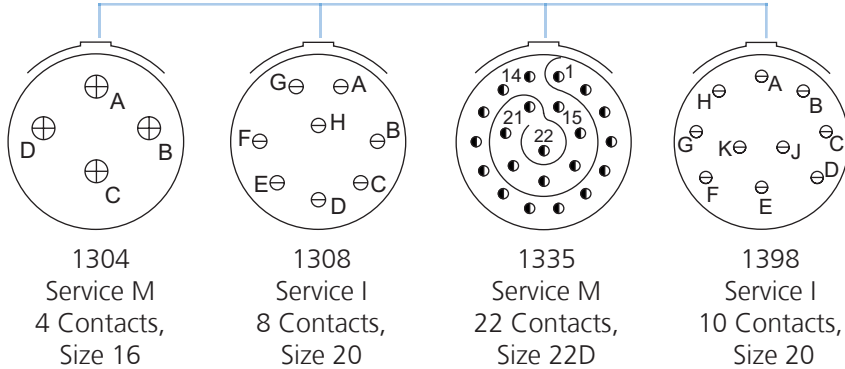

Shell Size 15

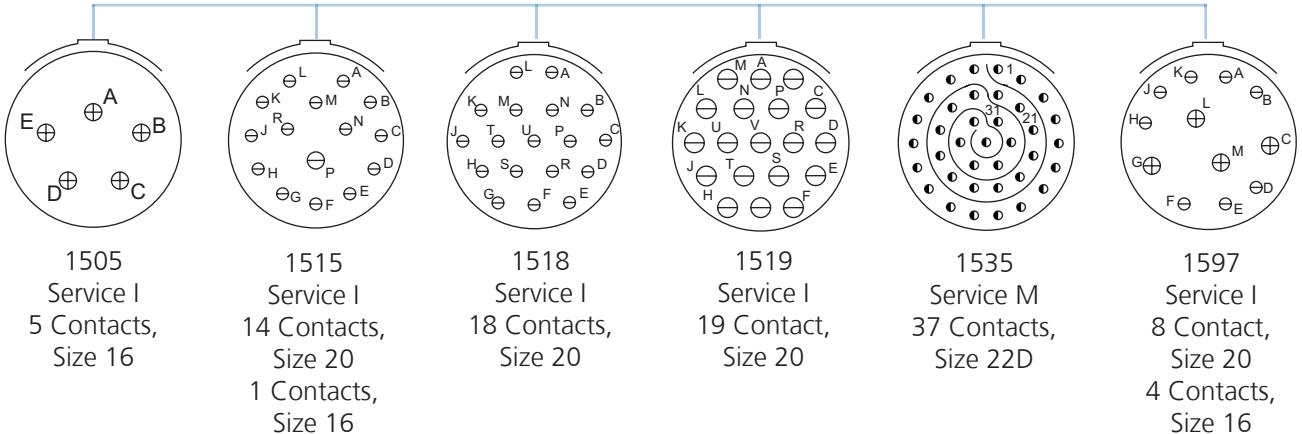

Shell Size 17



Shell Size 19



Shell Size 21



Shell Size 23



Note: Consult factory for other insert arrangements

ABAC

insert arrangements
continued...

Shell Size 25



2520
Service N
10 Contacts, Size 20
13 Contacts, Size 16
4 Coax Contacts,
Size 12
3 Twinax Contacts,
Size 8



2524
Service I
12 Contacts,
Size 12
12 Contacts,
Size 16



2535
Service M
128 Contacts,
Size 22D

Shell Size 25



2546
Service I
40 Contacts, Size 20
4 Contacts, Size 16
2 Coax Contacts,
Size 8



ABAC

insert arrangement specification

Shell Size	MS Shell Size	Contact Arrangement	No. of Contacts	Size 22D	Size 20	Size 16	Size 12	Size 8 Twinax
9	A	09-35	6	6				
		09-98	3		3			
11	B	11-05	5		5			
		11-35	13	13				
		11-98	6		6			
		11-99	7		7			
13	C	13-04	4			4		
		13-08	8		8			
		13-35	22	22				
		13-98	10		10			
15	D	15-05	5			5		
		15-15	15		14	1		
		15-18	18		18			
		15-19	19		19			
		15-35	37	37				
		15-97	12		8	4		
17	E	17-06	6				6	
		17-08	8			8		
		17-26	26		26			
		17-35	55	55				
		17-99	23		21	2		
19	F	19-11	11			11		
		19-28	28		26	2		
		19-32	32		32			
		19-35	66	66				
21	G	21-11	11				11	
		21-16	16			16		
		21-35	79	79				
		21-41	41		41			
		21-75	4					4
23	H	23-21	21			21		
		23-32	32		32			
		23-35	100	100				
		23-55	55		55			
25	I	25-20	30		10	13	4 (coax)	3
		25-24	24			12	12	
		25-35	128	128				
		25-46	46		40	4		2

ABAC

MIL-DTL-38999 receptacle type 20

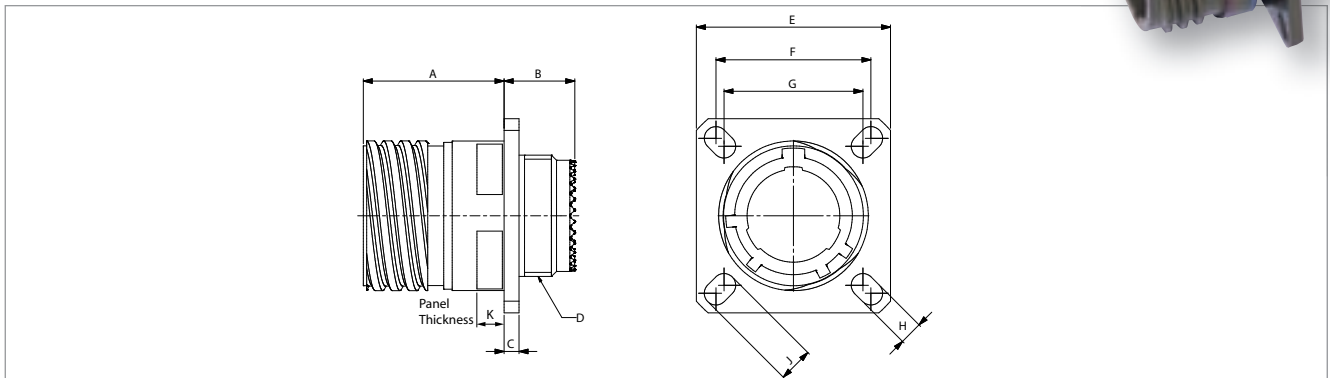
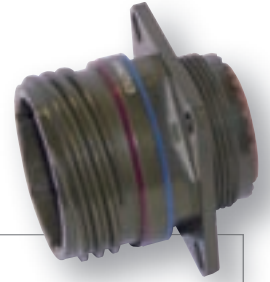

Shell Size	A max.	B max.	C max.	D thread	E ± 0.30	F	G	H ± 0.20	J ± 0.20	K max.
09	20.90	10.60	2.50	M12 x 1-6g	23.80	18.26	15.09	3.25	5.49	5.94
11	20.90	10.60	2.50	M15 x 1-6g	26.20	20.62	18.26	3.25	4.93	5.94
13	20.90	10.60	2.50	M18 x 1-6g	28.60	23.01	20.62	3.25	4.93	5.94
15	20.90	10.60	2.50	M22 x 1-6g	31.00	24.61	23.01	3.25	4.93	5.94
17	20.90	10.60	2.50	M25 x 1-6g	33.30	26.97	24.61	3.25	4.93	5.94
19	20.90	10.60	2.50	M28 x 1-6g	36.50	29.36	26.97	3.25	4.93	5.94
21	20.10	11.40	3.20	M31 x 1-6g	39.70	31.75	29.36	3.25	4.93	5.18
23	20.10	11.40	3.20	M34 x 1-6g	42.90	34.93	31.75	3.91	6.15	5.18
25	20.10	11.40	3.20	M37 x 1-6g	46.00	38.10	34.93	3.91	6.15	5.18

ABAC

MIL-DTL-38999 receptacle type 24

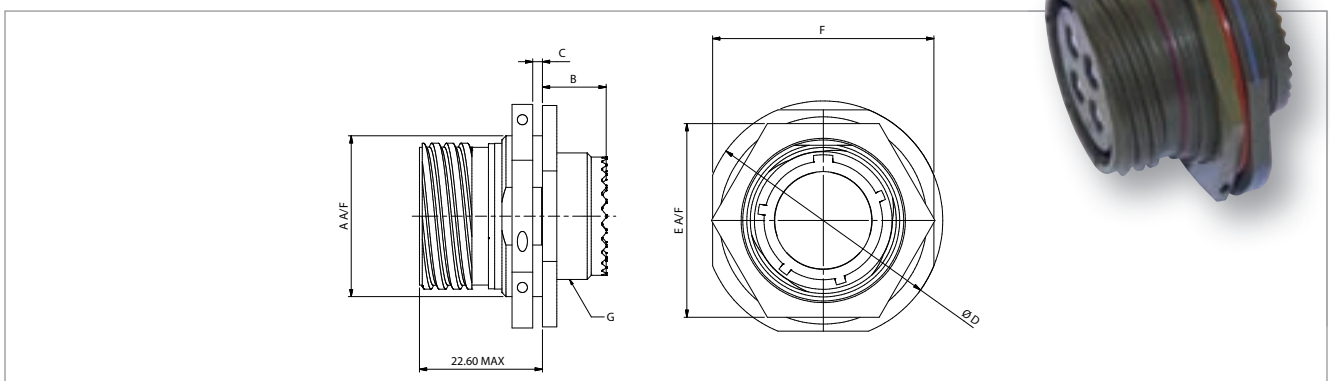
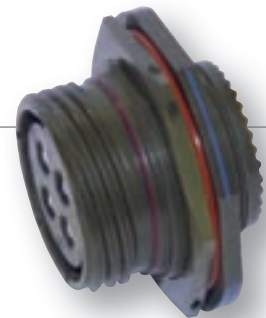

Shell Size	A + 0.10 - 0.15	B max.	C max.	D Ø max.	E max.	F ± 0.40	G thread
09	16.53	9.90	3.20	30.50	23.00	27.00	M12 x 1-6g
11	19.07	9.90	3.20	35.20	26.00	31.80	M15 x 1-6g
13	23.82	9.90	3.20	38.40	31.00	34.90	M18 x 1-6g
15	26.97	9.90	3.20	41.60	34.00	38.10	M22 x 1-6g
17	30.15	9.90	3.20	44.80	37.00	41.30	M25 x 1-6g
19	33.32	9.90	3.50	49.50	41.00	46.00	M28 x 1-6g
21	36.50	9.90	3.50	52.70	46.00	49.20	M31 x 1-6g
23	39.67	9.90	3.50	55.90	47.00	52.40	M34 x 1-6g
25	42.85	9.90	3.50	59.00	52.00	55.60	M37 x 1-6g

ABAC

in line receptacle type 12

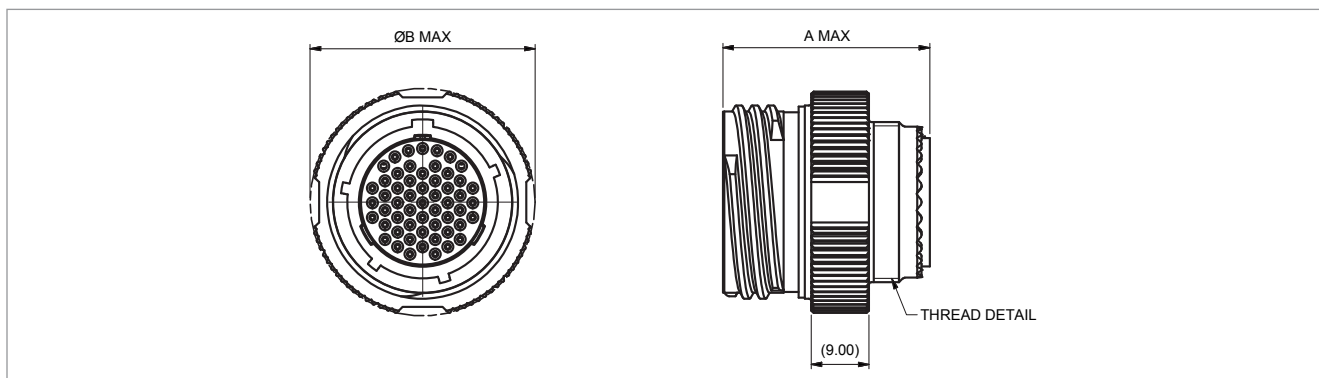

Shell Size	A Max	ØD Max	Thread Detail
9	33	21	M12x1-6g
11	33	23.7	M15x1-6g
13	33	29.3	M18x1-6g
15	33	31.3	M22x1-6g
17	33	35.67	M25x1-6g
19	33	38.4	M28x1-6g
21	33	41.67	M31x1-6g
23	33	44.9	M34x1-6g
25	33	47.97	M37x1-6g

ABAC

box mounting receptacle type 13

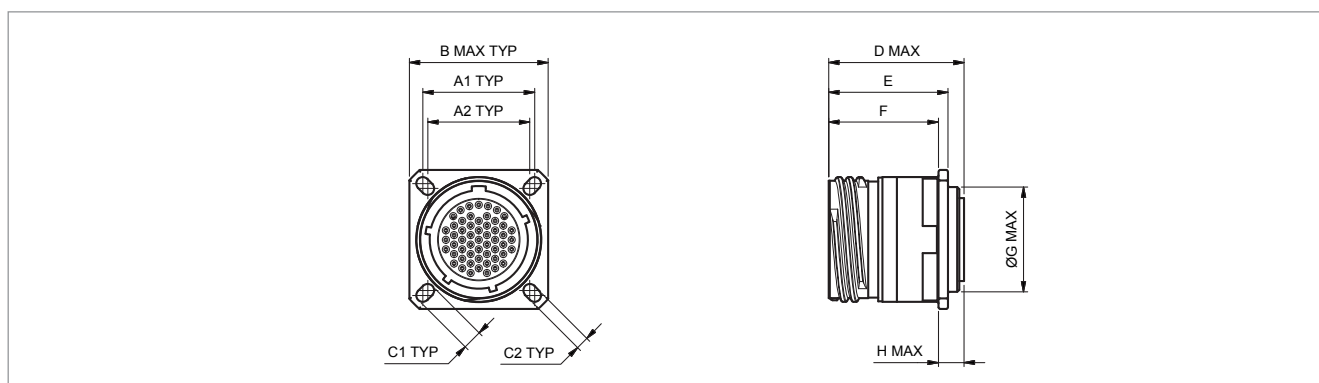

Shell Size	A1	A2	D Max	E	F	ØG Max	H Max	B Max	C1 ±0.20	C2 ±0.20
9	18.26	15.09	33.00	28.59 - 28.79	26.29 - 26.49	12.71	6.50	24.00	5.49	3.25
11	20.62	18.26	33.00	28.59 - 28.79	26.29 - 26.49	15.48	6.50	26.40	4.93	3.25
13	23.01	20.62	33.00	28.59 - 28.79	26.29 - 26.49	18.65	6.50	28.80	4.93	3.25
15	24.61	23.01	33.00	28.59 - 28.79	26.29 - 26.49	22.61	6.50	31.20	4.93	3.25
17	26.97	24.61	33.00	28.59 - 28.79	26.29 - 26.49	25.41	6.50	33.50	4.93	3.25
19	29.36	26.97	33.00	28.59 - 28.79	26.29 - 26.49	28.58	6.50	36.70	4.93	3.25
21	31.75	29.36	33.00	29.29 - 29.49	26.29 - 26.49	31.76	6.50	39.90	4.93	3.25
23	34.93	31.75	33.00	29.29 - 29.49	26.29 - 26.49	34.53	6.50	43.10	6.15	3.91
25	38.10	34.93	33.00	29.29 - 29.49	26.29 - 26.49	37.29	6.50	46.20	6.15	3.91

ABAC

wall mounting receptacle with pcb stand-off type 14 (sizes 9 & 11)

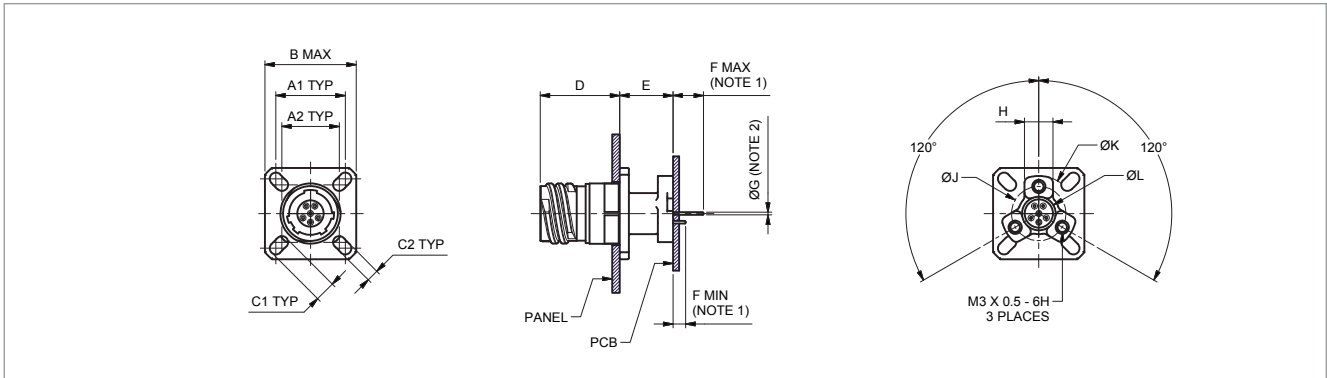

Shell Size	A1	A2	B Max	C1	C2	D	E	F Min	F Max	H	ØJ	ØK	ØL
9	18.26	15.09	24.1	5.29 - 5.69	3.05 - 3.45	20.80 - 20.90	13.90 - 14.00	2.41	7.86	7.36 - 7.46	14.3	19.70 - 19.80	8.8
11	20.62	18.26	26.5	4.73 - 5.13	3.05 - 3.45	20.80 - 20.90	13.90 - 14.00	2.41	7.86	7.36 - 7.46	18.1	23.50 - 23.60	12.6

ABAC

wall mounting receptacle with pcb stand-off type 14 (sizes 13 - 25)

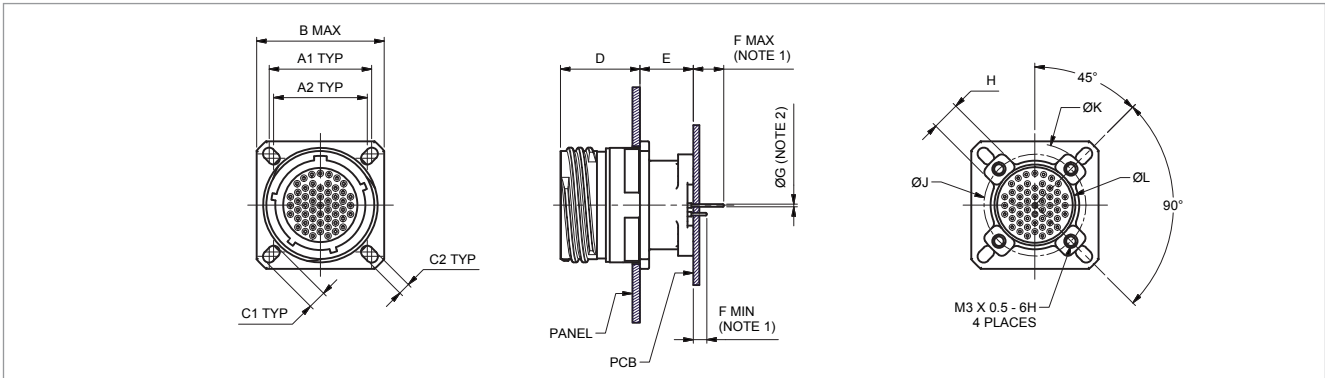

Shell Size	A1	A2	B Max	C1	C2	D	E	F Min	F Max	H	ØJ	ØK	ØL
13	23.01	20.62	28.9	4.73 - 5.13	3.05 - 3.45	20.80 - 20.90	13.90 - 14.00	2.41	7.86	7.36 - 7.46	20.46	25.86 - 25.96	14.96
15	24.61	23.01	31.3	4.73 - 5.13	3.05 - 3.45	20.80 - 20.90	13.90 - 14.00	2.41	7.86	7.36 - 7.46	23.52	28.92 - 29.02	18.02
17	26.97	24.61	33.6	4.73 - 5.13	3.05 - 3.45	20.80 - 20.90	13.90 - 14.00	2.41	7.86	7.36 - 7.46	26.81	32.20 - 32.30	21.3
19	29.39	26.97	36.8	4.73 - 5.13	3.05 - 3.45	20.80 - 20.90	13.90 - 14.00	2.41	7.86	7.36 - 7.46	29.36	34.76 - 34.86	23.86
21	31.75	29.39	40	4.73 - 5.13	3.05 - 3.45	20.00 - 20.10	14.70 - 14.80	2.41	7.86	7.36 - 7.46	32.67	38.07 - 38.17	27.17
23	34.93	31.75	43.2	5.95 - 6.35	3.71 - 4.11	20.00 - 20.10	14.70 - 14.80	2.41	7.86	7.36 - 7.46	36.05	41.45 - 41.55	30.55
25	38.1	34.93	46.3	5.95 - 6.35	3.71 - 4.11	20.00 - 20.10	14.70 - 14.80	2.41	7.86	7.36 - 7.46	39.02	44.42 - 44.52	33.52

ABAC

jam nut mounting receptacle with pcb stand-off type 15 (sizes 9 & 11)

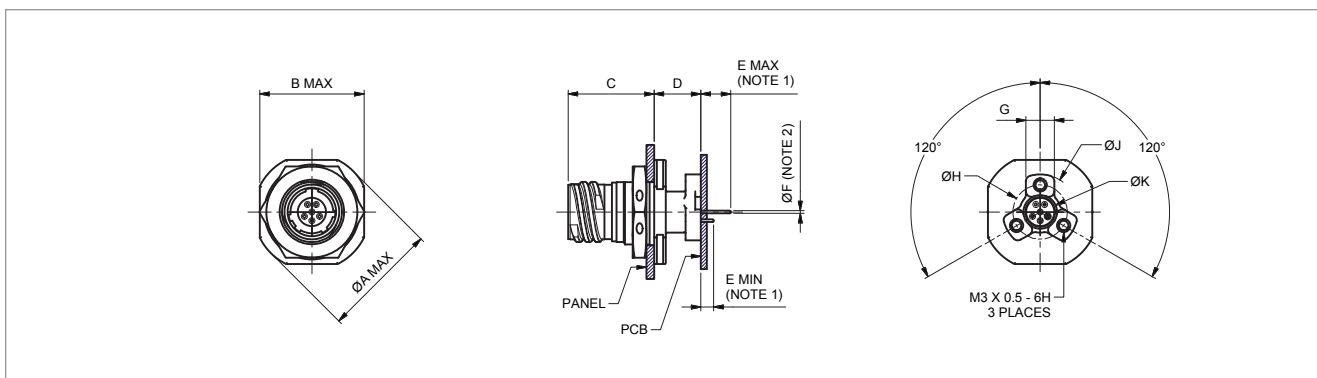

Shell Size	ØA Max	B Max	C	D	E Min	E Max	G	ØH	ØJ	ØK
9	30.50	27.40	22.50 - 22.60	12.20 - 12.30	2.41	7.86	7.36 - 7.46	14.3	19.70 - 19.80	8.8
11	35.20	32.20	22.50 - 22.60	12.20 - 12.30	2.41	7.86	7.36 - 7.46	18.1	23.50 - 23.60	12.6

ABAC

jam nut mounting receptacle with pcb stand-off type 15 (sizes 13 - 25)

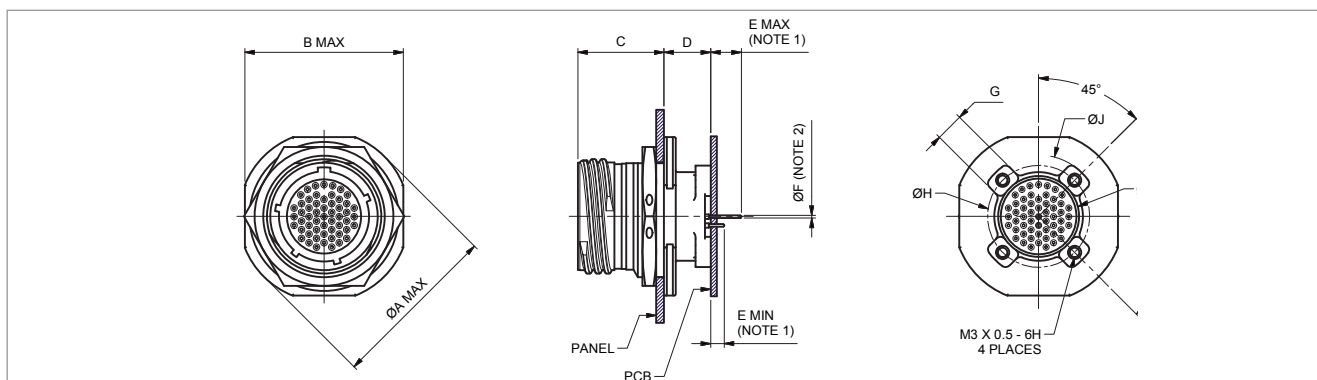

Shell Size	ØA Max	B Max	C	D	E Min	E Max	G	ØH	ØJ	ØK
13	38.40	35.30	22.50 - 22.60	12.20 - 12.30	2.41	7.86	7.36 - 7.46	20.46	25.86 - 25.96	14.96
15	41.60	38.50	22.50 - 22.60	12.20 - 12.30	2.41	7.86	7.36 - 7.46	23.52	28.92 - 29.02	18.02
17	44.80	41.70	22.50 - 22.60	12.20 - 12.30	2.41	7.86	7.36 - 7.46	26.81	32.20 - 32.30	21.3
19	49.50	46.40	22.50 - 22.60	12.20 - 12.30	2.41	7.86	7.36 - 7.46	29.36	34.76 - 34.86	23.86
21	52.70	49.60	22.50 - 22.60	12.20 - 12.30	2.41	7.86	7.36 - 7.46	32.67	38.07 - 38.17	27.17
23	55.90	52.80	22.50 - 22.60	12.20 - 12.30	2.41	7.86	7.36 - 7.46	36.05	41.45 - 41.55	30.55
25	59.00	56.00	22.50 - 22.60	12.20 - 12.30	2.41	7.86	7.36 - 7.46	39.02	44.42 - 44.52	33.5

ABAC

bulkhead connector type 11

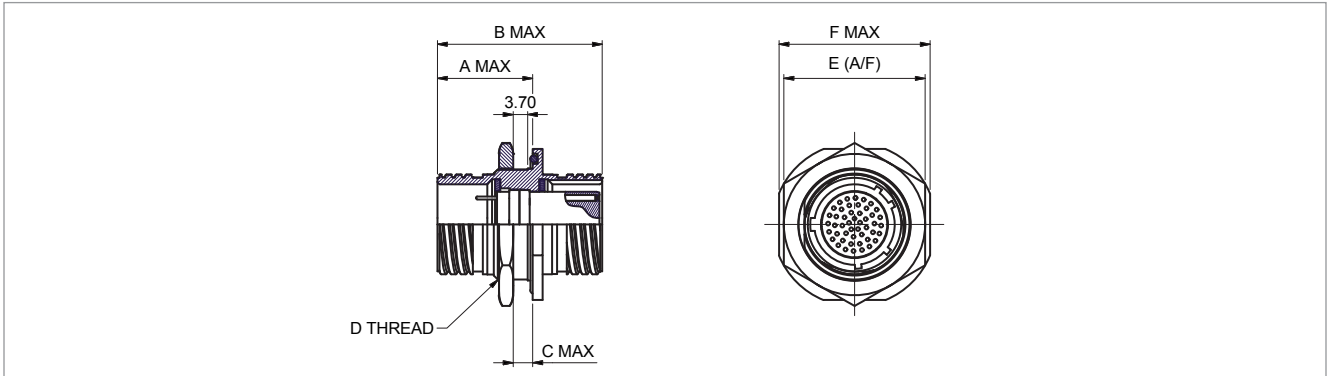

Shell Size	A max	B max	C max	D Thread	E (A/F)	F max
9	25.50	42.10	6.40	M17 x 1.0	24.00	27.40
11	25.50	42.10	6.40	M20 x 1.0	27.00	32.20
13	25.50	42.10	6.40	M25 x 1.0	32.00	35.30
15	25.50	42.10	6.40	M28 x 1.0	36.00	38.50
17	25.50	42.10	6.40	M32 x 1.0	37.00	41.70
19	25.50	42.10	6.40	M35 x 1.0	41.00	46.40
21	25.50	42.10	6.40	M38 x 1.0	46.00	49.60
23	25.50	42.10	6.40	M41 x 1.0	50.00	52.80
25	25.50	42.10	6.40	M44 x 1.0	51.00	56.00

MIL-DTL-38999

recommended jam nut torque values

Shell Size	Inch-pounds
9	30/36
11	40/46
13	55/60
15	70/75
17	80/85
19	90/95
21	100/110
23	110/120
25	120/130

ABAC

fixed connector with pc tails

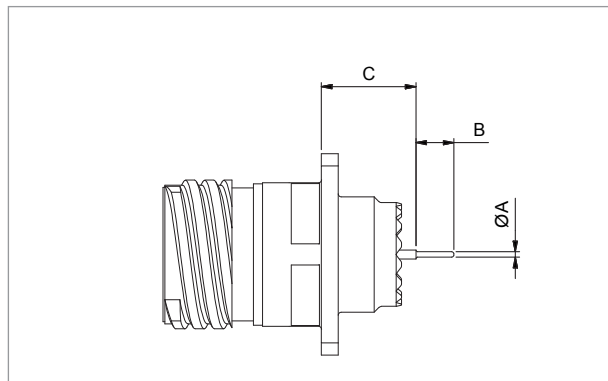
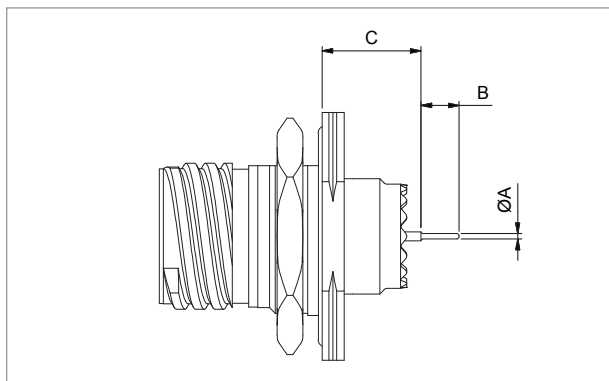

Type 24 Jam Nut Style		
Shell Size	C Min	C Max
9	12.21	13.36
11	12.21	13.36
13	12.32	13.34
15	12.32	13.34
17	12.21	13.36
19	12.01	13.16
21	13.01	14.16
23	13.01	14.16
25	13.03	14.16

Type 20 Square Flange Style		
Shell Size	C Min	C Max
9	10.49	11.63
11	10.49	11.63
13	10.49	11.63
15	10.49	11.63
17	10.49	11.63
19	10.49	11.63
21	10.49	11.63
23	10.49	11.63
25	10.51	11.63

Contacts			
Contact Size	Mod Code Ref.	ØA	B
22D	M03	0.70	8.50
22D	M09	0.70	4.00
22D	M10	0.50	5.10
20	M09	0.70	5.10
16	M09	1.15	5.10



ABAC

MIL-DTL-38999 plug type 26

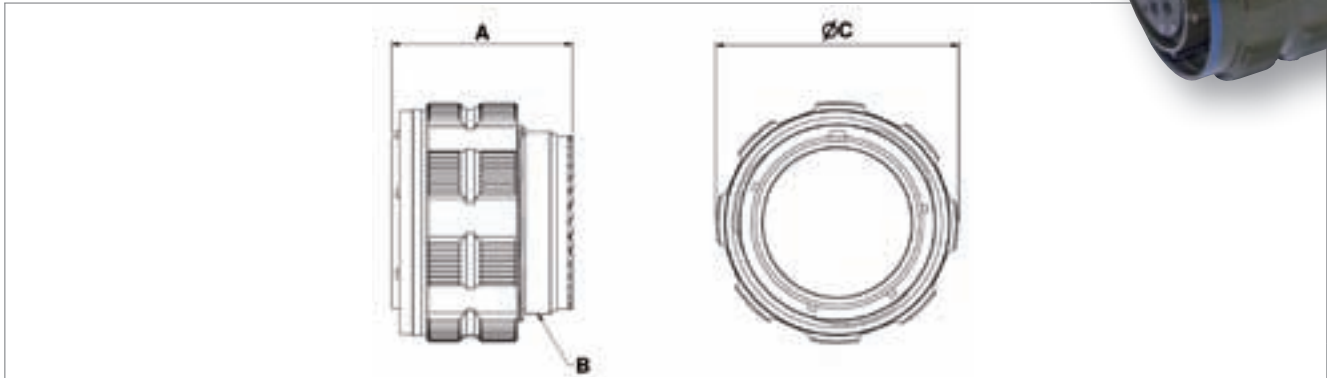

Shell Size	A Max	B Thread	C Max
09	31.00	M12 x 1-6g	21.80
11	31.00	M15 x 1-6g	25.00
13	31.00	M18 x 1-6g	29.40
15	31.00	M22 x 1-6g	32.50
17	31.00	M25 x 1-6g	35.70
19	31.00	M28 x 1-6g	38.50
21	31.00	M31 x 1-6g	41.70
23	31.00	M34 x 1-6g	44.90
25	31.00	M37 x 1-6g	48.00

ABAC

plug with integral backshell type 37

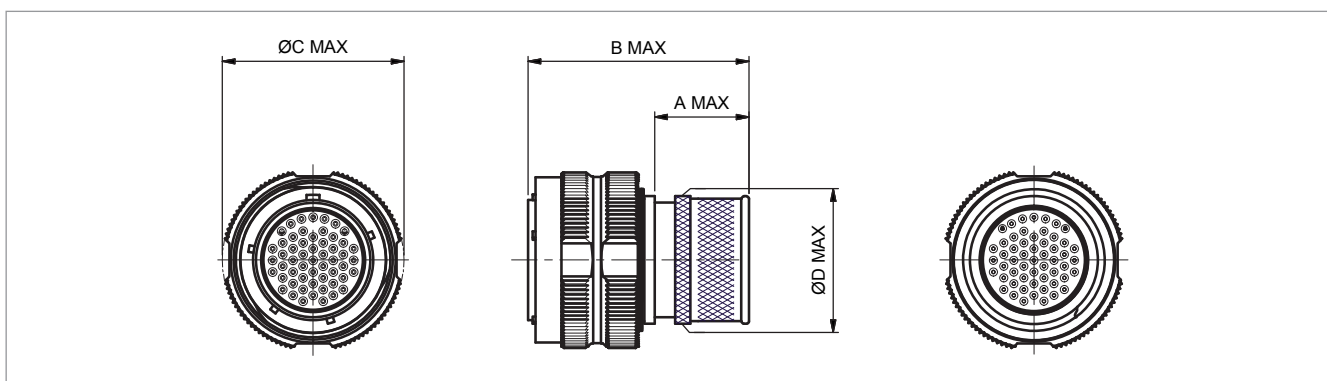

Shell Size	A Max	B Max	ØC Max	ØD Max
9	18.50	43.35	21.00	12.00
11	18.50	43.35	23.70	15.05
13	18.50	43.35	29.30	18.05
15	18.50	43.35	31.30	22.05
17	18.50	43.35	35.67	25.05
19	18.50	43.35	38.40	28.05
21	18.50	43.35	41.67	31.05
23	18.50	43.35	44.90	34.05
25	18.50	43.35	47.97	37.05

MIL-DTL-38999

mated connector dimensions

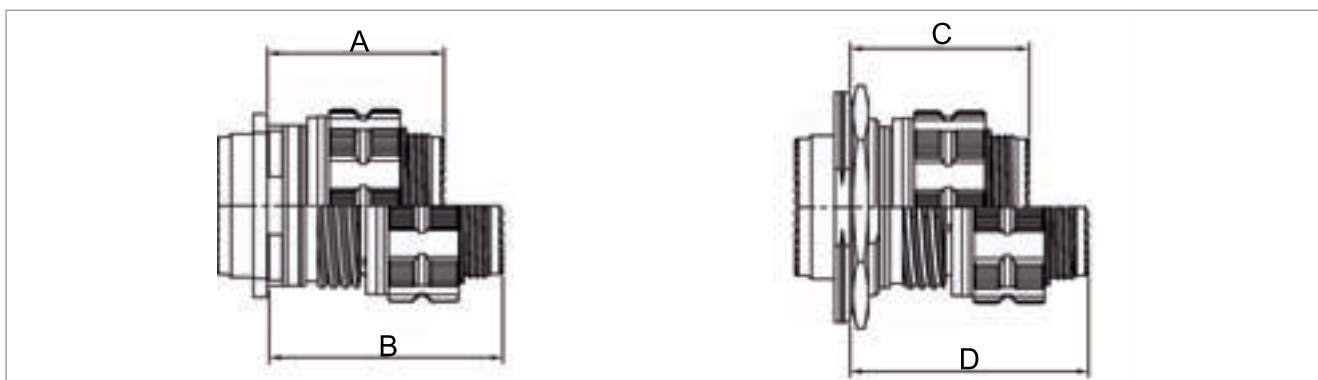

Shell Size	A max	B max	C max	D Max
09	37.00	52.30	38.30	53.60
11	37.00	52.30	38.30	53.60
13	37.00	52.30	38.50	53.80
15	37.00	52.30	38.50	53.80
17	37.00	52.30	38.50	53.80
19	37.00	52.30	38.50	53.80
21	36.00	51.30	38.50	53.80
23	36.00	51.30	38.50	53.80
25	36.00	51.30	38.50	53.80

MIL-DTL-38999

panel cut-out information

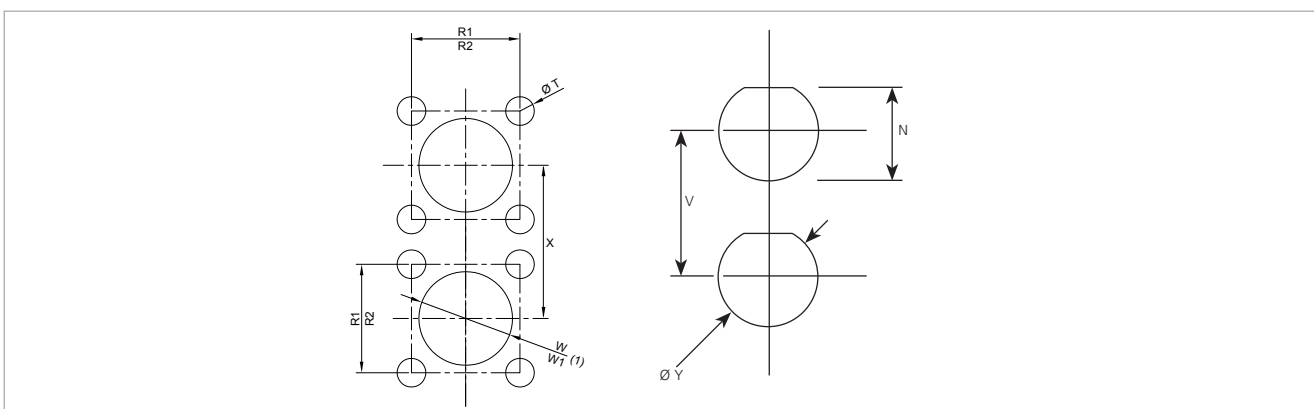

Shell Size	N -0.25	R1 Rear Mount	R2 Front Mount	T Ø +/- 0.13	V min.	W min. Rear Mount	W1 min. Front Mount	X min. + 0.25	Ø Y
09	16.74 -0.06	18.26	15.09	3.25	30.76	16.66	13.11	24.61	17.10
11	19.59	20.62	18.26	3.25	34.21	20.22	15.88	27.22	20.96
13	24.26	23.01	20.62	3.25	40.00	23.42	19.05	30.15	25.65
15	27.56	24.61	23.01	3.25	44.63	26.59	23.01	33.24	28.83
17	30.73	26.97	24.61	3.25	45.77	30.96	25.81	36.44	32.01
19	33.91	29.36	26.97	3.25	50.40	32.94	28.98	39.24	35.18
21	37.08	31.75	29.36	3.25	56.16	36.12	32.16	42.44	38.35
23	40.26	34.93	31.75	3.91	60.81	39.29	34.93	45.64	41.53
25	43.43	38.10	34.93	3.91	62.18	42.47	37.69	48.48	44.70

ABAC

straight backshell for band termination & heat shrink boot

Style: ABAC 01

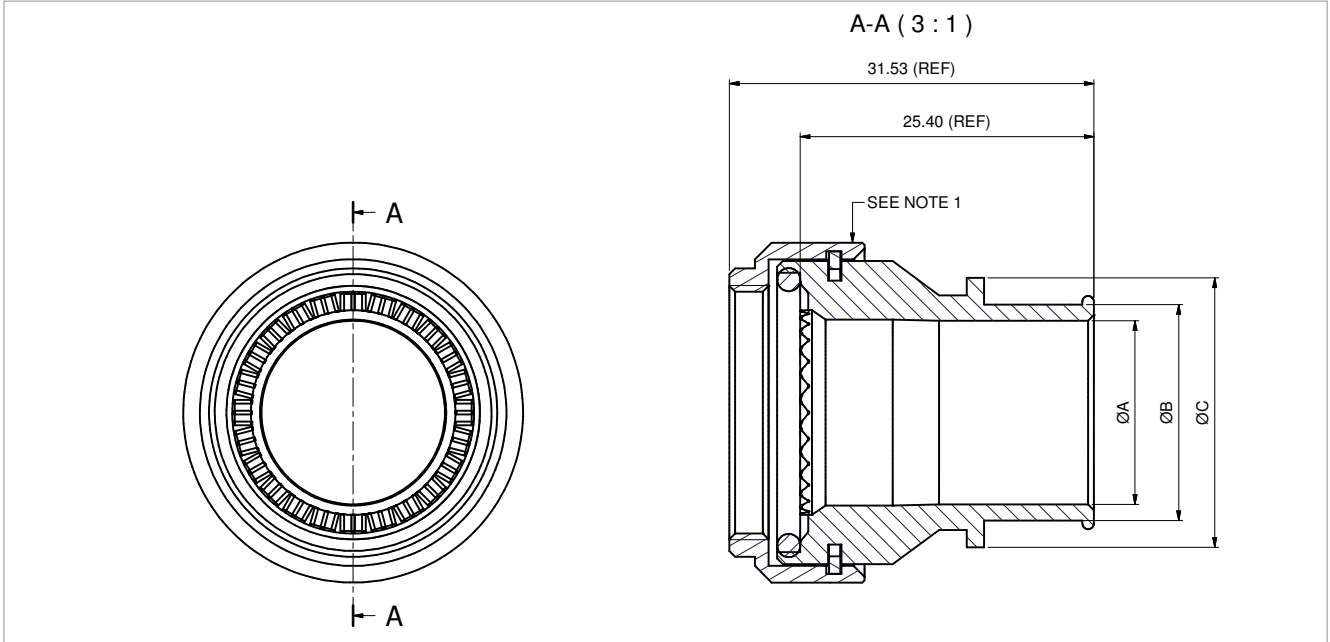

Table 1

Cable Entry Size	A Ø min.	B Ø max.	C Ø max.
03	4.77	9.75	13.70
04	6.35	9.75	13.70
05	7.92	10.72	15.30
06	9.52	12.32	17.00
07	11.10	13.90	18.50
08	12.70	15.50	20.10
09	14.27	17.07	21.70
10	15.88	18.68	23.30
11	17.47	20.27	24.90
12	19.05	21.85	26.50
13	20.62	23.42	28.10
14	22.23	25.03	29.70
15	23.82	26.62	31.30
16	25.40	28.20	32.90
17	27.00	29.80	34.50
18	28.60	31.40	36.10
19	30.20	33.00	37.70
20	31.80	34.60	39.30
21	33.38	36.18	40.90
22	35.00	37.80	42.50
23	36.58	39.38	44.10

Assembly: ABAC.01 . ## . # 15



ABAC

right angle backshell for band termination & heat shrink boot

Style: ABAC 03

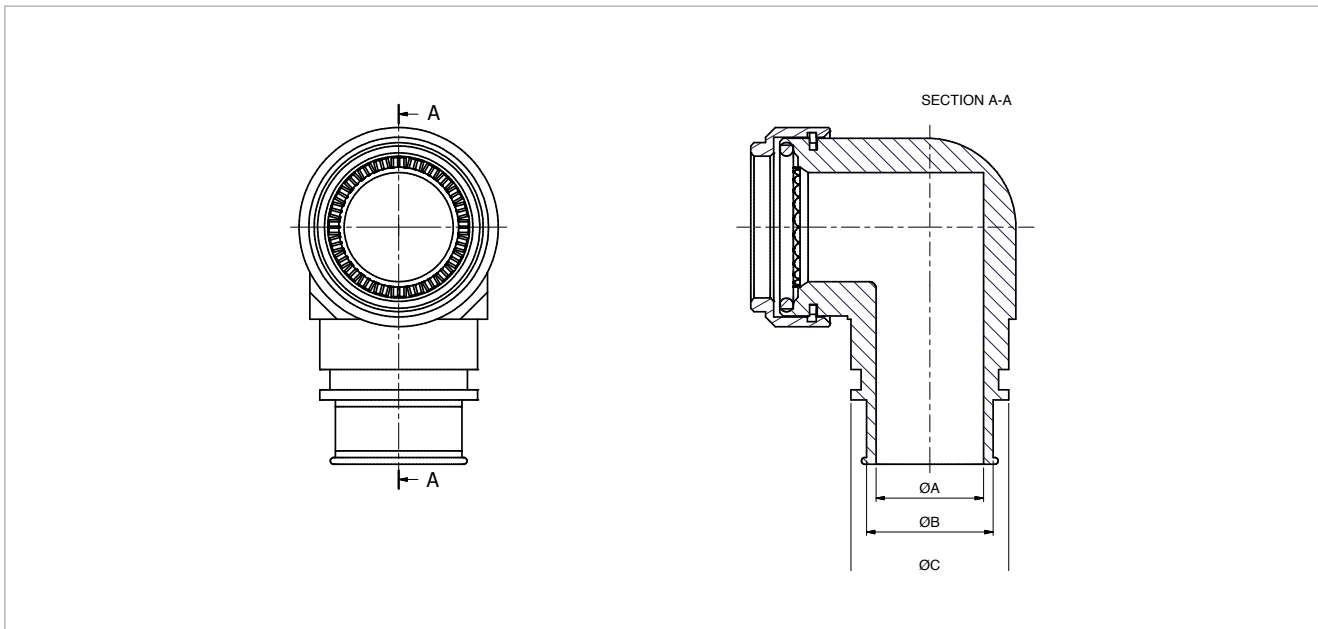

Table 1

Cable Entry Size	A Ø min.	B Ø max.	C Ø max.
03	4.77	9.75	13.70
04	6.35	9.75	13.70
05	7.92	10.72	15.30
06	9.52	12.32	17.00
07	11.10	13.90	18.50
08	12.70	15.50	20.10
09	14.27	17.07	21.70
10	15.88	18.68	23.30
11	17.47	20.27	24.90
12	19.05	21.85	26.50
13	20.62	23.42	28.10
14	22.23	25.03	29.70
15	23.82	26.62	31.30
16	25.40	28.20	32.90
17	27.00	29.80	34.50
18	28.60	31.40	36.10
19	30.20	33.00	37.70
20	31.80	34.60	39.30
21	33.38	36.18	40.90
22	35.00	37.80	42.50
23	36.58	39.38	44.10
24	38.10	40.90	45.70

Assembly: ABAC.03 . ## . # ##

Cable entry size
(see table 1)

Shell Size
Class / Finish

ABAC

straight screen trap adapter

Style: ABAC 10

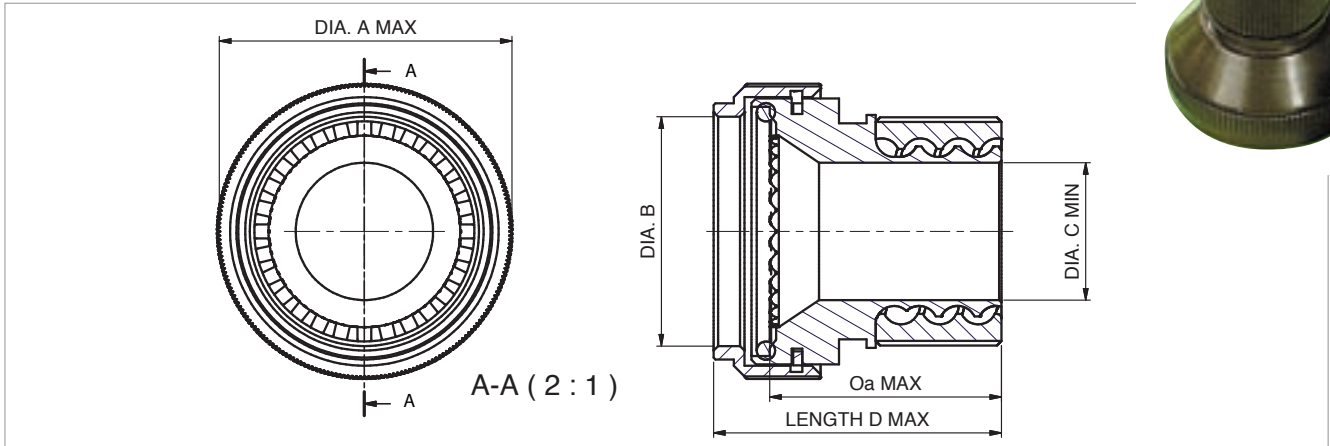

ABAC . 10 . ## . # 21



Cable Size	ØC	Length D Max	Oa max
03	4.70	28.58	22.00
04	6.30		
05	7.90		
06	9.50		
07	11.10		
08	12.70	33.88	27.30
09	14.20		
10	15.80		
11	17.40		
12	19.00		
13	20.60		
14	22.20		
15	23.80		
16	25.40		
17	27.00		
18	28.60		
19	30.20		
20	31.80		
21	33.30		
22	35.00		
23	36.50		
24	38.10		



ABAC

90° angled screen trap adapter

Style: ABAC 07

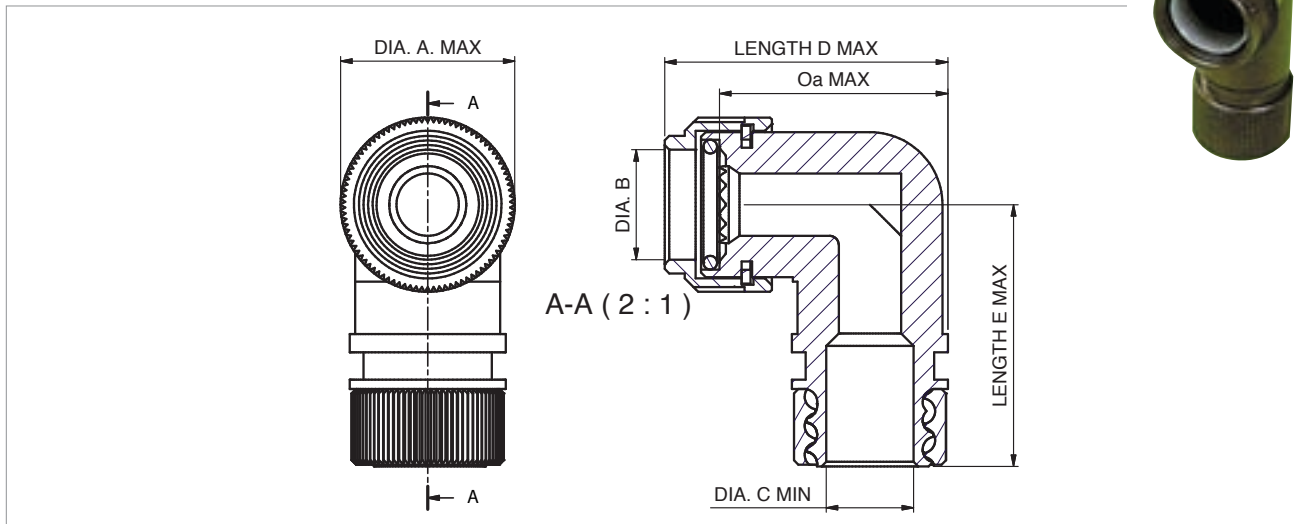

ABAC . 07 . ## . # 21

Accessory Style
Cable Entry Size

Connector Size
Class / Finish

Cable Size	ØC	Length D Max	Length E Max	Oa max
03	4.70	32.79	38.35	26.41
04	6.30	32.79		26.41
05	7.90	33.57		27.19
06	9.50	35.22		28.84
07	11.10	36.76		30.38
08	12.70	38.36	43.55	31.98
09	14.20	39.94		33.56
10	15.80	41.55		35.17
11	17.40	43.14		36.76
12	19.00	44.73		38.35
13	20.60	46.32		39.94
14	22.20	47.92		41.54
15	23.80	49.52		43.14
16	25.40	50.76		44.38
17	27.00	51.56		45.18
18	28.60	52.12		45.74
19	30.20	52.29		45.91
20	31.80	52.94		46.56
21	33.30	53.74		47.36
22	35.00	54.54	48.16	
23	36.50	55.34	48.96	
24	38.10	56.68	50.30	

ABAC

fixed protective caps

Style: ABAC 33-*-*R Part Number: D38999 33-*-*R

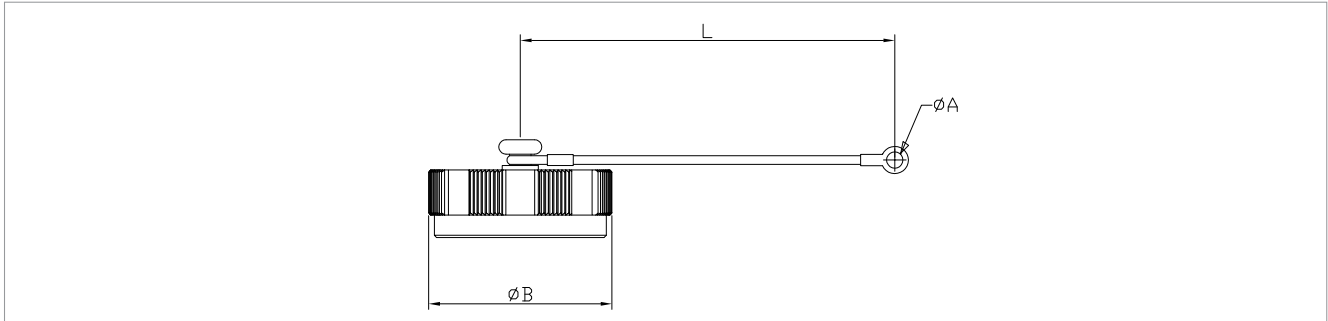

Shell Size	AB Part No.	A Ø min.	B Ø max.	L + 12.7 - 6.35	38999 Part No.
09	ABAC / 33 # 09 R	3.90	22.86	127	D38999 / 33 # 09 R
11	ABAC / 33 # 11 R	3.90	27.96	127	D38999 / 33 # 11 R
13	ABAC / 33 # 13 R	3.90	30.48	127	D38999 / 33 # 13 R
15	ABAC / 33 # 15 R	3.90	31.75	127	D38999 / 33 # 15 R
17	ABAC / 33 # 17 R	3.90	36.83	127	D38999 / 33 # 17 R
19	ABAC / 33 # 19 R	3.90	38.10	127	D38999 / 33 # 19 R
21	ABAC / 33 # 21 R	3.90	41.91	127	D38999 / 33 # 21 R
23	ABAC / 33 # 23 R	3.90	44.45	127	D38999 / 33 # 23 R
25	ABAC / 33 # 25 R	3.90	48.26	127	D38999 / 33 # 25 R

Note: replace # with desired plating finish.

ABAC

fixed protective caps

Style: ABAC 33-*-*N Part Number: D38999 33-*-*N

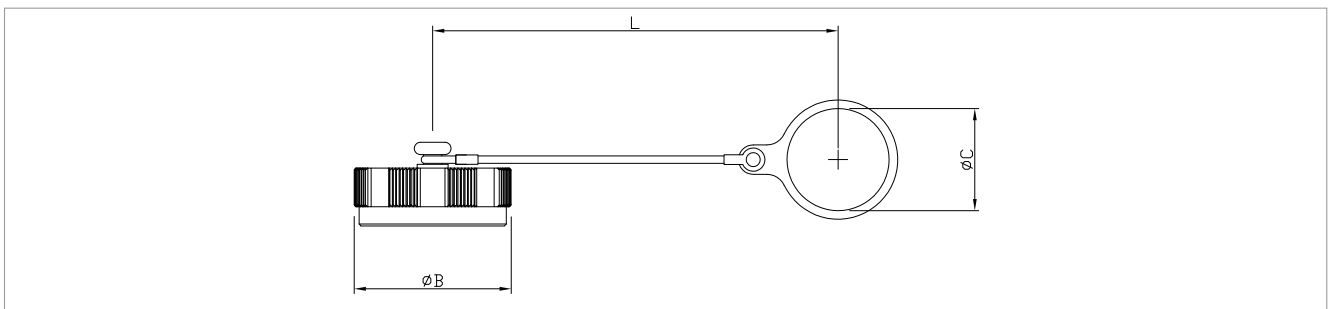

Shell Size	AB Part No.	C Ø min.	B Ø max.	L + 12.7 - 6.35	38999 Part No.
09	ABAC / 33 # 09 N	17.64	22.86	127	D38999 / 33 # 09 N
11	ABAC / 33 # 11 N	21.97	27.96	127	D38999 / 33 # 11 N
13	ABAC / 33 # 13 N	25.12	30.48	127	D38999 / 33 # 13 N
15	ABAC / 33 # 15 N	29.92	31.75	127	D38999 / 33 # 15 N
17	ABAC / 33 # 17 N	32.00	36.83	127	D38999 / 33 # 17 N
19	ABAC / 33 # 19 N	36.27	38.10	127	D38999 / 33 # 19 N
21	ABAC / 33 # 21 N	38.25	41.91	127	D38999 / 33 # 21 N
23	ABAC / 33 # 23 N	42.62	44.45	127	D38999 / 33 # 23 N
25	ABAC / 33 # 25 N	44.45	48.26	127	D38999 / 33 # 25 N

Note: replace # with desired plating finish.

ABAC

free protective caps

Style: ABAC 32-*-*^{-R/N} Part Number: D38999 32-*-*^{-R/N}

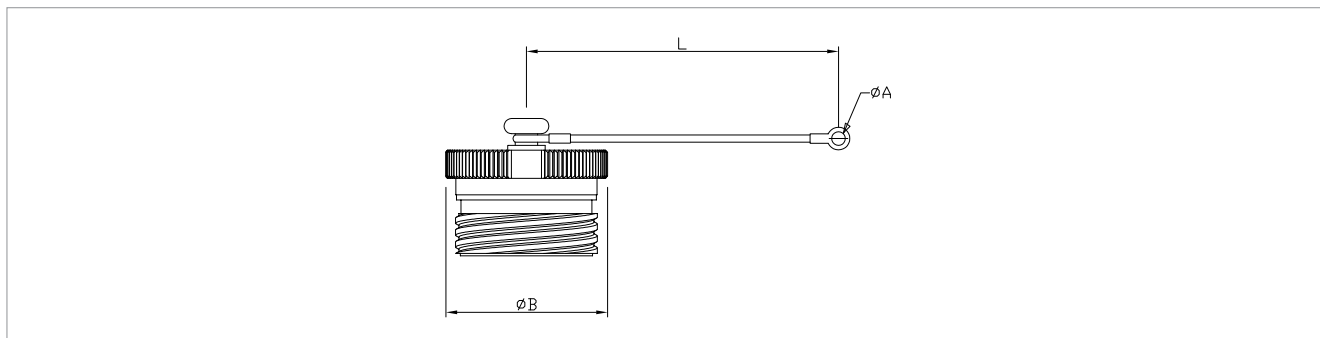

Shell Size	AB Part No.	A Ø min.	B Ø max.	L + 12.7 - 6.35	38999 Part No.
09	ABAC / 32 # 09 R	3.90	22.86	127	D38999 / 32 # 09 R
11	ABAC / 32 # 11 R	3.90	27.96	127	D38999 / 32 # 11 R
13	ABAC / 32 # 13 R	3.90	30.48	127	D38999 / 32 # 13 R
15	ABAC / 32 # 15 R	3.90	31.75	127	D38999 / 32 # 15 R
17	ABAC / 32 # 17 R	3.90	36.83	127	D38999 / 32 # 17 R
19	ABAC / 32 # 19 R	3.90	38.10	127	D38999 / 32 # 19 R
21	ABAC / 32 # 21 R	3.90	41.91	127	D38999 / 32 # 21 R
23	ABAC / 32 # 23 R	3.90	44.45	127	D38999 / 32 # 23 R
25	ABAC / 32 # 25 R	3.90	48.26	127	D38999 / 32 # 25 R

Note: replace # with desired plating finish.

ABAC

free protective caps

Style: ABAC 32-*-*^{-N} Part Number: D38999 32-*-*^{-N}

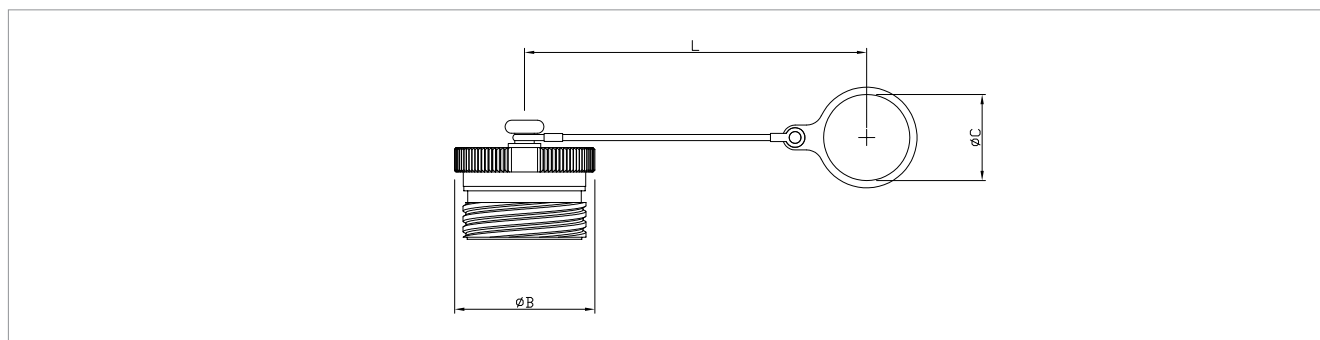

Shell Size	AB Part No.	C Ø min.	B Ø max.	L + 12.7 - 6.35	38999 Part No.
09	ABAC / 32 # 09 N	17,64	22,86	127	D38999 / 32 # 09 N
11	ABAC / 32 # 11 N	21,97	27,96	127	D38999 / 32 # 11 N
13	ABAC / 32 # 13 N	25,12	30,48	127	D38999 / 32 # 13 N
15	ABAC / 32 # 15 N	29,92	31,75	127	D38999 / 32 # 15 N
17	ABAC / 32 # 17 N	32,00	36,83	127	D38999 / 32 # 17 N
19	ABAC / 32 # 19 N	36,27	38,10	127	D38999 / 32 # 19 N
21	ABAC / 32 # 21 N	38,25	41,91	127	D38999 / 32 # 21 N
23	ABAC / 32 # 23 N	42,62	44,45	127	D38999 / 32 # 23 N
25	ABAC / 32 # 25 N	44,45	48,26	127	D38999 / 32 # 25 N

Note: replace # with desired plating finish.

ABAC

stowage receptacle

Style: ABAC 22-**-* Part Number: D38999 22-**-*

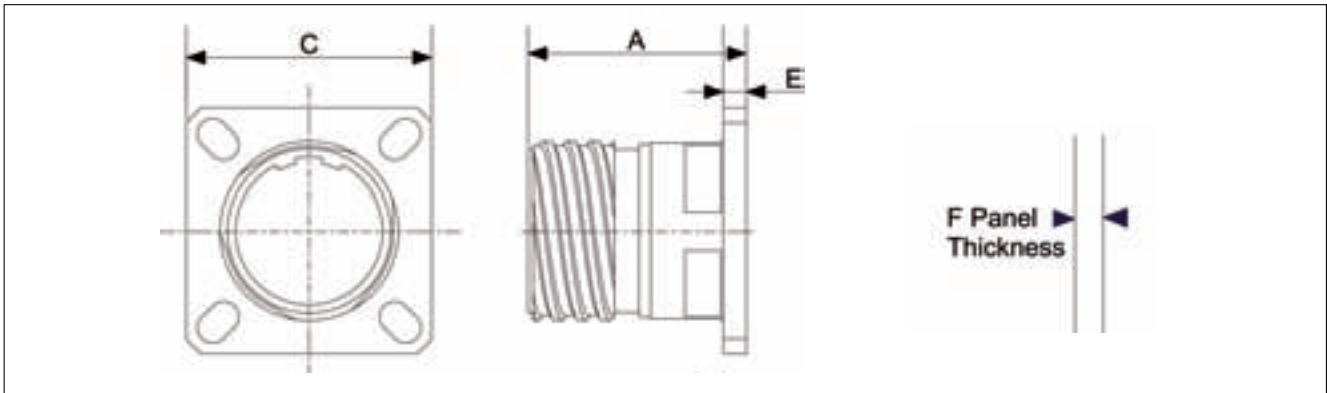

Shell Size	A max.	C +/- 0.3	E +/- max. 0.3	F	AB Part No.
09	24.2	23.8	2.5	5.94	ABAC 22 09 #
11	24.2	26.2	2.5	5.94	ABAC 22 11 #
13	24.2	28.6	2.5	5.94	ABAC 22 13 #
15	24.2	31.0	2.5	5.94	ABAC 22 15 #
17	24.2	33.3	2.5	5.94	ABAC 22 17 #
19	24.2	36.5	2.5	5.94	ABAC 22 19 #
21	24.1	39.7	3.2	5.18	ABAC 22 21 #
23	24.1	42.90	3.2	5.18	ABAC 22 23 #
25	24.1	46.0	3.2	5.18	ABAC 22 25 #

Note: replace # with desired plating finish.

ABAC

screened gaskets

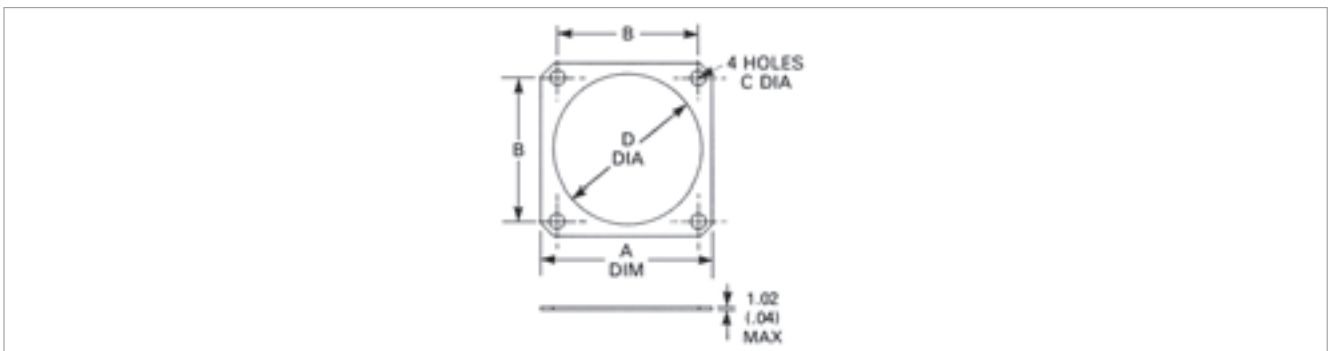

Shell Size	AB Part No.	A max.	B CRS	C Ø	D Ø min.
09	508/2/38401/109	24.33	18.26	3.12	14.22
11	508/2/38401/111	26.70	20.62	3.12	17.02
13	508/2/38401/113	29.08	23.01	3.12	21.08
15	508/2/38401/115	31.47	24.61	3.12	24.38
17	508/2/38401/117	33.83	26.97	3.12	27.43
19	508/2/38401/119	37.03	29.36	3.12	30.73
21	508/2/38401/121	40.18	31.75	3.12	33.78
23	508/2/38401/123	43.38	34.93	3.61	37.08
25	508/2/38401/125	46.53	38.10	3.61	40.13

ABAC contacts

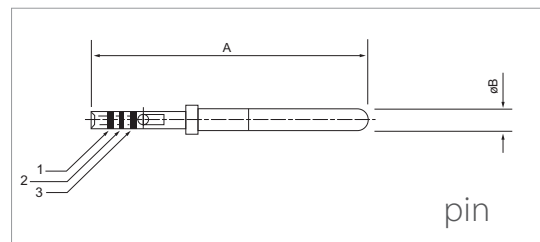
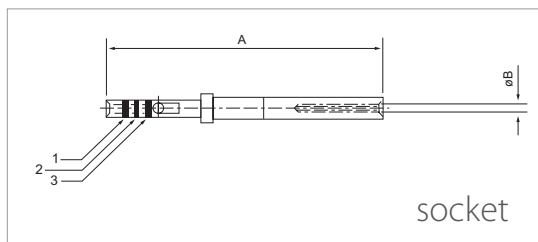

SIZE			SOCKET		PIN		Finished Wire Outside Dimensions			
Contact	Barrel	Wiring Size AWG	MIL-DTL part no.	AB Part no.	MIL-DTL part no.	AB Part no.	Min. inches	Min. mm	Max. inches	Max. mm
22D	22D	28, 26, 24, 22	M 39029/58-348	523/4/18241/000	M 39029/58-360	523/4/18219/000	0.030	0.076	0.054	1.370
20	20	24, 22, 20	M 39029/56-351	523/4/18242/000	M 39029/58-363	523/4/18225/000	0.040	1.020	0.083	2.110
16	16	20, 18, 16	M 39029/58-352	523/4/18243/000	M 39029/58-364	523/4/18227/000	0.650	1.650	0.109	2.770
12	12	14, 12	M 39029/56-353	523/4/18244/000	M 39029/58-365	523/4/18229/000	0.097	2.460	1.420	3.610
12	coax		M 39029/75-416		M 39029/28-24					
12	coax		M 39029/103-559		M 39029/102-558					
8	twinax		M 39029/91-530		M 39029/90-529		0.124	3.150	0.155	3.940
8	coax		M 39029/59-366		M 39029/60-367					
8	power	consult factory		523/4/18327/000		523/4/18326/000	0.124	3.150	0.155	3.940

ABAC contacts for use with pcb tail

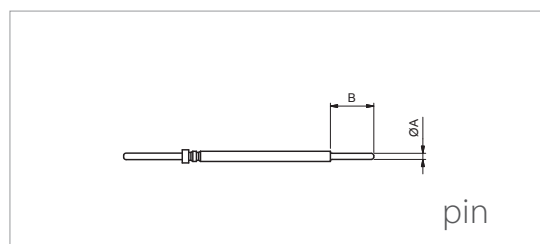
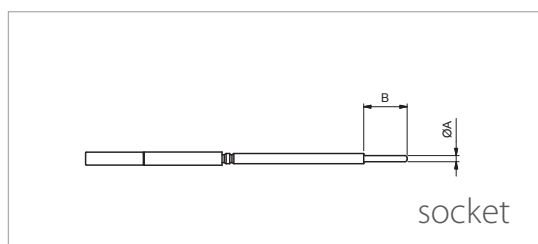

Contacts			
Contact Size	Mod Code Ref.	ØA	B
22D	M03	0.70	8.50
22D	M09	0.70	4.00
22D	M10	0.50	5.10
20	M09	0.70	5.10
16	M09	1.15	5.10

Contact	Part No.
Size 22D pin contact with PCB tail	514.2.18970.###
Size 22D socket contact with PCB tail	514.2.18977.###
Size 20 pin contact with PCB tail	514.2.18971.###
Size 20 socket contact with PCB tail	514.2.18978.###
Size 16 pin contact with PCB tail	514.2.18972.###
Size 16 socket contact with PCB tail	514.2.18979.###

ABAC grommet filler plugs



Size	Colour Code	MS No./Size	Catalogue No.
22D	Black	MS27488-22	523/2/18230/004
20	Red	MS27488-20	523/2/18230/003
16	Blue	MS27488-16	523/2/18230/002
12	Yellow	MS27488-12	523/2/18230/001

ABAC

insertion & extraction

The 38999 insertion and extraction tools have been designed for ease of use for operation and dependability. When harnesses are regularly produced using 38999 connectors these tools are highly recommended to replace the temporary tools provided with the connector. The wire gripping feature provides for extraction, without damage to either contact, wire or the sealing features. The metal tips provide the proper balance between the hardness necessary for long usage and the resiliency needed to prevent tip breakage under constant use.



Contact Size	Contact Part No.	Insertion Tool Part No.	Extraction Tool Part No.
22D	523/4/18219/000 523/4/18241/000	558/I/05267/000	558/I/05254/002
20	523/4/18225/000 523/I/18242/000	558/I/05253/000	558/I/05254/000
16	523/4/18227/000 523/4/18243/000	558/I/05251/000	558/I/5252/000
12	523/4/18229/000 523/4/18244/000	558/I/05251/001	558/I/05252/001
8	523/4/18248/000 523/4/18249/000	558/1/05307/001	558/1/05308/001

Crimping Tools

Tools conforming to MIL-C-22520 can be used to crimp 38999 connector contacts.

Recommendation for the various contact types and sizes are as follows:

The following crimp tools are all available from the approved MIL. Spec. tool manufacturers.

Crimping Tool	Positioner or Turret Die	Contact Type / Size
M22520/2-01 M22520/7-01	M22520/2-09 M22520/7-07	22D, Pins
M22520/2-01 M22520/7-01	M22520/2-07 M22520/7-05	22D, Socket
M22520/1-01 M22520/2-01 M22520/7-01	M22520/1-04 M22520/2-10 M22520/7-08	20 Pin, 20 Socket
M22520/1-01 M22520/7-01	M22520/1-04 M22520/7-04	16 Pin, 16 Socket
M22520/1-01	M22520/1-04	12 Pin, 12 Socket

Size 8 Twinax Crimping Tool:

Crimping Tool	Positioner or Turret Die	Contact Type / Size
M22520/2-01	K709	Inner Contact
M22520/5-01	Y631	Intermediate Contact & Outer Contact

ABAC

contact insertion

Tool Description

AB Connectors Insertion tools (Fig. 1) are designed to install pin and socket contacts into the MIL-DTL-38999 contact retention system. Positive retention of contacts is accomplished by allowing the locking tabs of the contact retaining spring to engage behind the contact shoulder.

Preparation for Insertion

1. Remove grommet nut or outlet from the connector and place over the wires to be installed.
2. Insert the crimped contact / wire assembly between the tool tips, making sure that contact shoulder is butted against tips.

Insertion Procedure

3. Align contact and tool with the selected hole in the connector as nearly perpendicular to the grommet face as possible (Fig. 2).
4. Carefully push the contact into the rubber grommet hole and hard dielectric insert body until the contact shoulder stops against the insert. The contact retaining spring will then be felt or heard locking into place (Fig. 3).

CAUTION: Do not squeeze the plastic tool handles while the tool tips are inside the connector, Spreading, angling, or rotating the tips can damage them and the connector.

5. Withdraw the tool completely from the connector by sliding it back along the wire insulation. Remove tool and apply a gentle pull on the wire to confirm that the contact is properly locked into place.
6. Install all other wired contacts in the same manner. Unused holes must be filled with an unwired contact followed by a sealing plug.
7. Reassemble grommet nut or outlet.

Fig. 1

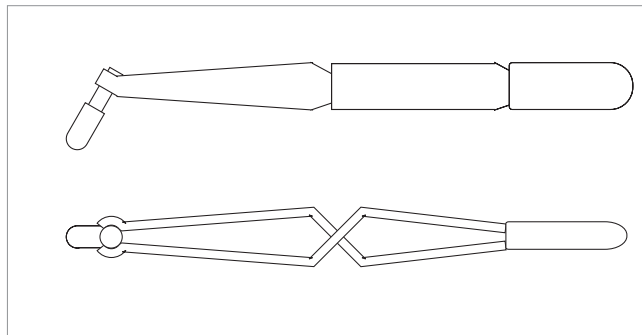

Fig. 2

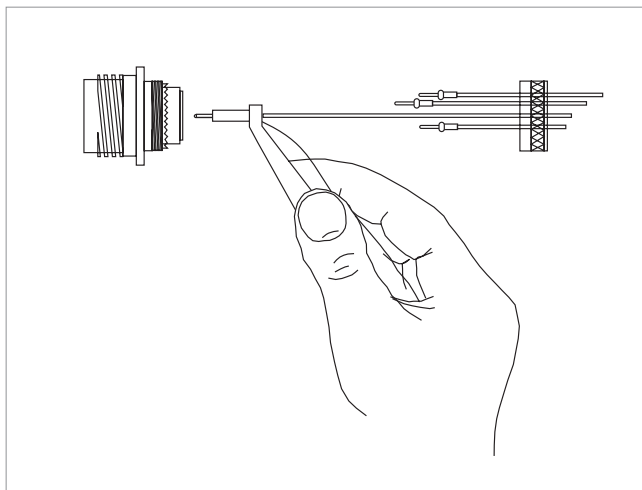
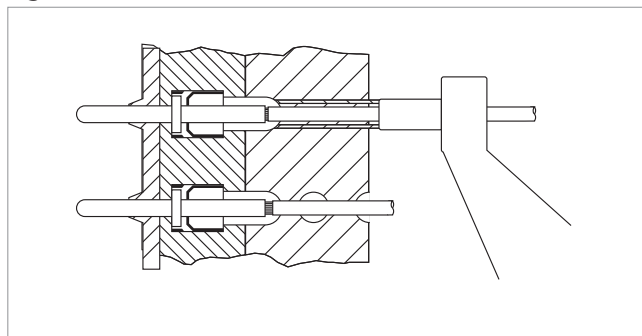

Fig. 3



ABAC

contact extraction

Tool Description

AB Connectors Extraction tools (Fig. 1a) are designed to extract pin and socket contacts from the MIL-DTL-38999 contact retention system. Extraction of contacts is accomplished by releasing the locking tabs of the contact retaining spring.

Preparation for Extraction

1. Disassemble grommet nut or outlet from the connector, allowing it to hang on the wire bundle.
2. Insert the wire of the contact to be extracted between the tool tips (Fig 2a)

Extraction Procedure

3. Slide the tool tips down the wire insulation into the rubber sealing grommet and hard dielectric insert body until they stop against the contact shoulder (Fig. 3a). If tips catch on the wire barrel and will not enter to full depth, remove tool completely and open and close handles to realign tips.

CAUTION: Do not squeeze the plastic tool handles while the tool tips are inside the connector. Spreading, angling, or rotating the tips can damage them and the connector.

4. With the tool tips firmly butted against the contact shoulder, grip the wire insulation against the serrated tool surface without permitting any slack, and exert a light pull on the tool and wire to extract the contact (Fig. 4a). Do not increase pull if contact does not slide out easily - tool tips were not butted properly and excessive tension will damage the contact retaining spring. Remove tool completely and repeat extraction procedure.
5. If wired contact is not replaced, fill unused holes with an unwired contact followed by a sealing plug.
6. Reassemble grommet nut or outlet.

Fig. 1a

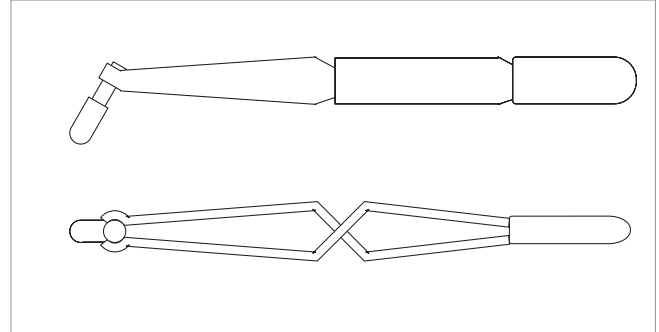

Fig. 2a

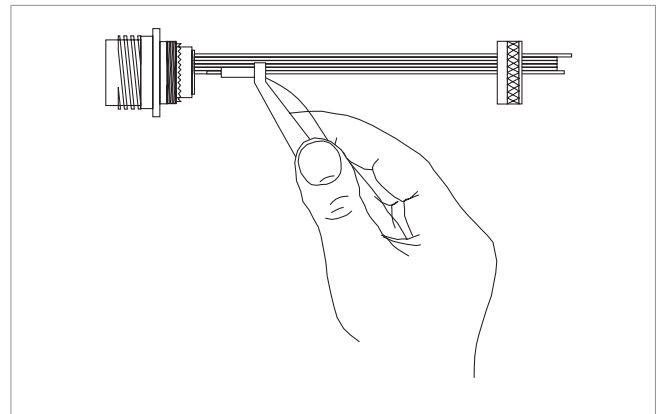

Fig. 3a

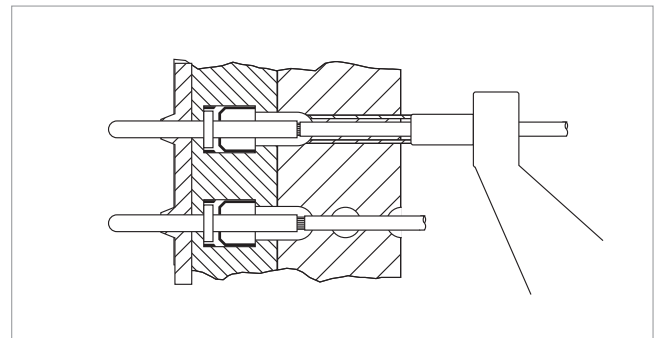
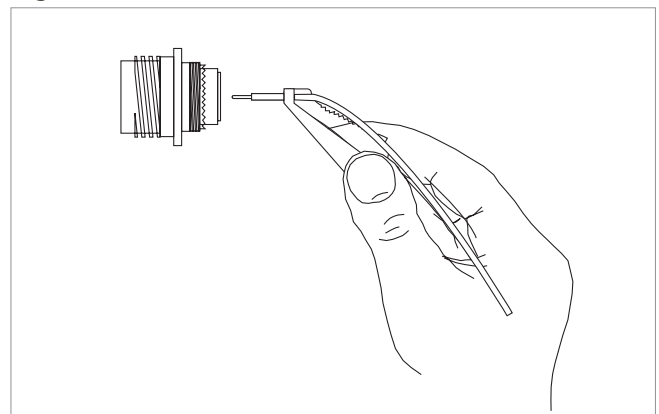

Fig. 4a



ABAC

safety information

This information is to be used in conjunction with the Product Catalogue and Product Specification. Products may be safely used in the applications for which they have been designed and within the specified ratings and environments. If products are exposed to conditions outside the performance ratings or specified environments they may constitute a hazard. In particular it should be noted that:-

1. Material Content of Products.

Circular Connectors generally use metalwork parts made of copper, copper alloy, aluminium alloy, aluminium-bronze, phosphor-bronze or steel, which, dependant on the particular application, may be passivated and protected with cadmium or zinc plate – in conjunction with chromated or anodised surface finishes. The insulating materials can be either natural or synthetic rubber, together with plastic or glass filled plastic moulded parts. Contact materials vary with product type but are usually made of copper, copper alloy, nickel, phosphor-bronze, alumel, chromel or steel.

2. Electric Shock, Burns and Fire.

Hazard can occur if the product is used outside the specified parameters or if the product is damaged, wrongly wired or poorly assembled, or poorly integrated into larger equipment, or contaminated with conductive fluids. Live circuit terminations must be protected and live circuits never broken by demating products.

Hotspots may be created when resistance is increased due to damage or incorrect integration particularly soldering, crimping or loose terminations. Overheating can cause breakdown of insulation, electric shot, burns or, ultimately, fire. In the event of fire noxious and/or toxic fumes may be released and, in these circumstances, any fire involving the product should be dealt with by personnel properly equipped.

Connector products with exposed terminators or contacts should not be used on the current supply side of a circuit with exposed contacts on an unmated product. Before making a circuit live, the product and wiring should be checked to ensure that there is no damage and no electrically conducting debris present. Circuit resistance checks should also be conducted before making the circuit live. Always ensure that the correct tools, (specified by AB Connectors Ltd.) are employed for crimping and assembly and that connectors are assembled and wired by properly trained personnel.

3. Disposal of Products.

Products should not be burnt.

4. Use Transport and Storage of Products.

Care must be exercised to avoid damage to any part of the products during transporting, storage or use. The products, as manufactured, are free of sharp edges. Abnormal transit or storage conditions and abuse during installation can give rise to damage. Products should not be used in a damaged condition. Improper storage (particularly of damaged products) can give rise to additional hazards particularly corrosion. Your attention is specifically drawn to the need of proper storage of products containing cadmium and you are advised to see the Guidance Note from the Health and Safety Executive on Cadmium - Health and Safety Precautions.

Safety Rules

1. Ensure all conductor wires are capable of withstanding the electrical and environmental conditions of the application.
2. Always use the correct assembly tools for cables, contacts and connectors.
3. Make circuit resistance checks before making a circuit live.
4. Always protect live circuits and never demate a live connector.
5. Never use a damaged connector.
6. Never burn discarded connectors or cable.
7. IF IN DOUBT, ASK.

N. B. Additional information on the products and the materials used in them may be obtained from the Sales Department of AB Connectors Ltd.

Shelf life for rubber components

AB Connectors incorporate a number of rubber components within their connectors. Most rubbers change in physical properties during storage e.g. excessive hardening, softening, cracking or other surface degradation. These changes may be the result of particular factors or a combination of factors such as light, heat, humidity, oils or solvents.

With a few simple precautions the shelf life may be considerably lengthened.

The storage temperature should be between +5 and +25 degrees C. Direct contact with sources of heat such as boilers, radiators and direct sunlight should be avoided. It is advisable to cover any windows of storage rooms with a red or orange coating or screen. The relative humidity in the storeroom should be below 70%. Very moist or very dry conditions should be avoided. Condensation should not occur.

If the above recommendations are adhered to, then AB Connectors would warrant a shelf life of four years for its products.

N. B. The company reserves the right and may change or vary specification without prior written notice.

TT electronics and the environment

TT electronics companies adopt a responsible attitude towards the protection of the environment

We strive to meet the requirements of all applicable environmental laws and regulations, to continuously improve environmental performance and to contribute to long-term economic, environmental and social sustainability.

As part of TT electronics' Group Corporate Social Responsibility (CSR) Programme, we engage with industry bodies, like the Electronics Industry Citizenship Coalition (EICC) and Carbon Trust, to support these goals and to maintain ethical supply chains.

The CSR programme has opened up a network for TT electronics, across industry leading bodies, helping us to benchmark our environmental approach.

Environmental Deployment:

- Each site is encouraged to attain the latest quality and environmental accreditation and companies have attained ISO 9001, ISO 14001, QS 900 and TS16949, where appropriate.
- Our companies utilise energy efficient means of manufacture and seek to reduce, reuse and recycle waste and arrange for disposal of other waste responsibly.

In collaboration with customers and suppliers, TT electronics' product and process development engineers work continuously to meet the demands of a more environmentally demanding market place. With every new vehicle platform, the increasing use of electronics enables improved techniques to be utilised for reducing emissions and improving fuel economy. The continued drive for a cleaner environment is behind research and development into future generations of vehicles and personal transport systems. Many of these will incorporate new and novel forms of power plants including hybrid engines, fuel cells and plug in electrics. These exciting and technically advanced power sources will be controlled using new generations of electronic functional systems incorporating technology from TT electronics in the form of components and systems.

TT electronics companies have invested, heavily, in design engineering, process control and modern manufacturing equipment. An essential part of product development is the validation of products to customer specific requirements. In most of our companies, this process is carried out in-house on independently certified test and validation facilities. We are committed to partnerships with suppliers and encourage a talented, fully involved and committed workforce to achieve our objectives.

Each of our businesses adopts a high level of customer focus, and is committed to continuous improvement by utilising tools and methods including lean manufacture, Kaizen and Six- Sigma.

We believe that the ultimate measure of quality is customer satisfaction and that continued growth must be based on optimising and improving our quality performance.

Global Sales Offices



North America

Email: sales@ttelelectronics-na.com

Europe

Email: sales@ttelelectronicseurope.com

Asia

Email: sales@ttelelectronicsasia.com



TT electronics Clive House, 12-18 Queens Road, Weybridge, Surrey, KT13 9XB, UK
www.ttelelectronics.com Email: info@ttelelectronics.com



AB Connectors Limited Abercynon, Mountain Ash, Rhondda Cynon Taff, CF45 4SF
+44 (0) 1443 740331 www.ttabconnectors.com sales@ttabconnectors.com

www.ttelectronics.com



Компания «ЭлектроПласт» предлагает заключение долгосрочных отношений при поставках импортных электронных компонентов на взаимовыгодных условиях!

Наши преимущества:

- Оперативные поставки широкого спектра электронных компонентов отечественного и импортного производства напрямую от производителей и с крупнейших мировых складов;
- Поставка более 17-ти миллионов наименований электронных компонентов;
- Поставка сложных, дефицитных, либо снятых с производства позиций;
- Оперативные сроки поставки под заказ (от 5 рабочих дней);
- Экспресс доставка в любую точку России;
- Техническая поддержка проекта, помощь в подборе аналогов, поставка прототипов;
- Система менеджмента качества сертифицирована по Международному стандарту ISO 9001;
- Лицензия ФСБ на осуществление работ с использованием сведений, составляющих государственную тайну;
- Поставка специализированных компонентов (Xilinx, Altera, Analog Devices, Intersil, Interpoint, Microsemi, Aeroflex, Peregrine, Syfer, Eurofarad, Texas Instrument, Miteq, Cobham, E2V, MA-COM, Hittite, Mini-Circuits, General Dynamics и др.);

Помимо этого, одним из направлений компании «ЭлектроПласт» является направление «Источники питания». Мы предлагаем Вам помощь Конструкторского отдела:

- Подбор оптимального решения, техническое обоснование при выборе компонента;
- Подбор аналогов;
- Консультации по применению компонента;
- Поставка образцов и прототипов;
- Техническая поддержка проекта;
- Защита от снятия компонента с производства.



Как с нами связаться

Телефон: 8 (812) 309 58 32 (многоканальный)

Факс: 8 (812) 320-02-42

Электронная почта: org@eplast1.ru

Адрес: 198099, г. Санкт-Петербург, ул. Калинина, дом 2, корпус 4, литера А.