



Scotchlok™ 560N

Self-Stripping Electrical Double Run Connectors



Data Sheet

Application

Use 3M™ Scotchlok™ Tap Connector 560N to electrically connect 2 (two) through (run) wires and insulate the connection.

Wire Range

18-14 AWG solid or Stranded, tinned or untinned (.75-1.5 mm²) copper conductors. For use with common thermoplastic insulated wires such as: T, TF, TFF, TFN, TFFN, AWM, TEW, SAE-GPT with a maximum insulation diameter of .145 inches (3.5 mm). Maximum recommended current for general purpose applications: 18 AWG - 7 AMPS, 16 AWG - 10 AMPS, 14 AWG - 15 AMPS.

Construction

U-contact - Tin plated brass, .03 in. (.8 mm) thick
 Insulator - Polypropylene
 Color - brown
 UL 94-V-2

Weight

.0032 lb. (1.45 gm)

Recommended Installation Tools

3M™ Crimping Tool No. E-9BM
 9" Linemans Pliers

Installation Instructions

⚠ WARNING

Turn power off before installing or removing terminal. All electrical work should be done according to appropriate electrical codes.

1. Open connector to allow run wire insertion.
2. Insert unstripped run wires from side and close connector firmly.
3. Hold tool perpendicular to the wires and make the connection by driving the u-contact down flush with the top of the plastic insulator.
4. Close hinged top cover until latched.

Regulatory Agencies

UL Listed - Tested per UL Standard 486C
 UL file No. E23438
 CSA certified - CSA Std. C22.2 No.188-MI983
 CSA File No. LR15503
 (Voltage rated at 600 volts maximum, building wire: 1000 volts maximum, signs, fixtures and luminaires. Operating Temperature: 105°C, 221°F maximum)

Note: UL Listed and CSA Certified for AWG only.

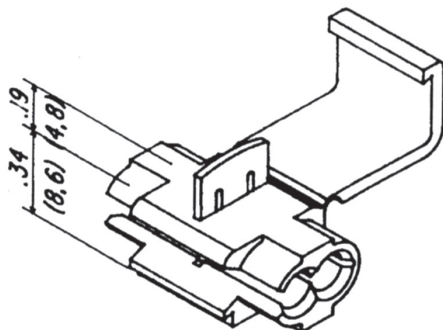

inch
(mm)

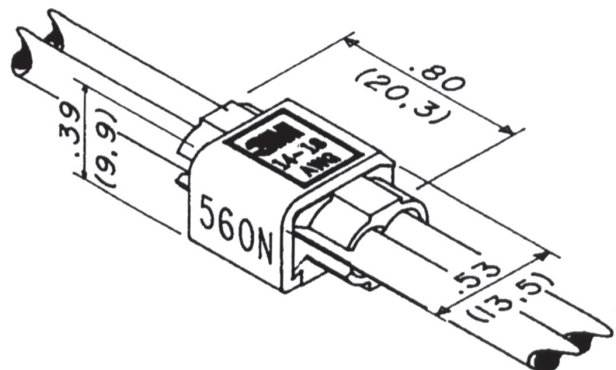

Engineering Specification

Self-Stripping Electrical Connector (as manufactured by 3M, part No. 560N) capable of connecting 2 (two) run wires in the range of No. 18 thru No. 14 AWG solid or stranded copper. Connector shall be UL Listed and CSA Certified for 600 volts maximum, building wire: 1000 volts maximum, signs, fixtures and luminaires, and have a maximum operating temperature of 105°C, 221°F.

3M and Scotchlok are trademarks of 3M Company.

 is a trademark of Underwriters Laboratories.

 is a trademark of Canadian Standards Association.

Important Notice

All statements, technical information, and recommendations related to 3M's products are based on information believed to be reliable, but the accuracy or completeness is not guaranteed. Before using this product, you must evaluate it and determine if it is suitable for your intended application. You assume all risks and liability associated with such use. Any statements related to the product which are not contained in 3M's current publications, or any contrary statements contained on your purchase order shall have no force or effect unless expressly agreed upon, in writing, by an authorized officer of 3M.

Warranty; Limited Remedy; Limited Liability.

This product will be free from defects in material and manufacture for a period of one (1) year from the time of purchase. **3M MAKES NO OTHER WARRANTIES INCLUDING, BUT NOT LIMITED TO, ANY IMPLIED WARRANTY OF MERCHANTABILITY OR FITNESS FOR A PARTICULAR PURPOSE.** If this product is defective within the warranty period stated above, your exclusive remedy shall be, at 3M's option, to replace or repair the 3M product or refund the purchase price of the 3M product. **Except where prohibited by law, 3M will not be liable for any indirect, special, incidental or consequential loss or damage arising from this 3M product, regardless of the legal theory asserted.**



Electrical Markets Division

6801 River Place Blvd.
Austin, TX 78726-9000
800-626-8381
Fax 800-828-9329
www.3M.com/electrical



Recycled paper
40% Pre-consumer waste paper
10% Post-consumer waste paper

Litho in USA
© 3M 2006 78-8126-5519-5-C



Компания «ЭлектроПласт» предлагает заключение долгосрочных отношений при поставках импортных электронных компонентов на взаимовыгодных условиях!

Наши преимущества:

- Оперативные поставки широкого спектра электронных компонентов отечественного и импортного производства напрямую от производителей и с крупнейших мировых складов;
- Поставка более 17-ти миллионов наименований электронных компонентов;
- Поставка сложных, дефицитных, либо снятых с производства позиций;
- Оперативные сроки поставки под заказ (от 5 рабочих дней);
- Экспресс доставка в любую точку России;
- Техническая поддержка проекта, помощь в подборе аналогов, поставка прототипов;
- Система менеджмента качества сертифицирована по Международному стандарту ISO 9001;
- Лицензия ФСБ на осуществление работ с использованием сведений, составляющих государственную тайну;
- Поставка специализированных компонентов (Xilinx, Altera, Analog Devices, Intersil, Interpoint, Microsemi, Aeroflex, Peregrine, Syfer, Eurofarad, Texas Instrument, Miteq, Cobham, E2V, MA-COM, Hittite, Mini-Circuits, General Dynamics и др.);

Помимо этого, одним из направлений компании «ЭлектроПласт» является направление «Источники питания». Мы предлагаем Вам помощь Конструкторского отдела:

- Подбор оптимального решения, техническое обоснование при выборе компонента;
- Подбор аналогов;
- Консультации по применению компонента;
- Поставка образцов и прототипов;
- Техническая поддержка проекта;
- Защита от снятия компонента с производства.



Как с нами связаться

Телефон: 8 (812) 309 58 32 (многоканальный)

Факс: 8 (812) 320-02-42

Электронная почта: org@eplast1.ru

Адрес: 198099, г. Санкт-Петербург, ул. Калинина, дом 2, корпус 4, литера А.