



Ordering a market-ready enclosure® is made fast and affordable with our complete in-house capabilities. New Age provides machined openings to fit your PCB, pad printing for your graphics, custom enclosures, custom colors, final assembly, testing and fulfillment services to save you additional time and money. Ask your representative for a free quote today 805-595-1310.

## ***Fast and Affordable Customization***

**CNC Modifications  
Pad Printing  
Colored Resins  
EMI/RF Shielding  
Custom Enclosure  
Assembly & Testing**



ISO quality  
off-the-shelf  
to market-ready®

# **NEW AGE ENCLOSURES**

[www.NewAgeEnclosures.com](http://www.NewAgeEnclosures.com)

4330 Santa Fe Road • San Luis Obispo, CA 93401 • T 805.595.1310 • F 805.595.1024

R E V I S I O N

| REV. | DRAWN BY | ECO No | DESCRIPTION                           | DATE      | APPROVED |
|------|----------|--------|---------------------------------------|-----------|----------|
| A    | M BOYER  |        | PRELIMINARY RELEASE                   | 15-Feb-13 | D.C.     |
| B    | M BOYER  |        | CHANGE TITLE                          | 21-Feb-13 | D.C.     |
| C    | M BOYER  |        | REVISE TEXTURE AND DRAFT ON ENDS      | 03-Apr-13 | D.C.     |
| D    | M BOYER  |        | ADD INSPECTION DIMENSIONS             | 10-Jul-13 | D.C.     |
| 1.0  | R CRUZ   |        | UPDATE TO AS BUILT AND RELEASE TO MFG | 10-Sep-13 |          |

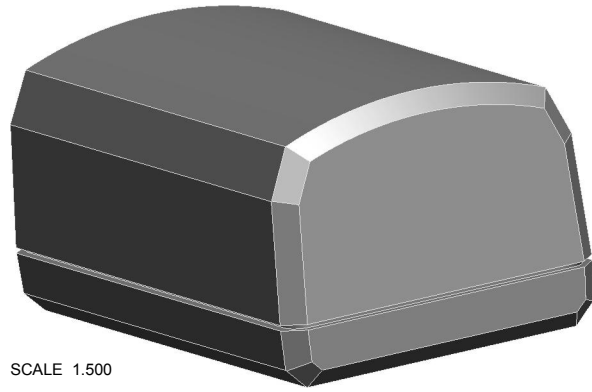

SCALE 1.500

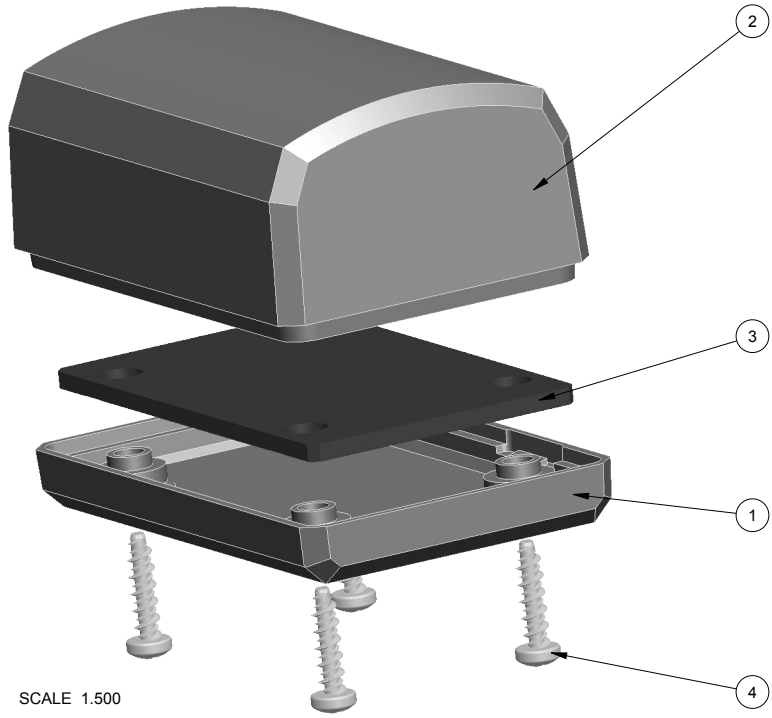

SCALE 1.500

NOTES: UNLESS OTHERWISE SPECIFIED

1. CORNERS DRAWN SHARP TO BE R.005 MAXIMUM.
2. EXTERIOR SURFACE TEXTURE TO BE LIGHT EDM FINISH. EQUIVELANT TO MT-1055-2, EXCEPT WHERE NOTED
3. INTERIOR SURFACE TEXTURE TO BE: NONE.
4. ALL INSIDE RADII .010R. UNLESS OTHERWISE SPECIFIED.
5. ALL EXTERNAL DIMENSIONS AFFECTED BY THE DRAFT APPLY AT THE LARGE END OF THE FEATURE, AND ALL INTERNAL FEATURES AFFECTED BY THE DRAFT APPLY AT THE SMALL END OF THE FEATURE UNLESS OTHERWISE SPECIFIED.
6. 1 DEGREE DRAFT IN THE DIRECTION OF PULL IS PERMISSIBLE UNLESS OTHERWISE SPECIFIED.
7. MATERIAL / COLOR: ABS PLASTIC IS STANDARD IN BLACK OR WHITE. CUSTOM MATERIALS AND COLORS ARE AVAILABLE UPON REQUEST FOR QUOTE.
8. PCB SIZES ARE RECOMMENDATIONS ONLY. FINAL SIZES AND VERIFICATION OF IT'S FIT ARE THE SOLE RESPONSIBILITY OF EACH OWNER.
9. ASSEMBLY SCREWS FOR THE ENCLOSURE INCLUDED.
10. THIS DRAWING IS BASED ON A SOLID MODEL, AND IS FURTHER DEFINED BY THE SOLID MODEL FILE.
11. ALLOWABLE FLASH: 0.010 MAX.

| ITEM | FILE NAME    | DESCRIPTION             | MATERIAL    | COLOR             | QTY. |
|------|--------------|-------------------------|-------------|-------------------|------|
| 4    | N02_HI-LO    | S-HiLo #2 x 3/8"        | ZINK        | INCLUDED          | 4    |
| 3    | 201209_PCB   | 201209 PCB - REFERENCE  | .062" THICK | CUSTOMER SUPPLIED | 1    |
| 2    | 201209_COVER | 201209 COVER - STANDARD | ABS         | BLACK or WHITE    | 1    |
| 1    | 201209_BASE  | 201209 BASE - STANDARD  | ABS         | BLACK or WHITE    | 1    |

BILL OF MATERIALS

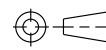
|   |  |   |
|---|--|---|
| THIRD ANGLE PROJECTION<br><br>DO NOT SCALE DRAWING | TOLERANCES: UNLESS OTHERWISE SPECIFIED DIMENSIONS ARE IN U.S. INCHES.<br>X.XX = .015 X.XXXX = .001<br>X.XXX = .010 X.X° = 1° | <h2 style="margin: 0;">NEW AGE ENCLOSURES</h2> 4330 Santa Fe Road San Luis Obispo, CA. 93401<br>ph. (805) 595-1310 fax (805) 595-1024<br><a href="http://www.newageenclosures.com">www.newageenclosures.com</a> |
| Customer's Part No: 201209  |  | <h3 style="margin: 0;">STANDARD - 2in DONGLE</h3> <h3 style="margin: 0;">SXX-201209-XXX</h3>  |
| APPROVAL _____ BY _____ DATE _____<br>CHECK _____<br>ENG. _____<br>SCALE AS NOTED   | DRAWN BY M BOYER 15-Feb-13   | SIZE A DRAWING NAME 201209_R1_0 SHEET 1 OF 6 REV.DOC 1.0  |

NOTICE: THE INFORMATION AND DATA CONTAINED HEREIN IS CONSIDERED PROPRIETARY TO ALLTEC INTEGRATED MFG INC & SHALL REMAIN THE EXCLUSIVE PROPERTY OF ALLTEC INTEGRATED MFG INC. THE HOLDER WILL ASSUME CUSTODY AND CONTROL THAT THIS DOCUMENT WILL NOT BE COPIED, REPRODUCED, OR DISCLOSED WITHOUT THE EXPRESS WRITTEN CONSENT OF ALLTEC INTEGRATED MFG INC. THIS DOCUMENT DOES NOT CONSTITUTE A GRANT TO MANUFACTURE ANY ITEMS. © 2013

# 201209 ASSEMBLY

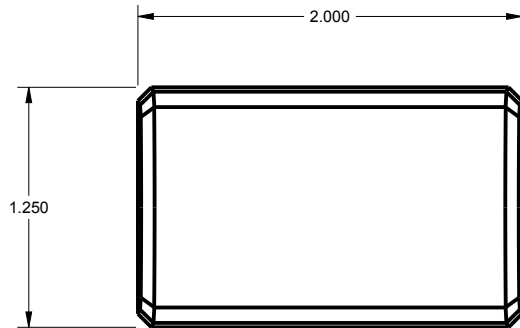
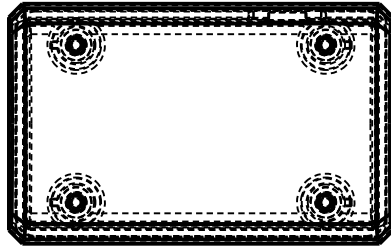

SCALE 1.000

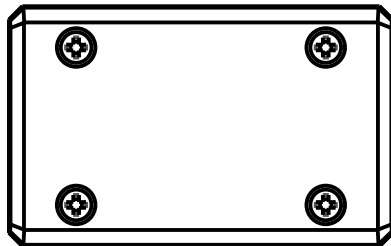
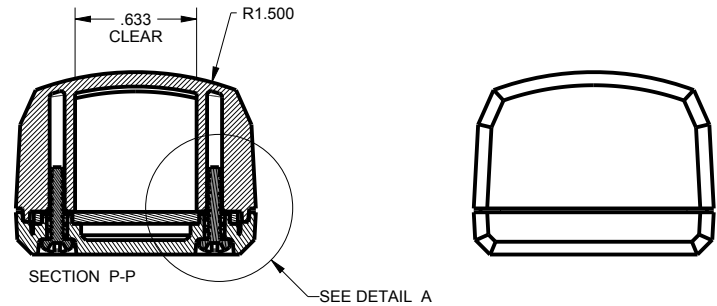
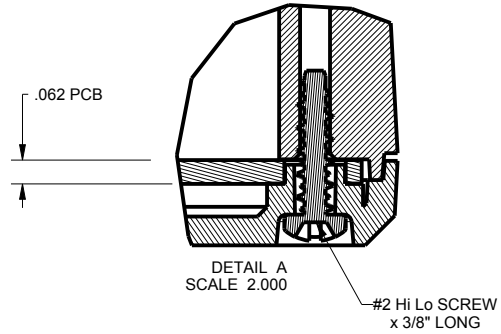
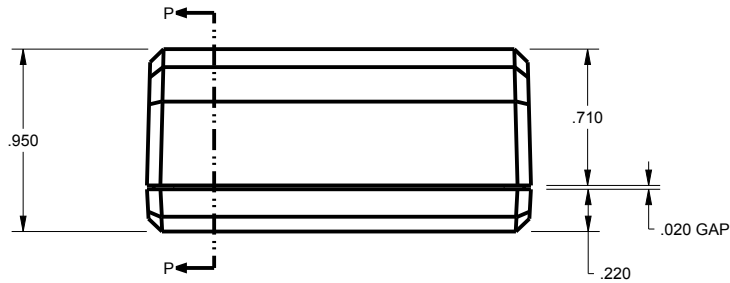

TOLERANCES: UNLESS OTHERWISE SPECIFIED  
DIMENSIONS ARE IN U.S. INCHES.  
X.XX = .015 X.XXXX = .001  
X.XXX = .010 X.X° = 1°

NEW AGE ENCLOSURES

Customer's Part No: 201209

|          |          |      |
|----------|----------|------|
| APPROVAL | BY       | DATE |
| CHECK    |          |      |
| ENG.     |          |      |
| SCALE    | AS NOTED |      |

DRAWN BY  
M BOYER

15-Feb-13

## NEW AGE ENCLOSURES

4330 Santa Fe Road San Luis Obispo, CA. 93401  
ph. (805) 595-1310 fax (805) 595-1024  
[www.newageenclosures.com](http://www.newageenclosures.com)

STANDARD - 2in DONGLE  
SXX-201209-XXX

SIZE  
A

DRAWING NAME  
201209\_R1\_0

SHEET  
2 OF 6

REV.DOC  
1.0

# 201209 COVER

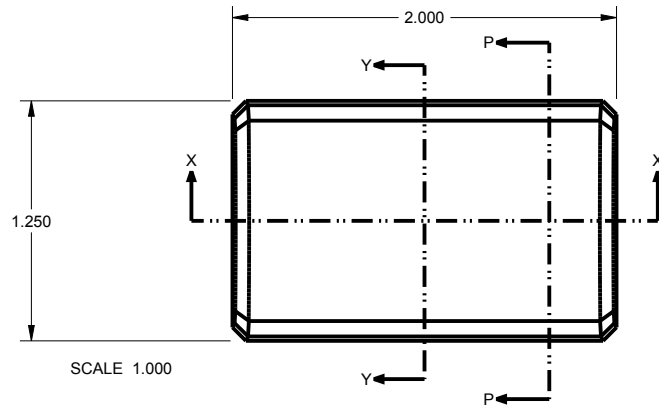

SCALE 1.000

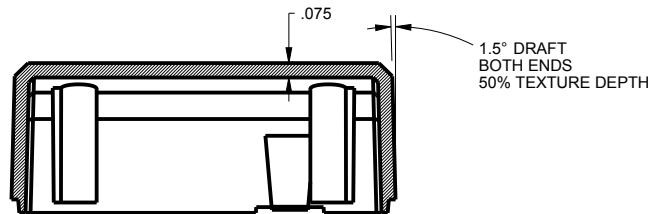

SECTION X-X

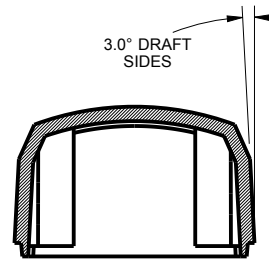
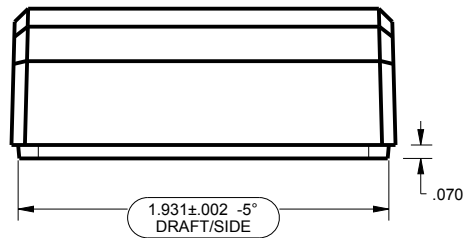

SECTION Y-Y

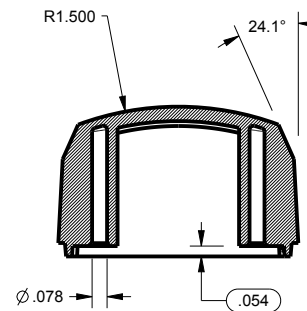

SECTION P-P

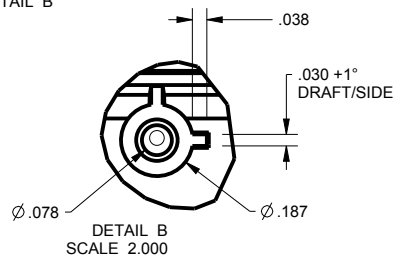
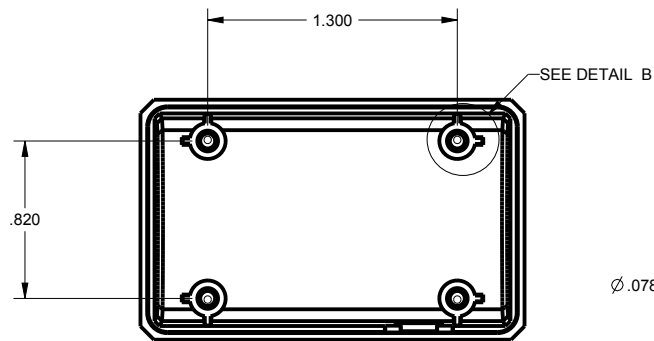
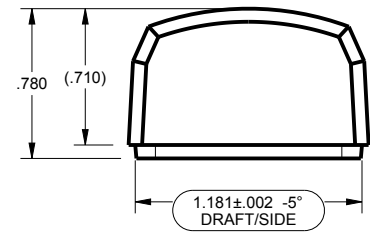

TOLERANCES: UNLESS OTHERWISE SPECIFIED DIMENSIONS ARE IN U.S. INCHES.

X.XX = .015 X.XXXX = .001  
X.XXX = .010 X.X° = 1°

NEW AGE ENCLOSURES

Customer's Part No: 201209

|          |           |      |
|----------|-----------|------|
| APPROVAL | BY        | DATE |
| CHECK    |           |      |
| ENG.     |           |      |
| SCALE    | AS NOTED  |      |
| DRAWN BY |           |      |
| M BOYER  | 15-Feb-13 |      |

**NEW AGE ENCLOSURES**

4330 Santa Fe Road San Luis Obispo, CA. 93401  
ph. (805) 595-1310 fax (805) 595-1024  
[www.newageenclosures.com](http://www.newageenclosures.com)

STANDARD - 2in DONGLE  
SXX-201209-XXX

|      |              |        |         |
|------|--------------|--------|---------|
| SIZE | DRAWING NAME | SHEET  | REV.DOC |
| A    | 201209_R1_0  | 3 OF 6 | 1.0     |

# 201209 BASE

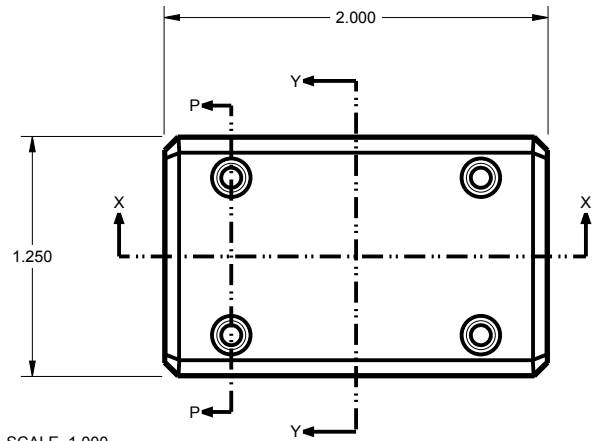

SCALE 1.000

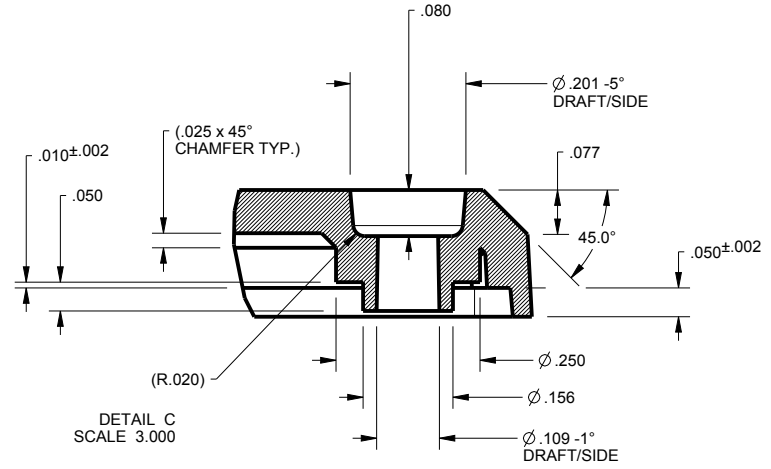

DETAIL C  
SCALE 3.000

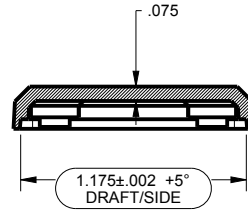
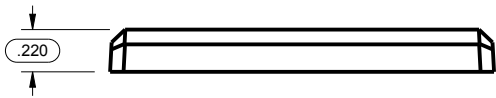
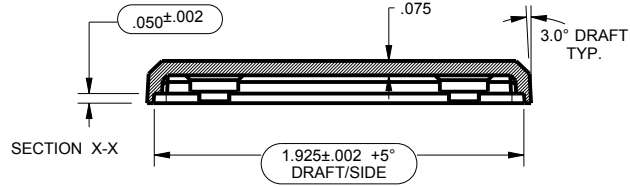

SECTION Y-Y

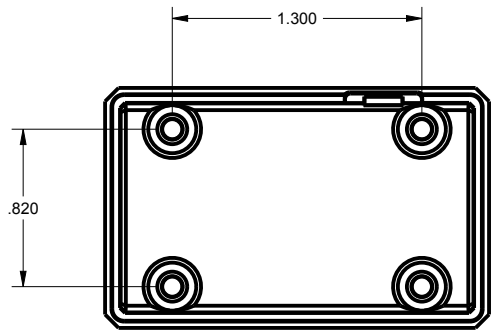
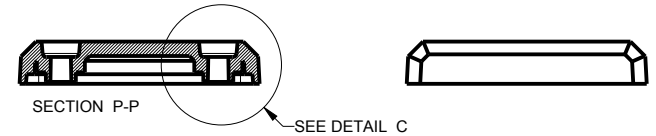

|   |           |  |         |
|---|-----------|--|---------|
| TOLERANCES: UNLESS OTHERWISE SPECIFIED<br>DIMENSIONS ARE IN U.S. INCHES.<br>X.XX = .015 X.XXXX = .001<br>X.XXX = .010 X.X° = 1° |           | <b>NEW AGE ENCLOSURES</b>  |         |
| NEW AGE ENCLOSURES  |           | 4330 Santa Fe Road San Luis Obispo, CA. 93401<br>ph. (805) 595-1310 fax (805) 595-1024<br><a href="http://www.newageenclosures.com">www.newageenclosures.com</a> |         |
| Customer's Part No: 201209  |           |  |         |
| APPROVAL  | BY        | DATE   |         |
| CHECK   |           |  |         |
| ENG.  |           |  |         |
| SCALE   | AS NOTED  |  |         |
| DRAWN BY  | SIZE      | DRAWING NAME   | SHEET   |
| M BOYER   | 15-Feb-13 | A 201209_R1_0  | 4 OF 6  |
|   |           |  | REV.DOC |
|   |           |  | 1.0     |

**STANDARD - 2in DONGLE**  
**SXX-201209-XXX**

# 201209 PCB

PCB SIZES ARE RECOMMENDATIONS ONLY. FINAL SIZES AND VERIFICATION OF IT'S FIT ARE THE SOLE RESPONSIBILITY OF THE OEM.

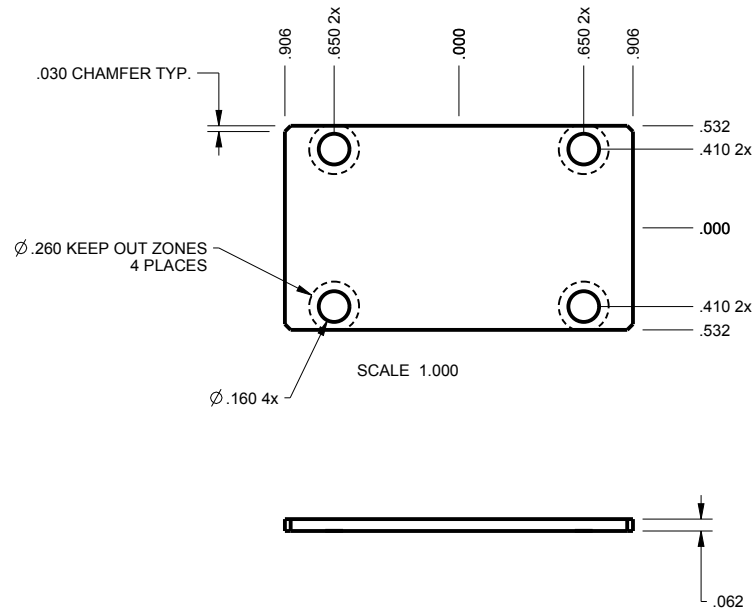

TOLERANCES: UNLESS OTHERWISE SPECIFIED  
DIMENSIONS ARE IN U.S. INCHES.  
X.XX = .015 X.XXXX = .001  
X.XXX = .010 X.X° = 1°

NEW AGE ENCLOSURES

Customer's Part No: 201209

|          |          |      |
|----------|----------|------|
| APPROVAL | BY       | DATE |
| CHECK    |          |      |
| ENG.     |          |      |
| SCALE    | AS NOTED |      |

|          |           |
|----------|-----------|
| DRAWN BY | 15-Feb-13 |
| M BOYER  |           |

## NEW AGE ENCLOSURES

4330 Santa Fe Road San Luis Obispo, CA. 93401  
ph. (805) 595-1310 fax (805) 595-1024  
[www.newageenclosures.com](http://www.newageenclosures.com)

STANDARD - 2in DONGLE  
SXX-201209-XXX

|      |              |
|------|--------------|
| SIZE | DRAWING NAME |
| A    | 201209_R1_0  |

|        |         |
|--------|---------|
| SHEET  | REV.DOC |
| 5 OF 6 | 1.0     |

## 201209 2nd OPERATION DETAILS

NEW AGE ENCLOSURES DELIVERS YOUR ENCLOSURE MARKET-READY WITH IN-HOUSE  
CNC MACHINING, PAD PRINTING, ASSEMBLY, AND FULFILLMENT.  
ALL SURFACES AND AREAS ARE AVAILABLE FOR CNC ALTERATION BY NEW AGE ENCLOSURES  
CALL (805) 595-1310 FOR PRICING AND SCHEDULE.  
THE INSIDE RADIUS OF ANY MACHINED FEATURES SHOULD BE NO SMALLER THAN .031"

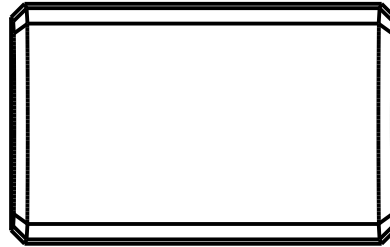

SCALE 1.000

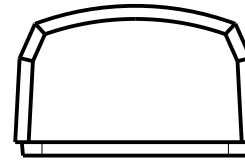
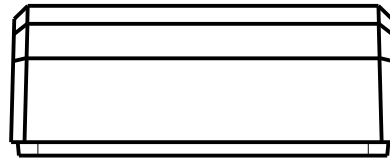
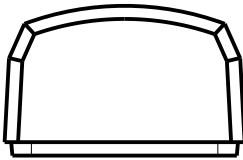

### SXX-201209-XXX COVER - ABS, BLACK

| STEP NO | DESCRIPTION | CUTTER        | FIXTURE | ORIENTATION | PROGRAM |
|---------|-------------|---------------|---------|-------------|---------|
|         |             | T2 = .062" EM |         |             |         |
|         |             | T2 = .062" EM |         |             |         |
|         |             | T2 = .062" EM |         |             |         |

TOLERANCES: UNLESS OTHERWISE SPECIFIED  
DIMENSIONS ARE IN U.S. INCHES.  
X.XX = .015 X.XXXX = .001  
X.XXX = .010 X.X° = 1°

**NEW AGE ENCLOSURES**

Customer's Part No: 201209

|          |           |      |
|----------|-----------|------|
| APPROVAL | BY        | DATE |
| CHECK    |           |      |
| ENG.     |           |      |
| SCALE    | AS NOTED  |      |
| DRAWN BY |           |      |
| M BOYER  | 15-Feb-13 |      |

## NEW AGE ENCLOSURES

4330 Santa Fe Road San Luis Obispo, CA. 93401  
ph. (805) 595-1310 fax (805) 595-1024  
[www.newageenclosures.com](http://www.newageenclosures.com)

### STANDARD - 2in DONGLE SXX-201209-XXX

|      |              |        |         |
|------|--------------|--------|---------|
| SIZE | DRAWING NAME | SHEET  | REV.DOC |
| A    | 201209_R1_0  | 6 OF 6 | 1.0     |



# Mouser Electronics

Authorized Distributor

Click to View Pricing, Inventory, Delivery & Lifecycle Information:

[New Age Enclosures:](#)

[S1A-201209](#) [S3A-201209](#)



Компания «ЭлектроПласт» предлагает заключение долгосрочных отношений при поставках импортных электронных компонентов на взаимовыгодных условиях!

Наши преимущества:

- Оперативные поставки широкого спектра электронных компонентов отечественного и импортного производства напрямую от производителей и с крупнейших мировых складов;
- Поставка более 17-ти миллионов наименований электронных компонентов;
- Поставка сложных, дефицитных, либо снятых с производства позиций;
- Оперативные сроки поставки под заказ (от 5 рабочих дней);
- Экспресс доставка в любую точку России;
- Техническая поддержка проекта, помощь в подборе аналогов, поставка прототипов;
- Система менеджмента качества сертифицирована по Международному стандарту ISO 9001;
- Лицензия ФСБ на осуществление работ с использованием сведений, составляющих государственную тайну;
- Поставка специализированных компонентов (Xilinx, Altera, Analog Devices, Intersil, Interpoint, Microsemi, Aeroflex, Peregrine, Syfer, Eurofarad, Texas Instrument, Miteq, Cobham, E2V, MA-COM, Hittite, Mini-Circuits, General Dynamics и др.);

Помимо этого, одним из направлений компании «ЭлектроПласт» является направление «Источники питания». Мы предлагаем Вам помощь Конструкторского отдела:

- Подбор оптимального решения, техническое обоснование при выборе компонента;
- Подбор аналогов;
- Консультации по применению компонента;
- Поставка образцов и прототипов;
- Техническая поддержка проекта;
- Защита от снятия компонента с производства.



#### Как с нами связаться

**Телефон:** 8 (812) 309 58 32 (многоканальный)

**Факс:** 8 (812) 320-02-42

**Электронная почта:** [org@eplast1.ru](mailto:org@eplast1.ru)

**Адрес:** 198099, г. Санкт-Петербург, ул. Калинина, дом 2, корпус 4, литера А.