



MAX9626 Evaluation Kit

General Description

The MAX9626 evaluation kit (EV kit) provides a proven design to evaluate the MAX9626 low-noise, low-distortion, and high-bandwidth differential amplifier/ADC driver in a 12-pin TQFN package. The EV kit circuit is preconfigured as an ADC driver. SMA connectors are provided for the board input/output and the EV kit operates off a single 2.85V to 5.25V power supply. The EV kit also evaluates the MAX9627/MAX9628. Request a free MAX9627/MAX9628 IC sample from the factory when ordering the EV kit.

Features

- ◆ 2.85V to 5.25V Single-Supply Range
- ◆ Factory-Set 1V/V Gain
- ◆ Adjustable-Output Common-Mode Voltage
- ◆ Shutdown Input
- ◆ Also Evaluates the MAX9627/MAX9628 (IC Replacement)
- ◆ Fully Assembled and Tested

Ordering Information

PART	TYPE
MAX9626EVKIT+	EV Kit

+Denotes lead(Pb)-free and RoHS compliant.

Component List

DESIGNATION	QTY	DESCRIPTION
C1, C6	2	1000pF \pm 10%, 50V X7R ceramic capacitors (0402) Murata GRM155R71H102K TDK C1005X7R1H102K
C2, C3, C4, C8	4	0.1 μ F \pm 10%, 10V X5R ceramic capacitors (0402) Murata GRM155R61A104K TDK C1005X5R1A104K
C5, C7	2	10 μ F \pm 10%, 10V tantalum capacitors (A case) AVX TAJA106K010R Vishay/Sprague 595D106X9010A2T
IN+, IN-, OUT+, OUT-, VOVM	5	Edge-mount receptacle SMA connectors
JU1	1	2-pin header
R1, R2, R17	3	0 Ω resistors (0402)

DESIGNATION	QTY	DESCRIPTION
R3, R4, R14, R15, R16	0	Not installed, resistors (0402)
R5	1	100k Ω \pm 5% resistor (0402)
R6, R7	2	64.9 Ω \pm 1% resistors (0402)
R8, R9	2	100 Ω \pm 1% resistors (0402)
R10, R11	2	10k Ω \pm 1% resistors (0402)
R12, R13	2	249 Ω \pm 1% resistors (0402)
SHDB, TP1, TP2, TP3	4	Test points
T1	1	Surface-mount RF transformer Coilcraft Z9314-AL
U1	1	Low-noise differential amplifier (12 TQFN) Maxim MAX9626ATC+
—	1	Shunts
—	1	PCB: MAX9626/27/28 EVALUATION KIT+

Component Suppliers

SUPPLIER	PHONE	WEBSITE
AVX Corporation	843-946-0238	www.avxcorp.com
Coilcraft, Inc.	847-639-6400	www.coilcraft.com
Murata Electronics North America, Inc.	770-436-1300	www.murata-northamerica.com
TDK Corp.	847-803-6100	www.component.tdk.com
Vishay	402-563-6866	www.vishay.com

Note: Indicate that you are using the MAX9626 when contacting these component suppliers.



MAX9626 Evaluation Kit

Quick Start

Required Equipment

- MAX9626 EV kit
- 2.85V to 5.25V, 100mA DC power supply (VCC)
- Oscilloscope
- Signal generator

Procedure

The EV kit is fully assembled and tested. Follow the steps below to verify board operation. **Caution: Do not turn on the power supply until all connections are completed.**

- 1) This circuit requires a supply voltage of 2.85V to 5.25V. For evaluation purposes, connect a 5V supply to the VCC PCB pad.
- 2) Connect the power-supply ground to the GND PCB pad.
- 3) Connect the OUT+ SMA connector to the oscilloscope.
- 4) Turn on the power supply.
- 5) Apply a signal at the IN+ and IN- SMA connectors.
- 6) Verify the output signal on the oscilloscope.

Table 1. JU1 Jumper Selection

SHUNT POSITION	SHDB PIN	EV KIT FUNCTION
Installed	Connected to GND	Disabled
Not installed*	Connected to VCC through R5	Enabled

*Default position.

Detailed Description of Hardware

Input/Output

The MAX9626 EV kit provides SMA connectors at the inputs to accept differential signals at IN+ and IN-. At the output, SMA connectors OUT+ and OUT- are provided to monitor the output signal. By default, OUT- is connected to GND through resistor R17.

Input Termination Resistors

The EV kit provides placeholders (R3 and R4) to terminate IN+ and IN-, respectively. Install resistors on R3 and R4 if input termination is required. When internal terminations are used, remove external termination resistors R6 and R7.

Shutdown Mode (SHDB)

Jumper JU1 controls the shutdown mode (SHDB) of the device. When SHDB is pulled low, the device is disabled. When the SHDB pin is pulled high, the device is enabled. See Table 1 for JU1 jumper selection.

Output Common-Mode Voltage (VOCM)

The output common mode can be easily set by applying a voltage at the VOCM input PCB pad on the EV kit, thus eliminating the need for a coupling transformer or AC-coupling capacitors. An SMA connector is also provided at VOCM to allow a high-frequency signal to characterize the bandwidth of the VOCM path. In this case, a resistor must be installed at R16 and capacitors C3, C6, and C7 should be removed.

MAX9626 Evaluation Kit

Evaluates: MAX9626/MAX9627/MAX9628

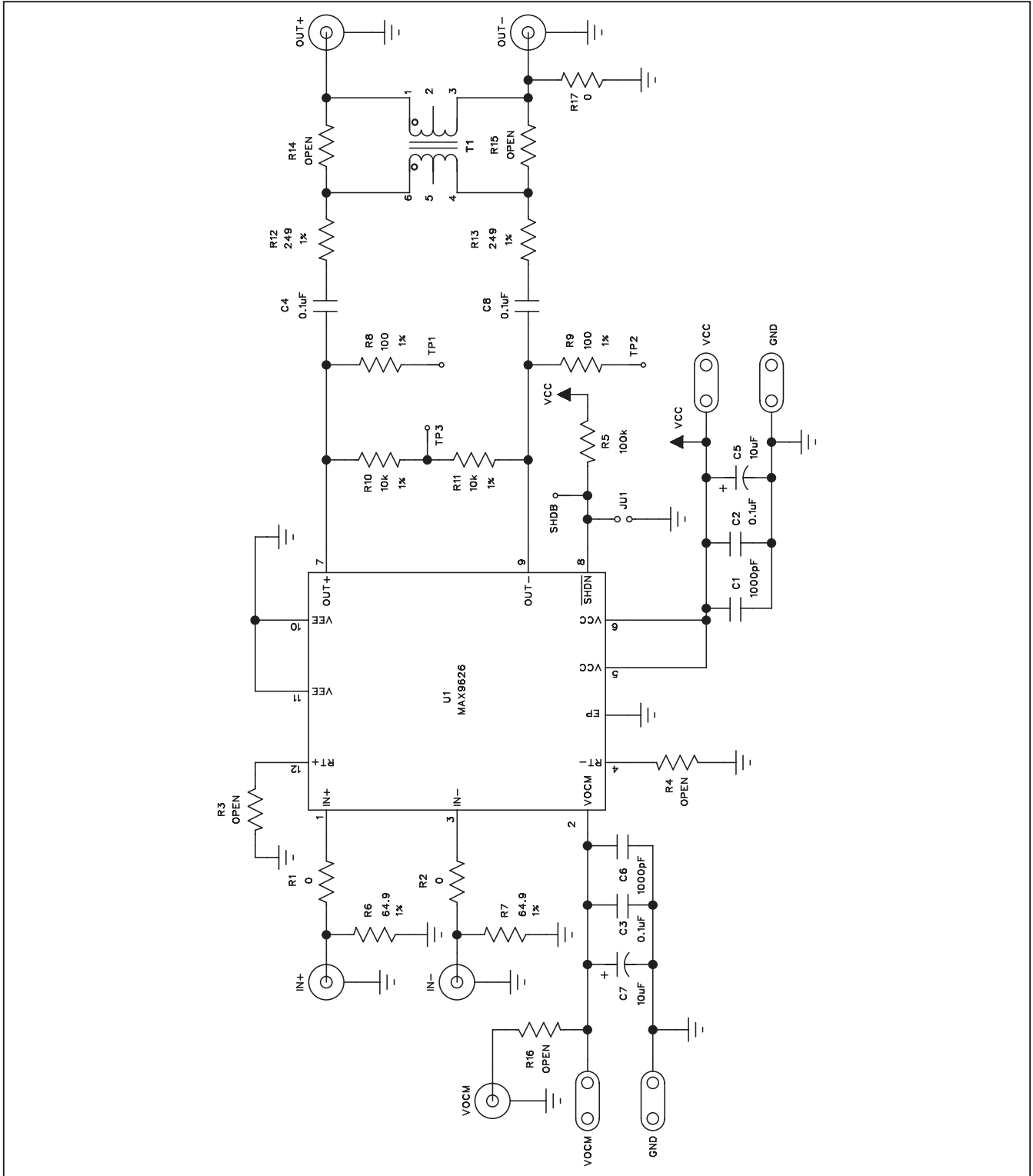

Figure 1. MAX9626 EV Kit Schematic

MAX9626 Evaluation Kit

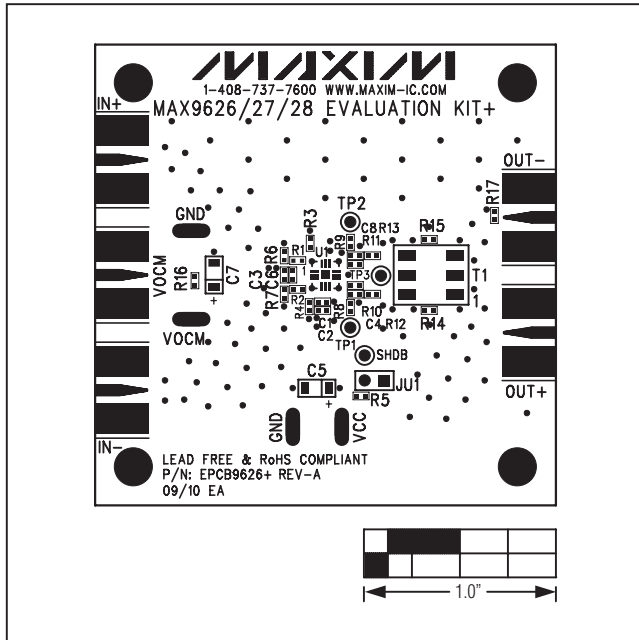

Figure 2. MAX9626 EV Kit Component Placement Guide—Component Side

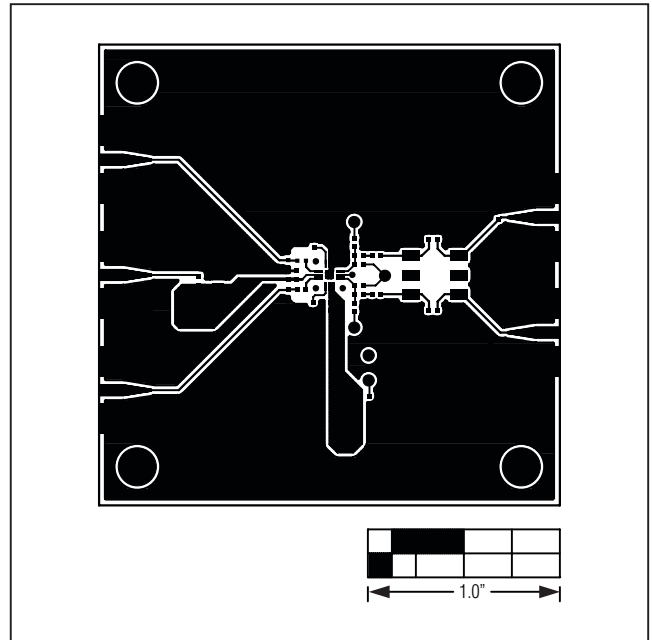

Figure 3. MAX9626 EV Kit PCB Layout—Component Side

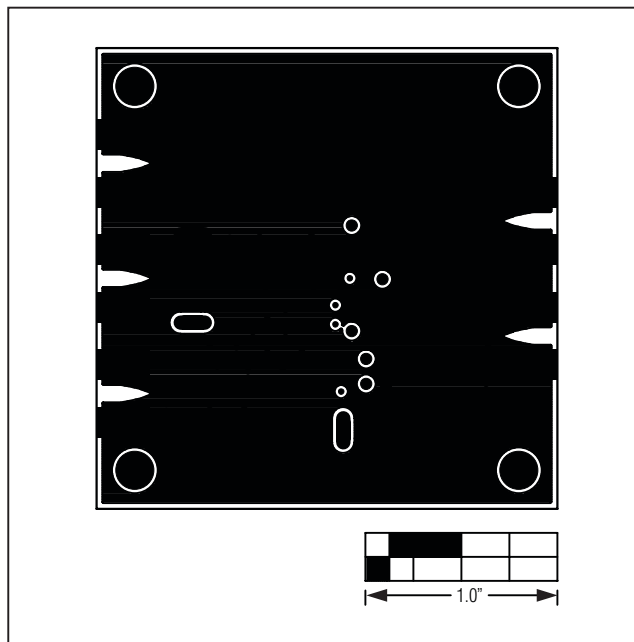

Figure 4. MAX9626 EV Kit PCB Layout—Internal Layer 2 (GND)

MAX9626 Evaluation Kit

Evaluates: MAX9626/MAX9627/MAX9628

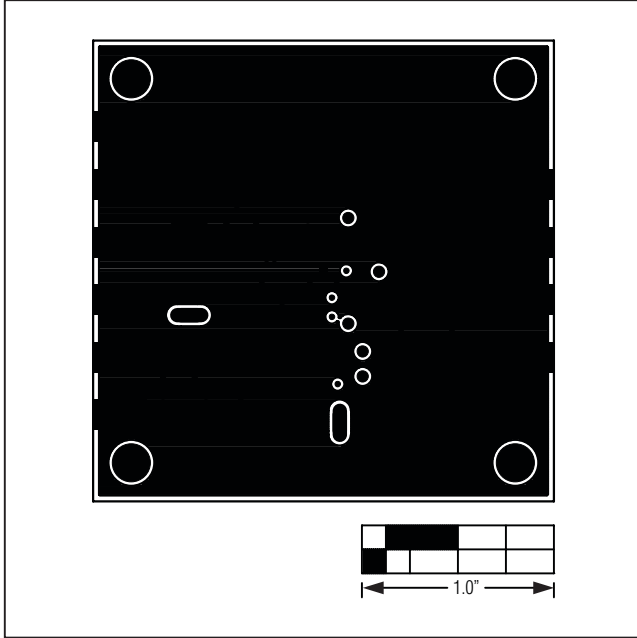

Figure 5. MAX9626 EV Kit PCB Layout—Internal Layer 3 (GND)

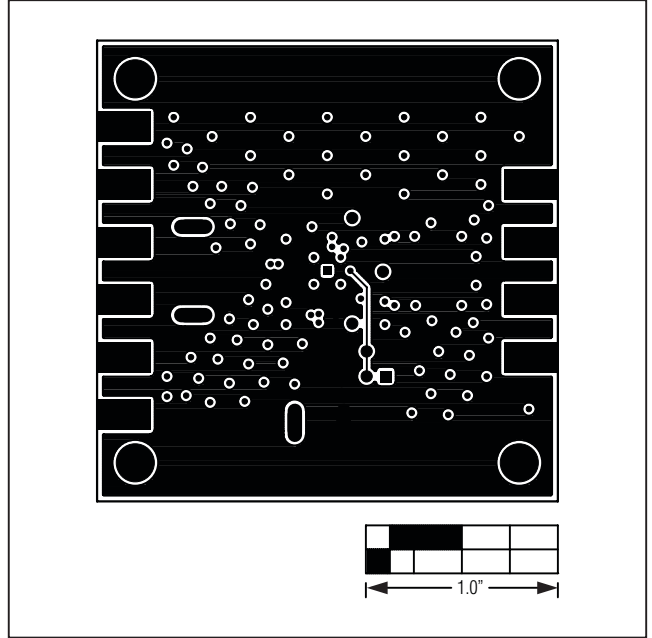

Figure 6. MAX9626 EV Kit PCB Layout—Solder Side

MAX9626 Evaluation Kit

Evaluates: MAX9626/MAX9627/MAX9628

Revision History

REVISION NUMBER	REVISION DATE	DESCRIPTION	PAGES CHANGED
0	10/10	Initial release	—

Maxim cannot assume responsibility for use of any circuitry other than circuitry entirely embodied in a Maxim product. No circuit patent licenses are implied. Maxim reserves the right to change the circuitry and specifications without notice at any time.

6 _____ **Maxim Integrated Products, 120 San Gabriel Drive, Sunnyvale, CA 94086 408-737-7600**

© 2010 Maxim Integrated Products

Maxim is a registered trademark of Maxim Integrated Products, Inc.



Компания «ЭлектроПласт» предлагает заключение долгосрочных отношений при поставках импортных электронных компонентов на взаимовыгодных условиях!

Наши преимущества:

- Оперативные поставки широкого спектра электронных компонентов отечественного и импортного производства напрямую от производителей и с крупнейших мировых складов;
- Поставка более 17-ти миллионов наименований электронных компонентов;
- Поставка сложных, дефицитных, либо снятых с производства позиций;
- Оперативные сроки поставки под заказ (от 5 рабочих дней);
- Экспресс доставка в любую точку России;
- Техническая поддержка проекта, помощь в подборе аналогов, поставка прототипов;
- Система менеджмента качества сертифицирована по Международному стандарту ISO 9001;
- Лицензия ФСБ на осуществление работ с использованием сведений, составляющих государственную тайну;
- Поставка специализированных компонентов (Xilinx, Altera, Analog Devices, Intersil, Interpoint, Microsemi, Aeroflex, Peregrine, Syfer, Eurofarad, Texas Instrument, Miteq, Cobham, E2V, MA-COM, Hittite, Mini-Circuits, General Dynamics и др.);

Помимо этого, одним из направлений компании «ЭлектроПласт» является направление «Источники питания». Мы предлагаем Вам помощь Конструкторского отдела:

- Подбор оптимального решения, техническое обоснование при выборе компонента;
- Подбор аналогов;
- Консультации по применению компонента;
- Поставка образцов и прототипов;
- Техническая поддержка проекта;
- Защита от снятия компонента с производства.



Как с нами связаться

Телефон: 8 (812) 309 58 32 (многоканальный)

Факс: 8 (812) 320-02-42

Электронная почта: org@eplast1.ru

Адрес: 198099, г. Санкт-Петербург, ул. Калинина, дом 2, корпус 4, литера А.