

Connectivity....for  
Business-Critical Continuity

# Type N Connectors

Product Catalog



**JOHNSON**<sup>®</sup>

  
**EMERSON**<sup>™</sup>  
Network Power

**Johnson® Type N Connectors** meet or exceed the performance requirements of MIL-PRF-39012. All designs are based on 50 ohm system impedance per MIL-STD-348, and operate at frequencies up to 11 GHz minimum.

## Applications

- Antennas
- Base stations
- Broadcast
- Cable assemblies
- Cellular
- Instrumentation
- Microwave Radio
- PCS
- Radar
- Radios
- RF and Microwave Components
- Satcom
- Surge Protection
- WLAN

## Features

- All contacts are plated with 50 micro-inches of Gold for excellent durability and high frequency performance
- Brass bodies are offered with Tri-alloy plating as the standard finish, and Gold where soldering is required
- Coupling nuts are hex shaped to allow the connectors to be tightened to specified mating torque
- Plug interfaces and bulkhead jack bodies include gaskets for environmental sealing
- Precision grade in-series adapters have very low return loss performance to 18 GHz
- Cabled contacts are captivated upon assembly
- Flexible cable contacts can be crimped or soldered
- Semi-rigid cabled connectors are capable of operation to 18 GHz
- Semi-rigid cabled plug connectors are available in one piece versions, requiring solder attachment only between the cable jacket and connector body

## Table of Contents

	PAGE
ASSEMBLY INSTRUCTIONS .....	13
ASSEMBLY TOOLS .....	11
COMPETITOR CROSS REFERENCE .....	23
ELECTRICAL SPECIFICATIONS .....	3-4
ENVIRONMENTAL SPECIFICATIONS .....	5
FLEXIBLE CABLE CONNECTORS .....	8
IN-SERIES ADAPTERS .....	10
JACK RECEPTACLES .....	9
MATERIAL SPECIFICATIONS .....	5
MECHANICAL SPECIFICATIONS .....	5
MOUNTING HOLES .....	6
SEMI-RIGID CABLED CONNECTORS .....	7

## ELECTRICAL SPECIFICATIONS

**Impedance:** 50 Ohms

**Frequency Range:**

Flexible Cabled and Receptacles .....	0-11 GHz
Semi-Rigid Cabled and Adapters .....	0-18 GHz

**VSWR:** (f = GHz)

Straight Flexible Cabled .....		<u>0-11 GHz</u> 1.30 Max
Right Angle Flexible Cabled .....	<u>0-9 GHz</u> 1.35 MAX	<u>9-11 GHz</u> 1.50 Max
RG-405 Semi-Rigid Plugs .....	<u>0-11 GHz</u> 1.07+.01f	<u>11-18 GHz</u> <1.25 Typical
RG-402 Semi-Rigid Plugs .....	1.05+.01f	<1.25 Typical
RG-401 Semi-Rigid Plugs .....	1.06+.01f	<1.25 Typical
RG-405 Semi-Rigid Jacks .....	1.15+.02f	<1.50 Typical
RG-402 Semi-Rigid Jacks .....	1.10+.02f	<1.50 Typical
RG-401 Semi-Rigid Jacks .....	1.10+.02f	<1.50 Typical
Adapters .....		<u>0-18 GHz</u> 1.05+.01f
Un-cabled Receptacles .....		N/A

**Insertion Loss:** (dB, tested at 9 GHz)

Straight Flexible Cabled .....	0.15 Max
Right Angle Flexible Cabled .....	0.30 Max
Semi-Rigid Cabled and Adapters .....	$0.05\sqrt{f}$ (GHz)
Un-cabled Receptacles .....	N/A

**Working Voltage:** (Vrms maximum)

	<u>Sea Level</u>	<u>70K Feet</u>
RG-316, 316DS Cabled .....	250	65
RG-58, 142, 405 Cabled .....	335	85
RG-402 Cabled .....	500	125
RG-213, 214, 401, LMR-400 Cabled .....	1000	250
Un-cabled Receptacles and Adapters .....	1000	250

**Dielectric Withstanding Voltage:** (Vrms minimum)

	<u>Sea Level</u>
RG-316, 316DS Cabled .....	750
RG-58, 142, 405 Cabled .....	1000
RG-402 Cabled .....	1500
RG-213, 214, 401, LMR-400 Cabled .....	2500
Un-cabled Receptacles and Adapters .....	2500

**Corona Level:** (Volts minimum)

	<u>70K Feet</u>
RG-316, 316DS Cabled .....	190
RG-58, 142, 405 Cabled .....	250
RG-402 Cabled .....	375
RG-213, 214, 401, LMR-400 Cabled and Adapters .....	500
Un-cabled Receptacles .....	N/A

## ELECTRICAL SPECIFICATIONS cont'd

**RF High Potential Withstanding Voltage:** (Vrms minimum, tested at 4 and 7 MHz)

RG-316, 316DS Cabled .....	500
RG-58, 142, 405 Cabled .....	670
RG-402 Cabled .....	1000
RG-213, 214, 401, LMR-400 Cabled .....	1500
Un-cabled Receptacles and Adapters .....	1500

**Insulation Resistance:** 5000 Megohms minimum

**Contact Resistance:** (milliohms maximum)

	<u>Initial</u>	<u>After Environmental</u>
Center Contact		
Straight Cabled (non-captivated) .....	1.0	1.5
Straight Cabled (captivated) .....	2.5	3.0
Right Angle Cabled .....	2.5	3.0
Un-cabled Receptacles and Adapters .....	1.0	1.5
Outer Contact .....	0.2	N/A
Braid to Body (Flexible Cabled Only) .....	0.05	N/A

**RF Leakage:** (dB minimum, tested at 2.5 GHz)

Cabled Connectors and Adapters .....	-90
Un-cabled Receptacles .....	N/A

**IMP3:** Typically <-90 dBm (tested per IEC Guidelines using 20W inputs swept over 1930-1990 MHz)



## MECHANICAL SPECIFICATIONS

**Engagement Design:** MIL-STD-348A, Series N  
**Durability:** 500 Cycles minimum  
**Engagement/Disengagement Force:** 6 inch-pounds maximum  
**Mating Torque:** 7 to 10 inch-pounds  
**Bulkhead Mounting Nut Torque:** 15 inch-pounds recommended  
**Coupling Proof Torque:** 15 inch-pounds minimum  
**Coupling Nut Retention:** 100 pounds minimum  
**Contact Retention:** (minimum - captivated contacts only)

	<u>Axial Force (lbs)</u>	<u>Torque (in-oz)</u>
Cabled Connectors and Adapters .....	6	N/A
Un-cabled Receptacles .....	6	4

**Cable Retention: (minimum\*)**

	<u>Axial Force (lbs)</u>	<u>Torque (in-oz)</u>
RG-316 Cabled .....	20	N/A
RG-316DS Cabled .....	30	N/A
RG-58 Cabled .....	40	N/A
RG-142 Cabled .....	45	N/A
RG-213, 214 and LMR-400 Cabled .....	90	N/A
RG-405 Cabled .....	30	16
RG-402 Cabled .....	60	55
RG-401 Cabled .....	90	80

\* Or cable breaking strength, whichever is less

## ENVIRONMENTAL SPECIFICATIONS

(Meets or Exceeds the Applicable Paragraph of MIL-PRF-39012)

**Temperature Range:** -65°C to +165°C  
**Thermal Shock:** MIL-STD-202, Method 107, Condition B (except +85°C high temperature)  
**Corrosion:** MIL-STD-202, Method 101, Condition B  
**Shock:** MIL-STD-202, Method 213, Condition I  
**Vibration:** MIL-STD-202, Method 204, Condition B  
**Moisture Resistance:** MIL-STD-202, Method 106

## MATERIAL SPECIFICATIONS

**Bodies:** Crimp - Brass per ASTM B16, Tri-Alloy (Cu/Sn/Zn) plated (.0001" min)  
 Solder - Brass per ASTM B16, Gold plated\* per MIL-G-45204 (.00001" min)  
 Adapter - Brass per ASTM B16, Tri-Alloy (Cu/Sn/Zn) or Nickel per QQ-N-290 plated (.0001" min)  
**Contacts:** Male - Brass per ASTM B16, Gold plated\* per MIL-G-45204 (.00005" min)  
 Female - Beryllium Copper per ASTM B196, Gold plated\* per MIL-G-45204 (.00005" min)  
 Adapter - Beryllium Copper per ASTM B196, Gold plated\* per MIL-G-45204 (.00005" min)  
**Insulators:** PTFE Fluorocarbon per ASTM D1710 and ASTM D1457  
**Gaskets:** Silicon Rubber per ZZ-R-765  
**Crimp Sleeves:** Copper per ASTM A75, Tri-Alloy (Cu/Sn/Zn) plated (.0001" min)  
**End Caps:** Brass per ASTM B16, Tri-Alloy (Cu/Sn/Zn) plated (.0001" min)  
**Nut Retention Spring (Plugs):** Beryllium Copper per ASTM B196, un-plated  
**Mounting Nut (Bulkhead Jacks):** Brass per ASTM B16, Nickel plated per QQ-N-290 (.0001" min)  
**Lock Washer (Bulkhead Jacks):** Steel, Zinc plated (.0001" min)

\* All Gold plated parts include a .00005" minimum Nickel under plated barrier layer

## MATING ENGAGEMENT FOR TYPE N SERIES PER MIL-STD-348A



- NOTES:
1. THIS INTERFACE SHALL MEET THE GAUGE REQUIREMENTS AS SPECIFIED IN MIL-PRF-39012/1G AND /2G.
  2. CLEARANCE FOR MATING CONNECTOR COUPLING NUT.

## MOUNTING HOLES



Fig 1



Fig 2

## Straight Solder Type Plug – With Solder Contact



Cable Type	VSWR & Freq. Range	Gold Plated
RG-405, .086 Semi-Rigid	1.07+.01f (GHz), 0-11 GHz <1.25 Typical, 11-18 GHz	138-4693-001*
RG-402, .141 Semi-Rigid	1.05+.01f (GHz), 0-11 GHz <1.25 Typical, 11-18 GHz	138-4694-001*
RG-401, .250 Semi-Rigid	1.06+.01f (GHz), 0-11 GHz <1.25 Typical, 11-18 GHz	138-4696-001*

\* Tri-Alloy plated coupling nut

## Straight Solder Type Plug – Captivated Solderless Contact



Cable Type	VSWR & Freq. Range	Gold Plated
RG-405, .086 Semi-Rigid	1.07+.01f (GHz), 0-11 GHz <1.25 Typical, 11-18 GHz	138-4693-011*
RG-402, .141 Semi-Rigid	1.05+.01f (GHz), 0-11 GHz <1.25 Typical, 11-18 GHz	138-4694-011*
RG-401, .250 Semi-Rigid	1.06+.01f (GHz), 0-11 GHz <1.25 Typical, 11-18 GHz	138-4696-011*

\* Tri-Alloy plated coupling nut

## Straight Solder Type Bulkhead Jack – With Solder Contact

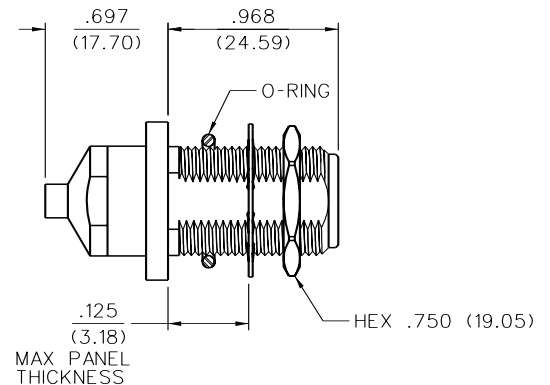

Cable Type	VSWR & Freq. Range	Gold Plated
RG-405, .086 Semi-Rigid	1.15+.02f (GHz), 0-11 GHz <1.50 Typical, 11-18 GHz	138-4593-401*
RG-402, .141 Semi-Rigid	1.10+.02f (GHz), 0-11 GHz <1.50 Typical, 11-18 GHz	138-4594-401*
RG-401, .250 Semi-Rigid	1.10+.02f (GHz), 0-11 GHz <1.50 Typical, 11-18 GHz	138-4596-401*

\* Tri-Alloy plated bulkhead jack body  
Mounting hole layout figure 1 on page 6

## Straight Crimp Type Plug – Solder or Crimp Contact

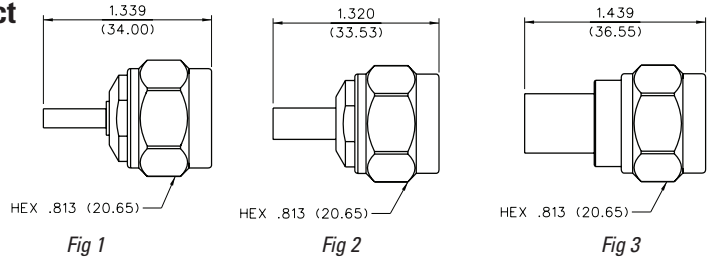

Cable Type	VSWR & Freq. Range	Tri-Alloy Plated	Figure
RG-161/U, 174, 188, 316	1.30 Max, 0-11 GHz	138-4403-007	1
RG-188 DS, RG-316 DS	1.30 Max, 0-11 GHz	138-4404-007	1
RG-58/U, 141, 303	1.30 Max, 0-11 GHz	138-4407-007	2
RG-55/U, 142, 223, 400	1.30 Max, 0-11 GHz	138-4408-007	2
RG-8/U, 213	1.30 Max, 0-11 GHz	138-4416-007	3
RG-9/U, 214	1.30 Max, 0-11 GHz	138-4418-007	3
LMR-400, BELDEN 9913	1.30 Max, 0-11 GHz	138-4449-007	3

## Right Angle Crimp Type Plug – Captivated Contact

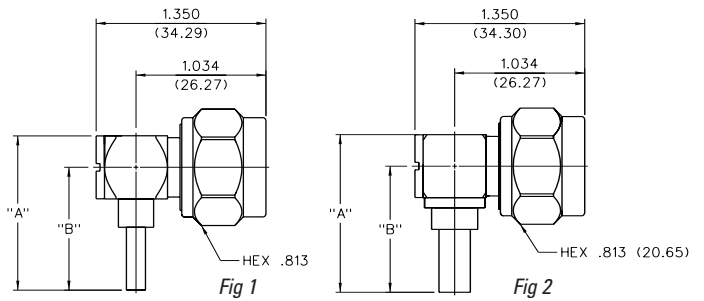
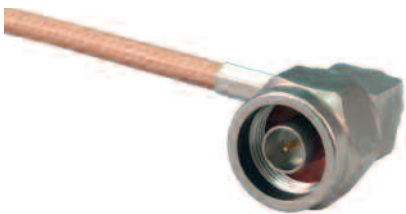

Cable Type	VSWR & Freq. Range	Tri-Alloy Plated	Figure	"A"	"B"
RG-161/U, 174, 188, 316	1.35 Max, 0-9 GHz 1.50 Max, 9-11 GHz	138-4403-107	1	1.227 (31.17)	.977 (24.82)
RG-188 DS, RG-316 DS	1.35 Max, 0-9 GHz 1.50 Max, 9-11 GHz	138-4404-107	1	1.227 (31.17)	.977 (24.82)
RG-58/U, 141, 303	1.35 Max, 0-9 GHz 1.50 Max, 9-11 GHz	138-4407-107	2	1.253 (31.83)	1.003 (25.48)
RG-55/U, 142, 223, 400	1.35 Max, 0-9 GHz 1.50 Max, 9-11 GHz	138-4408-107	2	1.253 (31.83)	1.003 (25.48)
RG-8/U, 213	1.35 Max, 0-9 GHz 1.50 Max, 9-11 GHz	138-4416-107	2	1.365 (34.67)	1.115 (28.32)
RG-9/U, 214	1.35 Max, 0-9 GHz 1.50 Max, 9-11 GHz	138-4418-107	2	1.365 (34.67)	1.115 (28.32)

## Straight Crimp Type Bulkhead Jack – Solder or Crimp Contact

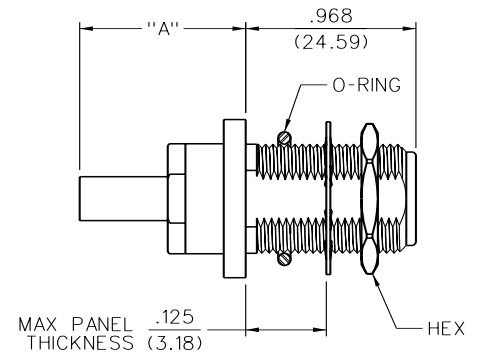

Cable Type	VSWR & Freq. Range	Tri-Alloy Plated	"A"
RG-161/U, 174, 188, 316	1.30 Max, 0-11 GHz	138-4303-407	.943 (23.95)
RG-188 DS, RG-316 DS	1.30 Max, 0-11 GHz	138-4304-407	.943 (23.95)
RG-58/U, 141, 303	1.30 Max, 0-11 GHz	138-4307-407	.943 (23.95)
RG-55/U, 142, 223, 400	1.30 Max, 0-11 GHz	138-4308-407	.943 (23.95)
RG-8/U, 213	1.30 Max, 0-11 GHz	138-4316-407	.997 (25.32)
RG-9/U, 214	1.30 Max, 0-11 GHz	138-4318-407	.997 (25.32)
LMR-400, BELDEN 9913	1.30 Max, 0-11 GHz	138-4349-407	.997 (25.32)

Mounting hole layout figure 1 on page 6



**Rear Mount Bulkhead Jack Receptacle**



Freq. Range	Tri-Alloy Plated
0-11 GHz	138-4701-407

Mounting hole layout figure 1 on page 6

**4-Hole Flange Mount Jack Receptacle – Flush Dielectric**



Freq. Range	Tri-Alloy Plated
0-11 GHz	138-4701-607

Mounting hole layout figure 2 on page 6

## Jack to Jack Adapter

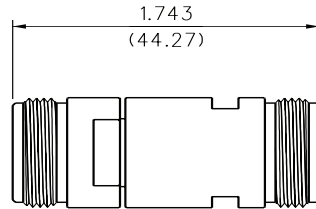

<b>VSWR &amp; Freq. Range</b>	<b>Tri-Alloy Plated</b>
1.05+.01f (GHz), 0-18 GHz	138-4901-807

## Jack to Bulkhead Jack Adapter

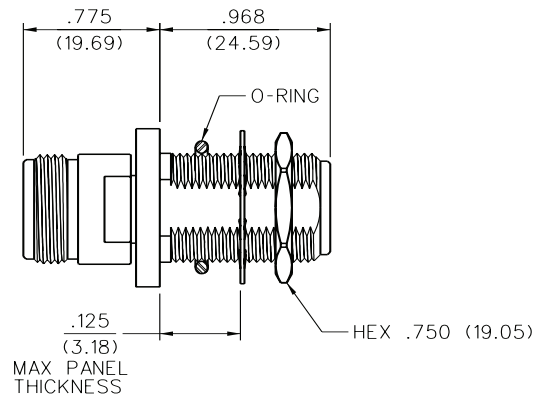

<b>VSWR &amp; Freq. Range</b>	<b>Tri-Alloy Plated</b>
1.05+.01f (GHz), 0-18 GHz	138-4901-407

Mounting hole layout figure 1 on page 6

## Plug to Plug Adapter

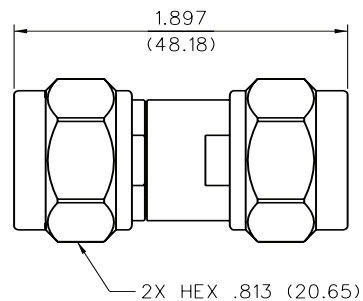

<b>VSWR &amp; Freq. Range</b>	<b>Tri-Alloy Plated</b>
1.05+.01f (GHz), 0-18 GHz	138-4901-817

## ASSEMBLY TOOLS

### Precision Ergonomic Hand Crimp Tool

Hand crimp tool and die sets include all hex sizes necessary for Type N connector applications. Ratchet tool action insures a complete crimp every time.



Part No.	Description	Hex	Width
140-0000-967	Ergonomic Hand Crimp Tool Frame Only <ul style="list-style-type: none"> <li>• Longer handles for leverage</li> <li>• Padded and contoured to fit in hand</li> <li>• Precision ground die sets</li> <li>• 50,000 cycle lifespan frame</li> </ul>		
140-0000-990	Die set for RG-316, 316 DS, 58, 142	.068 (1.73)	.090 (2.29)
		.128 (3.25)	.475 (12.07)
		.151 (3.83)	.475 (12.07)
		.213 (5.41)	.475 (12.07)
140-0000-991	Die set for RG-213, 214, LMR-4000	.111 (2.82)	.090 (2.29)
		.116 (2.95)	.090 (2.29)
		.429 (10.90)	.475 (12.07)

### Contact Hand Crimp Tool

The micro contact crimp tool provides an accurate eight indent crimp on small diameter contacts. This crimp tool is used with the 140-0000-971 Variable Positioner. Set the crimp size in the adjustment window and position the variable locator to obtain an accurate repeatable crimp on the contact.



Part No.	Description	ASTRO Tool Part No.
140-0000-970	Frame Only	612118-1
140-0000-971	Positioner	N/A

## Semi-Rigid Assembly Tools

Accurate assembly of the Semi-Rigid Cabled Connectors is obtained with the tools listed below. Industry standard devices are used if possible for customer convenience and tool compatibility.



Item	Part No.	Description
A	140-0000-962	Soldering Vise (does not include inserts (B) or stop screws (F),(G))
B	140-0000-964	Semi-Rigid Cable Clamp Inserts for .086" OD Cable
	140-0000-965	Semi-Rigid Cable Clamp Inserts for .141" OD Cable
	140-0000-986	Semi-Rigid Cable Clamp Inserts for .250" OD Cable
C	140-0000-983	Location Fixture for Type N Plug Connectors
D	140-0000-984	Solder Shim for .086" & .141" OD Cable
	140-0000-985	Solder Shim for .250" OD Cable
E	140-0000-987	Location Fixture for .086" OD Cable
	140-0000-988	Location Fixture for .141" OD Cable
	140-0000-989	Location Fixture for .250" OD Cable
F	140-0000-981	Stop Screw for Semi-Rigid Type N Plugs
G	140-0000-972	Stop Screw for Semi-Rigid Type N Jacks

## ASSEMBLY INSTRUCTIONS

### Type N Straight Plug Crimp Style for RG-316 and 316DS Flexible Cable

- 1 Identify connector parts (3 piece parts).
- 2 Strip cable to dimensions shown. Do not nick center conductor. A wire stripper of correct size is recommended for this step. Tin center conductor if contact will be solder attached. Do not tin center conductor if contact will be crimp attached. Slide crimp sleeve onto jacket of cable.
3. Assemble rear contact onto cable as shown Rear contact should butt against cable dielectric during attachment.  
**Solder Attachment:** Solder rear contact to center conductor through solder hole using .020 (.051) diameter flux core solder wire. Use a minimum amount of solder for a good joint.  
**Crimp Attachment:** Crimp rear contact to center conductor using Johnson indent hand tool 140-0000-970. Crimp location should be centered between end of rear contact and solder hole using positioning tool 140-0000-971. Crimp attachment to solid center conductor cables is not recommended.
4. Flare braid and slide plug connector assembly over rear contact and under braid. Rear contact must engage fully with internal captivated plug contact. Cable jacket should be located near end of crimp stem when contacts are fully engaged.
5. Arrange braid uniformly around crimp stem. Slide crimp sleeve forward and crimp using Johnson ergonomic hand crimp frame 140-0000-967 with recommended hex size die set. Maintain forward pressure on cable while crimping.

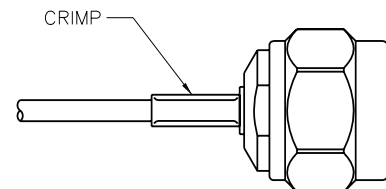

Cable Group	Part No.	Crimp Sleeve Hex Size	Contact Crimp
RG-316/U, 161, 174, 188	138-4403-007	.128 (3.25)	8 INDENT
RG-316 DS, 188 DS	138-4404-007	.151 (3.84)	8 INDENT

Tool	Assembly
	138-4403/4404-007
Crimp Frame	140-0000-967
Die Set	140-0000-990
Contact Tool	140-0000-970
Positioner	140-0000-971

## Type N Straight Plug Crimp Style for RG-58, 142, 213, 214 and LMR-400 Flexible Cable

1. Identify connector parts (3 piece parts).
2. Strip cable to dimensions shown. Do not nick center conductor. A wire stripper of correct size is recommended for this step. Tin center conductor if contact will be solder attached. Do not tin center conductor if contact will be crimp attached. Slide crimp sleeve onto jacket of cable.
3. Assemble plug contact onto cable as shown. Plug contact should butt against cable dielectric during attachment.
 

**Solder Attachment:** Solder plug contact to center conductor through solder hole using .020 (.051) diameter flux core solder wire. Use a minimum amount of solder for a good joint.

**Crimp Attachment:** Crimp plug contact to center conductor using Johnson ergonomic hand crimp frame 140-0000-967 with recommended hex size die set. Crimp location should be on end of plug contact next to cable dielectric. Crimp attachment to solid center conductor cables is not recommended.
4. Flare braid and slide plug connector assembly over plug contact and under braid. Seat plug connector assembly firmly onto contact. Arrange braid uniformly around crimp stem. Slide crimp sleeve forward and crimp using Johnson ergonomic hand crimp frame 140-0000-967 with recommended hex size die set. Maintain forward pressure on cable while crimping.

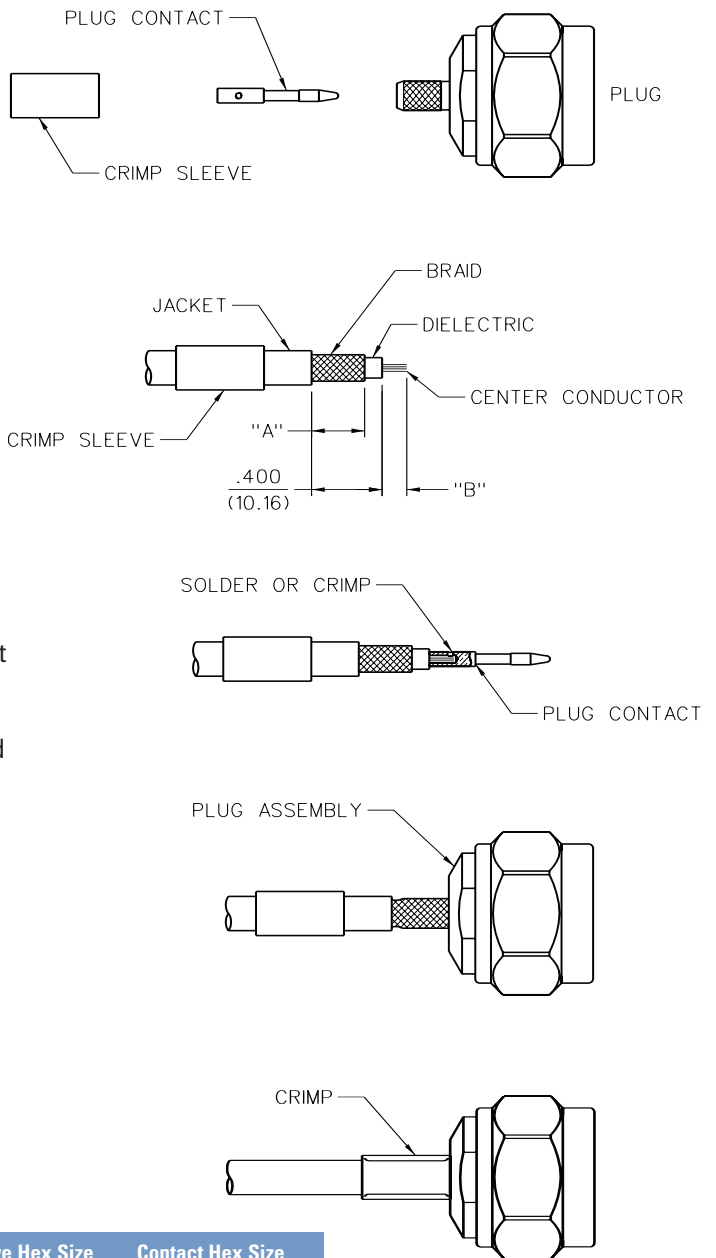

Cable Group	Part No.	"A"	"B"	Crimp Sleeve Hex Size	Contact Hex Size
RG-58/U, 141, 303	138-4407-007	.301 (7.65)	.140 (3.56)	.213 (5.41)	.068 (1.73)
RG-55/U, 142, 223, 400	138-4408-007	.301 (7.65)	.140 (3.56)	.213 (5.41)	.068 (1.73)
RG-8, 213	138-4416-007	.385 (9.78)	.170 (4.32)	.429 (10.90)	.111 (2.82)
RG-9, 214	138-4418-007	.385 (9.78)	.170 (4.32)	.429 (10.90)	.111 (2.82)
LMR-400, BELDEN 9913	138-4449-007	.385 (9.78)	.170 (4.32)	.429 (10.90)	.116 (2.95)

Tool	Assembly	
	138-4407/4408-007	138-4416/4418/4449-007
Crimp Frame	140-0000-967	140-0000-967
Die Set	140-0000-990	140-0000-991

## Type N Right Angle Plug Crimp Style for RG-316, 316DS, 58, and 142 Flexible Cable

1. Identify connector parts (3 piece parts).
2. Strip cable to dimensions shown. Do not nick center conductor. A wire stripper of correct size is recommended for this step. Twist stranded center conductor into tight bundle and tin (optional). Slide crimp sleeve onto jacket of cable.
3. Flare braid and slide plug connector assembly over cable dielectric and under braid. Make sure cable dielectric bottoms against plug contact as shown. Solder center conductor to contact through rear access port. Use a minimum amount of solder for a full fillet joint.
4. Arrange braid uniformly around crimp stem. Slide crimp sleeve forward and crimp using Johnson ergonomic hand crimp frame 140-0000-967 with recommended hex size die set. Screw end cap into access port.



Cable Group	Part No.	"A"	Crimp Sleeve Hex Size
RG-316/U, 161, 174, 188	138-4403-107	.755 (19.18)	.128 (3.25)
RG-316 DS, 188 DS	138-4404-107	.755 (19.18)	.151 (3.84)
RG-58/U, 141, 303	138-4407-107	.788 (20.02)	.213 (5.41)
RG-55/U, 142, 223, 400	138-4408-107	.788 (20.02)	.213 (5.41)

Assembly	
<b>Tool</b>	<b>138-4403/4404/4407/4408-107</b>
Crimp Frame	140-0000-967
Die Set	140-0000-990

## Type N Right Angle Plug Crimp Style for RG-213 and 214 Flexible Cable

1. Identify connector parts (3 piece parts).
2. Strip cable to dimensions shown. Do not nick center conductor. A wire stripper of correct size is recommended for this step. Slide crimp sleeve onto jacket of cable.
3. Flare braid and slide plug connector assembly over cable dielectric and under braid. Make sure center conductor is contained within plug contact as shown. Center conductor should not protrude above slots in plug contact and cable dielectric should not touch plug contact. Solder center conductor to plug contact through rear access port. Use a minimum amount of solder for a full fillet joint.
4. Arrange braid uniformly around crimp stem. Slide crimp sleeve forward and crimp using Johnson ergonomic hand crimp frame 140-0000-967 with recommended hex size die set. Screw end cap into access port.

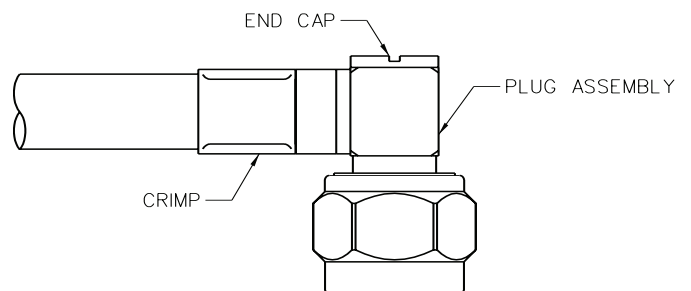
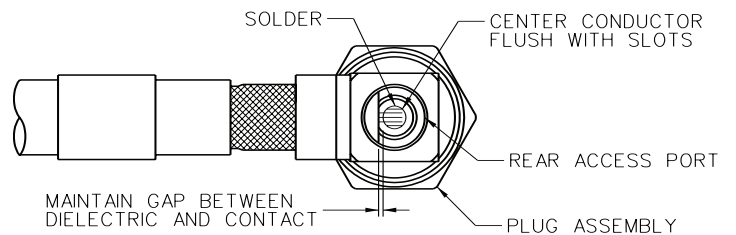
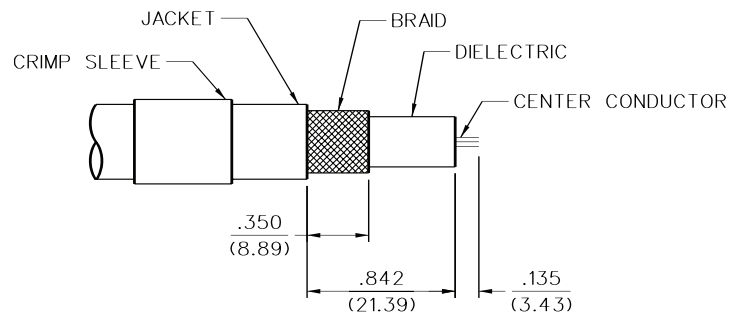
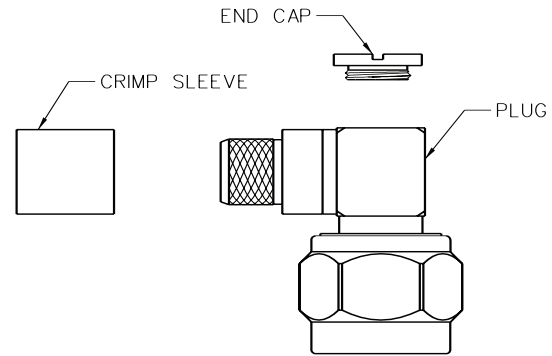

Cable Group	Part No.	Crimp Sleeve Hex Size
RG-8, 213	138-4416-107	.429 (10.90)
RG-9, 214	138-4418-107	.429 (10.90)

Tool	Assembly
Crimp Frame	140-0000-967
Die Set	140-0000-991



## Type N Straight Plug Solder Style for Semi-Rigid Cable

1. Identify connector parts (2 piece parts) and tools (5 piece parts).
2. Strip cable jacket and dielectric to dimension shown. Do not nick center conductor. Clean all debris from cable.
3. Place plug contact onto center conductor, insert appropriate sized solder shim between cable jacket and contact.
4. Insert contact into location fixture and clamp cable in vise. Tighten stop screw until light pressure is applied between contact, solder shim and cable jacket.
5. Solder contact to center conductor through solder hole using .020 (.051) diameter flux core solder wire. Use a minimum amount of solder for a good joint.
6. After solder joint has cooled, loosen stop screw and remove solder shim. Remove cable from vise and remove any excess solder from contact with a sharp blade and clean all debris from contact and cable.
7. Insert contact and cable into plug connector assembly, making sure cable jacket bottoms out against internal shoulder of connector assembly. Insert location fixture into connector assembly and clamp cable in vise. Tighten stop screw until light pressure is applied between connector assembly and cable jacket.
8. Solder connector body to cable jacket, using a minimum amount of solder for a full fillet joint. Allow assembly to cool before removing connector from vise.

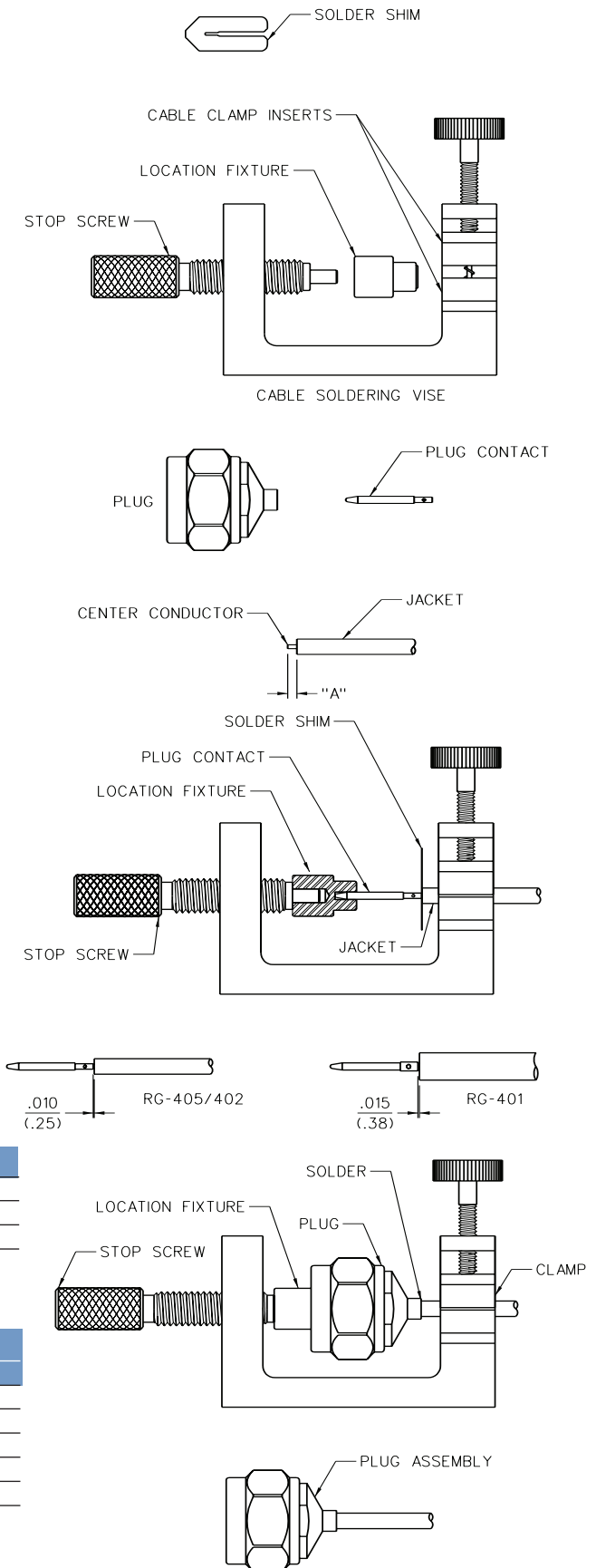

Cable Group	Part No.	"A"
RG-405, .086 Semi-Rigid	138-4693-001	.085 (2.16)
RG-402, .141 Semi-Rigid	138-4694-001	.085 (2.16)
RG-401, .250 Semi-Rigid	138-4696-001	.100 (2.54)

Tool	Assembly		
	138-4693-001	138-4694-001	138-4696-001
Solder Shim	140-0000-984	140-0000-984	140-0000-985
Location Fixture	140-0000-983	140-0000-983	140-0000-983
Cable Vise	140-0000-962	140-0000-962	140-0000-962
Clamp Inserts	140-0000-964	140-0000-965	140-0000-986
Stop Screw	140-0000-981	140-0000-981	140-0000-981

## Type N Straight Plug One Piece Style for Semi-Rigid Cable

1. Identify connector and tools (4 piece parts).
2. Strip cable jacket and dielectric to dimension shown. Do not nick center conductor.
3. Bevel end of cable center conductor per appropriate dimensional profile.
4. Clean all debris from prepared cable and insert cable into connector assembly, making sure cable jacket bottoms out against internal shoulder of connector assembly and center conductor engages with internal captivated plug contact.
5. Insert location fixture into connector assembly and clamp cable in vise. Tighten stop screw until light pressure is applied between connector assembly and cable jacket.
6. Solder connector body to cable jacket, using a minimum amount of solder for a full fillet joint. Allow assembly to cool before removing connector from vise.

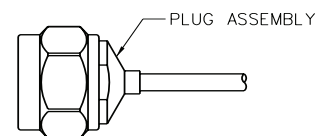
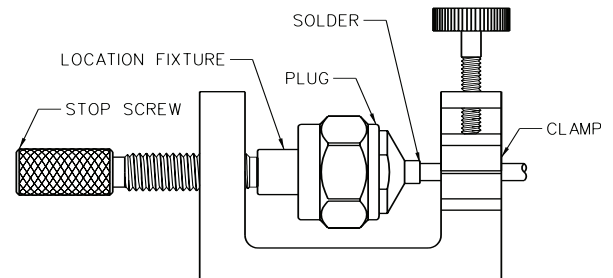
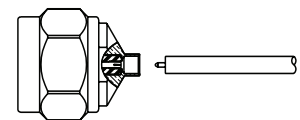

Cable Group	Part No.	"A"	"B"
RG-405, .086 Semi-Rigid	138-4693-011	.085 (2.16)	.014 (0.36)
RG-402, .141 Semi-Rigid	138-4694-011	.085 (2.16)	.022 (0.56)
RG-401, .250 Semi-Rigid	138-4696-011	.150 (3.81)	.045 (1.14)

Tool	Assembly		
	138-4693-011	138-4694-011	138-4696-011
Location Fixture	140-0000-983	140-0000-983	140-0000-983
Cable Vise	140-0000-962	140-0000-962	140-0000-962
Clamp Inserts	140-0000-964	140-0000-965	140-0000-986
Stop Screw	140-0000-981	140-0000-981	140-0000-981

## Type N Bulkhead Jack Crimp Style for RG-316 and 316DS Flexible Cable

1. Identify connector parts (6 piece parts).
2. Strip cable to dimensions shown. Do not nick center conductor. A wire stripper of correct size is recommended for this step. Tin center conductor if contact will be solder attached. Do not tin center conductor if contact will be crimp attached. Slide crimp sleeve onto jacket of cable.
3. Assemble rear contact onto cable as shown. Rear contact should butt against cable dielectric during attachment.
 

**Solder Attachment:** Solder rear contact to center conductor through solder hole using .020 (.051) diameter flux core solder wire. Use a minimum amount of solder for a good joint.

**Crimp Attachment:** Crimp rear contact to center conductor using Johnson indent hand tool 140-0000-970. Crimp location should be centered between end of rear contact and solder hole using positioning tool 140-0000-971. Crimp attachment to solid center conductor cables is not recommended.
4. Flare braid and slide bulkhead jack connector assembly over rear contact and under braid. Rear contact must engage fully with internal captivated jack contact. Cable jacket should be located near end of crimp stem when contacts are fully engaged.
5. Arrange braid uniformly around crimp stem. Slide crimp sleeve forward and crimp using Johnson ergonomic hand crimp frame 140-0000-967 with recommended hex size die set. Maintain forward pressure on cable while crimping.
6. Add gasket, lock washer and mounting nut when installing connector to panel.



Cable Group	Part No.	Crimp Sleeve Hex Size	Contact Crimp
RG-316/U, 161, 174, 188	138-4303-407	.128 (3.25)	8 INDENT
RG-316 DS, 188 DS	138-4304-407	.151 (3.84)	8 INDENT

Assembly	
Tool	138-4303/4304-407
Crimp Frame	140-0000-967
Die Set	140-0000-990
Contact Tool	140-0000-970
Positioner	140-0000-971

## Type N Bulkhead Jack Crimp Style for RG-58, 142, 213, 214 and LMR-400 Flexible Cable

1. Identify connector parts (6 piece parts).
2. Strip cable to dimensions shown. Do not nick center conductor. A wire stripper of correct size is recommended for this step. Tin center conductor if contact will be solder attached. Do not tin center conductor if contact will be crimp attached. Slide crimp sleeve onto jacket of cable.
3. Assemble jack contact onto cable as shown. Jack contact should butt against cable dielectric during attachment.
 

**Solder Attachment:** Solder jack contact to center conductor through solder hole using .020 (.051) diameter flux core solder wire. Use a minimum amount of solder for a good joint.

**Crimp Attachment:** Crimp jack contact to center conductor using Johnson ergonomic hand crimp frame 140-0000-967 with recommended hex size die set. Crimp location should be on end of jack contact next to cable dielectric. Crimp attachment to solid center conductor cables is not recommended.
4. Flare braid and slide bulkhead jack connector assembly over jack contact and under braid. Seat bulkhead jack connector assembly firmly onto contact. Arrange braid uniformly around crimp stem. Slide crimp sleeve forward and crimp using Johnson ergonomic hand crimp frame 140-0000-967 with recommended hex size die set. Maintain forward pressure on cable while crimping.
5. Add gasket, lock washer and mounting nut when installing connector to panel.

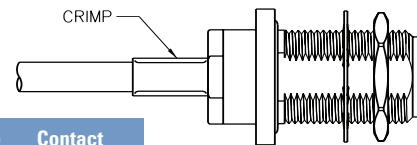
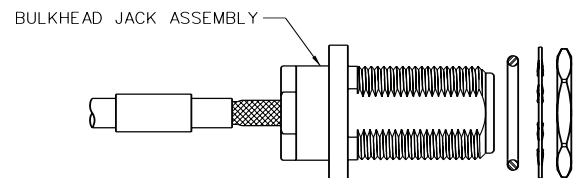
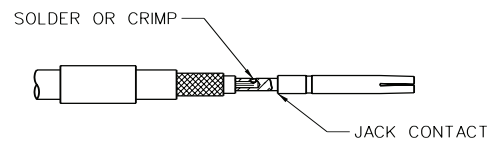
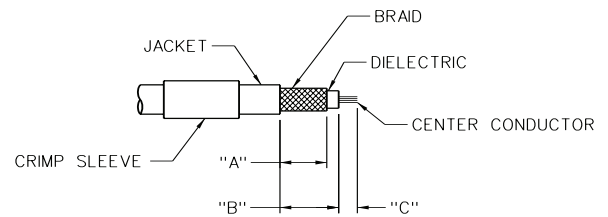
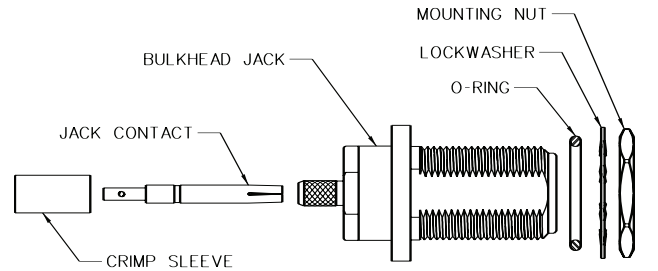

Cable Group	Part No.	"A"	"B"	"C"	Crimp Sleeve Hex Size	Contact Hex Size
RG-58/U, 141, 303	138-4307-407	.310 (7.87)	.389 (9.88)	.135 (3.43)	.213 (5.41)	.068 (1.73)
RG-55/U, 142, 223, 400	138-4308-407	.310 (7.87)	.389 (9.88)	.135 (3.43)	.213 (5.41)	.068 (1.73)
RG-8, 213	138-4316-407	.385 (9.78)	.400 (10.16)	.165 (4.19)	.429 (10.90)	.111 (2.82)
RG-9, 214	138-4318-407	.385 (9.78)	.400 (10.16)	.165 (4.19)	.429 (10.90)	.111 (2.82)
LMR-400, BELDEN 9913	138-4349-407	.385 (9.78)	.400 (10.16)	.165 (4.19)	.429 (10.90)	.116 (2.95)

Tool	Assembly	
	138-4307/4308-407	138-4316/4318/4349-407
Crimp Frame	140-0000-967	140-0000-967
Die Set	140-0000-990	140-0000-991

## Type N Bulkhead Jack Solder Style for Semi-Rigid Cable

1. Identify connector parts (8 piece parts) and tools (4 piece parts).
2. Strip cable jacket and dielectric to dimension shown. Do not nick center conductor. Clean all debris from cable.
3. Slide stem over cable jacket, keeping stem correctly oriented to end of cable.
4. Insert jack contact into rear insulator. Make sure insulator is correctly oriented to contact. Place jack contact and rear insulator onto center conductor, keeping insulator correctly oriented between cable jacket and contact.
5. Slide stem away from jack contact. Insert contact into stop screw and clamp cable in vise. Tighten stop screw until light pressure is applied between jack contact, rear insulator and cable jacket.
6. Solder jack contact to center conductor through solder hole using .020 (.051) diameter flux core solder wire. Use a minimum amount of solder for a good joint.
7. After solder joint has cooled, remove cable from vise and remove any excess solder from jack contact with a sharp blade and clean all debris from contact and rear insulator.
8. Slide stem over rear insulator and tighten stem into location fixture until stem bottoms out.
9. Insert cable into vise, but do not clamp. Insert jack contact into stop screw and tighten location fixture until stop screw bottoms out. Clamp cable in vise.
10. Solder stem to cable jacket, using a minimum amount of solder for a full fillet joint. Allow assembly to cool before removing from vise.
11. After solder joint has cooled, un-clamp cable and remove location fixture from stop screw and cable assembly. Insert front insulator into bulkhead jack body. Insert cable assembly into body and tighten to 25-30 in-lbs.
12. Add gasket, lock washer and mounting nut when installing connector to panel.

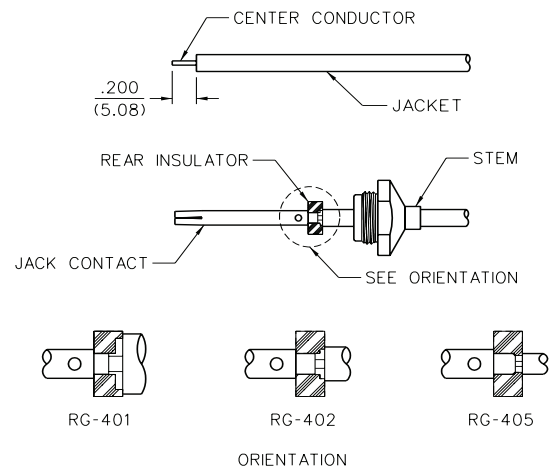
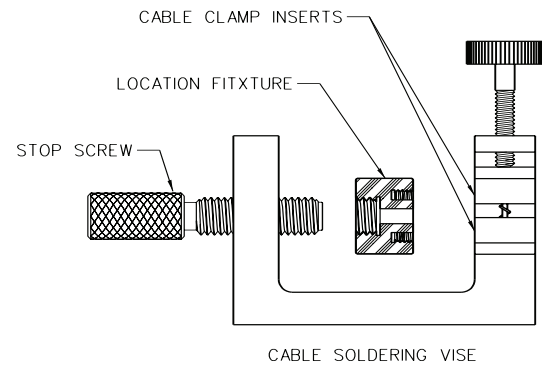
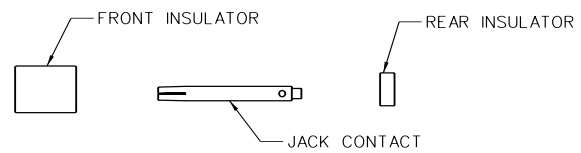
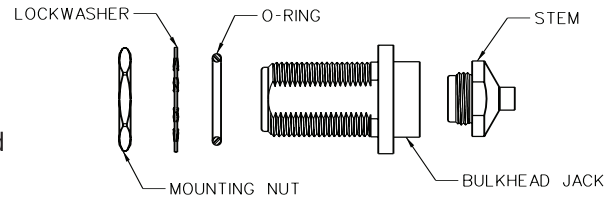

## Type N Bulkhead Jack Solder Style for Semi-Rigid Cable (cont'd)

Cable Group	Part No.
RG-405, .086 Semi-Rigid	138-4593-401
RG-402, .141 Semi-Rigid	138-4594-401
RG-401, .250 Semi-Rigid	138-4596-401

Tool	Assembly		
	138-4593-401	138-4594-401	138-4596-401
Stop Screw	140-0000-972	140-0000-972	140-0000-972
Cable Vise	140-0000-962	140-0000-962	140-0000-962
Clamp Inserts	140-0000-964	140-0000-965	140-0000-986
Location Fixture	140-0000-987	140-0000-988	140-0000-989

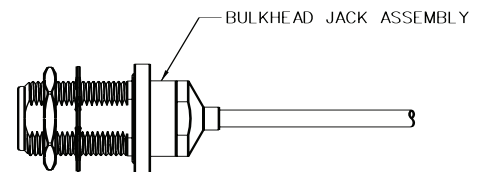
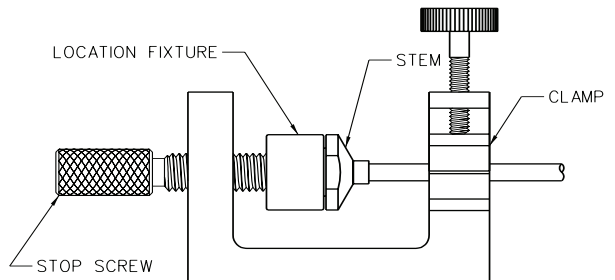
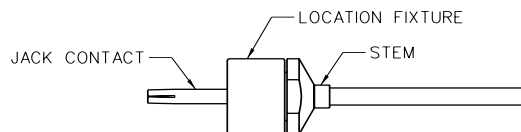
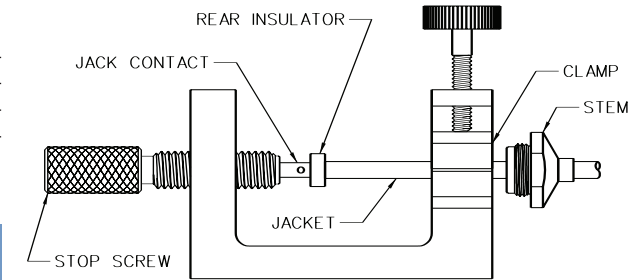

## COMPETITOR CROSS REFERENCE

Johnson	Radiall	M/A-Com	Amphenol	Tyco/Amp	Telegartner	Rosenberger	Huber-Suhner
138-4303-407	R161311300	3004-7388-10	82-6156			53K507-802N3	
138-4304-407	R161311300					53K507-803N3	
138-4307-407	R161329000	3004-7341-10	82-5378	1-225667-2	J01021A0147	53K507-106N3	24N-50-3-11C
138-4308-407	R161329200	3004-7341-10	82-5373	225363-2	J01021A0148	53K507-108N3	24N-50-3-12C
138-4316-407	R161331000	N15H61H001X99	82-346-RFX	225094-2	J01021A0060	53K501-115N3	24N-50-7-14C
138-4318-407	R161331200	N15H61H004X99		225667-1	J01021A0092	53K501-117N3	24N-50-7-15C
138-4349-407	R161331060		82-6143-1000				
138-4403-007	R161072000	3031-7338-10			J01020A0103	53S107-802N3	
138-4403-107	R161181000		82-6048-1000		J01020A0040		
138-4404-007	R161072000				J01020A0104	53S107-803N3	
138-4404-107	R161181300				J01020A0039		
138-4407-007	R161082000	3031-7358-10	82-5375	1-225661-2	J01010A0108	53S107-106N3	11N-50-3-28C
138-4407-107	R161182000			1-225669-2	J01020A0035	53S205-315N3	16N-50-3-26C
138-4408-007	R161083000	3031-7341-10	82-5370	225699-1	J01020A0113	53S107-108N3	11N-50-3-29C
138-4408-107	R161183000		82-4442	225365-2	J01020A0036	53S205-317N3	16N-50-3-27C
138-4416-007	R161075000	N15A61H001X99	82-340	225661-2	J01020A0107	53S101-115N3	11N-50-7-43C
138-4416-107	R161184000	N15B61H001X99	82-336	225669-2	J01020A0046		16N-50-7-30C
138-4418-007	R161088000	N15A61H004X99	82-332	225661-1	J01020A0110	53S101-115N3	11N-50-7-44C
138-4418-107	R161186000	N15B61H004X99	82-4440-1001	225669-1	J01020A0045		16N-50-7-31C
138-4449-007	R161075060		82-340-1052		J01020A0127	53S101-1N9N3	
138-4593-401	R161335200	3004-7985-00	82-6093-RFX	228658-2	J01021H0087	52K504-271N3	24N-50-2-14
138-4594-401	R161336000	3004-7941-00	82-6097-RFX	228658-1	J01021A0151	53K504-272N3	24N-50-3-14
138-4596-401	R161337200		82-6162		J01021A0109	53K504-273N3	24N-50-5-39C
138-4693-001	R161050300	3001-7985-00		1057094-1			11N-50-2-14
138-4693-011	R161050300	3001-7985-00					11N-50-2-14
138-4694-001	R161051000	3001-7941-00	82-5955-RFX	1057088-1	J01020A0109	53S101-272B1	11N-50-3-13
138-4694-011	R161051000	3001-7941-00	82-5955-RFX		J01020A0109	53S101-272B1	11N-50-3-13
138-4696-001	R161054000		82-6124		J01020A0112	53S101-273B1	11N-50-5-39C
138-4696-011	R161054000		82-6124		J01020A0112	53S101-273B1	11N-50-5-39C
138-4701-407	R161586137	N15M35999X99			J01021A1084	53K505-200N3	
138-4701-607	R161404000	3052-0000-10	82-97	1-1337418-0	J01021A1082	53K401-200N3	23N-50-0-23
138-4901-407	R161730000	N15R07999X99	82-66		J01024A1088	53K501-K00N3	34N-50-0-51
138-4901-807	R161705000	3680-0000-02	82-101	227945-2	J01024A1092	53K101-K00N3	31N-50-0-51
138-4901-817	R161703000	3681-0000-02	82-100	1058661-1	J01024A1094	53K101-S00N3	32N-50-0-51

## Emerson Network Power Connectivity Solutions

**Johnson**  
299 Johnson Avenue  
Waseca, MN 56093  
USA

**Tel: 800.247.8256**  
**Fax: 507.833.6287**

**[www.EmersonNetworkPower.com/Connectivity](http://www.EmersonNetworkPower.com/Connectivity)**

## About Emerson Network Power Connectivity Solutions

Emerson Network Power Connectivity Solutions, an Emerson business, serves the needs of wireless communications, telephony and data networks, CATV, security systems, health care and industrial facilities with a full spectrum of broadband copper and fiber optic connectivity products. For more information, visit [www.EmersonNetworkPower.com/Connectivity](http://www.EmersonNetworkPower.com/Connectivity).

## About Emerson

Emerson (NYSE: EMR), based in St. Louis, is a global leader in bringing technology and engineering together to provide innovative solutions to customers through its network power, process management, industrial automation, climate technologies, and appliance and tools businesses. Sales in fiscal 2005 were \$17.3 billion. For more information, visit [www.gotoemerson.com](http://www.gotoemerson.com).

## Emerson Network Power.

The global leader in enabling business-critical continuity.

- AC Power Systems
- Embedded Power
- Outside Plant
- Connectivity
- Inbound Power
- Precision Cooling
- DC Power Systems
- Integrated Cabinet Solutions
- Site Monitoring and Services

**[EmersonNetworkPower.com](http://www.EmersonNetworkPower.com)**





Компания «ЭлектроПласт» предлагает заключение долгосрочных отношений при поставках импортных электронных компонентов на взаимовыгодных условиях!

Наши преимущества:

- Оперативные поставки широкого спектра электронных компонентов отечественного и импортного производства напрямую от производителей и с крупнейших мировых складов;
- Поставка более 17-ти миллионов наименований электронных компонентов;
- Поставка сложных, дефицитных, либо снятых с производства позиций;
- Оперативные сроки поставки под заказ (от 5 рабочих дней);
- Экспресс доставка в любую точку России;
- Техническая поддержка проекта, помощь в подборе аналогов, поставка прототипов;
- Система менеджмента качества сертифицирована по Международному стандарту ISO 9001;
- Лицензия ФСБ на осуществление работ с использованием сведений, составляющих государственную тайну;
- Поставка специализированных компонентов (Xilinx, Altera, Analog Devices, Intersil, Interpoint, Microsemi, Aeroflex, Peregrine, Syfer, Eurofarad, Texas Instrument, Miteq, Cobham, E2V, MA-COM, Hittite, Mini-Circuits, General Dynamics и др.);

Помимо этого, одним из направлений компании «ЭлектроПласт» является направление «Источники питания». Мы предлагаем Вам помощь Конструкторского отдела:

- Подбор оптимального решения, техническое обоснование при выборе компонента;
- Подбор аналогов;
- Консультации по применению компонента;
- Поставка образцов и прототипов;
- Техническая поддержка проекта;
- Защита от снятия компонента с производства.



#### Как с нами связаться

**Телефон:** 8 (812) 309 58 32 (многоканальный)

**Факс:** 8 (812) 320-02-42

**Электронная почта:** [org@eplast1.ru](mailto:org@eplast1.ru)

**Адрес:** 198099, г. Санкт-Петербург, ул. Калинина, дом 2, корпус 4, литера А.