

Universal motor control evaluation board based on the STM8S103F2 MCU and T1235T Triac

Data brief

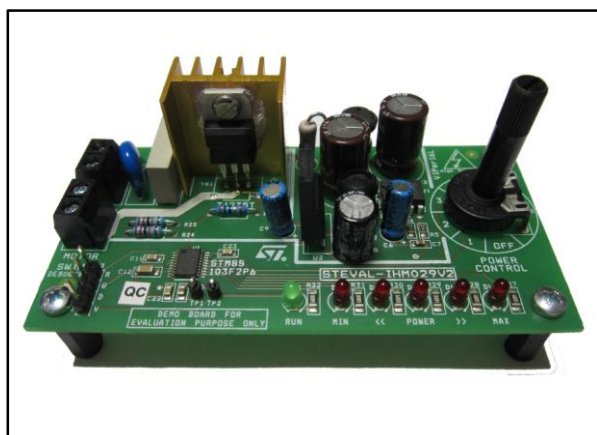

- IEC 61000-4-5 pre-compliance test passed (surge up to 2 kV)
- RoHS compliant

Description

The STEVAL-IHM029V2 is a low-cost universal motor control evaluation board designed for the home appliance market, with particular focus on vacuum cleaners, food processors and power tools. This system features the 20-pin, 8-bit STM8S103F2 microcontroller running at 16 MHz (user-trimmable internal RC clock), featuring 4 KB of Flash memory, a 10-bit A/D converter, 8/16 bit timers, communication interfaces and 640 bytes of E2PROM. The power supply circuitry features the VIPer16L, an off-line converter with an 800 V avalanche-rugged power section, operating at 60 kHz.

The STEVAL-IHM029V2 especially targets vacuum cleaner applications with power up to 900 W and fulfills the requirements of the 2009/125/EC EU directive, applicable starting in September 2017, thanks to the T1235T, a 12 A 800 V high performance Triac. The motor control is based on phase-angle.

In order to limit in-rush current and possible current peaks, the evaluation board features a soft-start routine and a smooth power change function. The board passed the pre-compliance tests for EMC directives IEC 61000-4-4 (burst up to 8 kV) and IEC 61000-4-5 (surge up to 2 kV). In standby mode, the STEVAL-IHM029V2 has an overall power consumption below 300 mW.

Features

- Input voltage range: 90-265 VAC, 50/60 Hz
- 12 VDC / 5 VDC auxiliary power supply based on the VIPer16L in buck converter topology
- Total power consumption below 300 mW in standby mode
- Maximum output power: 1500 W
- 20-pin, 8-bit STM8S103F2 MCU as main controller
- Employs zero-voltage switching (ZVS) to synchronize MCU events with the voltage mains
- Motor driven by T1235T Triac in phase-angle control
- 5 power levels and standby mode selectable by potentiometer
- 5 LEDs to display the power level of the board
- "RUN" LED to indicate the board is functioning
- Standard in-circuit programming connector
- IEC 61000-4-4 pre-compliance test passed (burst up to 8 kV)

1 Schematic diagram

Figure 1: STEVAL-IHM029V2 circuit schematic

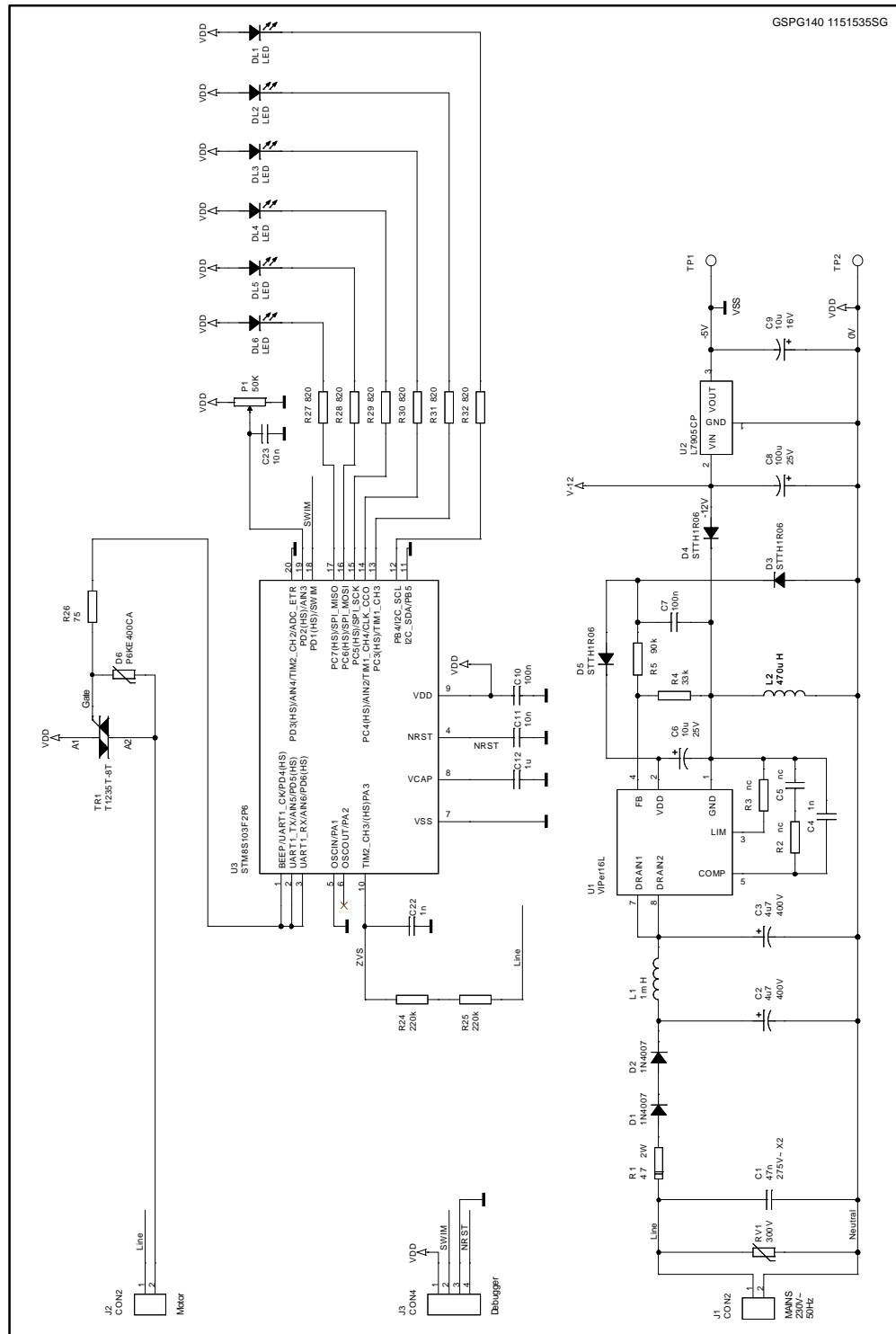

2 Revision history

Table 1: Document revision history

Date	Rev	Changes
02-Feb-2015	1	First release.

IMPORTANT NOTICE – PLEASE READ CAREFULLY

STMicroelectronics NV and its subsidiaries ("ST") reserve the right to make changes, corrections, enhancements, modifications, and improvements to ST products and/or to this document at any time without notice. Purchasers should obtain the latest relevant information on ST products before placing orders. ST products are sold pursuant to ST's terms and conditions of sale in place at the time of order acknowledgement.

Purchasers are solely responsible for the choice, selection, and use of ST products and ST assumes no liability for application assistance or the design of Purchasers' products.

No license, express or implied, to any intellectual property right is granted by ST herein.

Resale of ST products with provisions different from the information set forth herein shall void any warranty granted by ST for such product.

ST and the ST logo are trademarks of ST. All other product or service names are the property of their respective owners.

Information in this document supersedes and replaces information previously supplied in any prior versions of this document.

© 2015 STMicroelectronics – All rights reserved



Компания «ЭлектроПласт» предлагает заключение долгосрочных отношений при поставках импортных электронных компонентов на взаимовыгодных условиях!

Наши преимущества:

- Оперативные поставки широкого спектра электронных компонентов отечественного и импортного производства напрямую от производителей и с крупнейших мировых складов;
- Поставка более 17-ти миллионов наименований электронных компонентов;
- Поставка сложных, дефицитных, либо снятых с производства позиций;
- Оперативные сроки поставки под заказ (от 5 рабочих дней);
- Экспресс доставка в любую точку России;
- Техническая поддержка проекта, помощь в подборе аналогов, поставка прототипов;
- Система менеджмента качества сертифицирована по Международному стандарту ISO 9001;
- Лицензия ФСБ на осуществление работ с использованием сведений, составляющих государственную тайну;
- Поставка специализированных компонентов (Xilinx, Altera, Analog Devices, Intersil, Interpoint, Microsemi, Aeroflex, Peregrine, Syfer, Eurofarad, Texas Instrument, Miteq, Cobham, E2V, MA-COM, Hittite, Mini-Circuits, General Dynamics и др.);

Помимо этого, одним из направлений компании «ЭлектроПласт» является направление «Источники питания». Мы предлагаем Вам помощь Конструкторского отдела:

- Подбор оптимального решения, техническое обоснование при выборе компонента;
- Подбор аналогов;
- Консультации по применению компонента;
- Поставка образцов и прототипов;
- Техническая поддержка проекта;
- Защита от снятия компонента с производства.



Как с нами связаться

Телефон: 8 (812) 309 58 32 (многоканальный)

Факс: 8 (812) 320-02-42

Электронная почта: org@eplast1.ru

Адрес: 198099, г. Санкт-Петербург, ул. Калинина, дом 2, корпус 4, литера А.