



Platform Manager Development Kit

User's Guide

Introduction

Thank you for choosing the Platform Manager™ Development Kit. This user's guide describes how to start using the Platform Manager Development Kit, an easy-to-use system for evaluating and designing with the Platform Manager mixed-signal device. The kit serves as a development test environment to build designs for power supply management functions such as sequencing, power supply fault logging, trimming, reset generation, high-side MOSFET drive and user logic I/O expansion in an FPGA.

Note: Static electricity can severely shorten the life span of electronic components. Use static-safe handling practices when using this development kit. Store the board in the supplied ESD safe bag. Handle all cables and interconnects in a static-safe environment.

Features

The Platform Manager Development Kit includes:

- Platform Manager Evaluation Board containing the Platform Manager LPTM10-12107 device in a 208-ball ftBGA package
- USB programming support on-board
- 4Mbit SPI Flash memory for logging data and faults
- SPI and I²C interfaces
- 2x16 expansion header for I²C, SPI and general purpose data bus, I/O
- Two 4-bit DIP switches
- Three push-buttons for input control, reset, etc.
- DAC and A/D converters for trimming power supplies
- LED displays
- LCD display
- Adjustable potentiometers for user faults or demos
- Thermistor circuit for temperature sensing
- LDO to demo sequencing and trim functions
- DC-DC convertor to demo sequencing and trim functions
- Two LDOs for main chip power and VCCIO supplies.
- VMON, voltage monitors for on-board and off-board power supply monitoring
- Off-board screw connectors for user loads and testing
- Prototyping/interface connections
- Pre-loaded Demo – The Platform Manager Development Kit contains a pre-loaded demo design that illustrates many of the key features of the Platform Manager device.
- USB Connector Cable – The Platform Manager Evaluation Board is programmed via the USB cable driven from the user's computer. This USB cable is included in the Platform Manager Development Kit.
- Power Supply – The Platform Manager Evaluation board is powered by an AC adapter (included).
- [Platform Manager Development Kit QuickSTART Guide](#) – Provides information on connecting the Platform Manager Evaluation Board, getting started with the pre-programmed demo, and starting your own design.
- [Platform Manager Development Kit Web Page](#) – The Platform Manager Development Kit Web Page provides access to the latest documentation, demo designs and additional resources.

The contents of this user's guide includes demo operation descriptions, top-level functionality descriptions of various portions of the evaluation board, descriptions of the on-board connectors, switches and a complete set of schematics of the Platform Manager Evaluation Board.

Figure 1. Platform Manager Evaluation Board, Top Side

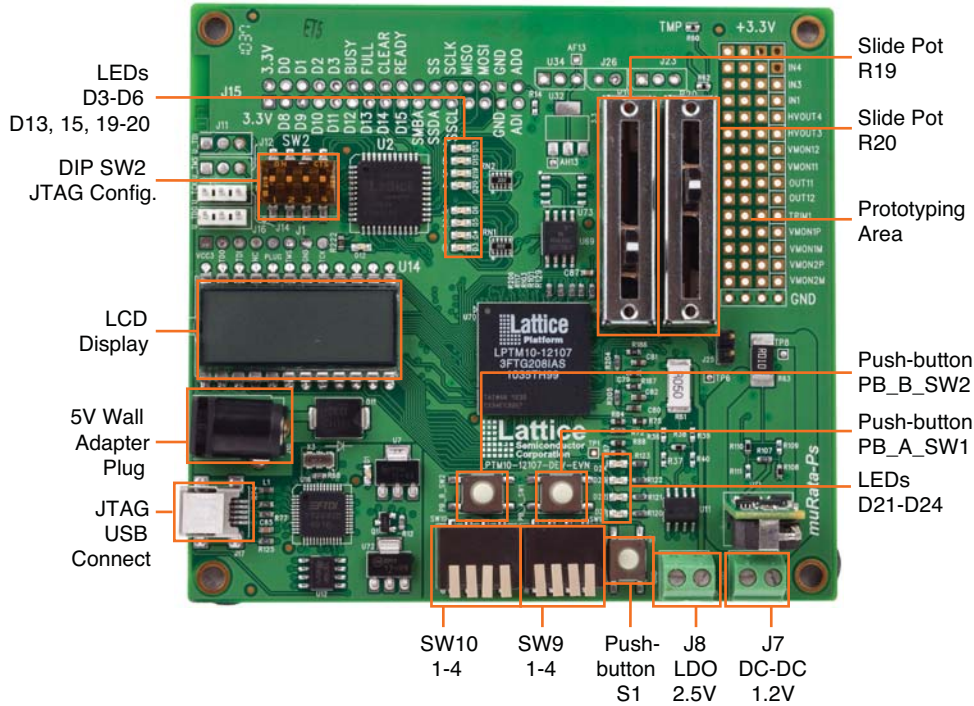

Use the QuickSTART Guide First

Please use the [Platform Manager Development Kit QuickSTART Guide](#) that comes with the Platform Manager Development Kit to get started. The QuickSTART Guide provides a “fast path” for working with the Platform Manager Evaluation Board and the pre-programmed Platform Manager demo. This user's guide augments the QuickSTART guide by providing detailed descriptions of the board demos and schematic descriptions of the Platform Manager Evaluation Board.

Platform Manager Device

The Platform Manager (LPTM10-12107) device is at the heart of the Platform Management Development Kit. This device comes in a 208-ball ftBGA package and integrates both analog functions and digital functions, necessary for advanced board and system level power control. It is a feature-rich device that allows for full power control and reset generation or Platform Management.

Platform Manager is divided into a CPLD section and an FPGA section. The CPLD portion of the Platform Manager is user-configurable logic that is tightly coupled to the power management analog signaling of the Platform Manager. The FPGA section allows for more expansive and sophisticated, LUT-based control of the Platform Manager analog signaling as well as user-defined glue logic. See the [Platform Manager Data Sheet](#) for detailed information.

Analog features consist of 12 VMON analog voltage monitors with differential inputs for remote sense. Four high-voltage FET drivers are programmable for both slew rate and voltages up to 12V for driving high-side MOSFETs. For trimming and margin control, the device uses A/D converters and D/A converters for closed loop trim, whereby up to eight power supplies can be trimmed.

On the digital side, there are multiple internal clocks generated from an 8MHz internal oscillator and 16 open-drain outputs. These are controlled by the CPLD section. The FPGA section contains 640 LUTs of FPGA logic and sup-

ports flexible multiple voltage and I/O standard logic pins. The device is programmed with a JTAG interface and runs off a 3.3V rail.

The FPGA section of the Platform Manager is optimized to meet the requirements of board management functions including reset distribution, boundary scan management, fault logging, FPGA load control, and system bus interface. The FPGA section uses look-up tables (LUTs) and distributed memories for flexible and efficient logic implementation. This instant-on capability enables the Platform Manager devices to integrate control functions that are required as soon as power is applied to the board.

Power management functions can be integrated into the CPLD and digital board management functions can be integrated into the FPGA using the LogiBuilder tool provided by PAC-Designer® software. In addition, the FPGA designs can also be implemented in VHDL or Verilog HDL through the ispLEVER® design tool.

The Platform Manager device supports a hardware I²C/SMBus slave interface that can be used to measure voltages through the Analog-to-Digital Converter or is used for trimming and margining using a microcontroller.

There are two JTAG ports integrated into the Platform Manager device: Power JTAG and FPGA JTAG. The Power JTAG interface is used to program the power section of the Platform Manager and the FPGA JTAG is used to configure the FPGA portion of the device. The FPGA configuration memory can be changed in-system without interrupting the operation of the board management section. However, the Power Management section of the platform Manager cannot be changed without interrupting the power management operation.

Figure 2. Device Block Diagram

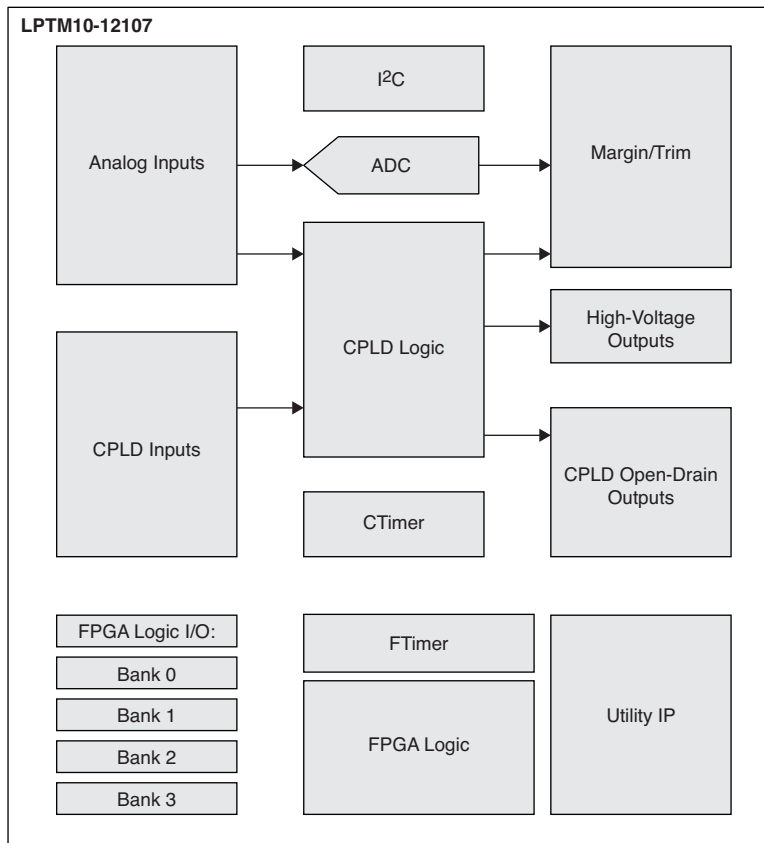

Demonstration Design

The Platform Manager Evaluation Board comes pre-programmed with the Platform Manager Demo to highlight the power control and management abilities of the Platform Manager device. This demo performs the following functions:

- Drives LEDs to represent enable circuits for power supplies
- Reads various VMONs for board power
- Provides two slider pots to fire VMON trip points
- Sequences the LDO and Murata DC-DC power supply
- Receives inputs for switches and push-buttons
- Drives the LCD display panel

Components of this demo include:

- **CPLD LEDs** – There are four LEDs connected to CPLD outputs. LEDs light when open-drain outputs of the CPLD are driven low. These are displayed to represent the board-level power supplies in the example or can be used to show sequencing.
- **FPGA LEDs** – There are eight LEDs connected to FPGA output pins. LEDs light when the FPGA pins are driven low. These are also sequenced to represent power supply enables and display different timing functions.
- **Power Supplies** – The board has two user-programmable power supplies that can be sequenced and trimmed using the Platform Manager and PAC-Designer software. After the LEDs sequence for the three board power supplies, the LDO and DC-DC converter are enabled.
- **Slide Potentiometers** – There are two slide potentiometers available to adjust VMON inputs for monitoring; these are tied to VMON8 and VMON9. The slider pot input to VMON8 and VMON9 has a range of 0V to 3.3V. The inputs can be set to trip on a window comparator within the Platform Manager. The two sliders are used in the demo to start the sequence as well as to cause a fault to occur.
- **LCD Display** – The display is a 3-digit, standard 7-segment display and is driven from 24 FPGA output pins. Segments are ON when each segment decode is driven in opposite polarity to the COM pin. The LCD is toggled at approximately 60Hz using logic in the FPGA. The demo displays a hexadecimal value on the LCD, to change the display, set the DIP switches.
- **Hardware Power Supply Margin Function** – The margining of the LDO and Murata DC-DC converter is done with a signal from the push-buttons. There are two push-buttons adjacent to the DIP switches. Pressing PBA_SW1 and PBB_SW2 drives the margin control to select between closed loop trim and margin settings. Push-buttons are tied high with a pull-up to Bank2. Pressing PBB_SW2/PBA_SW1 drives a low on FPGA inputs. The margining options shown in Table 1 are exercised in Step 5 of the demo.

Table 1. Margining Options

PBAB_SW2, PBA_SW1	Decoded in FPGA	LDO U11 2.5V	DC-DC Module 1.2V
[High, High] 1,1 not pressed	Closed Loop Trim	2.5	1.2V
[High, Low] 1,0	Margin setting 1	2.375	1.14V
[Low, High] 0,1	Margin setting 2	2.625	1.26V
[Low, Low] 0,0	Margin setting 3	2.5V	1.2V

Initial Board Setup

- Set all DIP switches in SW9 and SW10 to the up/off position
- Set all DIP switches in SW2 to the on position
- Set slide pots R19 and R20 in the down position, toward the center of the board
- No jumpers should be installed

Step 1. Test Board Power, LED D1, and All Power Supplies

Step 1 shows the ability of the Platform Manager to monitor and sequence input power rails and on-board supplies. There are five supplies connected to five separate VMON inputs on the Platform Manager Evaluation Board. The first three supplies, 5V, 3.3V, and 2.5V, are power rails that the Platform Manager does not enable; it only monitors them. The second 2.5V supply is an LDO that the Platform Manager enables and then monitors, and the 1.2V supply is a DC-DC converter that the Platform Manager enables and then monitors. There is also control from the Margin/Trim outputs on the Platform Manager to each of these supplies. Table 2 shows how the four LEDs in the display follow the progress of the monitoring, enabling, and sequencing.

- Plug the 5V wall plug supply into the board supply plug.
- The blue LED D1 will be on and will remain lit while the board is powered.
- LEDs D21-D23 cycle through Steps 1-6 as shown in Table 2. Failure to cycle through the steps indicates a power supply error.

Table 2. CPLD LED Pattern 1

Step	D24	D23	D22	D21	Function
1	off	off	off	ON	Wait for 5V supply good
2	off	off	ON	off	Wait for 3.3V supply good
3	off	off	ON	ON	Wait for 2.5V supply good
4	off	ON	off	off	Enable 2.5V LDO, wait for 2.5 good
5	off	ON	off	ON	Enable 1.2V LDO, wait for 1.2 good
6	off	ON	ON	off	Waiting for slide pots R19 and R20 to be raised to top of slide

Step 2. Test Slide Pots R19-R20 and LEDs D3-D6, D13-D14, D19-D20 and D21-D24

Step 2 tests the position of the slide pots, and displays patterns and information on the LEDs and LCD display. The slide pots are connected to two VMON inputs of the Platform Manager and are set to be “good” at about 3V. The demo checks for both pots to be at good levels, then continues to the next step, which is to exercise various digital outputs from the Platform Manager. Platform Manager outputs connect to the LEDs, as shown in the tables below, and also to the LCD. The Closed Loop Trimming function for the LDO and DC-DC converter is also enabled at this point.

- Move both slide pots R19 and R20 to the top (board edge) of their travel. LEDs D21-D24 will cycle on and off as shown in Table 3.

Table 3. CPLD LED Pattern 2

State	D24	D23	D22	D21
1	off	ON	off	ON
2	ON	off	ON	Off
Back to State 1				

- LEDs D3-D6, D13, D15 and D19-D20 will blink on and off in a binary sequence, with D13 the MSB and D3 the LSB. The LCD will display “FF” in the right-most two digits.
- The voltage across the two pins of J8 will measure 2.5V +/- 1%.
- The voltage across the two pins of J7 will measure 1.2V +/- 1%.

Step 3. Test DIP Switches SW9 and SW10

Step 3 continues to exercise the digital inputs and outputs of the Platform Manager. Two of the DIP switches are connected to the digital inputs of the Platform Manager. As these DIP switches are turned on or off, the LCD will display two hexadecimal digits corresponding to the values produced by the four bits of each DIP switch.

- One by one, move DIP switches SW9-SW10 from the off/up position to the on/down position, and then back to the off/up position. The LCD will display corresponding hexadecimal characters representing the hexadecimal value of each DIP switch as it is moved. The value will change for each switch setting, as shown in Table 4. Other values may be created by depressing more than one switch at a time.

Table 4. LCD - Hexadecimal Display

LCD Display	SW10-1	SW10-2	SW10-3	SW10-4	SW9-1	SW9-2	SW9-3	SW9-4
FE	off	off	off	off	off	off	off	ON
Fd	off	off	off	off	off	off	ON	off
Fb	off	off	off	off	off	ON	off	off
F7	off	off	off	off	ON	off	off	off
EF	off	off	off	ON	off	off	off	off
dF	off	off	ON	off	off	off	off	off
bF	off	ON	off	off	off	off	off	off
7F	ON	off	off	off	off	off	off	off

Step 4. Test All Segments of the LCD Display

Similar to Step 3, Step 4 also uses digital inputs. In this step, one of the push-buttons which is connected to a digital input causes the LCD controller to display a looping sequence of numbers from 111-FFF. This sequence repeats on the LCD as long as the push-button is depressed.

- Press and hold PB_B_SW2. The LCD display will show a counting sequence from a blank display, through 111, 222, 333 ... FFF, and will repeat. The count may start anywhere in the sequence.

Step 5. Test Two Push-buttons and Trimming/Margining

This step shows the operation of the Closed Loop Trimming, and the ability of the Platform Manager to have different voltage profiles for margining which are selectable on the fly. There are three profiles used for this test. Profile 1 generates the target voltage (e.g., 1.2V) and adjusts the output voltage up by 5%. Profile 2 adjusts the output voltage down by 5%. Pressing either of the push-buttons shown below selects one of the profiles.

- Press and hold push-button PB_A_SW1.
 - The voltage across the 2 pins of J8 will measure approximately 2.625V.
 - The voltage across the 2 pins of J7 will measure approximately 1.26V.
- Release push-button PB_A_SW1.
- Press and hold push-button PB_B_SW2.
 - The voltage across the 2 pins of J8 will measure approximately 2.375V.
 - The voltage across the 2 pins of J7 will measure approximately 1.14V.
- Release push-button PB_B_SW2.

Step 6. Test Push-button S1 for Reset Function

Step 6 illustrates the Platform Manager's ability to sequence through a power-down scenario, and in this case, restart the demo. When push-button S1 is depressed, the DC-DC converter is powered down, followed by the LDO. The sequencer then returns to the beginning of the demo and starts over.

- Move slide pots R19-R20 to the down position (center of the board). Press and release push-button S1. The board will reset and the test will start over.

VID Demo

The Platform Manager Evaluation Board is designed to demonstrate a form of Voltage control by Identification (VID). This demo does not adhere to any specific "standard" VID specification. Rather, it demonstrates a generic type of digital power supply control for the two power supplies on the Platform Manager Evaluation Board. In this demo, the DIP switches are used to set the desired output voltage and to enable or disable the supplies. This demo makes use of the Platform Manager Closed-loop Trim/Fault Logger IP core and a few lines of CPLD and FPGA LogiBuilder code. This design demonstrates the following features:

- Implements closed loop trim on the 2.5V and 1.2V power supplies
- LEDs indicate the status of the LDO and Murata DC-DC power supply enables
- Receives inputs from switches and push-buttons
- A single VID lookup table can be shared between two different power supplies
- Closed-loop Trim/Fault Logger IP configuration

Note: the Fault Logger IP core is not enabled in this demo. For additional information about the Platform Manager IP core, please refer to the [Platform Management Utility Functions IP Core User's Guide](#).

In order to experiment with the VID Demo, the Platform Manager VID device on the board must be reprogrammed with the pre-compiled design file VID_Demo.jed.

Step 1. Download the VID Demo from the Lattice website.

The VID Demo can be downloaded from the [Platform Manager Development Kit page](#) of the Lattice Semiconductor website.

Step 2. Program the Platform Manager with VID_Demo.jed

Connect the USB cable from the computer to the Platform Manager Evaluation Board.

Warning: If your operating system prompts you to install drivers for new hardware – do not install the default USB drivers or you will have difficulty re-programming the Platform Manager device. Stop and install the Lattice USB drivers found in the ispTools folder on your computer.

Open ispVM™ Version 17.9 or later. Scan the JTAG chain (F2) to find the LPTM10-12107 device. Double-click the row to edit the device information. Browse to the VID_Demo.jed to open the file, set the Operation to **Erase, Program, Verify** and click **OK**. Click the **GO** button to start the re-programming. When the Platform Manager is programmed with the VID demo design LED D21 will be blinking on and off with a period of 500ms.

Step 3. Verify the 2.5V LDO VID Operation

Connect a Digital Volt Meter (DVM) to J8 to monitor the LDO output voltage. The voltage should be near zero with LED D24 off after programming, power-up, or reset by momentarily pressing push button S1. Enter the VID setting from Table 5 (SW[4:1]) on switch SW10 and momentarily press push-button PB_B_SW2 to enable the LDO and set the trim target. Only the following VID codes are valid for the LDO: 0, 10, 11, 12, 13, 14, and 15. The VID code of zero will disable the LDO and turn off LED D24. Any other VID will enable the LDO and turn on LED D24. VID table entries 1 to 9 are below the LDO's trim range and will result in an output near 2.38V. This is because the LDO's trim resistor network is designed to support a range of +/- 5% around the LDO's nominal 2.5V output.

Table 5. Common VID Code Lookup Table

VID	SW1	SW2	SW3	SW4	Voltage	VID Table Code
0	0	0	0	0	0.00	0
1	1	0	0	0	1.14	570
2	0	1	0	0	1.16	580
3	1	1	0	0	1.18	590
4	0	0	1	0	1.19	595
5	1	0	1	0	1.20	600
6	0	1	1	0	1.21	605
7	1	1	1	0	1.22	610
8	0	0	0	1	1.24	620
9	1	0	0	1	1.26	630
10	0	1	0	1	2.40	1200
11	1	1	0	1	2.45	1225
12	0	0	1	1	2.50	1250
13	1	0	1	1	2.55	1275
14	0	1	1	1	2.60	1300
15	1	1	1	1	2.62	1310

Note: 0 = switch in the down position; 1 = switch in the up position.

Step 4. Verify the 1.2V Murata DC-DC Module VID Operation

Move the DVM to J7 to monitor the Murata DC-DC module output voltage. The measured voltage should be about 0.23V with LED D23 off after programming, power-up, or reset by momentarily pressing push button S1. Enter the VID setting from Table 5 (SW[4:1]) on switch SW9 and momentarily press-push button PB_A_SW1 to enable the DC-DC module and set the trim target. Only VID codes from 0 to 9 are valid for the DC-DC module. The VID code of zero will disable the DC-DC module and turn off LED D23. Any other VID will enable the DC-DC module and turn on LED D23. VID table entries 10 and above exceed the DC-DC module's trim range and will result in an output near 1.27V. This is because the trim resistor network is designed to support a range of +/- 5% around the DC-DC module's nominal 1.2V output. In Table 5, more VID codes are allocated to the DC-DC module to provide finer adjustment of the lower voltage power supply. The VID Table Codes represent the closed loop trim ADC target value and is generated from the IP configuration dialog.

Board Hardware Features

LED Outputs – CPLD

The Platform Manager Evaluation Board has four LEDs tied to the CPLD open-drain outputs. The LEDs are pulled up to 3.3V and are lit when OUT6 through OUT9 are driven to a logic low.

Figure 3. CPLD LEDs

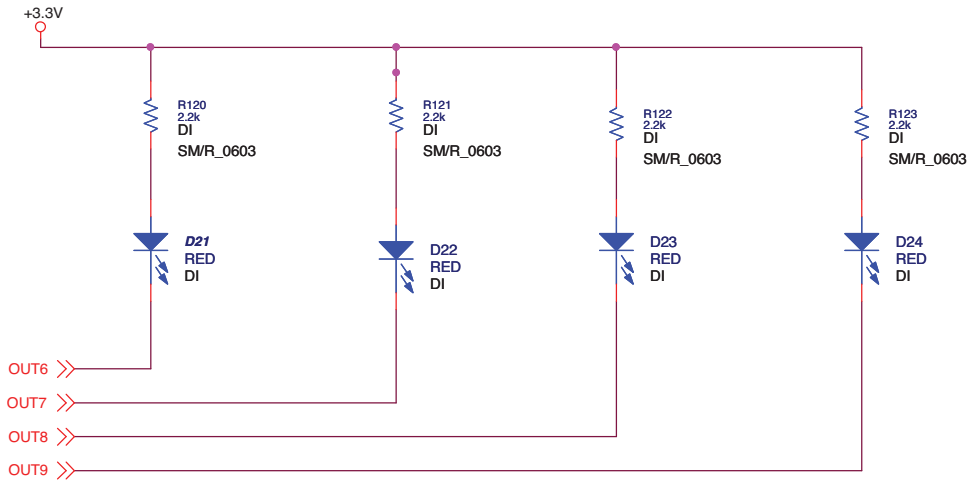

LED Outputs – FPGA

The eight FPGA LEDs are tied to Bank0 of the FPGA pins. They are pulled up to 3.3V and the LEDs are lit when the outputs are driven with a logic low.

Figure 4. FPGA LEDs

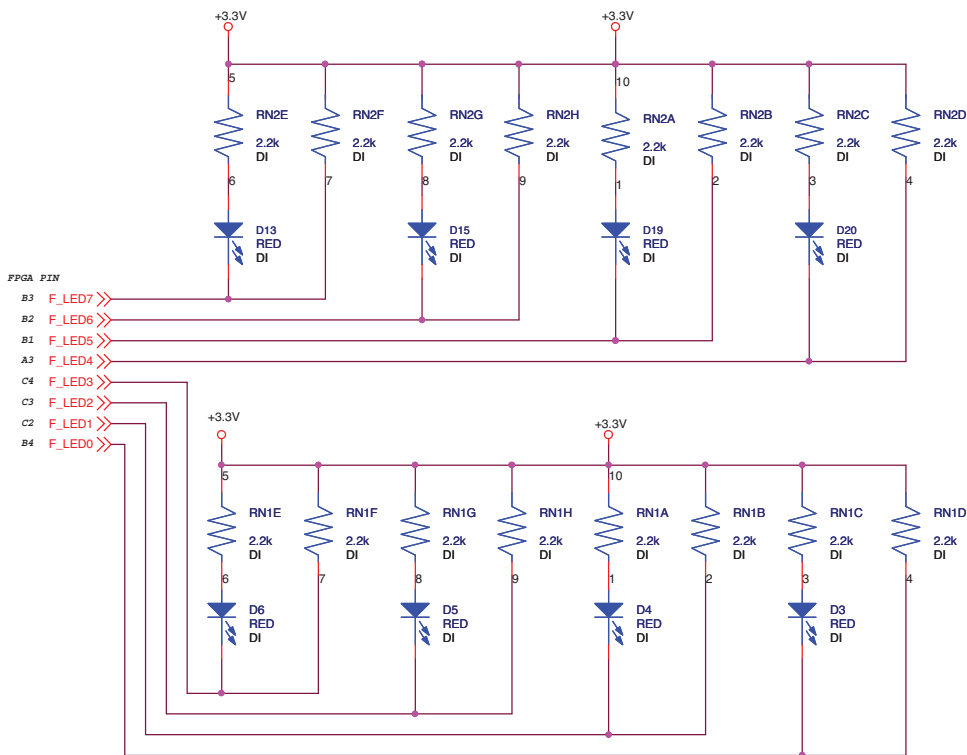

Open-Drain CPLD Outputs

There are 16 available outputs for the CPLD. These include four HVOUT pins and 12 3.3V open-drain outputs. The outputs are set up to drive four LEDs for the CPLD, four Fault Logging outputs or general purpose signals to the FPGA, SMBUS Alert and the OUT16_Timer signal. OUT11 and OUT12 are used for enables to the user supplies. OUT16_Timer drives an FPGA clock input for slow clocks and long timers in the FPGA. OUT16 time base is calculated automatically in PAC-Designer and depends on the time delay chosen by the user in the FTimer blocks.

Figure 5. Open-Drain CPLD Outputs

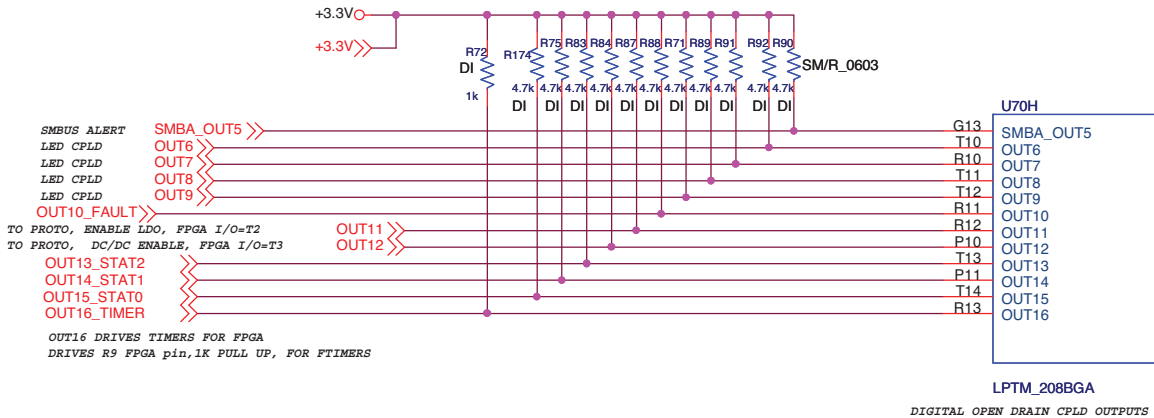

I/O Expansion Header

The Platform Manager Evaluation Board has an unpopulated 32 pin-header for access to I/O signals for the FPGA. These connections are labeled on the board. This allows users to develop custom designs and expand the I/O count for the board

Figure 6. I/O Expansion Header

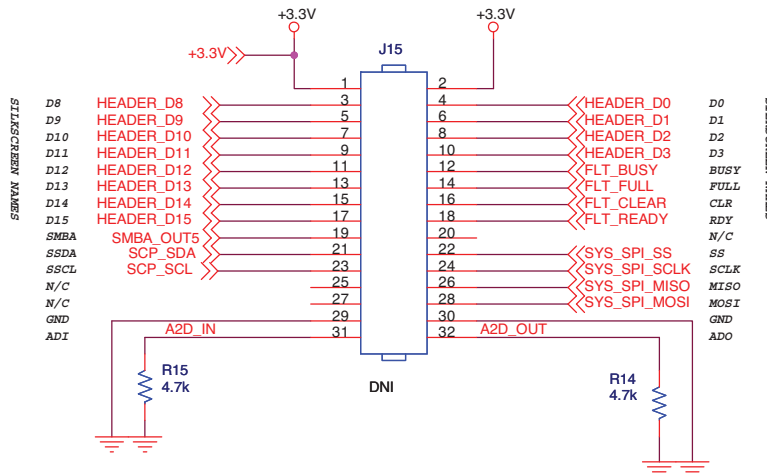

The interface has generic I/Os, SPI control signals, I²C control and fault logging signals. All of these can be set up and programmed by the user for custom I/Os.

LCD Display

The LCD provided is driven by FPGA outputs. The LCD is a set of three 7-segment displays. For more information on LCD usage, see the description of the Platform Manager Demo earlier in this document.

Figure 7. LCD Display

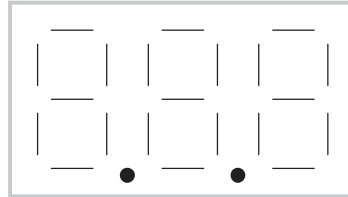

LCD NO BACKLIGHT: DRIVE WITH FPGA OUTPUTS WITH PHASE CONTROL TO LIGHT SEGMENTS

Part# LCD-S301C31TR

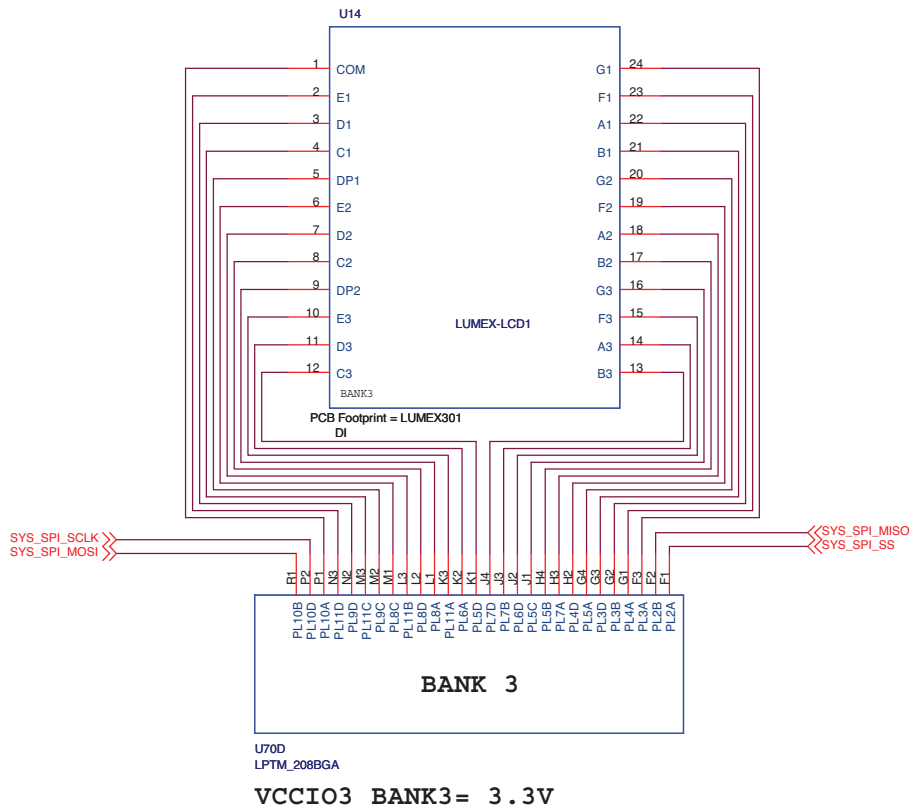

DIP Switches

The Platform Manager Evaluation Board provides eight DIP switches that are connected to the FPGA portion of the Platform Manager device. In addition, there are four DIP switches for JTAG configuration (SW2).

Figure 8. DIP Switches

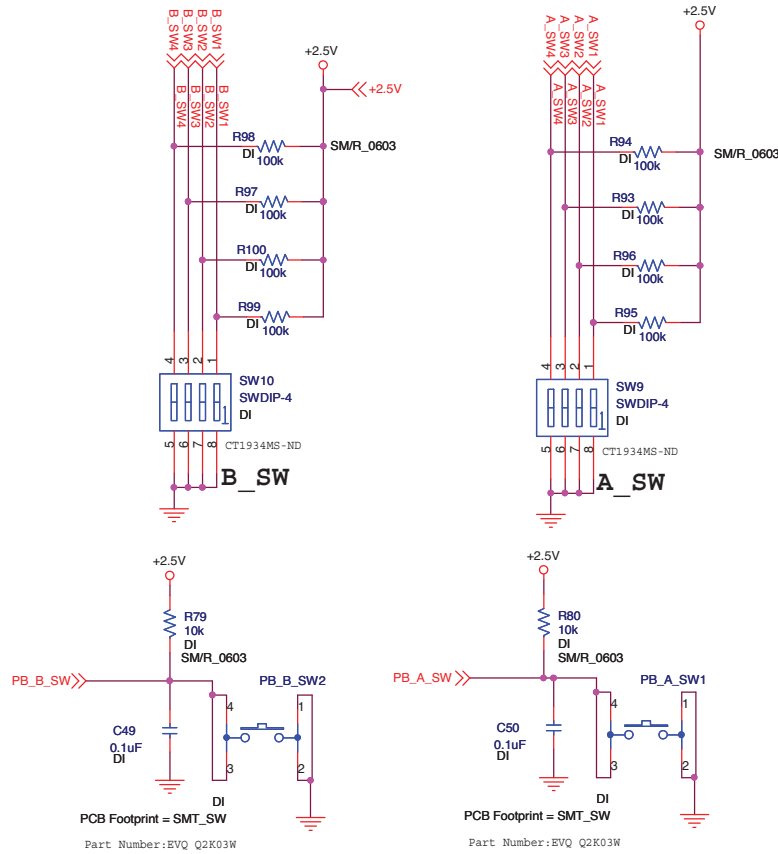

VMON Slide Potentiometers

The two potentiometers are tied to VMON8 and VMON9; these can be used to simulate a fault or to trip a comparator to turn on or off a display or power supply. The voltage on the potentiometer can also be read out from the A/D converter using the I²C port.

Figure 9. VMON Slide Potentiometers

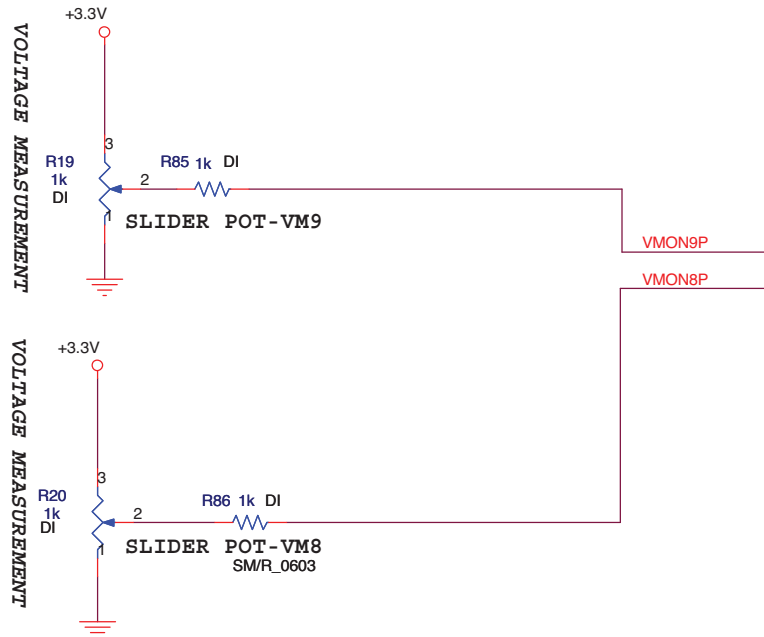

HVOUT MOSFET Ramp Circuits

HVOUTs are used for driving N-channel MOSFETs. HVOUT1 and HVOUT2 are tied to MOSFETs mounted on the evaluation board. Each HVOUT can be set for a different drive current to show voltage ramps at the source of the FET. Note that HVOUT1 can be monitored on VMON1P and HVOUT2 can be monitored on VMON2.

HVOUT3 and HVOUT4 are routed to the prototype area for off-board use.

Figure 10. HVOUT MOSFET Ramp Circuits

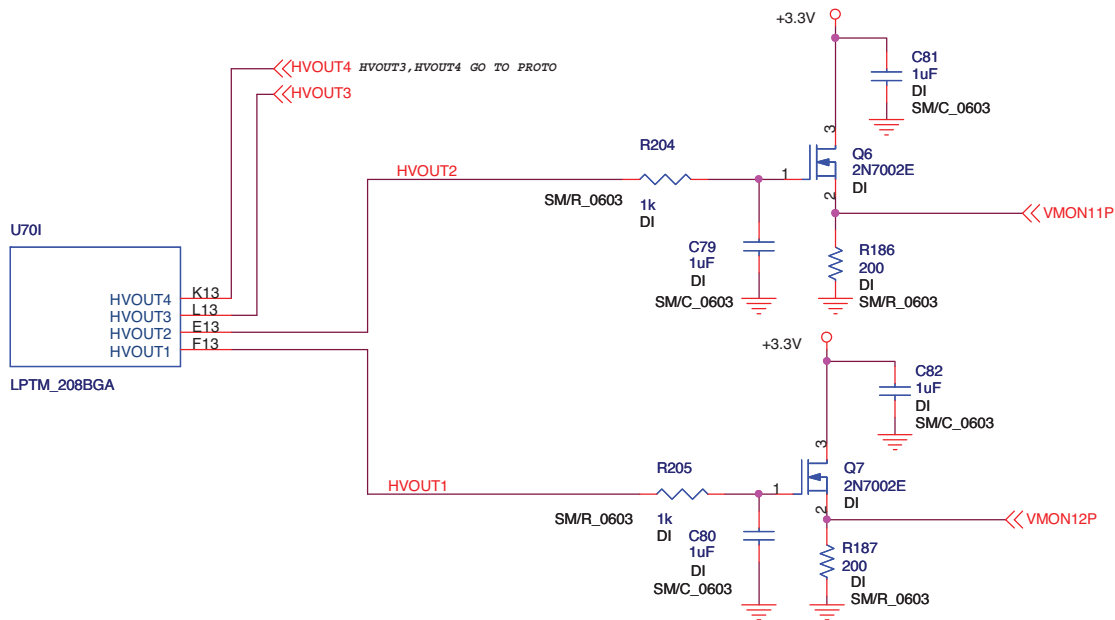

HVOUT1, HVOUT2 drivers do not sequence on board power, they demonstrate a ramp circuit, controlled by PAC Designer settings and visible on a scope. FETS are 250mA max!

VMON Voltage Monitor Inputs

There are 12 VMON inputs to the analog section of the device. These are routed to board power supplies, user power supplies, the temperature sensing circuits, slider pots and the prototype area. All VMONs voltages can be read out from the A/D converter using I²C. The VMONs are described in Table 6.

Table 6. VMON Descriptions

VMON	Description
VMON1	Tied to the prototype area for off-board monitoring or trim applications.
VMON2	Tied to the prototype area for off-board monitoring or trim applications.
VMON3	Monitor for 2.5V power supply used on FPGA Bank1 VCCIO.
VMON4	Monitor for 5V power supply, main wall adapter rail.
VMON5	Voltage monitor for the user DC-DC module supply.
VMON6	Voltage monitor for the user LDO supply.
VMON7	Temperature monitor on the thermistor circuit.
VMON8	Voltage monitor on slide pot R20.
VMON9	Voltage monitor on slide pot R19.
VMON10	Monitor for main 3.3V rail.
VMON11	Voltage monitor for FET ramp circuit and Q6 MOSFET.
VMON12	Voltage monitor for FET ramp circuit and Q7 MOSFET.

Figure 11. Voltage Monitor Inputs

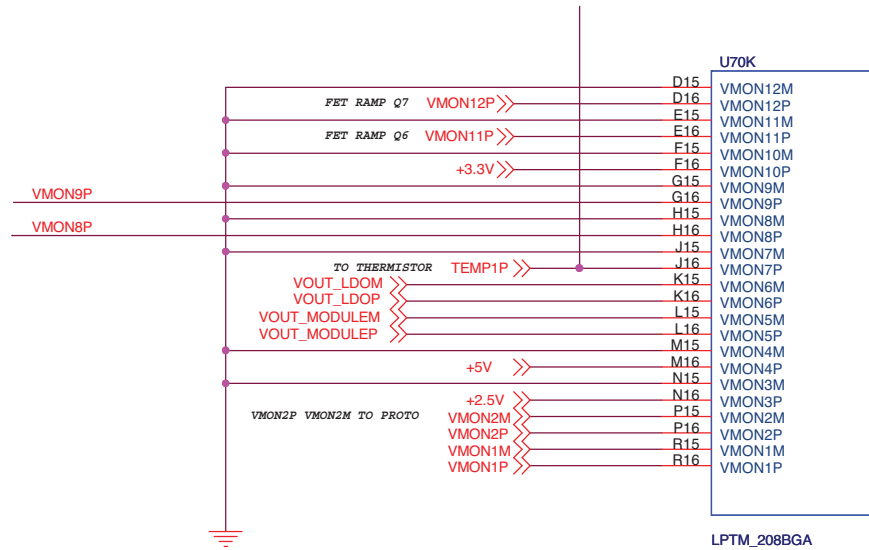

Trim DACs

The Trim DACs are used for margining and trimming power supplies. On the Platform Manager Evaluation Board, the LDO is hooked to TRIM6 and VMON6P/VMON6M. The Murata DC-DC Module is hooked to TRIM5 and VMON5P/VMON5M. These resources provide for closed loop trimming of the supply.

The demo design is set up to trim the LDO to 2.5V and the DC-DC module to 1.2V. Each supply has been biased on the board with resistors for setting the output voltage as well as the resistors required for trimming. If the user would like to select different values, the resistors in the trim network must be changed.

Figure 12. Trim DACs

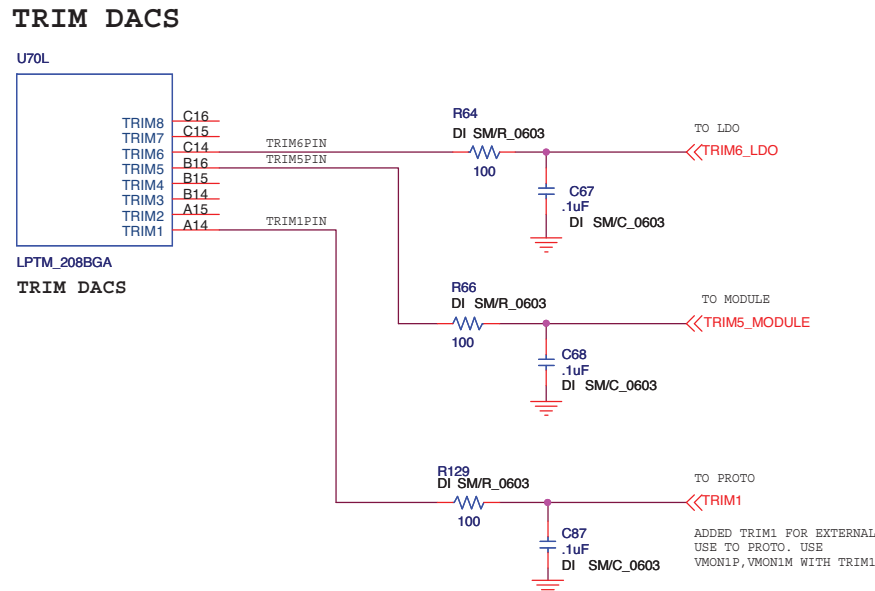

Trimming User Supplies: LDO 2.5V

The trim circuit and LDO user power supply is set up on the board to output 2.5V to the load connectors. Note that in its default configuration, there is a relatively light power load on the evaluation board. Users may add additional

loads to the green screw connectors located at J8. The load should not exceed the maximum ICC of the LDO (1.2A).

Figure 13. LDO 2.5V

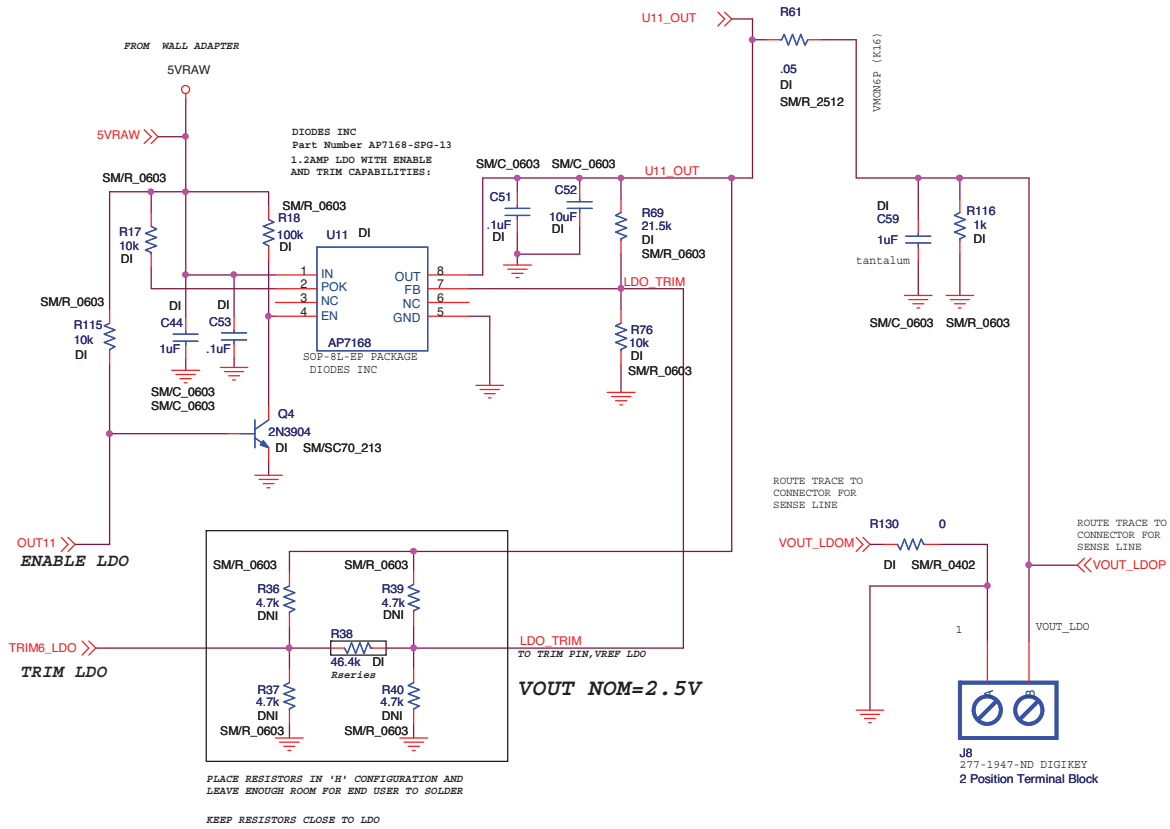

Trimming DC-DC Module

The DC-DC Module (Murata OKR DC-DC Module 1.2V) is set to VOUT=1.2V. The trim network is shown connected to TRIM5_Module in Figure 14. If the user needs to program the supply at a different voltage, the resistors R110, R111, R109, R106 will need to be changed and a new DC-DC macro built within PAC-Designer.

Figure 14. DC-DC Module

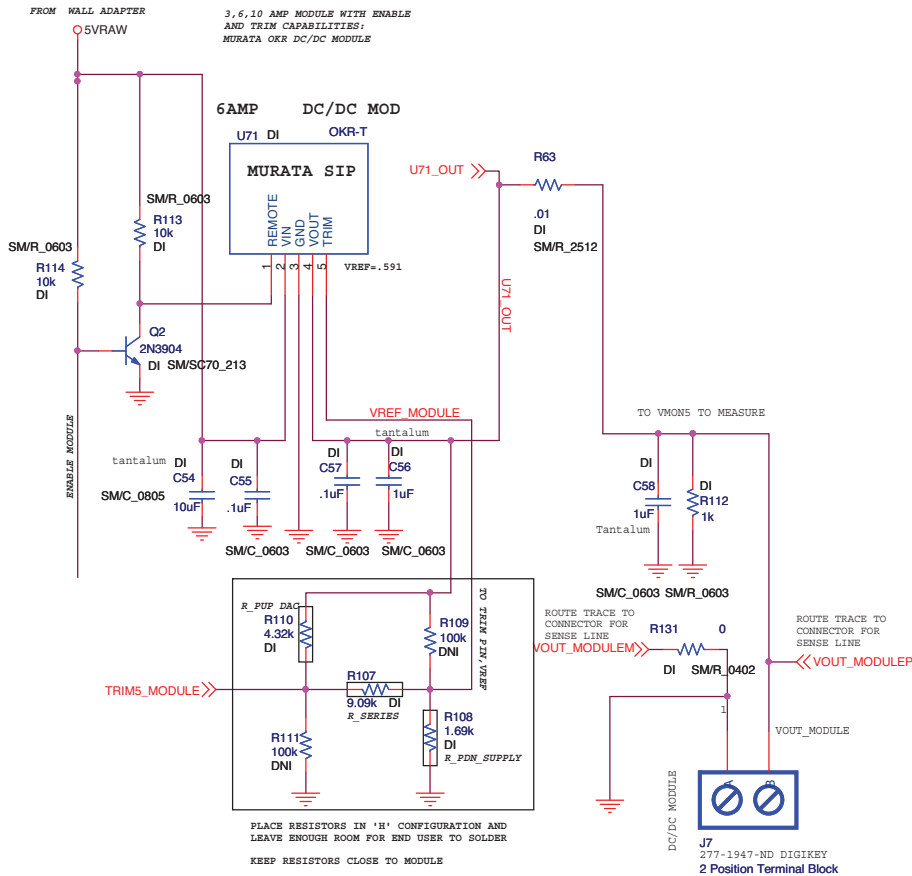

Temperature Monitoring

The board has a thermistor mounted as a voltage divider circuit that is routed to VMON7. This analog input is a standard VMON. The VMONs are used as a programmable comparator, each has two programmable trip points. By setting the trip points in the software, an over-temp can be used to shut down a power supply or light an LED when a certain temperature is read. The VMON can also be set to a window comparator with a high and low trip point. The VMONs can be read out from the A/D converter using I²C.

Figure 15. Temperature Monitoring

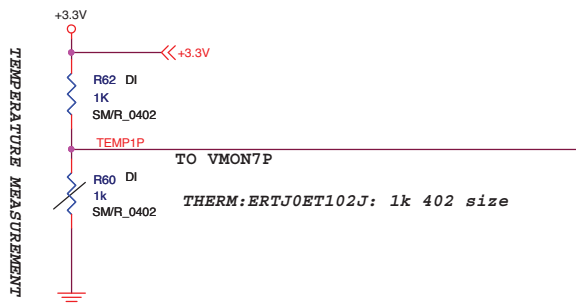

RESET

The evaluation board has one reset push-button. This signal is routed to IN2 of the CPLD. Equations can be written in PAC-Designer for resetting the CPLD sequence. The reset is also routed to the FPGA, where it drives pin F4. Equations must be written to use these pins as a reset function. It is not a full board or chip reset unless the designer sets it up that way.

Figure 16. Reset

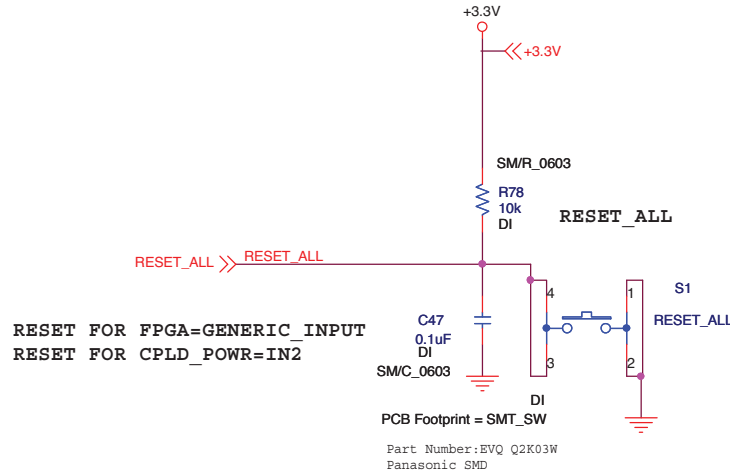

On-board SPI Flash Memory

The Platform Manager Evaluation Board has a 4MBit SPI Flash memory that is used to record faults in the system. Fault logging is accomplished by monitoring the VMON pins and activating an output pin when a power supply falls outside its programmed range. The VMONs have programmable trip points and support a window compare. If the voltage falls outside the window, a fault is triggered. When a fault is triggered, output pins from the CPLD write to the FPGA and are decoded to represent different fault conditions. Once the fault has occurred, the FPGA finds the next available memory page and writes out the data using SPI. The stored data is non-volatile. The board can be powered down and data read back out of the Flash using design utilities. Lattice provides software tools, reference designs and IP cores that work with the Platform Manager Development Kit or designers can use their own designs.

Figure 17. On-Board SPI Flash Memory

4MBIT SPI FLASH MEMORY TO STORE FAULT LOGS CONNECTED TO FPGA
PINS: 2 FOOTPRINT OPTION, POPULATE ONLY ONE

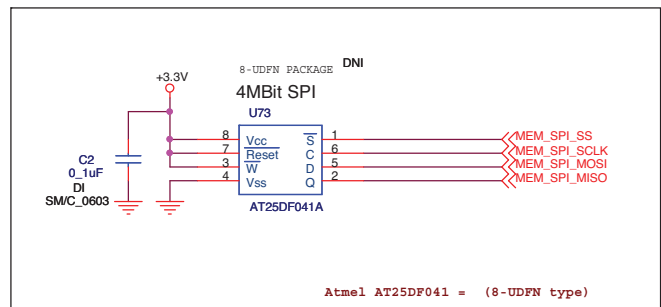
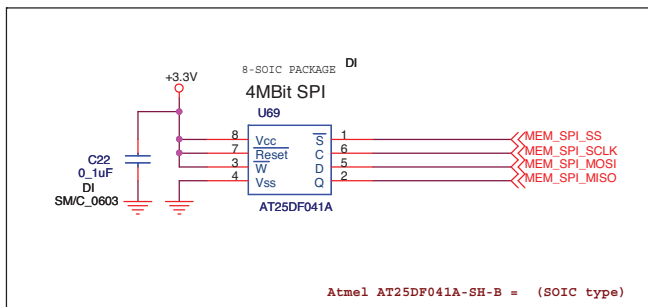

Clock Routing

Table 7. Pin Interconnection for Timers

Package	OUT16 Timer4	Route to	Bank
208-ball ftBGA	OUT16 (R13)	PB9C (R9)	Bank2

To set up additional logic and sequencers in the FPGA in PAC-Designer, the 250kHz CPLDCLK is driven externally and routed to an FPGA pin for a 250kHz clock input. Table 8 shows the connections required for the CPLDCLK, which is externally connected between the dedicated CPLDCLK output pin and an FPGA input pin.

Table 8. Pin Interconnection for CPLDCLK

Package	CPLDCLK	Route to	Bank
208-ball ftBGA	CPLDCLK (C11)	PT6B (D5)	Bank0

Table 9. Pin Interconnection for MCLK

Package	MCLK	Route to	Bank
208-ball ftBGA	MCLK (B11)	PT5B (A2)	Bank0

The 8MHz internal MCLK is also connected externally to the FPGA from the 8MHz MCLK output to an FPGA input. This clock is used for communication and I/O as well as an internal main fabric clock. The Master mode is used to enable the 8MHz internal oscillator.

Figure 18. Clock and Timer Dialog Box

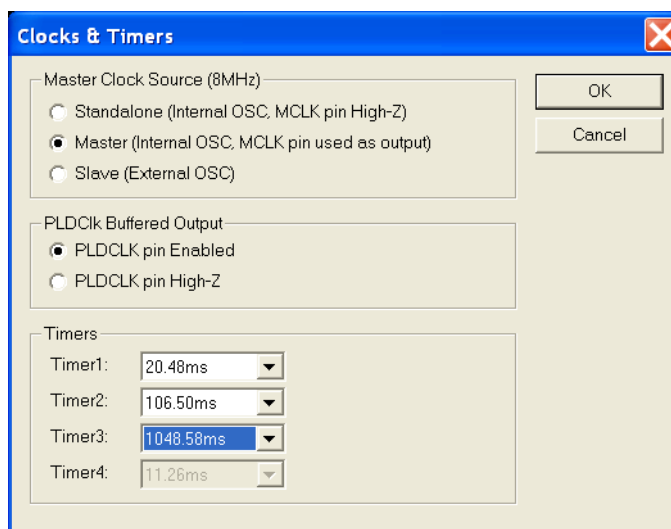

Clock Routing at the Pin

When the design is compiled, PAC-Designer processes the sequencers and synthesizes the logic to be run through fitting and JEDEC generation. These steps are taken care of automatically, once initiated. A report file and a Verilog file are saved in the directory tree structure.

Routing

When using the FPGA clocks and timers, it is important to understand the routing of the pins and the clocks required. In PAC-Designer software, the 8MHz internal clock must be set up for driving to the outside pins and connected externally from pin to pin. The 250kHz PLDCLK is also used externally.

Figure 19. External Connections for Clocks

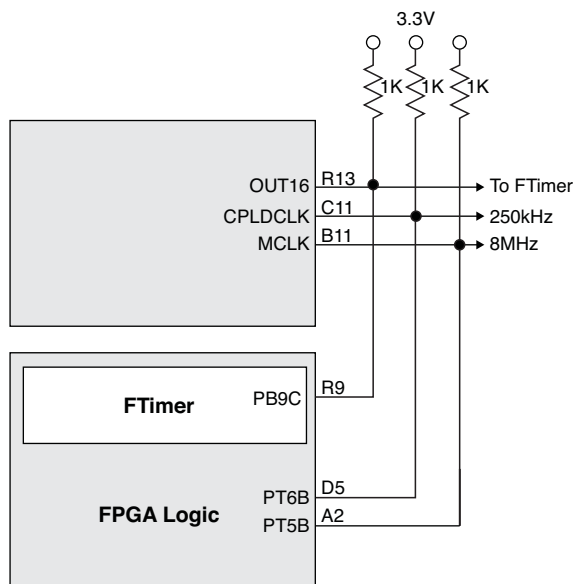

External Connections for 208-Ball ftBGA
CPLD Logic and CLK Outputs

Ordering Information

Description	Ordering Part Number	China RoHS Environment-Friendly Use Period (EFUP)
Platform Manager Development Kit	LPTM10-12107-DEV-EVN	

Technical Support Assistance

Hotline: 1-800-LATTICE (North America)
 +1-503-268-8001 (Outside North America)
 e-mail: techsupport@latticesemi.com
 Internet: www.latticesemi.com

Revision History

Date	Version	Change Summary
October 2010	01.0	Initial release.
October 2010	01.1	Added Appendix C, Configuring the ispMACH 4000 Mux for the Platform Manager Development Kit.
December 2010	01.2	Added VID Demo text section.

© 2010 Lattice Semiconductor Corp. All Lattice trademarks, registered trademarks, patents, and disclaimers are as listed at www.latticesemi.com/legal. All other brand or product names are trademarks or registered trademarks of their respective holders. The specifications and information herein are subject to change without notice.

Appendix A. Schematic

Figure 20. Mux

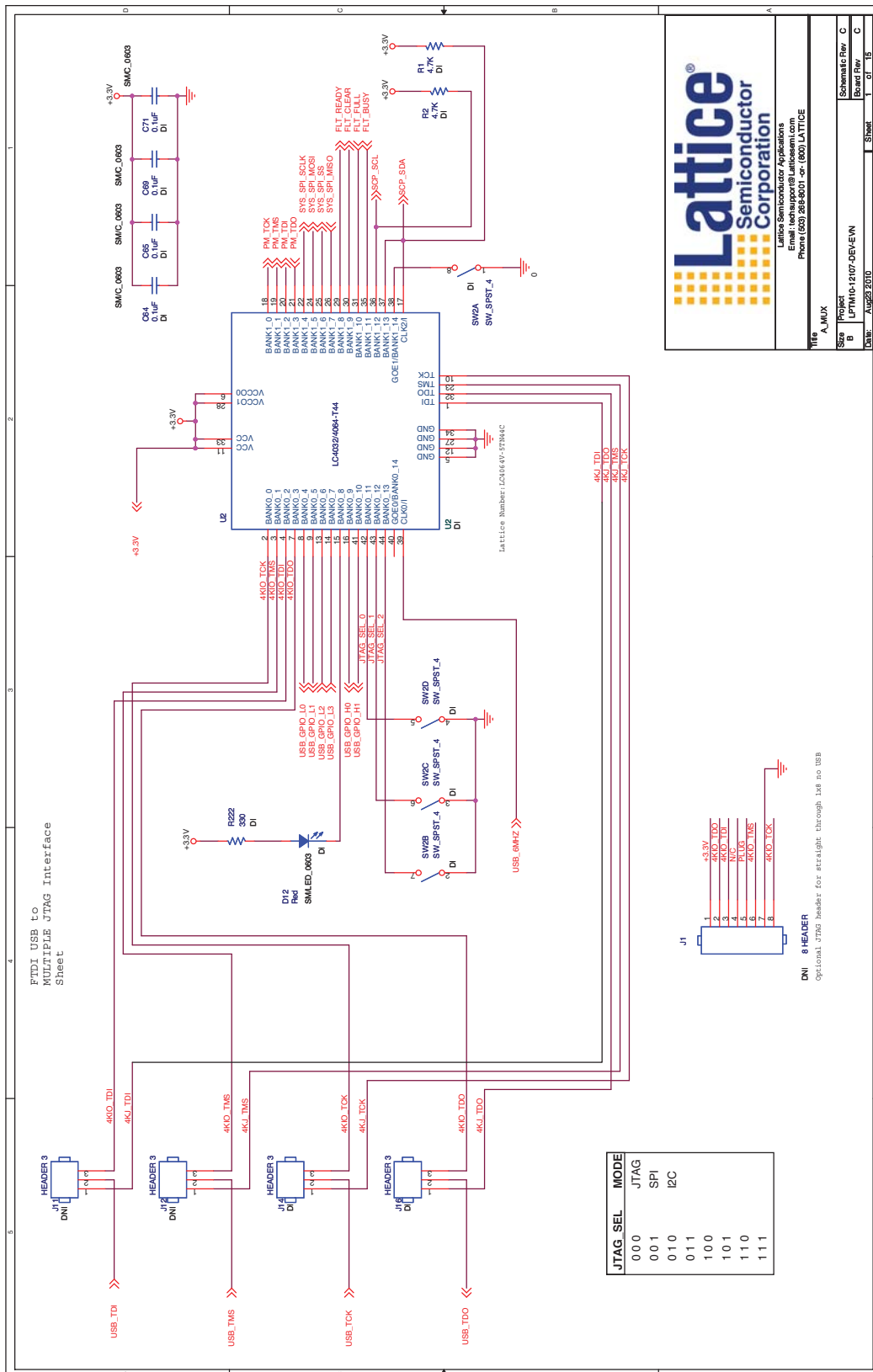

Lattice Semiconductor Corporation
 Lattice Semiconductor Corporation
 Email: techsupport@latticesemi.com
 Phone: (503) 288-8001 or (800) LATTICE

Part: A_MUX
 Project: LPM1M10-12107-061EW
 Schematic Rev: C
 Board Rev: C
 Date: August 2010
 Sheet: 1 of 15

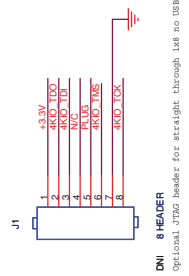

Figure 21. Bank0, Bank3

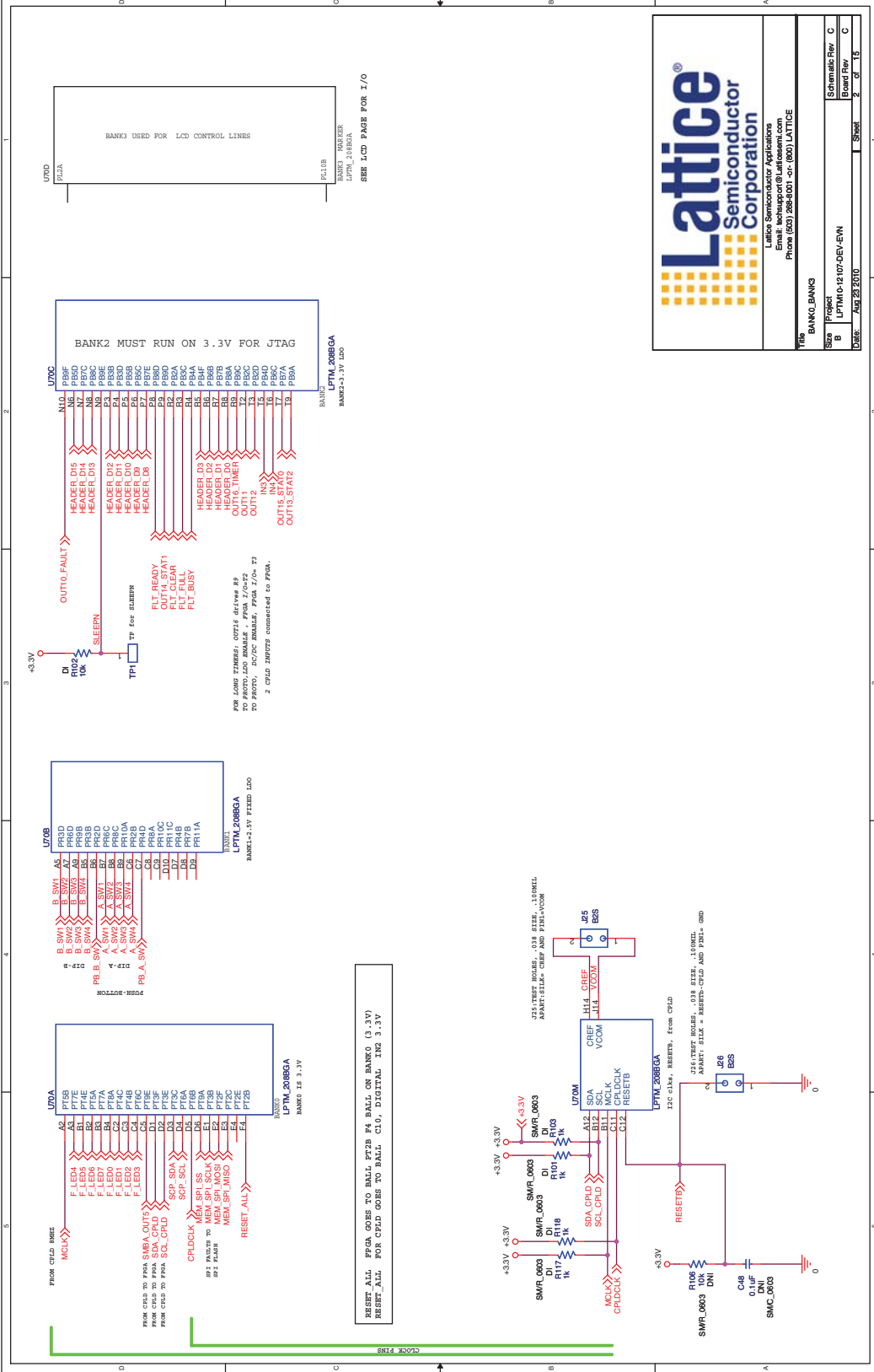
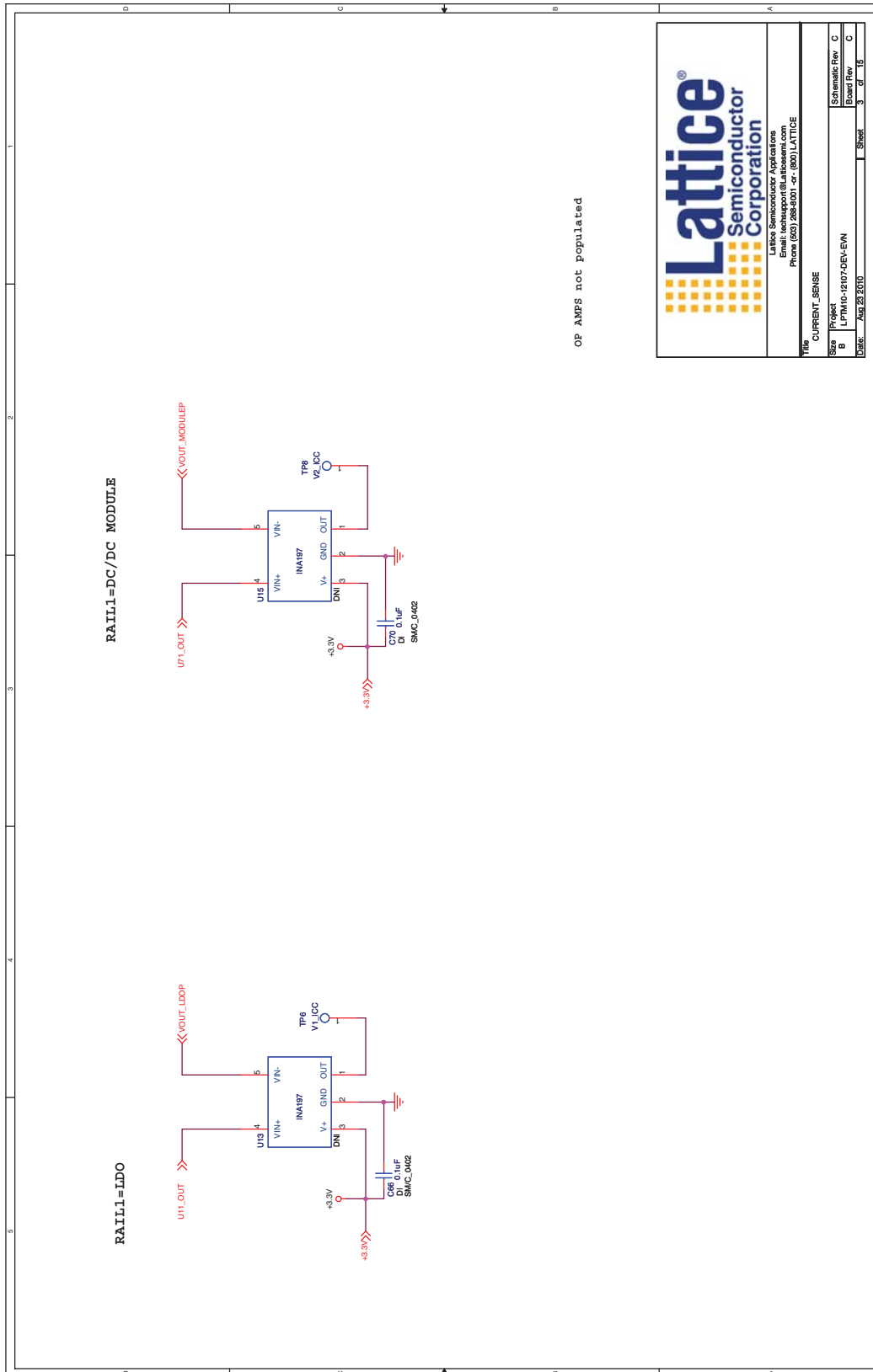

Figure 22. LPTM10-12107-DEC-EVN



Lattice Semiconductor Corporation

Lattice Semiconductor Applications
Engineering Department
Phone (920) 286-5001 ext. (800) LATTICE

FIGURE 22 CURRENT_SENSE

SIZE	Project	Schematic Rev	C
B	LPTM10-12107-DEV-EVN	Board Rev	C
DATE	Aug 28 2010	Sheet	3 of 15

Figure 23. Headers Logo

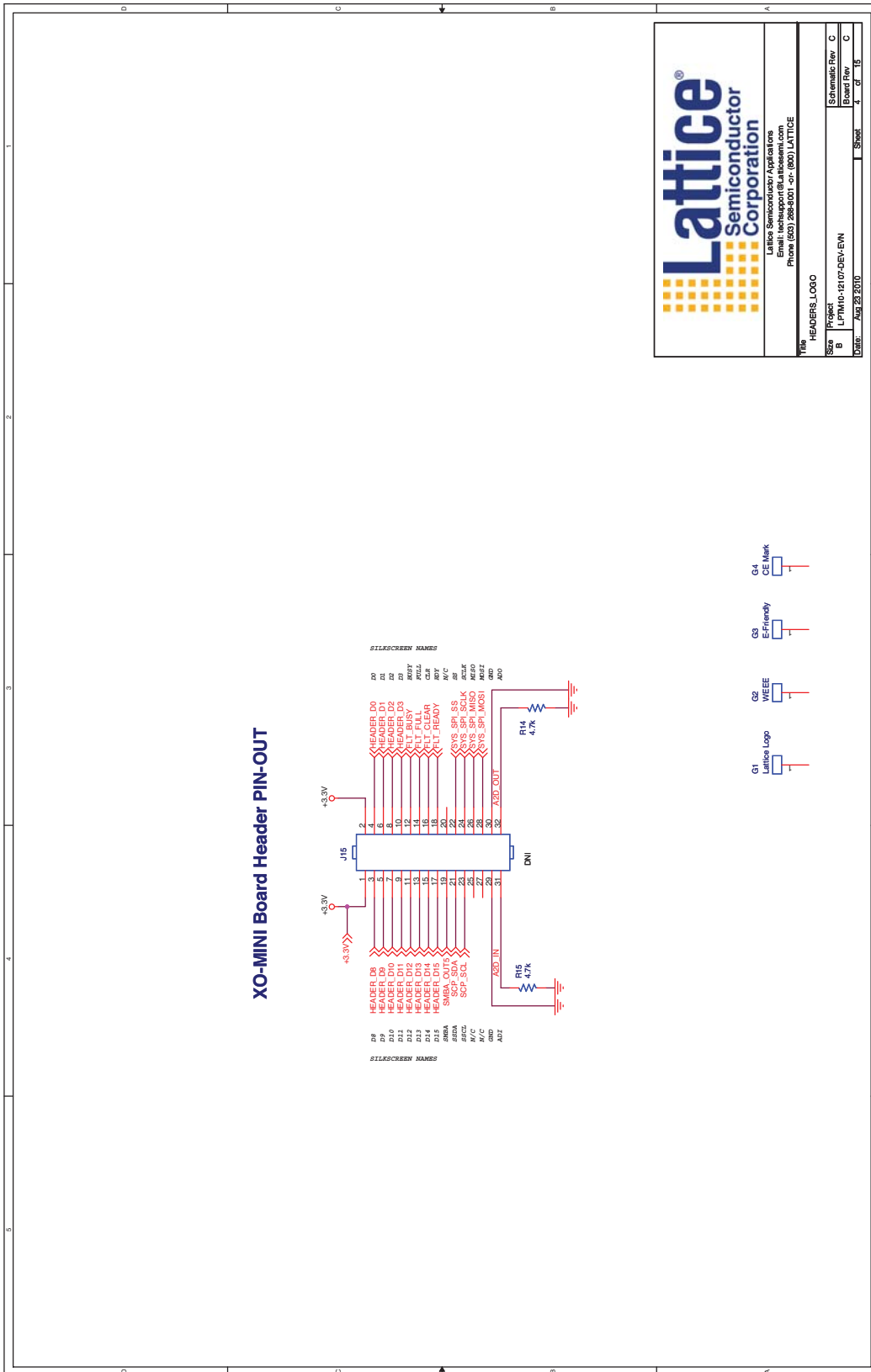

Figure 25. LCD Bank 3

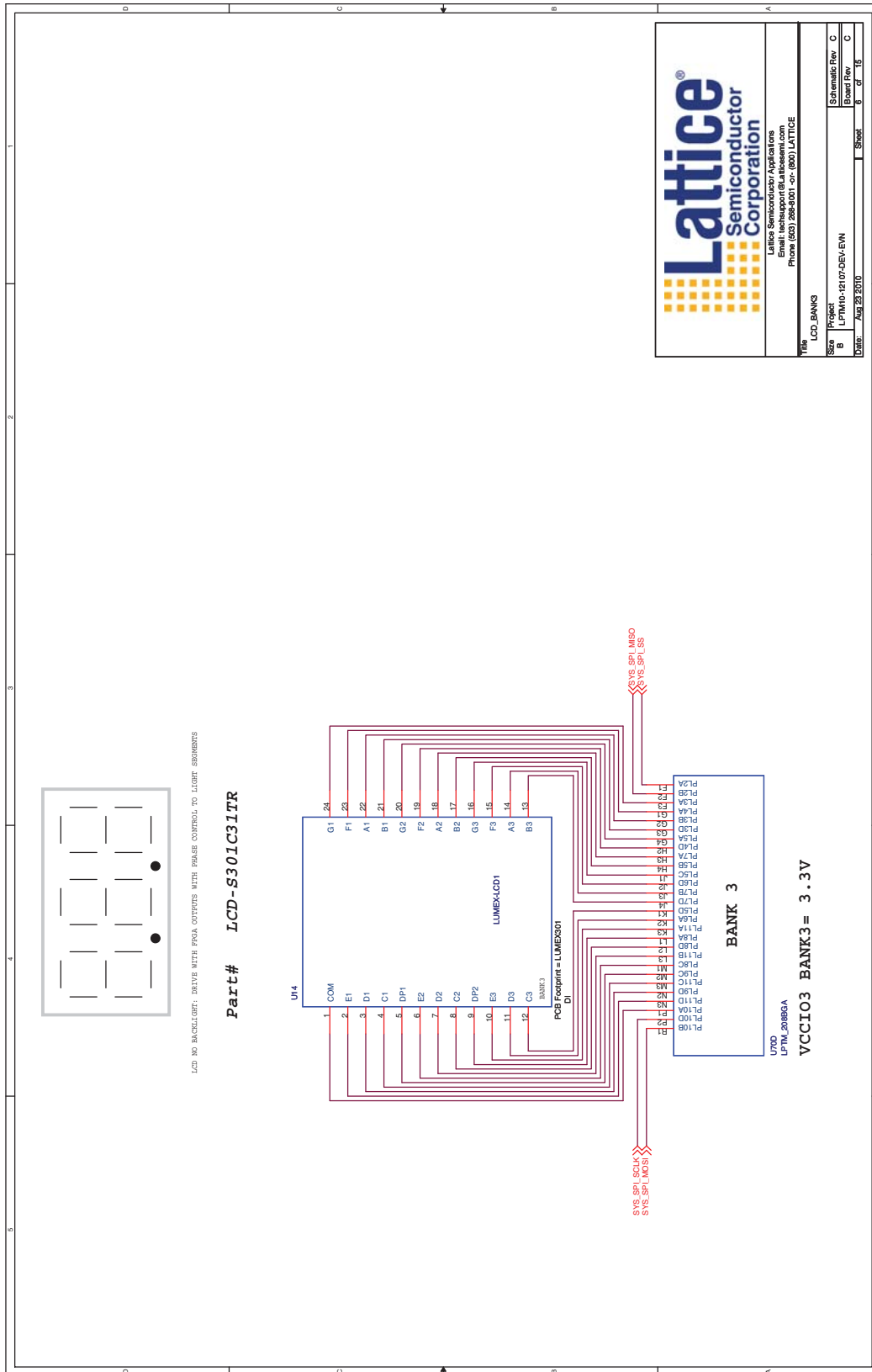

Figure 26. LEDs

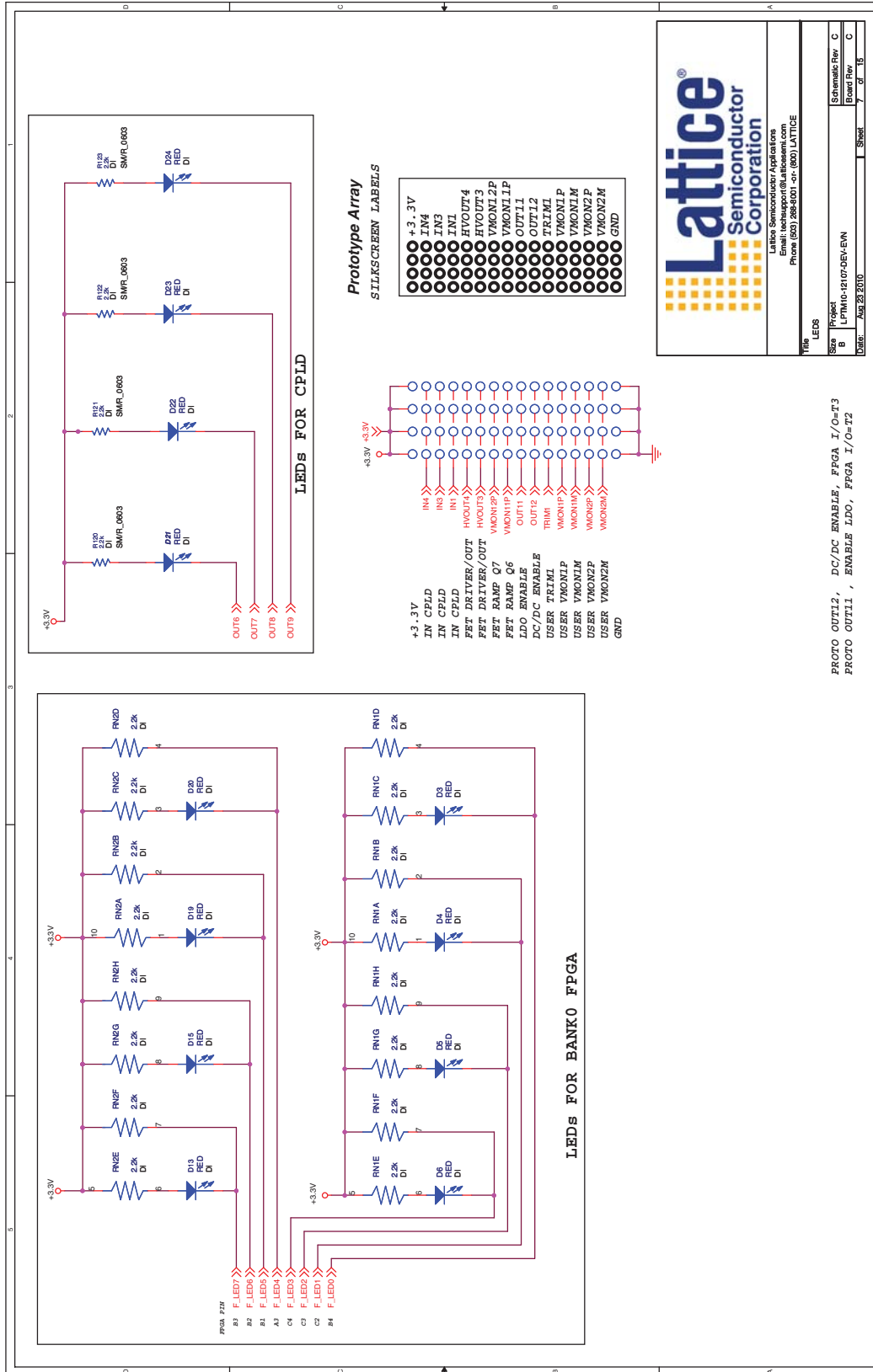
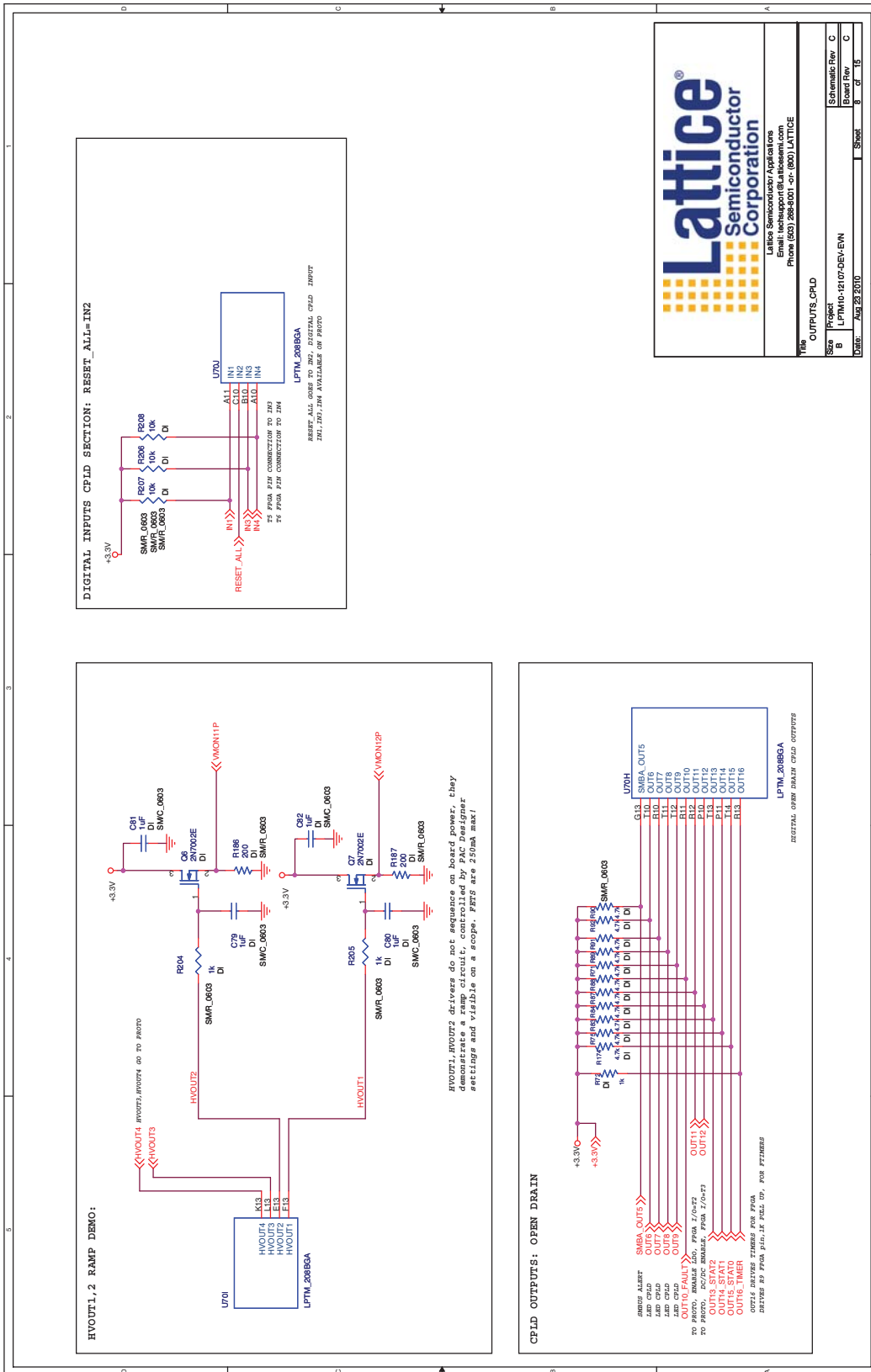

Figure 27. CPLD Outputs



Lattice Semiconductor Corporation

Lattice Semiconductor Applications
Email: platform@lattice.com
Phone: (952) 286-5101 ext. 800 LATTICE

OUTPUTS_CPLD

File	Project	Schematic Rev	C
Size	LPTM10-12107DEV-EVN	Board Rev	C
Date	Aug 28 2010	Sheet	8 of 15

Figure 28. USB Section

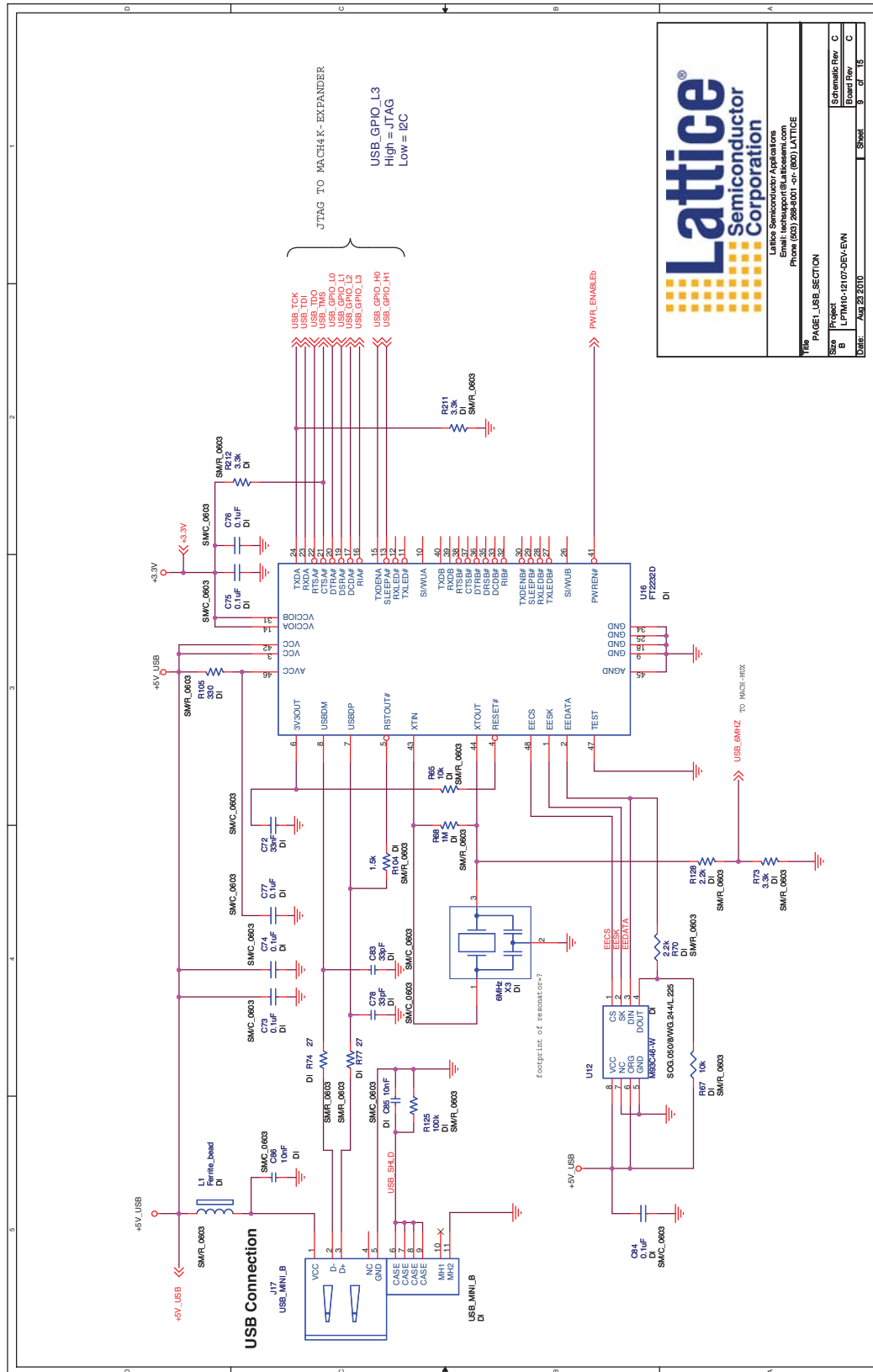

Lattice Semiconductor Corporation
 Lattice Semiconductor Applications
 Email: pmdev@lattice.com
 Phone (US): 28843001 ext. 8001 LATTICE

File	PAGE_USB_SECTION	Schematic Rev	C
Size	LPTM10-12107DEV-EVN	Board Part	C
Date	Aug 28 2010	Sheet	9 of 15

Figure 29. Board Power

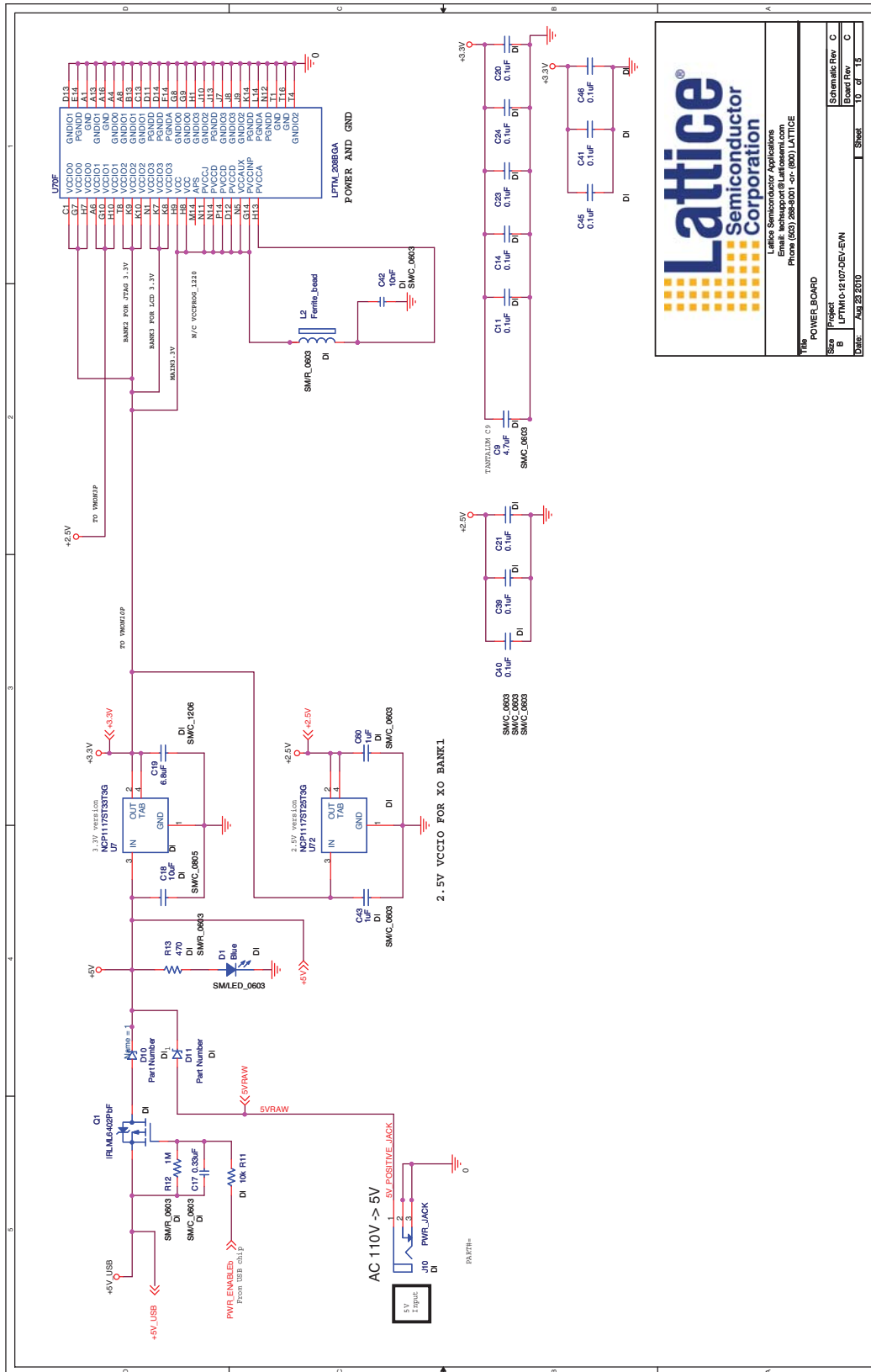

Lattice Semiconductor Corporation

Lattice Semiconductor Applications
Email: platform@lattice.com
Phone: (508) 298-2000 ext. (800) LATTICE

Title	POWERBOARD
Size	Project
Part	LPTM-12107-DEV-EVM
Rev	Rev 1.0
Date	AUG 28 2010
Sheet	10 of 15

Appendix B. Bill of Materials

Table 10. Platform Manager Development Kit Bill of Materials

Item	Quantity	Reference	Part		Manufacturer	Part Number
1	4	Backside PCB mount	Bump-ons	3M Bump-ons	3M	SJ-5003
2	38	C2, C11, C14, C20, C21, C22, C23, C24, C39, C40, C41, C45, C46, C47, C48, C49, C50, C51, C53, C55, C57, C62, C63, C64, C65, C66, C67, C68, C69, C70, C71, C73, C74, C75, C76, C77, C84, C87	0.1uF	0.1uF 0603	Panasonic	ECJ-1VB1C104K
3	1	C9	4.7uF	4.7uF 6.3V	Vishay/Sprague	298D475X06R3M2T
4	1	C17	0.33uF	0.33uF 6.3V	Panasonic-ECG	ECJ-1VB0J334K
5	1	C18	10uF	10uF C0805	Kemet	C0805C106K8PACTU
6	1	C52	10uF	10uF 0603 10uF 6.3V	Panasonic-ECG	ECJ-1VB0J106M
7	1	C54	10uF	10uF Tantalum 0805	Nichicon	F920J106MPA
8	1	C18	10uF C0805	10uF C0805	Kemet	C0805C106K8PACTU
9	1	C19	6.8uF	6.8uF C1206	Kemet	C1206C685K8RACTU
10	3	C42, C85, C86	10nF	10nF	AVX	06035C103KAT2A
11	10	C43, C44, C56, C58, C59, C60, C79, C80, C81, C82	1uF	1uF	Panasonic-ECG	ECJ-1VB1C105K
12	1	C72	33nF	33nF 0603	Panasonic-ECG	ECJ-1VB1C333K
13	2	C78,C83	33pF	33pF 0603	Panasonic-ECG	ECJ-ZEC1E330J
14	1	D1	Blue	LED Blue SMD 0603	Lite-ON	LTST-C190TBKT
15	13	D3, D4, D5, D6, D12, D13, D15, D19, D20, D21, D22, D23, D24	Red	LED Red SMD 0603	Lite-ON	LTST-C190CKT
16	2	D10, D11	Schottky	Scottky diode	ON Semiconductor	MBRS320T3G
17	1	J7	Terminal Block for VMOD	Screw terminal 2 pins each	Phoenix Contacts	1727010
18	1	J8	Terminal Block for VLDO	Screw terminal 2 pins each	Phoenix Contacts	1727010
19	1	J10	PWR_JACK	PWR_JACK 5Vsize	CUI Inc	PJ-102B
20	2	J14, J16	Header 3	3 pin .100" header	Tyco	3-644456-3
21	1	J17	USB_MINI_B	USB_MINI_B	Hirose Electric Co., Ltd.	UX60-MB-5ST
22	2	L1, L2	Ferrite_bead	Ferrite_bead	Steward	HI0603P600R-10
23	3	S1, PB_A_SW1, PB_B_SW2	RESET_ALL	RESET_ALL push-button	Panasonic-ECG	EVQ-Q2K03W
24	1	Q1	IRLML6402PbF	IRLML6402PbF	International Rectifier	IRLML6402TRPBF
25	2	Q2, Q4	2N3904	2N3904 NPN transistor	ON Semiconductor	MMBT3904WT1G
26	2	Q6, Q7	2N7002E	2N7002E	NXP Semiconductors	2N7002E, 215
27	2	RN1, RN2	2.2k	2.2k Resistor network	CTS Resistor Products	745C101222JPKDR
28	6	R70, R120, R121, R122, R123, R128	2.2k	2.2k Resistor	Panasonic-ECG	ERJ-3GEYJ222V
29	19	R1, R2, R14, R15, R71, R75, R83, R84, R87, R88, R89, R90, R91, R92, R119, R124, R126, R127, R174	4.7k	4.7k Resistor	Panasonic-ECG	ERJ-3GEYJ472V

Item	Quantity	Reference	Part		Manufacturer	Part Number
30	16	R11, R17, R65, R67, R76, R78, R79, R80, R102, R106, R113, R114, R115, R206, R207, R208	10k	10k Resistor	Panasonic-ECG	ERJ-3GEYJ103V
31	2	R12, R68	1M	1M Resistor	Panasonic-ECG	ERJ-3GEYJ105V
32	1	R13	470	470 Resistor	Panasonic-ECG	ERJ-3GEYJ471V
33	12	R18R93, R94, R95, R96, R97, R98, R99, R100, R109, R111, R125	100k	100k Resistor	Panasonic-ECG	ERJ-3GEYJ104V
34	14	R19, R20, R62, R72, R85, R86, R101, R103, R112, R116, R117, R118, R204, R205	1k	1k Resistor	Panasonic-ECG	ERJ-3GEYJ102V
35	1	R38	46.4k	46.4k size 0603	Panasonic-ECG	ERJ-3EKF4642V
36	1	R61	0.05	0.05	Ohmite	MCS3264R005FER
37	1	R63	0.01	0.01	Bournes	CRA2512-FZ-R010ELF
38	3	R64, R66, R129	100	100 size 0603	Panasonic-ECG	ERJ-3GEYJ101V
39	1	R69	21.5k	21.5k size 0603	Panasonic-ECG	ERJ-3EKF2152V
40	3	R73, R211, R212	3.3k	3.3k size 0603	Panasonic-ECG	ERJ-3EKF3301V
41	2	R74, R77	27	27 size 0603	Panasonic-ECG	ERJ-3GEYJ270V
42	1	R104	1.5k	1.5k size 0603	Panasonic-ECG	ERJ-3GEYJ152V
43	2	R105, R222	330	330 size 0603	Panasonic-ECG	ERJ-3GEYJ330V
44	1	R107	9.09k	9.09k size 0603	Panasonic-ECG	ERJ-3EKF9091V
45	1	R108	1.69k	1.69k size 0603	Panasonic-ECG	ERJ-3EKF1691V
46	1	R110	4.32k	4.32k size 0603	Panasonic-ECG	ERJ-3EKF4321V
47	2	R186, R187	200	200 size 0603	Panasonic-ECG	ERJ-3EKF2000V
48	1	SW2	SW_SPST_4	SW_SPST_4	CTS Electrocom- ponents	219-4MST
49	2	SW9, SW10	SWDIP-4	SWDIP-4	CTS Electrocom- ponents	193-4MS
50	2	R19, R20	1K POT	Slider Pot	Alpha	RA2043F-20-10EB1-B1K
51	1	U11	AP7168	LDO Regulator	Diodes, Inc.	AP7168-SPG-13
52	1	U12	M93C46-W	M93C46-W (package size)	STMicroelectron- ics	M93C46-WMN6TP
53	1	U14	LUMEX-LCD1	LUMEX-LCD1 (Part # LCD-S301C31TR)	Lumex	LCD-S301C31TR
54	1	U16	FT2232D	USB chip	Future Technology Devices Interna- tional	FT2232D R
55	1	U72	NCP1117ST25T3G	2.5V REG	ON Semiconductor	NCP1117ST25T3G
56	1	U7	NCP1117ST33T3G	3.3V REG	ON Semiconductor	NCP1117ST33T3G
57	1	X3	6MHz	6MHz ceramic resonator	Murata	CSTCR6M00G53-R0
58	2	R1, R2	4.7k	4.7k	Panasonic-ECG	ERJ-3GEYJ472V
59	1	R60	1K	1K Thermistor 0402 size	Panasonic-ECG	ERTJ0ET102J
60	1	U2	LC4032/4064-T44	ispMACH®	Lattice Semiconductor	LC4032/4064-T44
61	1	U70	LPTM_208BGA	BGA 208 LPTM10-12107	Lattice Semiconductor	LPTM10-12107-3FTG208C
62	1	U71	OKR-T	DC-DC	Murata	OKR-T
63	1	U69	Flash	AT25DF041A-SH-B	Atmel	AT25DF041A-SH-B

Appendix C. Configuring the ispMACH 4000 Mux for the Platform Manager Development Kit

The Platform Manager Evaluation Board is programmed with a standard USB cable interface. In order to download to the Lattice devices on the board, the USB signals are converted to JTAG with an FTDI device (FT2232D, U16). There are several interfaces used on the board. In addition to the JTAG interface, there is an I²C interface and a SPI interface. These signals are controlled with a mux that is programmed into the ispMACH 4064 device (LC4032/4064-T44, U2). The ispMACH 4064 controls the mode of communication for the data written to and read from the Platform Manager device. The mux is pre-programmed during assembly and the demo pattern is also pre-programmed into the Platform Manager devices. Users do not need to re-program the mux as it is used for the data and clocks in the three different modes. The mode select lines are controlled with a DIP switch. If the mux is accidentally re-programmed or if a user needs to add special code, the steps to program the device are listed below.

Re-programming the Mux

1. Place a shorting jumper on pins 1 and 2 on J14.
2. Place a shorting jumper on pins 1 and 2 on J16.
3. Attach the USB cable.
4. Open Lattice ispVM System programming software.
5. Perform a Scan operation by clicking on the green **Scan** icon in the toolbar. The device will appear as a JTAG NOP (see Figure 34).

Figure 34. Device Information Dialog

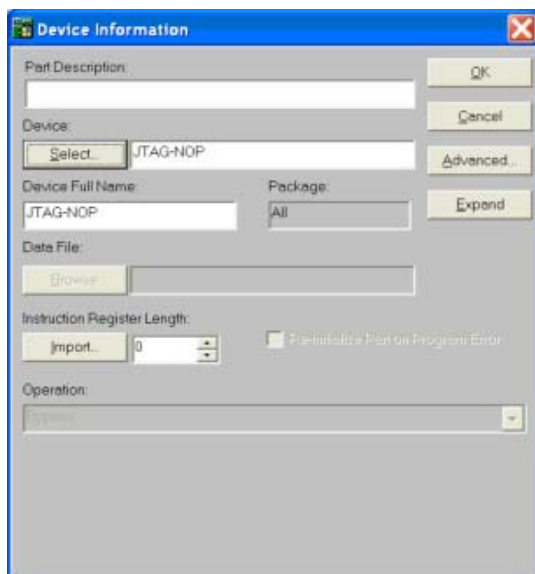

6. Double-click on the **Device Select** button. Scroll to the **ispMACH 4000** Device Family selection. Select **LC4064V(B)-32IO** for the Device and click **OK**. See Figure 35.

Figure 35. Select Device Dialog

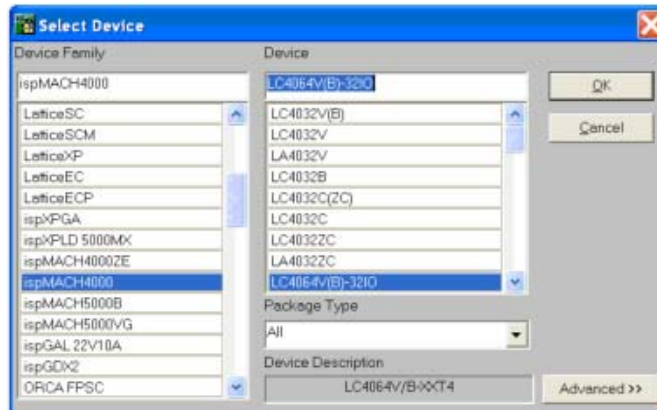

- Click **Browse** and point to the location of the JEDEC file. The file name for the MUX is **pm_4k_mux.jed** (see Figure 36). After selecting the path, click **OK**.

Figure 36. Browse to JEDEC File Path

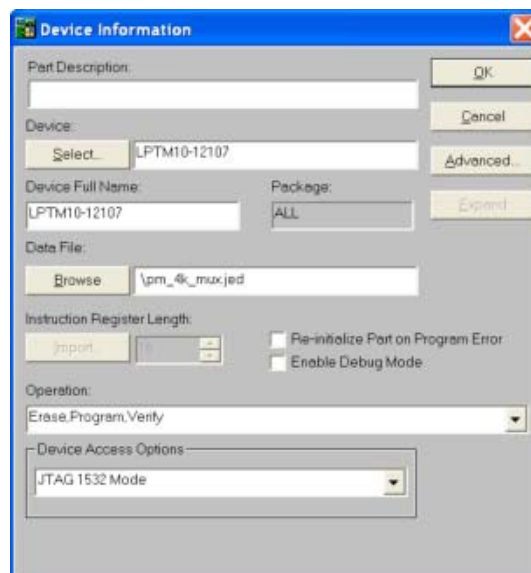

- From the toolbar, select **Project Settings > Project**. There are two selections that need to be made:
 - Check the **Disable JTAG Header Connection Tests** check-box
 - Check the **Continue Download Even on Error** check-box

Click **OK**. See Figures 37 and 38.

Figure 37. Project Settings on the Toolbar

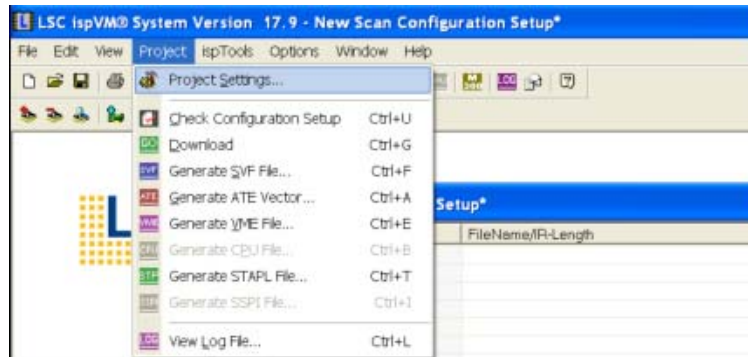
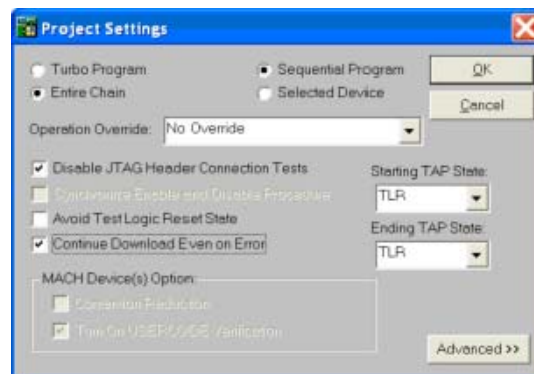

Figure 38. Project Settings Dialog Box



9. The device is now ready to program. Click the **GO** icon on the toolbar to program.

You must remove the jumpers for any further operations to work properly.

Now that the mux has the proper program, access to the rest of the circuitry such as the Platform Manager device and Flash memory is restored.

The following files are associated with the mux:

- pm_4k_mux.SYN
- pm_4k_mux.v
- pm_4k_mux.JED



Компания «ЭлектроПласт» предлагает заключение долгосрочных отношений при поставках импортных электронных компонентов на взаимовыгодных условиях!

Наши преимущества:

- Оперативные поставки широкого спектра электронных компонентов отечественного и импортного производства напрямую от производителей и с крупнейших мировых складов;
- Поставка более 17-ти миллионов наименований электронных компонентов;
- Поставка сложных, дефицитных, либо снятых с производства позиций;
- Оперативные сроки поставки под заказ (от 5 рабочих дней);
- Экспресс доставка в любую точку России;
- Техническая поддержка проекта, помощь в подборе аналогов, поставка прототипов;
- Система менеджмента качества сертифицирована по Международному стандарту ISO 9001;
- Лицензия ФСБ на осуществление работ с использованием сведений, составляющих государственную тайну;
- Поставка специализированных компонентов (Xilinx, Altera, Analog Devices, Intersil, Interpoint, Microsemi, Aeroflex, Peregrine, Syfer, Eurofarad, Texas Instrument, Miteq, Cobham, E2V, MA-COM, Hittite, Mini-Circuits, General Dynamics и др.);

Помимо этого, одним из направлений компании «ЭлектроПласт» является направление «Источники питания». Мы предлагаем Вам помощь Конструкторского отдела:

- Подбор оптимального решения, техническое обоснование при выборе компонента;
- Подбор аналогов;
- Консультации по применению компонента;
- Поставка образцов и прототипов;
- Техническая поддержка проекта;
- Защита от снятия компонента с производства.



Как с нами связаться

Телефон: 8 (812) 309 58 32 (многоканальный)

Факс: 8 (812) 320-02-42

Электронная почта: org@eplast1.ru

Адрес: 198099, г. Санкт-Петербург, ул. Калинина, дом 2, корпус 4, литера А.