

HCPL-2730/0730/2731/0731

Dual Channel Low Input Current, High Gain Optocouplers



Data Sheet



Description

These dual channel optocouplers contain a separated pair of GaAsP light emitting diodes optically coupled to a pair of integrated high gain photo detectors. They provide extremely high current transfer ratio and excellent input-output common mode transient immunity. A separate pin for the photodiodes and first gain stages (V_{CC}) permits lower output saturation voltage and higher speed operation than possible with conventional photodarlington type optocouplers. In addition, V_{CC} may be as low as 1.6V without adversely affecting the parametric performance.

These dual channel optocouplers are available in an 8-Pin DIP and in an industry standard SO-8 package. The following is a cross reference table listing the 8-Pin DIP part number and the electrically equivalent SOIC-8 part number.

8-Pin DIP	SO-8
HCPL-2730	HCPL-0730
HCPL-2731	HCPL-0731

The SO-8 does not require “through holes” in a PCB. This package occupies approximately one-third the footprint area of the standard dual-in-line package. The lead profile is designed to be compatible with standard surface mount processes.

Functional Diagram

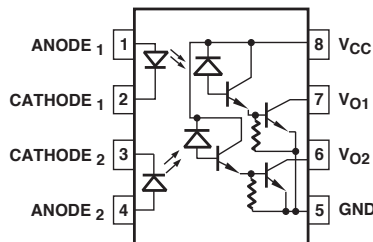

LED	V_O
ON	LOW
OFF	HIGH

A 0.1 μ F bypass capacitor connected between pins 5 and 8 is recommended.

Features

- High current transfer ratio – 1800% typical
- Low input current requirements – 0.5 mA
- Low output saturation voltage – 0.1 V
- High density packaging
- Performance guaranteed over temperature 0°C to 70°C
- LSTTL compatible
- High output current – 60 mA
- Safety approval:
 UL recognized – 3750 V rms for 1 minute and 5000 V rms* for 1 minute
 CSA approved
- Available in 8 pin DIP and SO-8 footprint
- MIL-PRF-38534 hermetic version available (HCPL-5730/5731)
- Surface mount gull wing option available for 8-pin DIP (Option 300)

Applications

- Digital logic ground isolation
- Telephone ring detector
- Level shifting
- EIA RS-232C line receiver
- Polarity sensing
- Low input current line receiver – long line or party line
- Microprocessor bus isolation
- Current loop receiver
- Line voltage status indicator – low input power dissipation

*5000 V rms/1 minute withstand voltage rating is for Option 020 (HCPL-2730, HCLP-2731) products only.

CAUTION: It is advised that normal static precautions be taken in handling and assembly of this component to prevent damage and/or degradation which may be induced by ESD.

Guaranteed operation at low input currents and the high current transfer ratio (CTR) reduce the magnitude and effects of CTR degradation.

The outstanding high temperature performance of this split Darlington type output amplifier results from the inclusion of an integrated emitter-base bypass resistor which shunts photodiode and first stage leakage currents to ground.

The HCPL-2731/0731 have a 400% minimum CTR at an input current of only 0.5 mA making it ideal for use in low input current applications such as MOS, CMOS, and low power logic interfacing or RS232C data transmission systems. In addition, the high CTR and high output current capability make

this device extremely useful in applications where a high fanout is required. Compatibility with high voltage CMOS logic systems is guaranteed by the $18V_{CC}$ and V_o specifications and by testing output high leakage (I_{OH}) at 18 V.

The HCPL-2730/0730 are specified at an input current of 1.6 mA and have a 7 V V_{CC} and V_o rating. The 300% minimum CTR allows TTL to TTL interfacing at this input current.

Important specifications such as CTR, leakage current, and output saturation voltage are guaranteed over the 0°C to 70°C temperature range to allow trouble-free system operation. Selection for lower input currents down to 250 μ A is available upon request.

Selection Guide

8-Pin DIP (300 Mil)		Small Outline SO-8		Widebody Package (400 mil)	Minimum Input ON Current (I_p)	Minimum CTR	Absolute Maximum V_{CC}	Hermetic
Single Channel Package	Dual Channel Package HCPL-	Single Channel Package HCPL-	Dual Channel Package HCPL-	Single Channel Package				Single and Dual Channel Packages HCPL-
6N139 ^[1]	2731	0701 ^[1]	0731	HCNW139 ^[1]	0.5 mA	400%	18 V	
6N138 ^[1]	2730	0700 ^[1]	0730	HCNW138 ^[1]	1.6 mA	300%	7 V	
HCPL-4701 ^[1]	4731 ^[1]	070A ^[1]	073A ^[1]		40 μ A	800%	18 V	
					0.5 mA	300%	20 V	5701 ^[1] 5700 ^[1] 5731 ^[1] 5730 ^[1]

Note:

1. Technical data are on separate Avago publications.

Ordering Information

HCPL-2730, HCPL-2731, HCPL-0730 and HCPL-0731 are UL Recognized with 3750 Vrms for 1 minute per UL1577 and are approved under CSA Component Acceptance Notice #5, File CA 88324.

Part number	Option		Package	Surface Mount	Gull Wing	Tape & Reel	UL 5000 Vrms/ 1 Minute rating	IEC/EN/DIN EN 60747-5-2	Quantity
	RoHS Compliant	Non RoHS Compliant							
HCPL-2730 HCPL-2731	-000E	No option	300mil DIP-8						50 per tube
	-300E	-300		X	X				50 per tube
	-500E	-500		X	X	X			1000 per reel
	-020E	-020					X		50 per tube
	-320E	-320		X	X		X		50 per tube
	-520E	-520		X	X	X	X		1000 per reel
	-060E	-060						X	50 per tube
	-360E	-360		X	X			X	50 per tube
	-560E	-560		X	X	X		X	1000 per reel
	HCPL-0730 HCPL-0731	-000E		No option	50-8				
-500E		-500	X	X		X			1500 per reel
-060E		-060						X	100 per tube
-560E		-560	X	X		X		X	1500 per reel

To order, choose a part number from the part number column and combine with the desired option from the option column to form an order entry.

Example 1:

HCPL-2730-520E to order product of 300mil DIP Gull Wing Surface Mount package in Tape and Reel packaging with UL 5kVrms 1minute rating in RoHS compliant.

Example 2:

HCPL-2730 to order product of 300mil DIP package in tube packaging and non RoHS compliant.

Option datasheets are available. Contact your Avago sales representative or authorized distributor for information.

Remarks: The notation '#XXX' is used for existing products, while (new) products launched since 15th July 2001 and RoHS compliant option will use '-XXxE'.

Schematic



USE OF A 0.1 μ F BYPASS CAPACITOR CONNECTED BETWEEN PINS 5 AND 8 IS RECOMMENDED (SEE NOTE 8)

Package Outline Drawings

8-Pin DIP Package (HCPL-2731/HCPL-2730)



DIMENSIONS IN MILLIMETERS AND (INCHES).
 *MARKING CODE LETTER FOR OPTION NUMBERS
 "L" = OPTION 020
 OPTION NUMBERS 300 AND 500 NOT MARKED.

NOTE: FLOATING LEAD PROTRUSION IS 0.25 mm (10 mils) MAX.

8-Pin DIP Package with Gull Wing Surface Mount Option 300 (HCPL-2731/HCPL-2730)



Small Outline SO-8 Package (HCPL-0731/HCPL-0730)

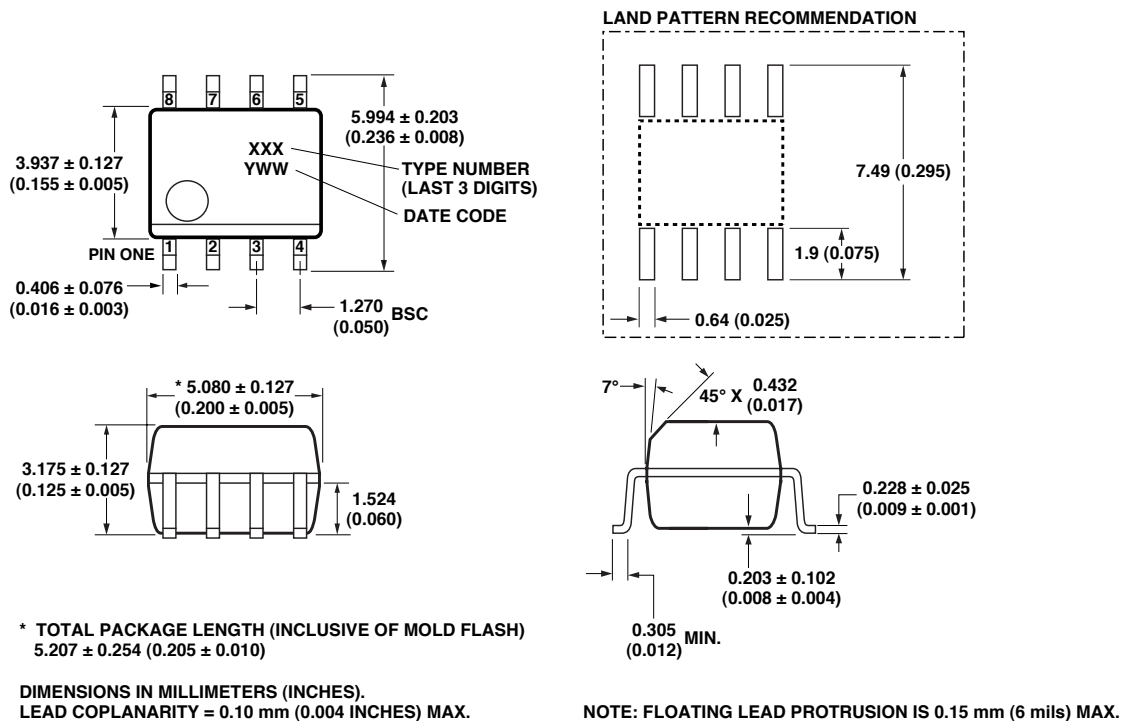

Solder Reflow Thermal Profile



Note: Non-halide flux should be used.

Recommended Pb-Free IR Profile

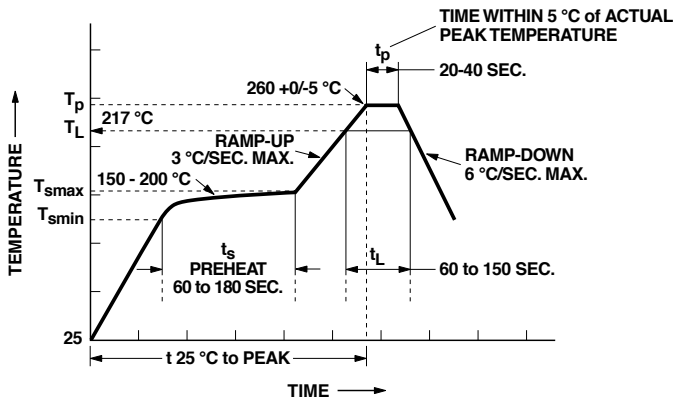

NOTES:
 THE TIME FROM 25 °C to PEAK TEMPERATURE = 8 MINUTES MAX.
 $T_{smax} = 200^{\circ}\text{C}$, $T_{smin} = 150^{\circ}\text{C}$

Note: Non-halide flux should be used.

Regulatory Information

The HCPL-2731/2730 have been approved by the following organizations:

UL

Recognized under UL 1577, Component Recognition Program, File E55361.

CSA

Approved under CSA Component Acceptance Notice #5, File CA 88324.

IEC/EN/DIN EN 60747-5-2

Approved under
 IEC 60747-5-2:1997 + A1:2002
 EN 60747-5-2:2001 + A1:2002
 DIN EN 60747-5-2 (VDE 0884 Teil 2):2003-01
 (Option 060 only)

Insulation Related Specifications (HCPL-2731/2730/0731/0730)

Parameter	Symbol	8-Pin DIP (300 Mil)	50-8	Units	Conditions
		Value	Value		
Minimum External Air Gap (External Clearance)	L(101)	7.1	4.9	mm	Measured from input terminals to output terminals, shortest distance through air.
Minimum External Tracking (External Creepage)	L(102)	7.4	4.8	mm	Measured from input terminals to output terminals, shortest distance path along body.
Minimum Internal Plastic Gap (Internal Clearance)		0.08	0.08	mm	Through insulation distance, conductor to conductor, usually the direct distance between the photoemitter and photodetector inside the optocoupler cavity.
Tracking Resistance (Comparative Tracking Index)	CTI	200	200	Volts	DIN IEC 112/ VDE 0303 Part 1
Isolation Group		IIIa	IIIa		Material Group DIN VDE 0110

Option 300 – surface mount classification is Class A in accordance with CECC 00802.

IEC/EN/DIN EN 60747-5-2 Insulation Related Characteristics

Description	Symbol	Characteristic	Units
Installation Classification per DIN VDE 0110/1.89, Table 1 for rated mains voltage ≤ 600 V rms		I-IV	
for rated mains voltage ≤ 1000 V rms		I-III	
Climatic Classification		55/100/21	
Pollution Degree (DIN VDE 0110/1.89)		2	
Maximum Working Insulation Voltage	VIORM	1414	V _{peak}
Input to Output Test Voltage, Method b* $V_{PR} = 1.875 \times V_{IORM}$, 100% Production Test with $t_p = 1$ sec, Partial Discharge < 5 pC	VPR	2652	V _{peak}
Input to Output Test Voltage, Method a* $V_{PR} = 1.5 \times V_{IORM}$, Type and Sample Test, $t_p = 60$ sec, Partial Discharge < 5 pC	VPR	2121	V _{peak}
Highest Allowable Overvoltage* (Transient Overvoltage, $t_{ini} = 10$ sec)	VIOTM	8000	V _{peak}
Safety Limiting Values (Maximum values allowed in the event of a failure, also see Figure 11, Thermal Derating curve.)			
Case Temperature	T_S	175	°C
Current (Input Current I_P , $P_S = 0$)	$I_{S,INPUT}$	400	mA
Output Power	$P_{S,OUTPUT}$	700	mW
Insulation Resistance at T_S , $V_{IO} = 500$ V	R_S	$> 10^9$	Ω

*Refer to the front of the optocoupler section of the current catalog, under Product Safety Regulations section, IEC/EN/DIN EN 60747-5-2, for a detailed description.

Note: Isolation characteristics are guaranteed only within the safety maximum ratings which must be ensured by protective circuits in application.

Absolute Maximum Ratings (No Derating Required up to 85°C)

Parameter	Symbol	Min.	Max.	Units
Storage Temperature	T_S	-55	125	°C
Operating Temperature	T_A	-40	85	°C
Average Forward Input Current	$I_{F(AVG)}$		20	mA
Peak Forward Input Current (50% Duty Cycle, 1 ms Pulse Width)	I_{FPK}		40	mA
Reverse Input Voltage (Each Channel)	V_R		5	V
Input Power Dissipation (Each Channel)	P_I		35	mW
Output Current (Each Channel)	I_O		60	mA
Supply Voltage and Output Voltage (HCPL-2731, HCPL-0731) (V_{CC} - Pin 8-5, V_O - Pin 7,6-5) -Note 1	V_{CC}	-0.5	18	V
Supply Voltage and Output Voltage (HCPL-2730, HCPL-0730) (V_{CC} - Pin 8-5, V_O - Pin 7,6-5) -Note 1	V_{CC}	-0.5	7	V
Output Power Dissipation (Each Channel) -Note 12	P_O		100	mW
Total Power Dissipation (Each Channel)	P_T		135	mW
Lead Solder Temperature (for Through Hole Devices)		260°C for 10 sec., 1.6 mm below seating plane		
Reflow Temperature Profile (for SOIC-8 and Option #300)		See Package Outline Drawings section		

Recommended Operating Conditions

Parameter	Symbol	Min.	Max.	Units
Power Supply Voltage (HCPL-2731/HCPL-0731)	V_{CC}	4.5	18	V
Power Supply Voltage (HCPL-2730/HCPL-0730)	V_{CC}	4.5	7	V
Forward Input Current (ON)	$I_{F(ON)}$	0.5	12	mA
Forward Input Voltage (OFF)	$V_{F(OFF)}$	0	0.8	V
Operating Temperature	T_A	0	70	°C

Electrical Specifications

$0^{\circ}\text{C} \leq T_A \leq 70^{\circ}\text{C}$, $4.5\text{ V} \leq V_{CC} \leq 18\text{ V}$, $0.5\text{ mA} \leq I_{F(\text{ON})} \leq 12\text{ mA}$, $0\text{ V} \leq V_{F(\text{OFF})} \leq 0.8\text{ V}$, unless otherwise specified.
All Typicals at $T_A = 25^{\circ}\text{C}$. (See note 8.)

Parameter	Sym.	Device				Units	Test Conditions	Fig.	Note
		HCPL- 2731 0731	Min.	Typ.*	Max.				
Current Transfer Ratio	CTR	2731	400	1800	5000	%	$I_F = 0.5\text{ mA}$ $V_{CC} = 4.5\text{ V}$ $V_O = 0.4\text{ V}$	2, 3	2
		0731	500	1600	2600		$I_F = 1.6\text{ mA}$		
		2730/0730	300	1600	2600		$I_F = 1.6\text{ mA}$		
Logic Low Output Voltage	V_{OL}	2731		0.1	0.4	V	$I_F = 1.6\text{ mA}$, $I_O = 8\text{ mA}$ $V_{CC} = 4.5\text{ V}$	1	
		0731		0.1	0.4		$I_F = 5.0\text{ mA}$, $I_O = 15\text{ mA}$		
				0.2	0.4		$I_F = 12\text{ mA}$, $I_O = 24\text{ mA}$		
		2730/0730		0.1	0.4		$I_F = 1.6\text{ mA}$, $I_O = 4.8\text{ mA}$		
Logic High Output Current	I_{OH}	2731/0731		0.05	100	μA	$V_O = V_{CC} = 18\text{ V}$ $I_F = 0\text{ mA}$	2	
		2730/0731		0.1	250		$V_O = V_{CC} = 7\text{ V}$		
Logic Low Supply Current	I_{CCL}	2731/0731		1.2	3	mA	$V_{CC} = 18\text{ V}$ $I_{F1} = I_{F2} = 1.6\text{ mA}$ $V_{O1} = V_{O2} = \text{Open}$	5	
		2730/0730		0.9			$V_{CC} = 7\text{ V}$		
Logic High Supply Current	I_{CCH}	2731/0731		0.005	20	μA	$V_{CC} = 18\text{ V}$ $I_{F1} = I_{F2} = 0\text{ mA}$, $V_{O1} = V_{O2} = \text{Open}$	5	
		2730/0730		0.004			$V_{CC} = 7\text{ V}$		
Input Forward Voltage	V_F			1.4	1.7	V	$T_A = 25^{\circ}\text{C}$	4	
					1.75		$I_F = 1.6\text{ mA}$		
Input Reverse Breakdown Voltage	BV_R		5.0			V	$I_R = 10\text{ }\mu\text{A}$, $T_A = 25^{\circ}\text{C}$	2	
Temperature Coefficient of Forward Voltage	$\frac{\Delta V_F}{\Delta T_A}$			-1.8		$\text{mV}/^{\circ}\text{C}$	$I_F = 1.6\text{ mA}$		
Input Capacitance	C_{IN}			60		pF	$f = 1\text{ MHz}$, $V_F = 0$	2	

*All typical values at $T_A = 25^{\circ}\text{C}$ and $V_{CC} = 5\text{ V}$, unless otherwise noted.

Switching Specifications (AC)

Over recommended operating conditions ($T_A = 0^\circ\text{C}$ to 70°C), $V_{CC} = 5\text{ V}$, unless otherwise specified.
(See note 8.)

Parameter	Sym.	Device HCPL-	Min.	Typ.*	Max.	Units	Test Conditions	Fig.	Note
Propagation Delay Time to Logic Low at Output	t_{PHL}	2731		25	100	μs	$T_A = 25^\circ\text{C}$	6, 7, 8, 9	2
		0731					$I_F = 0.5\text{ mA}$ $R_I = 4.7\text{ k}\Omega$		
		2730		5	20		$T_A = 25^\circ\text{C}$		
		2731							
		0730 0731				25	$I_F = 1.6\text{ mA}, R_I = 2.2\text{ k}\Omega$		
			0.5	2	3	$T_A = 25^\circ\text{C}$ $I_F = 12\text{ mA}, R_I = 270\ \Omega$			
Propagation Delay Time to Logic High at Output	t_{PLH}	2731		10	60	μs	$T_A = 25^\circ\text{C}$	7, 8, 9	2
		0731					$I_F = 0.5\text{ mA}, R_I = 4.7\text{ k}\Omega$		
		2730		10	35		$T_A = 25^\circ\text{C}$		
		2731							
		0730 0731				50	$I_F = 1.6\text{ mA}, R_I = 2.2\text{ k}\Omega$		
			1	10	15	$T_A = 25^\circ\text{C}$ $I_F = 12\text{ mA}, R_I = 270\ \Omega$			
Common Mode Transient Immunity at Logic High Output	$ CM_H $		1000	10000		$\text{V}/\mu\text{s}$	$I_F = 0\text{ mA}, T_A = 25^\circ\text{C},$ $R_I = 2.2\text{ k}\Omega$ $ V_{\text{CM}} = 10\text{ V}_{\text{p-p}}$	10	2, 6, 7
Common Mode Transient Immunity at Logic Low Level Output	$ CM_L $		1000	10000		$\text{V}/\mu\text{s}$	$I_F = 1.6\text{ mA}, T_A = 25^\circ\text{C},$ $R_I = 2.2\text{ k}\Omega$ $ V_{\text{CM}} = 10\text{ V}_{\text{p-p}}$		

*All typical values at $T_A = 25^\circ\text{C}$ and $V_{CC} = 5\text{ V}$, unless otherwise noted.

Package Characteristics

Parameter	Symbol	Device		Typ.*	Max.	Units	Test Conditions	Fig.	Note
		HCPL-	Min.						
Input-Output Momentary Withstand Voltage**	V_{ISO}		3750			V rms	RH ≤ 50%, t = 1 min., $T_A = 25^\circ\text{C}$		4, 9
		Option 020	2730 2731	5000					4, 10
Resistance (Input-Output)	R_{I-O}			10^{12}		Ω	$V_{I-O} = 500\text{ VDC}$ RH ≤ 45%		4
Capacitance (Input-Output)	C_{I-O}			0.6		pF	f = 1 MHz		11
Input-Input Insulation Leakage Current	I_{I-I}		0.005			μA	RH ≤ 45% $V_{I-I} = 500\text{ VDC}$		5
Input-Input Insulation Leakage Current	R_{I-I}			10^{11}		Ω			5
Capacitance (Input-Input)	C_{I-I}	2730		0.03		pF			5
		2731							
		0730		0.25					
		0731							

*All Typical values at $T_A = 25^\circ\text{C}$ unless otherwise noted.

**The Input-Output Momentary Withstand Voltage is a dielectric voltage rating that should not be interpreted as an input-output continuous voltage rating. For the continuous voltage rating refer to the IEC/EN/DIN EN 60747-5-2 Insulation Characteristics Table (if applicable), your equipment level safety specification or Avago Application Note 1074 entitled "Optocoupler Input-Output Endurance Voltage."

Notes:

- Pin 5 should be the most negative voltage at the detector side.
- Each channel.
- DC CURRENT TRANSFER RATIO (CTR) is defined as the ratio of output collector current, I_{O1} , to the forward LED input current, I_F , times 100%.
- Device considered a two-terminal device: pins 1, 2, 3, and 4 shorted together, and pins 5, 6, 7, and 8 shorted together.
- Measured between pins 1 and 2 shorted together, and pins 3 and 4 shorted together.
- Common mode transient immunity in a Logic High level is the maximum tolerable (positive) dV_{CM}/dt of the common mode pulse, V_{CM} , to assure that the output will remain in a Logic High state (i.e., $V_O > 2.0\text{ V}$). Common mode transient immunity in a Logic Low level is the maximum tolerable (negative) dV_{CM}/dt of the common mode pulse, V_{CM} , to assure that the output will remain in a Logic Low state (i.e., $V_O < 0.8\text{ V}$).
- In applications where dV/dt may exceed $50,000\text{ V}/\mu\text{s}$ (such as static discharge) a series resistor, R_{CC} , should be included to protect the detector IC from destructively high surge currents. The recommended value is $R_{CC} = 110\ \Omega$.
- Use of a $0.1\ \mu\text{F}$ bypass capacitor connected between pins 5 and 8 adjacent to the device is recommended.
- In accordance with UL 1577, each optocoupler is proof tested by applying an insulation test voltage $> 4500\text{ V rms}$ for 1 second (leakage detection current limit, $I_{I-O} < 5\ \mu\text{A}$).
- In accordance with UL 1577, each optocoupler is proof tested by applying an insulation test voltage $> 6000\text{ V rms}$ for 1 second (leakage detection current limit, $I_{I-O} < 5\ \mu\text{A}$).
- Measured between the LED anode and cathode shorted together and pins 5 through 8 shorted together.
- Derate linearly above 65°C free-air temperature at a rate of $2.3\text{ mW}/^\circ\text{C}$ for the SO-8 package.



Figure 1. DC transfer characteristics.



Figure 2. Current transfer ratio vs. forward current.

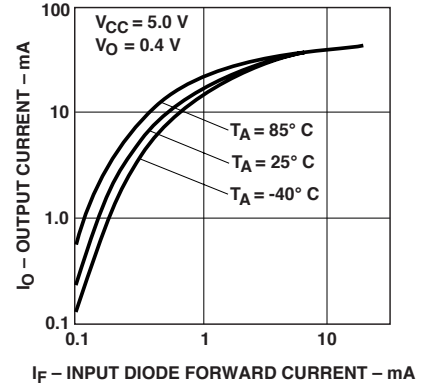

Figure 3. Output current vs. input diode forward current.

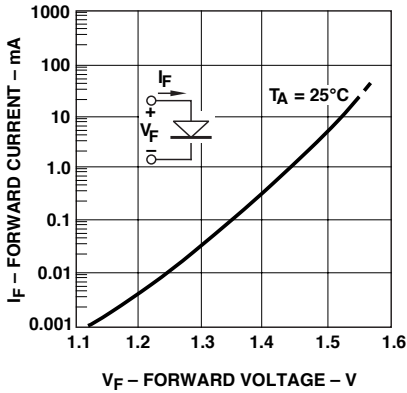

Figure 4. Input diode forward current vs. forward voltage.



Figure 5. Supply current per channel vs. input diode forward current.

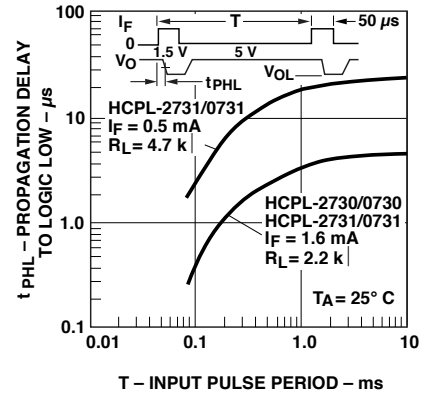

Figure 6. Propagation delay to logic low vs. pulse period.

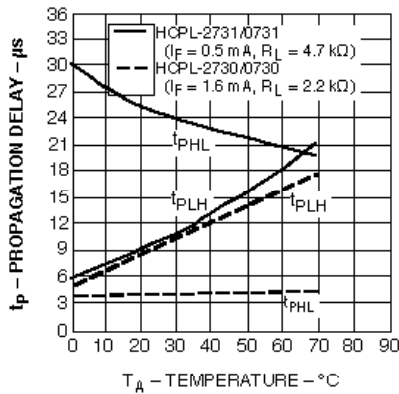

Figure 7. Propagation delay vs. temperature.



Figure 8. Propagation delay vs. input diode forward current.

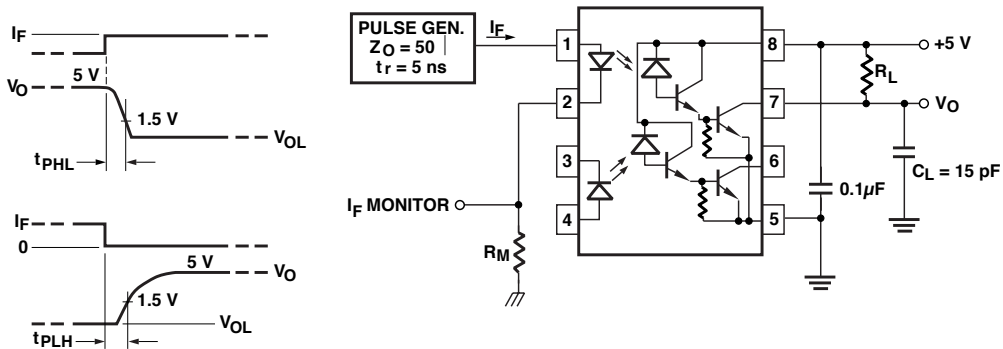

Figure 9. Switching test circuit.

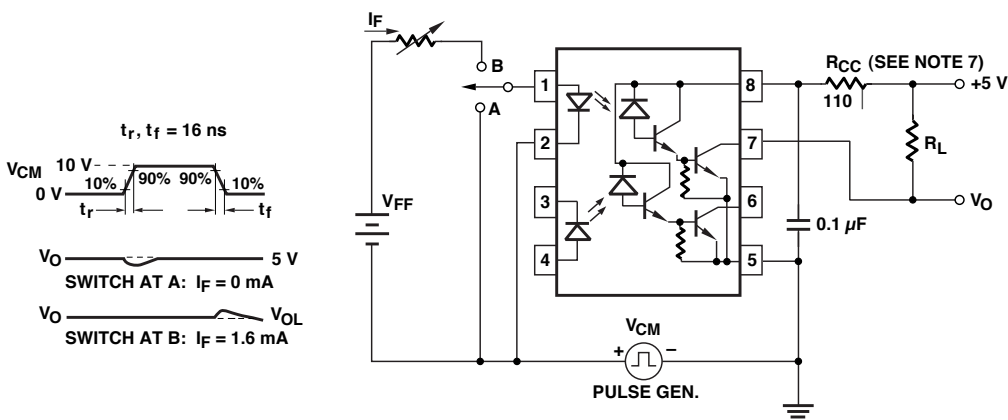

Figure 10. Test circuit for transient immunity and typical waveforms.

For product information and a complete list of distributors, please go to our website: www.avagotech.com

Avago, Avago Technologies, and the A logo are trademarks of Avago Technologies Limited in the United States and other countries. Data subject to change. Copyright © 2007 Avago Technologies Limited. All rights reserved. Obsoletes 5989-2105EN AV01-0546EN July 17, 2007





Компания «ЭлектроПласт» предлагает заключение долгосрочных отношений при поставках импортных электронных компонентов на взаимовыгодных условиях!

Наши преимущества:

- Оперативные поставки широкого спектра электронных компонентов отечественного и импортного производства напрямую от производителей и с крупнейших мировых складов;
- Поставка более 17-ти миллионов наименований электронных компонентов;
- Поставка сложных, дефицитных, либо снятых с производства позиций;
- Оперативные сроки поставки под заказ (от 5 рабочих дней);
- Экспресс доставка в любую точку России;
- Техническая поддержка проекта, помощь в подборе аналогов, поставка прототипов;
- Система менеджмента качества сертифицирована по Международному стандарту ISO 9001;
- Лицензия ФСБ на осуществление работ с использованием сведений, составляющих государственную тайну;
- Поставка специализированных компонентов (Xilinx, Altera, Analog Devices, Intersil, Interpoint, Microsemi, Aeroflex, Peregrine, Syfer, Eurofarad, Texas Instrument, Miteq, Cobham, E2V, MA-COM, Hittite, Mini-Circuits, General Dynamics и др.);

Помимо этого, одним из направлений компании «ЭлектроПласт» является направление «Источники питания». Мы предлагаем Вам помощь Конструкторского отдела:

- Подбор оптимального решения, техническое обоснование при выборе компонента;
- Подбор аналогов;
- Консультации по применению компонента;
- Поставка образцов и прототипов;
- Техническая поддержка проекта;
- Защита от снятия компонента с производства.



Как с нами связаться

Телефон: 8 (812) 309 58 32 (многоканальный)

Факс: 8 (812) 320-02-42

Электронная почта: org@eplast1.ru

Адрес: 198099, г. Санкт-Петербург, ул. Калинина, дом 2, корпус 4, литера А.