

IS31IO7328

MULTI-FUNCTION I/O DRIVER

January 2014

GENERAL DESCRIPTION

The IS31IO7328 2-wire serial-interfaced peripheral features 8 I/O ports. Ports are divided into four push pull I/Os and four open-drain I/Os and transition detection.

Any of the 8 I/O ports can be configured as an input or an output. All I/O ports configured as inputs are continuously monitored for state changes (transition detection). State changes are indicated by the INTB output. The interrupt is latched, allowing detection of transient changes. When the IS31IO7328 is subsequently read through the serial interface, any pending interrupt is cleared.

The open-drain outputs are rated to sink 20mA at 0.22V headroom, and are capable of driving LEDs. The RSTB input clears the serial interface, terminating any I²C communication to or from the IS31IO7328. The IS31IO7328 uses two address inputs to allow 2 I²C slave addresses. The slave address also determines the power-up logic state for the I/O ports.

FEATURES

- 400kHz I²C serial interface
- 2.4V to 5.5V operation
- 4 push-pull I/O ports
- 4 open-drain I/O ports, rated to 20mA sink current at 0.22V headroom
- Selectable I/O port power-up default logic states
- INTB output alerts change on inputs
- Low 0.3μA (Typ.) standby current
- -40°C to +125°C temperature range

APPLICATIONS

- Cell phones
- Notebooks
- SAN/NAS
- Satellite radio
- Servers
- Automotive

TYPICAL APPLICATION CIRCUIT

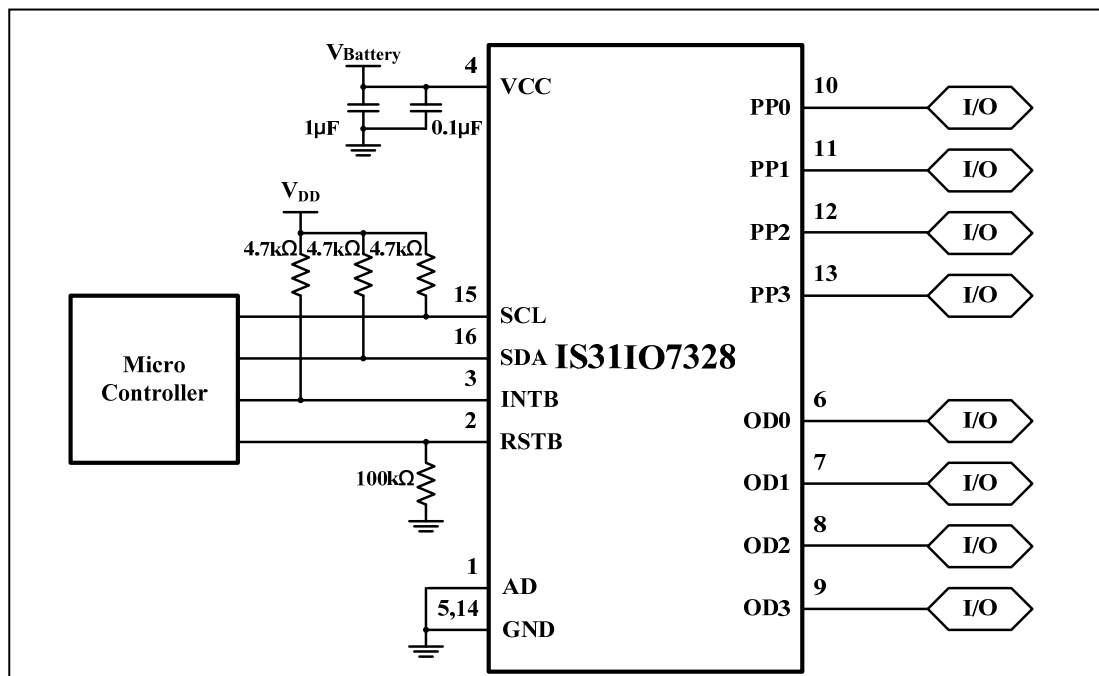
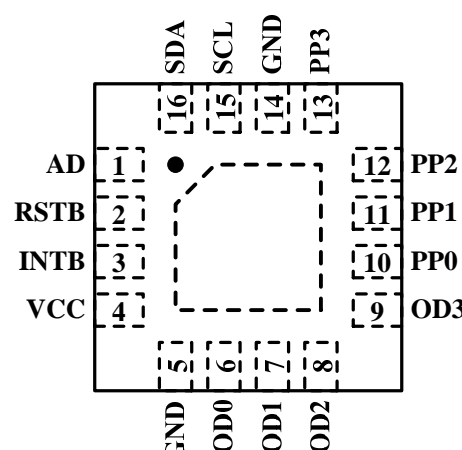

Figure 1 Typical Application Circuit

IS31IO7328

PIN CONFIGURATION

| Package | Pin Configuration (Top View) |
|---------|---|
| QFN-16 |  |

PIN DESCRIPTION

| No. | Pin | Description |
|-------|-------------|---|
| 1 | AD | Address Inputs. Select device slave address with AD. |
| 2 | RSTB | Reset Input, active Low. Drive RSTB pin low to clear the 2-wire interface. |
| 3 | INTB | Interrupt output, active Low. This is an open-drain output. |
| 4 | VCC | Positive supply voltage. Bypass V_{CC} to GND with a ceramic capacitor of at least $1\mu\text{F}$. |
| 5,14 | GND | Ground. |
| 6~9 | OD0~OD3 | Open-drain I/O ports. |
| 10~13 | PP0~PP3 | CMOS push-pull I/O ports. |
| 15 | SCL | I ² C-compatible serial-clock input. |
| 16 | SDA | I ² C-compatible serial-data I/O. |
| | Thermal Pad | Connect to GND. |



IS31IO7328

ORDERING INFORMATION

Industrial Range: -40°C to +125°C

| Order Part No. | Package | QTY/Reel |
|---------------------|-------------------|----------|
| IS31IO7328-QFLS4-TR | QFN-16, Lead-free | 2500 |

Copyright © 2014 Integrated Silicon Solution, Inc. All rights reserved. ISSI reserves the right to make changes to this specification and its products at any time without notice. ISSI assumes no liability arising out of the application or use of any information, products or services described herein. Customers are advised to obtain the latest version of this device specification before relying on any published information and before placing orders for products. Integrated Silicon Solution, Inc. does not recommend the use of any of its products in life support applications where the failure or malfunction of the product can reasonably be expected to cause failure of the life support system or to significantly affect its safety or effectiveness. Products are not authorized for use in such applications unless Integrated Silicon Solution, Inc. receives written assurance to its satisfaction, that:

- a.) the risk of injury or damage has been minimized;
- b.) the user assume all such risks; and
- c.) potential liability of Integrated Silicon Solution, Inc is adequately protected under the circumstances

IS31IO7328

ABSOLUTE MAXIMUM RATINGS

| | |
|--|-----------------------|
| Supply voltage, V_{CC} | -0.3V ~ +6.0V |
| Voltage at any input pin | -0.3V ~ $V_{CC}+0.3V$ |
| SCL, SDA, AD, RSTB, INTB, OD0~OD3 | -0.3V ~ +6.0V |
| PP0~PP3 | -0.3V ~ $V_{CC}+0.3V$ |
| PP source output current | $\pm 100mA$ |
| PP/OD sink current | 120mA |
| SDA sink current | 10mA |
| INTB sink current | 10mA |
| Maximum junction temperature, T_{JMAX} | 150°C |
| Storage temperature range, T_{STG} | -65°C ~ +150°C |
| Operating temperature range, T_A | -40°C ~ +125°C |
| ESD (HBM) | 4kV |
| ESD (CDM) | 1kV |

Note:

Stresses beyond those listed under "Absolute Maximum Ratings" may cause permanent damage to the device. These are stress ratings only and functional operation of the device at these or any other condition beyond those indicated in the operational sections of the specifications is not implied. Exposure to absolute maximum rating conditions for extended periods may affect device reliability.

ELECTRICAL CHARACTERISTICS

$T_A = -40^\circ C \sim +125^\circ C$, $V_{CC} = 2.4V \sim 5.5V$, unless otherwise noted.

Typical values are at $V_{CC} = 3.3V$, $T_A = 25^\circ C$. (Note 1)

| Symbol | Parameter | Condition | Min. | Typ. | Max. | Unit |
|------------------|---|--|------|------|------|---------|
| V_{CC} | Supply voltage | | 2.4 | | 5.5 | V |
| V_{POR} | Power-on-reset voltage | V_{CC} falling, $T_A = -40^\circ C$ | | | 2.35 | V |
| | | V_{CC} falling, $T_A = -20^\circ C$ | | | 2.3 | |
| I_{STB} | Standby current (Interface idle) | SCL and SDA and other digital inputs at V_{CC} | | 0.3 | 1.9 | μA |
| I^+ | Supply current (Interface running) | $f_{SCL} = 400kHz$, other digital inputs at V_{CC} | | 8 | 20 | μA |
| V_{IH} | Input high-voltage, SDA, SCL, AD, RSTB, OD0~OD3, PP0~PP3 | | 1.4 | | | V |
| V_{IL} | Input low-voltage, SDA, SCL, AD, RSTB, OD0~OD3, PP0~PP3 | | | | 0.4 | V |
| I_{IH}, I_{IL} | Input leakage current, SDA, SCL, AD, RSTB, OD0~OD3, PP0~PP3 | SDA, SCL, AD, RSTB, OD0~OD3, PP0~PP3 at V_{CC} or GND. | -0.2 | | +0.2 | μA |
| C_{IN} | Input capacitance, SDA, SCL, AD, RSTB, OD0~OD3, PP0~PP3 | (Note 3) | | 10 | | pF |
| V_{OL} | Output low voltage, PP0~PP3, OD0~OD3 | $V_{CC} = 2.5V$, $I_{SINK} = 10mA$ | | | 200 | mV |
| | | $V_{CC} = 3.3V$, $I_{SINK} = 15mA$ | | | 240 | |
| | | $V_{CC} = 5.0V$, $I_{SINK} = 20mA$ | | | 250 | |
| V_{OH} | Output high voltage PP0~PP3 | $V_{CC} = 2.5V$, $I_{SOURCE} = 5mA$ | 2.2 | | | mV |
| | | $V_{CC} = 3.3V$, $I_{SOURCE} = 5mA$ | 3.1 | | | |
| | | $V_{CC} = 5.0V$, $I_{SOURCE} = 10mA$ | 4.72 | | | |
| V_{OLSDA} | Output low-voltage SDA | $I_{SINK} = 6mA$ | | | 180 | mV |
| V_{OLINTB} | Output low-voltage INTB | $I_{SINK} = 5mA$ | | | 180 | mV |

IS31IO7328

TIMING CHARACTERISTICS

$V_{CC} = 2.4V \sim 5.5V$, unless otherwise noted. Typical values are at $V_{CC} = 3.3V$, $T_A = 25^\circ C$. (Note 3)

| Symbol | Parameter | Condition | Min. | Typ. | Max. | Unit |
|---------------|--|-----------|------|-------------|------|---------|
| f_{SCL} | Serial-clock frequency | | | | 400 | kHz |
| t_{BUF} | Bus free time between a STOP and a START Condition | | 1.3 | | | μs |
| $t_{HD, STA}$ | Hold time (repeated) START condition | | 0.6 | | | μs |
| $t_{SU, STA}$ | Repeated START condition setup time | | 0.6 | | | μs |
| $t_{SU, STO}$ | STOP condition setup time | | 0.6 | | | μs |
| $t_{HD, DAT}$ | Data hold time | (Note 2) | | | 0.9 | μs |
| $t_{SU, DAT}$ | Data setup time | | 100 | | | ns |
| t_{LOW} | SCL clock low period | | 1.3 | | | μs |
| t_{HIGH} | SCL clock high period | | 0.7 | | | μs |
| t_R | Rise time of both SDA and SCL signals, receiving | (Note 4) | | $20+0.1C_b$ | 300 | ns |
| t_F | Fall time of both SDA and SCL signals, receiving | (Note 4) | | $20+0.1C_b$ | 300 | ns |
| $t_{F, TX}$ | Fall time of SDA transmitting | (Note 4) | | $20+0.1C_b$ | 250 | ns |
| t_{SP} | Pulse width of spike suppressed | (Note 5) | | 50 | | ns |
| C_b | Capacitive load for each bus line | | | | 400 | pF |
| t_W | RSTB pulse width | | 500 | | | ns |
| t_{RSTB} | RSTB rising to START condition setup time | | 1 | | | μs |

PORT AND INTERRUPT INTB TIMING CHARACTERISTIC

$V_{CC} = 2.4V \sim 5.5V$, unless otherwise noted. Typical values are at $V_{CC} = 3.3V$, $T_A = 25^\circ C$. (Note 3)

| Parameter | Symbol | Condition | Min. | Typ. | Max. | Unit |
|--|-----------|------------------|------|------|------|---------|
| Port Output Data Valid | t_{PV} | $C_L \leq 100pF$ | | | 4 | μs |
| Port Input Setup Time | t_{PSU} | $C_L \leq 100pF$ | 0 | | | μs |
| Port Input Hold Time | t_{PH} | $C_L \leq 100pF$ | 4 | | | μs |
| INTB Input Data Valid Time | t_{IV} | $C_L \leq 100pF$ | | | 4 | μs |
| INTB Reset Delay Time from Acknowledge | t_{IR} | $C_L \leq 100pF$ | | | 4 | μs |

Note 1: All parameters are tested at $T_A = 25^\circ C$. Specifications over temperature are guaranteed by design.

Note 2: A master device must provide a hold time of at least 300ns for the SDA signal (referred to V_{IL} of the SCL signal) in order to bridge the undefined region of SCL's falling edge.

Note 3: Guaranteed by design.

Note 4: C_b = total capacitance of one bus line in pF. $I_{SINK} \leq 6mA$. t_R and t_F measured between $0.3 \times V_{CC}$ and $0.7 \times V_{CC}$.

Note 5: Input filters on the SDA and SCL inputs suppress noise spikes less than 50ns.

IS3107328

Table 1 Power Up Default State For I/O Ports

| Pin Connection | Port Power Up Default | | | | | | | |
|----------------------|-----------------------|-----|-----|-----|------|------|------|------|
| | PP3 | PP2 | PP1 | PP0 | OD3 | OD2 | OD1 | OD0 |
| AD = GND | 0 | 0 | 0 | 0 | 0 | 0 | 0 | 0 |
| AD = V _{CC} | 1 | 1 | 1 | 1 | Hi-Z | Hi-Z | Hi-Z | Hi-Z |

Table 2 Command Byte Register

| Command Byte Address | Function | Power-up Default | Protocol |
|----------------------|--------------------------|------------------|----------|
| 00h (Note 6) | Input port A (OD0~OD3) | XXXX | R |
| 01h (Note 6) | Input port B (PP0~PP3) | XXXX | R |
| 02h (Note 6) | Output port A | Refer to Table 1 | R/W |
| 03h (Note 6) | Output port B | Refer to Table 1 | R/W |
| 04h (Note 6,7) | Port A configuration | 0000 | R/W |
| 05h (Note 6,7) | Port B configuration | 0000 | R/W |
| 06h (Note 6) | Port A interrupt control | 0000 | R/W |
| 07h (Note 6) | Port B interrupt control | 0000 | R/W |

Note 6: When reading or writing data from/to the port A/B, the 4 MSBs of the data are effective

Note 7: When configuring the command byte registers with address 04 or 05, the LSBs of data have to be set to 0.

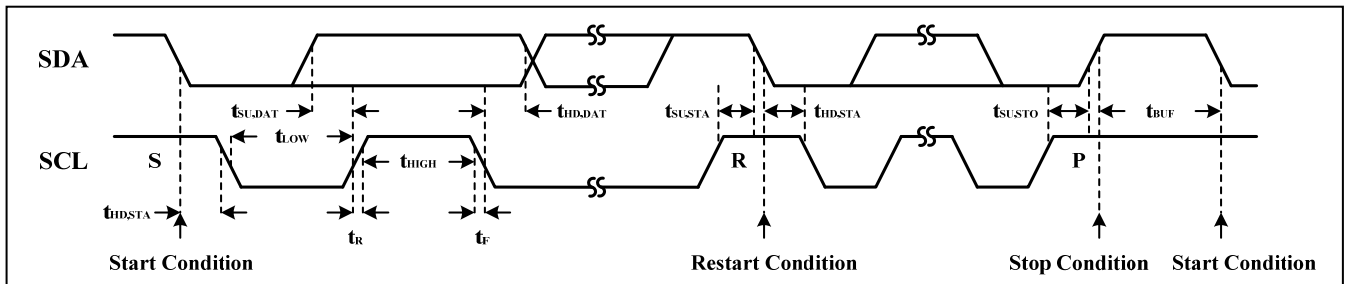

Figure 2 2-Wire Serial Interface Timing Details

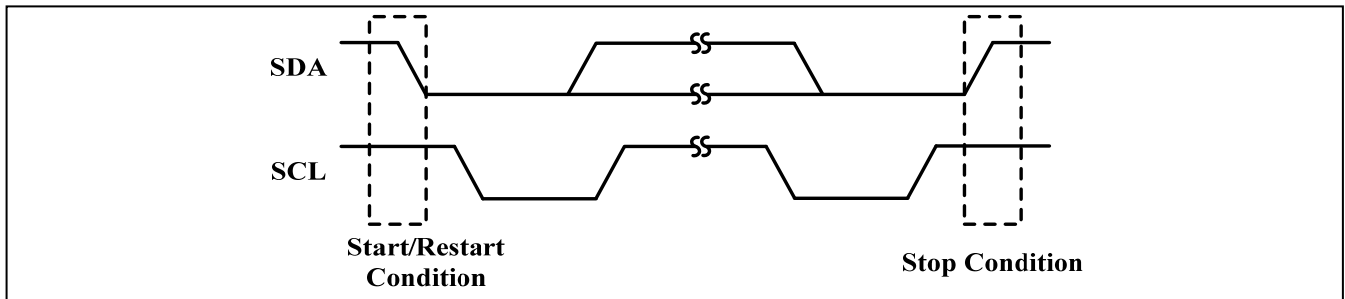

Figure 3 START and STOP Conditions

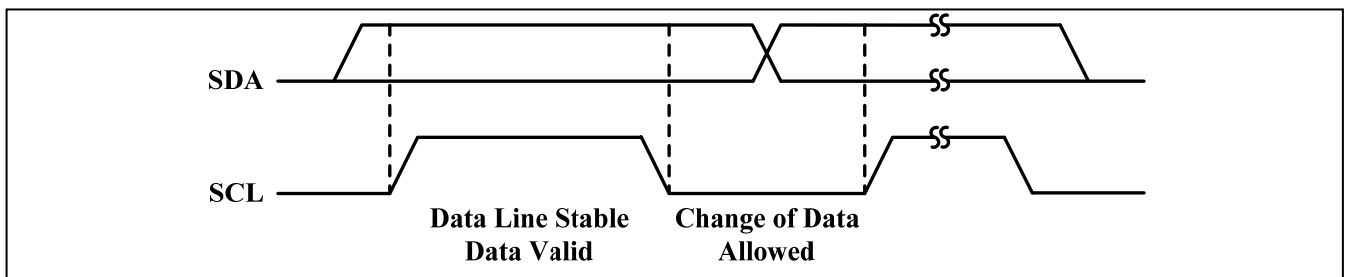
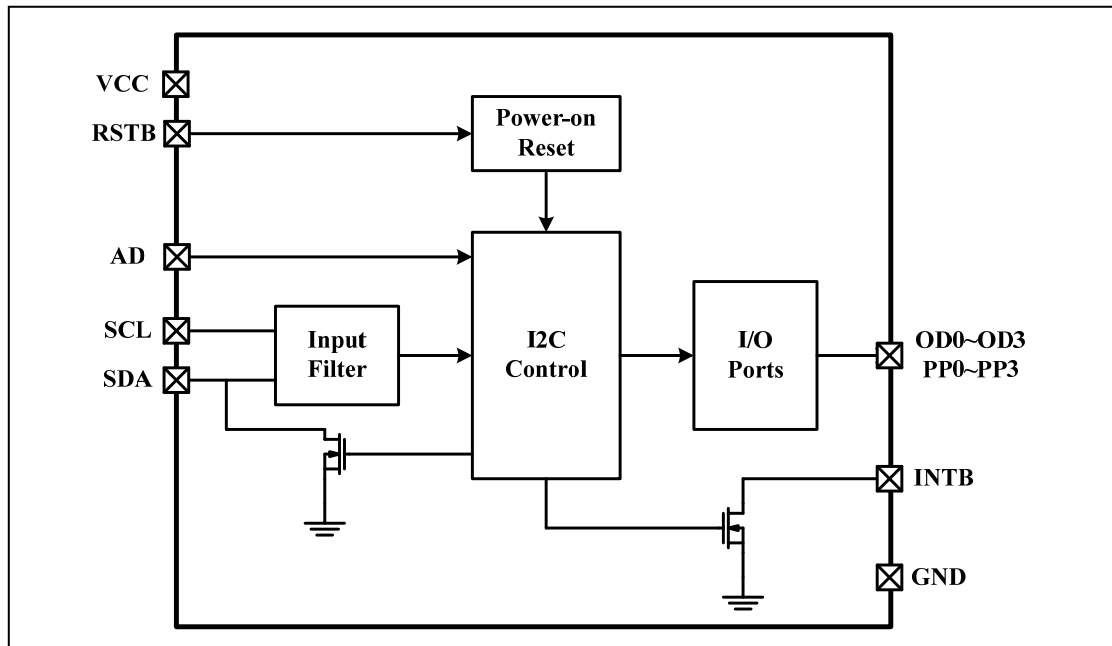

Figure 4 Bit Transfer

IS31IO7328

FUNCTIONAL BLOCK DIAGRAM



IS31IO7328

APPLICATION INFORMATION

FUNCTIONAL OVERVIEW

The IS31IO7328 is a Multi-function I/O driver operating from a 2.4V to 5.5V supply with four push-pull and four open-drain I/O ports. Each open-drain and push-pull port is rated to sink 20mA at 0.22V headroom, and the entire device is rated to sink 160mA at 0.22V headroom into all ports combined. The outputs drive loads connected to supplies up to +5.5V.

The IS31IO7328 is set to two I²C slave addresses using the address select inputs AD, and is accessed over an I²C serial interface up to 400kHz. The RSTB input clears the serial interface in case of a bus lockup, terminating any serial transaction to or from the IS31IO7328.

The IS31IO7328 consists of input, output port registers, configuration registers and interrupt control register. All I/O ports offer latching transition detection when configured as inputs. All input ports are continuously monitored for changes.

A latching interrupt output, INTB, is programmed to flag logic changes on ports used as inputs. Data changes on any input port forces INTB to a logic-low. Changing the I/O port level through the serial interface does not cause an interrupt. The interrupt output INTB is cleared successfully by reading the corresponding input/output ports.

Ports default to logic-high or logic-low on power-up in groups of two (see Table 1).

INITIAL POWER-UP

On power-up, the transition detection logic is reset, and INTB is reset. The power-up default states of the 8 I/O ports are set according to the I²C slave address selection inputs, AD (see Table 1). For I/O ports used as inputs, ensure that the default states are logic-high so that the I/O ports power up in the high impedance state.

POWER-ON RESET

The IS31IO7328 contains an integral power-on-reset (POR) circuit that ensures all registers are reset to a known state on power-up. When V_{CC} rises above V_{POR} (2.3V max), the POR circuit releases the registers and 2-wire interface for normal operation. When V_{CC} drops to less than V_{POR} , the IS31IO7328 resets all register contents to the POR defaults.

RSTB INPUT

The active-low RSTB input voids any I²C transaction involving the IS31IO7328, forcing the IS31IO7328 into the I²C STOP condition. A reset does not affect the interrupt output.

STANDBY MODE

When the serial interface is idle, the IS31IO7328 automatically enters standby mode, drawing minimal supply current.

I/O PORT INPUT TRANSITION DETECTION

All I/O ports configured as inputs are monitored for changes since the expander was last accessed through the serial interface. The open-drain interrupt output, INTB, activates when one of the port pins changes states and only when the pin is configured as an input. The interrupt deactivates when the input/output register is read. A pin configured as an output does not cause an interrupt. Each 8-bit port register is read independently; therefore, an interrupt caused by port A (OD0~OD3) is not cleared by a read of port B (PP0~PP3)'s register.

Changing an I/O from an output to an input may cause a false interrupt to occur if the state of that I/O does not match the content of output port register. The IS31IO7328 has interrupt control register to avoid false interrupt by setting the interrupt control register bit high firstly, when the I/O state is stable, clear the interrupt control register to enable the input transition detection function.

ACCESSING THE IS31IO7328

Serial Addressing

The IS31IO7328 operates as a slave that sends and receives data through a 2-wire interface. The interface uses a serial data line (SDA) and a serial clock line (SCL) to achieve bidirectional communication between master(s) and slave(s). A master, typically a microcontroller, initiates all data transfers to and from the IS31IO7328, and generates the SCL clock that synchronizes the data transfer (see Figure 2).

SDA operates as both an input and an open-drain output. A pull up resistor, typically 4.7k Ω , is required on SDA. SCL operates only as an input. A pull up resistor, typically 4.7k Ω , is required on SCL if there are multiple masters on the 2-wire interface, or if the master in a single-master system has an open-drain SCL output. Each transmission consists of a START condition sent by a master, followed by the IS31IO7328's 7-bit slave addresses plus R/W bits, 1 or more data bytes, and finally a STOP condition (see Figure 3).

IS31IO7328

START and STOP Conditions

Both SCL and SDA remain high when the interface is not busy. A master signals the beginning of a transmission with a START (S) condition by transitioning SDA from high to low while SCL is high.

When the master has finished communicating with the slave, the master issues a STOP (P) condition by transitioning SDA from low to high while SCL is high. The bus is then free for another transmission (see Figure 3).

Bit Transfer

One data bit is transferred during each clock pulse. The data on SDA must remain stable while SCL is high (Figure 4).

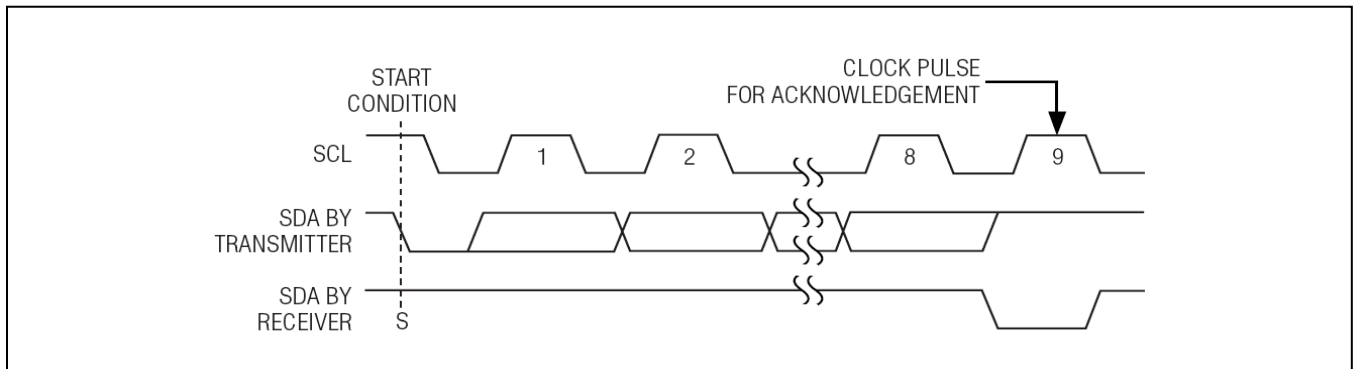

Figure 5 Acknowledge

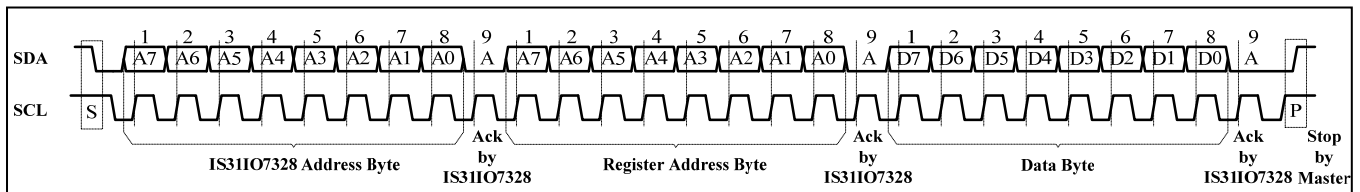

Figure 6 Writing to the IS31IO7328

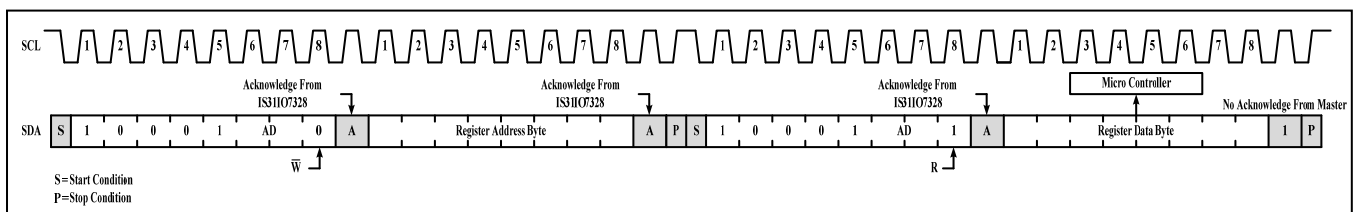

Figure 7 Reading I/O Ports of IS31IO7328

Note: Data from/to IS31IO7328, only the 4 MSBs of the data are effective.

IS31IO7328

Slave Address

The IS31IO7328 uses a serial bus, which conforms to the I2C protocol, to control the chip's functions with two wires: SCL and SDA. The IS31IO7328 has a 7-bit slave address (A7:A1), followed by the $\overline{R/W}$ bit, A0. Set A0 to "0" for a write command and set A0 to "1" for a read command. The bit A2 is selected by the connection of AD pin.

The complete slave address is:

Table 3 Slave Address:

| Bit | A7:A3 | A2 | A1 | A0 |
|---------|-------|----|----|-----|
| Default | 10110 | AD | 0 | 0/1 |

AD connects to VCC, AD =1;
AD connects to GND, AD =0;

Data Bus Transaction

The command byte is the first byte to follow the 8-bit device slave address during a write transmission (see Table 2). The command byte is used to determine which of the following registers are written or read.

Acknowledge

The acknowledge bit is a clocked 9th bit the recipient uses to acknowledge receipt of each byte of data (see Figure 5). Each byte transferred effectively requires 9bits. The master generates the 9th clock pulse, and the recipient pulls down SDA during the acknowledge clock pulse, such that the SDA line is stable low during the high period of the clock pulse. When the master is transmitting to the IS31IO7328, the device generates the acknowledge bit because the IS31IO7328 is the recipient. When the IS31IO7328 is transmitting to the master, the master generates the acknowledge bit because the master is the recipient.

Configuration Registers

The configuration registers configure the directions of the I/O pins. Set the bit in the respective configuration register to enable the corresponding port as an input. Clear the bit in the configuration register to enable the corresponding port as an output. The 4 LSBs of the command data should be set to 0.

Interrupt Control Registers

The interrupt control registers control the interrupt function of I/O ports when the I/O port used as input. Set the bit in the respective interrupt control register to disable the corresponding port's interrupt function. Clear the bit in the interrupt control register to enable the corresponding port's interrupt function.

Writing to Port Registers

Transmit data to the IS31IO7328 by sending the device slave address and setting the LSB to a logic zero. The command byte is sent after the address and determines which registers receive the data following

the command byte.

A write to either output port groups of the IS31IO7328 starts with the master transmitting the group's slave address with the $\overline{R/W}$ bit set low. The master can now transmit one or more bytes of data. The IS31IO7328 acknowledges these subsequent bytes of data and updates the corresponding group's ports with each new byte until the master issues a STOP condition (Figure 6).

Reading Port Registers

To read the device data, the bus master must first send the IS31IO7328 address with the $\overline{R/W}$ bit set to zero, followed by the command byte, which determines which register is accessed. After a restart, the bus master must then send the IS31IO7328 address with the $\overline{R/W}$ bit set to 1. Data from the register defined by the command byte is then sent from the IS31IO7328 to the master.

The IS31IO7328 acknowledges the slave address, and samples the ports during the acknowledge bit. INTB asserts during the slave address acknowledge. When the master reads one byte from the I/O ports of the IS31IO7328 and subsequently issues a STOP condition (Figure 7), the IS31IO7328 transmits the current port data, clears the change flags, and resets the transition detection. INTB asserts during the slave acknowledge. The new snapshot data is the current port data transmitted to the master, and therefore, port changes occurring during the transmission are detected.

Port Output Signal-Level Translation

The open-drain output architecture allows for level translation to higher or lower voltages than the IS31IO7328's supply. Each of the push-pull output ports has protection diodes to V+ and GND. When a port output is driven to a voltage higher than V+ or lower than GND, the appropriate protection diode clamps the output to a diode drop above V+ or below GND. When the IS31IO7328 is powered down (V+ = 0V), every output port's protection diodes to V+ and GND continue to appear as a diode clamp from each output to GND (Figure 8). Each of the I/O ports OD0~OD3 has a protection diode to GND (Figure 9). When a port is driven to a voltage lower than GND, the protection diode clamps the port to a diode drop below GND. To obtain a high voltage, Open-Drain I/O Ports should connect a resistance to V_{DD} (Figure 9).

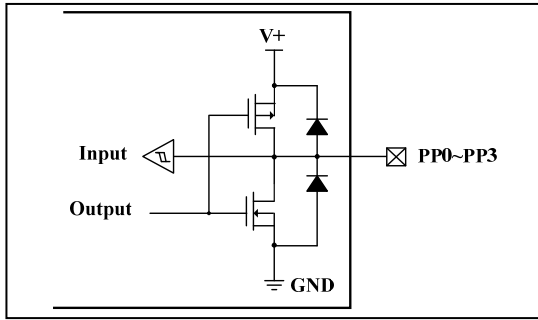

Figure 8 IS31IO7328 Push-Pull I/O Ports Structure

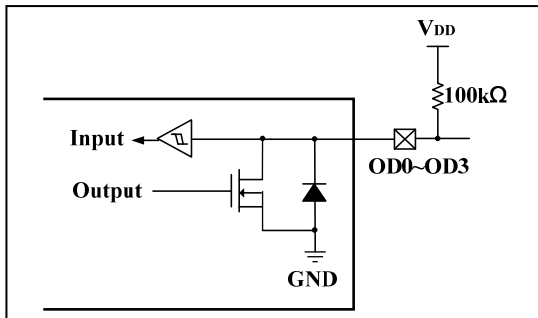

Figure 9 IS31IO7328 Open-Drain I/O Ports Structure

DRIVING LEDs

In the case that an OD output is used to drive an LED, a 100kΩ pull-up resistor should be used to prevent the output from floating while the LED is off. An OD port which is left floating may experience a slight increase in input leakage current due to the input structure of the I/O port.

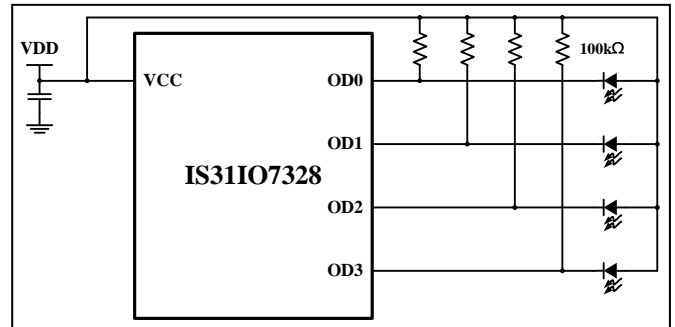

Figure 10 Driving LEDs with OD Ports

IS31IO7328

CLASSIFICATION REFLOW PROFILES

| Profile Feature | Pb-Free Assembly |
|--|----------------------------------|
| Preheat & Soak Temperature min (T _{smin}) Temperature max (T _{smax}) Time (T _{smin} to T _{smax}) (t _s) | 150°C 200°C 60-120 seconds |
| Average ramp-up rate (T _{smax} to T _p) | 3°C/second max. |
| Liquidous temperature (T _L) Time at liquidous (t _L) | 217°C 60-150 seconds |
| Peak package body temperature (T _p)* | Max 260°C |
| Time (t _p)** within 5°C of the specified classification temperature (T _c) | Max 30 seconds |
| Average ramp-down rate (T _p to T _{smax}) | 6°C/second max. |
| Time 25°C to peak temperature | 8 minutes max. |

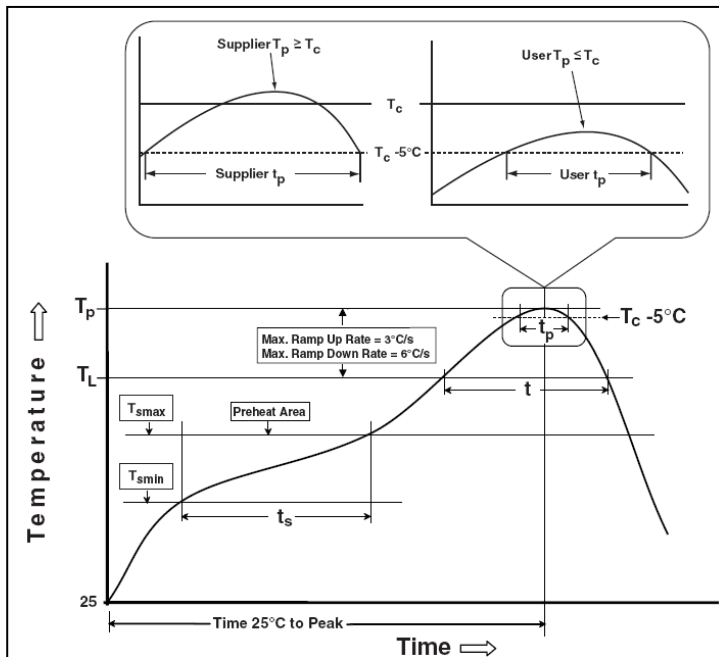
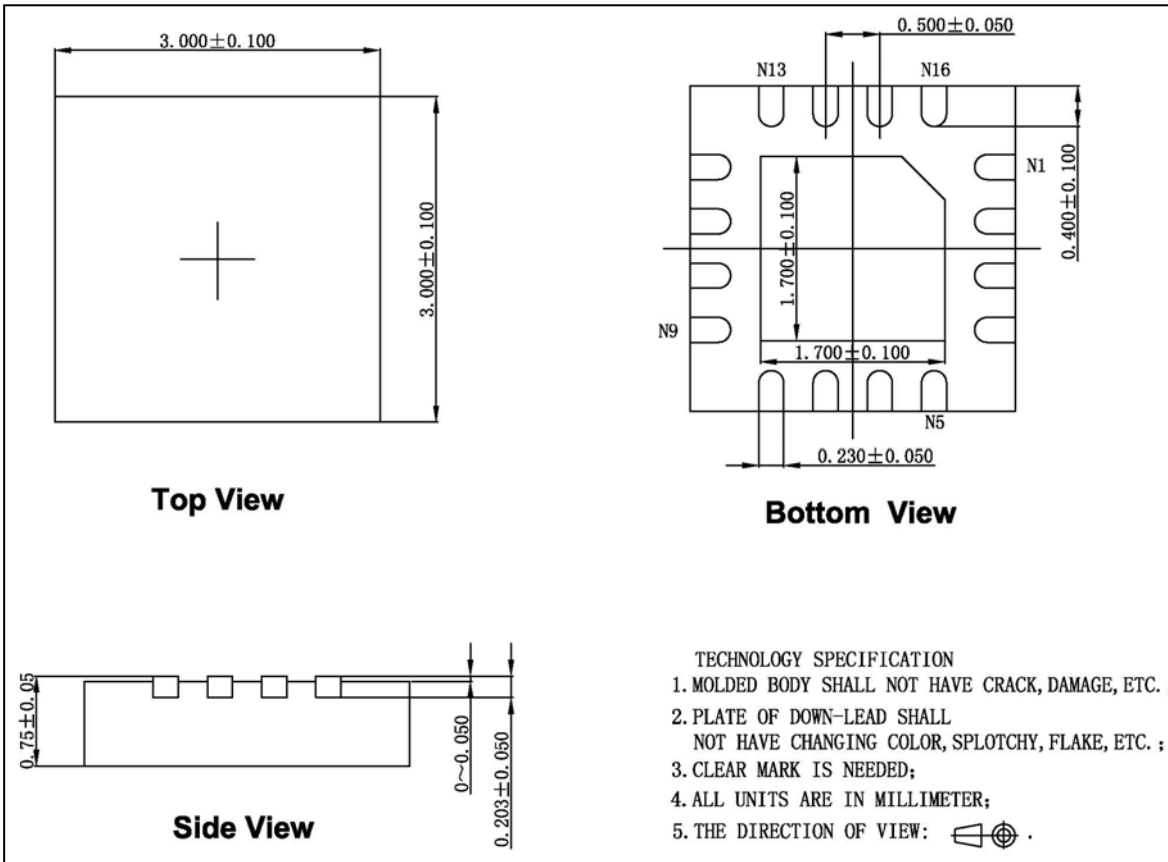

Figure 11 Classification Profile

IS311O7328

PACKAGE INFORMATION

QFN-16



Note: All dimensions in millimeters unless otherwise stated.



Компания «ЭлектроПласт» предлагает заключение долгосрочных отношений при поставках импортных электронных компонентов на взаимовыгодных условиях!

Наши преимущества:

- Оперативные поставки широкого спектра электронных компонентов отечественного и импортного производства напрямую от производителей и с крупнейших мировых складов;
- Поставка более 17-ти миллионов наименований электронных компонентов;
- Поставка сложных, дефицитных, либо снятых с производства позиций;
- Оперативные сроки поставки под заказ (от 5 рабочих дней);
- Экспресс доставка в любую точку России;
- Техническая поддержка проекта, помощь в подборе аналогов, поставка прототипов;
- Система менеджмента качества сертифицирована по Международному стандарту ISO 9001;
- Лицензия ФСБ на осуществление работ с использованием сведений, составляющих государственную тайну;
- Поставка специализированных компонентов (Xilinx, Altera, Analog Devices, Intersil, Interpoint, Microsemi, Aeroflex, Peregrine, Syfer, Eurofarad, Texas Instrument, Miteq, Cobham, E2V, MA-COM, Hittite, Mini-Circuits, General Dynamics и др.);

Помимо этого, одним из направлений компании «ЭлектроПласт» является направление «Источники питания». Мы предлагаем Вам помощь Конструкторского отдела:

- Подбор оптимального решения, техническое обоснование при выборе компонента;
- Подбор аналогов;
- Консультации по применению компонента;
- Поставка образцов и прототипов;
- Техническая поддержка проекта;
- Защита от снятия компонента с производства.



Как с нами связаться

Телефон: 8 (812) 309 58 32 (многоканальный)

Факс: 8 (812) 320-02-42

Электронная почта: org@eplast1.ru

Адрес: 198099, г. Санкт-Петербург, ул. Калинина, дом 2, корпус 4, литера А.