

### Features

- 34 dBm P1dB
- Pout 26 dBm @ EVM = 2.5% (PAR=9.17 dB)
- 46 dBm OIP3
- 18.5 dB Gain
- 8V Voltage Supply
- Input Internally Matched
- 7x7mm Surface Mount Package
- Ideal for WiMAX Applications @ 5.8 GHz and
- Applications between 4 GHz and 5 GHz
- RoHS\* Compliant and 260°C Reflow Compatible

### Description

The XP1044 is a highly linear 2-stage power amplifier capable of 18.5 dB of gain, 34 dBm of power at 1 dB compression and is housed in an RoHS compliant 7x7mm package. The XP1044 provides less than 2.5% EVM at 26 dBm output power with 802.16 OFDM signal and peak to average ratio 9.17 dB. The input and output of the device are internally pre-matched facilitating a simplified input and output match. This product operates off an 8V voltage supply and requires negative voltage which is used for current control. The XP1044-QL is specifically designed for WiMAX applications between 4.9 GHz and 5.9 GHz, and the performance can be shifted by adding external matching components to cover applications between 4.0 GHz and 5.0 GHz.

### Ordering Information

Part Number	Package
XP1044-QL-0N00	bulk quantity
XP1044-QL-EV1	evaluation module for 4.9 GHz ~ 5.9 GHz
XP1044-QL-EV2	evaluation module for 4.0 GHz ~ 5.0 GHz

### Functional Block Diagram

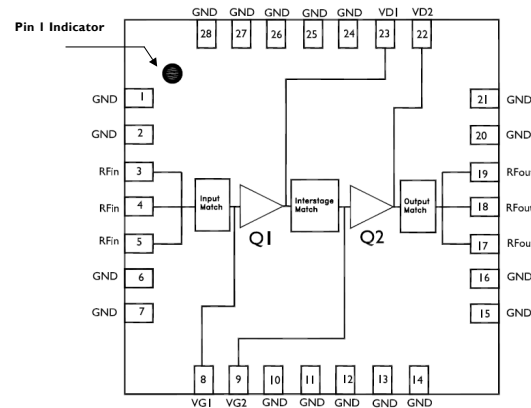

### Pin Configuration

Pin No.	Function	Pin No.	Function
3,4,5	RF IN	23	VD1
8	VG1	22	VD2
9	VG2	1,2,6,7,10,11,12,13,14,15,16,20,21,24,25,26,27,28	GND
17,18,19	RF OUT		

### Absolute Maximum Ratings

Parameter	Absolute Max.
Drain Supply Voltage (Vd)	+9.0 V
Gate Supply Voltage (Vg)	0 V ~ -5 V
RF Input Power (RFin)	+23 dBm
Stage 1 Current (Idd1)	375 mA
Stage 2 Current (Idd2)	750 mA
Power Dissipation (PDC)	9.0 W
Storage Temperature	-55 °C to +150 °C
Junctions Temperature	175 °C
Operating Temperature (Ta)	-40 °C to See Note 2
ESD (HBM)	Class 1A
Moisture Sensitivity level	MSL3
Thermal Resistance (Rth) <sup>1</sup>	15.6 °C

- (1) \*Thermal resistance of stage 2 only  
 (2) Calculate maximum operating backside temperature using:  $T_{max} = 167\text{ °C} - [V_d \cdot I_{dd2} \cdot R_{th}]$ . Thermal resistance of the 1st stage is 2x Rth of the output stage, and therefore Idd1 must not exceed 1/2 Idd2 for a specific maximum temperature

**Electrical Specifications: 4.9-5.9 GHz (5.8 GHz Typ.) (Ambient Temperature T = 25°C)<sup>1</sup>**

Parameter	Units	Min.	Typ.	Max.
Power Gain	dB	16.5	18.5	
Linear Power (@ EVM=2.5%, OFDM, 802.16 PAR=9.17 dB)	dBm		26.0	
Input Return Loss (S11)	dB		-10.0	
Output IP3 @ 22 dBm/Tone	dBm	44	46.0	
Noise Figure	dB		5	
Output P1dB	dBm	32.5	34.0	
Stage 1 Supply Current (Idd1)	mA		300	
Stage 2 Supply Current (Idd2)	mA		600	
Stage 1 Gate Voltage (Vg1)	V	-1.2	-0.85	-0.5
Stage 2 Gate Voltage (Vg2)	V	-1.2	-0.85	-0.5
Supply Voltage (Vd1 & Vd2)	V		8.0	

(1) Unless otherwise specified, the following specifications are guaranteed at room temperature in a M/A-COM Tech test fixture.

# XP1044-QL

**3W Power Amplifier Module**  
4.0-5.9 GHz

Rev. V2  
MimiX Broadband

## Evaluation Board Layout (4.9 GHz ~ 5.9 GHz)

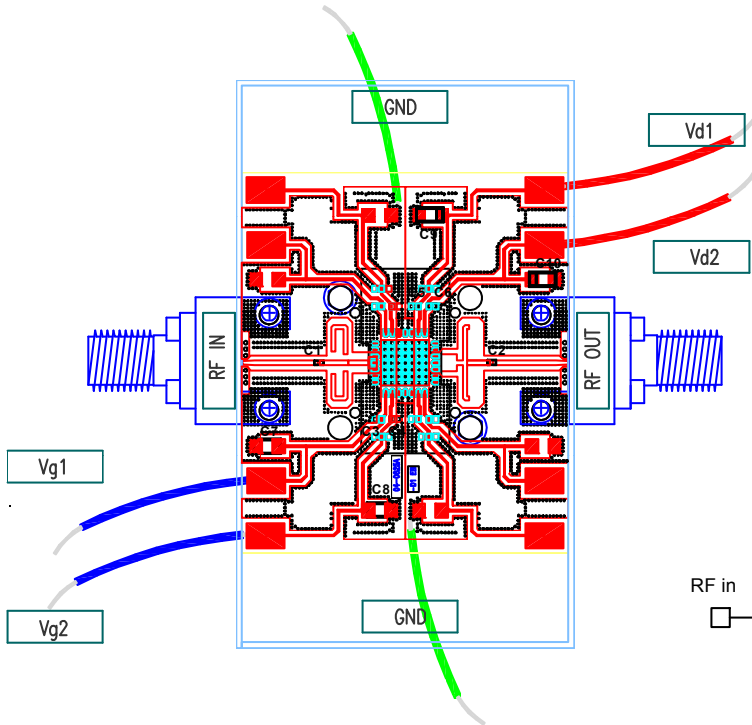

Ref Designator	Description	QTY
C1, C2	10.0 pF 0402 Capacitor	1
C3, C4, C5, C6	1000 pF 0402 Capacitor	4
C7, C8, C9, C10	1 uF A-Case Capacitor	4

Material: Rogers 4003  
Thickness: 8mil

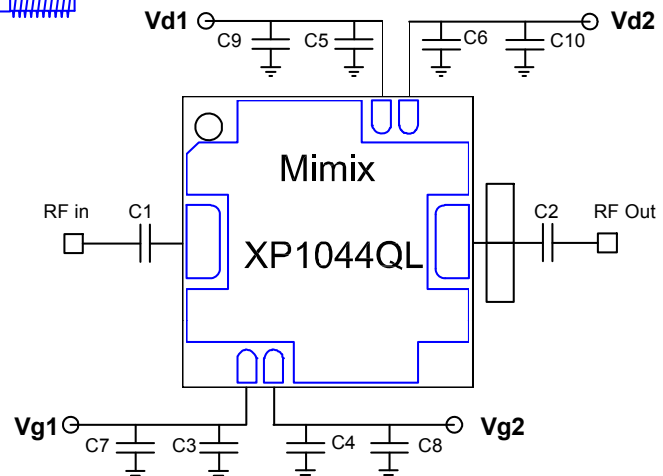

Dimensions are in inches.

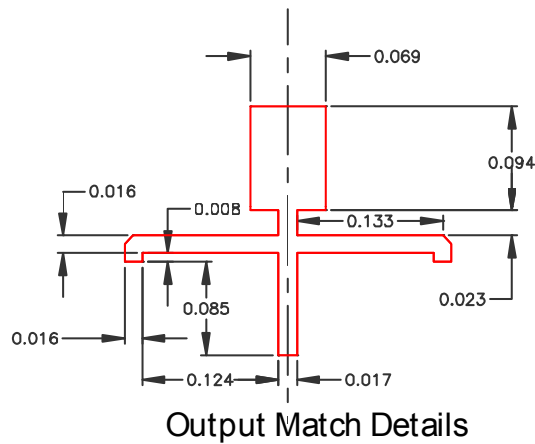
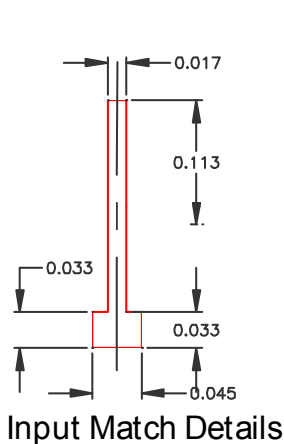

For improved performance at 6 GHz the thick transmission line ( $W=0.069''$ ) on the output can be extended to touch the two open stubs.

# XP1044-QL



**3W Power Amplifier Module**  
4.0-5.9 GHz

Rev. V2  
MimiX Broadband

## Typical Performance Curves (EV1, Idq1 = 300 mA, Idq2 = 600 mA)

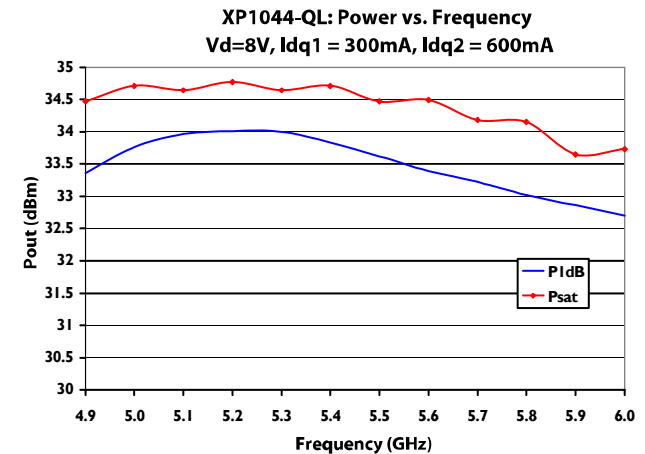
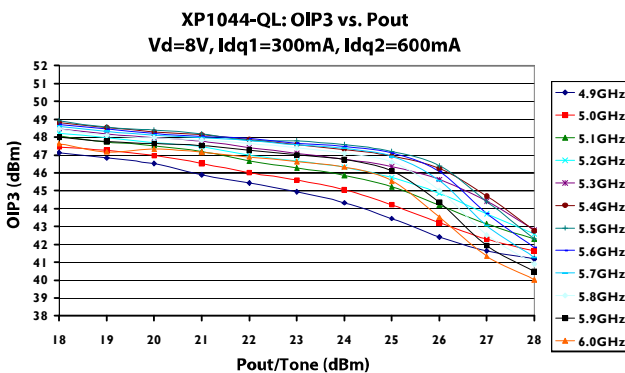
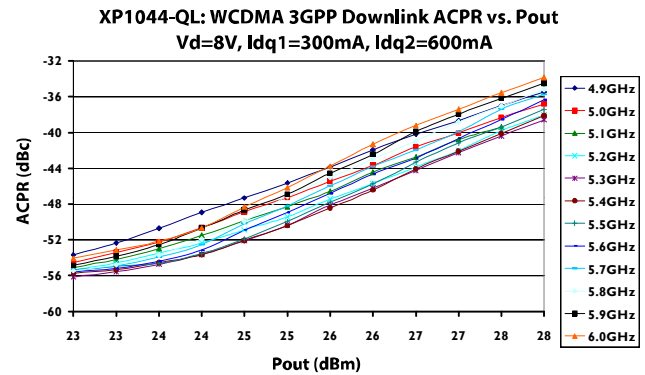
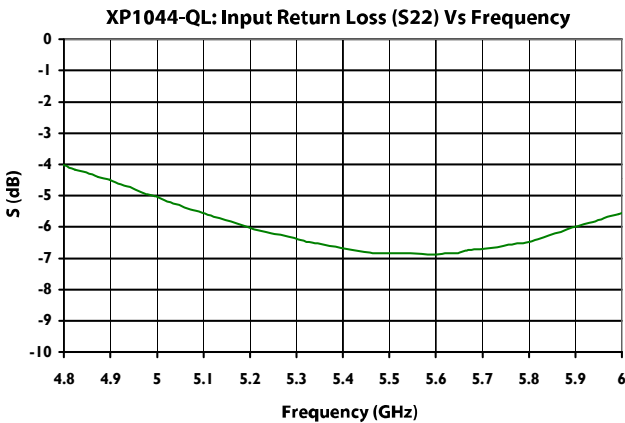
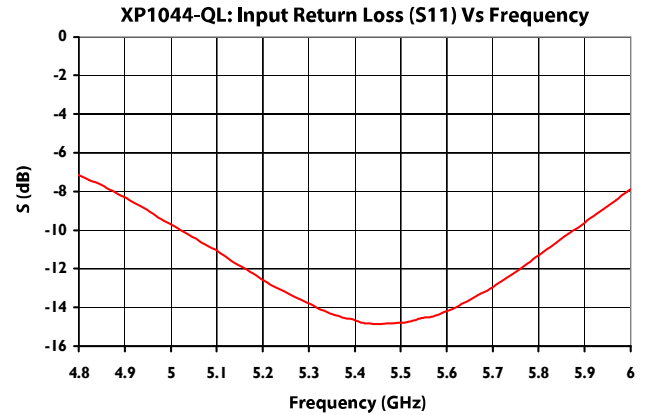
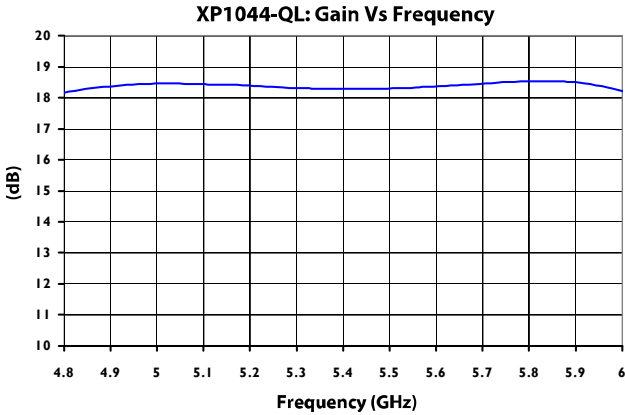

**ADVANCED:** Data Sheets contain information regarding a product M/A-COM Technology Solutions is considering for development. Performance is based on target specifications, simulated results, and/or prototype measurements. Commitment to develop is not guaranteed.  
**PRELIMINARY:** Data Sheets contain information regarding a product M/A-COM Technology Solutions has under development. Performance is based on engineering tests. Specifications are typical. Mechanical outline has been fixed. Engineering samples and/or test data may be available. Commitment to produce in volume is not guaranteed.

• **North America** Tel: 800.366.2266 • **Europe** Tel: +353.21.244.6400  
 • **India** Tel: +91.80.43537383 • **China** Tel: +86.21.2407.1588  
 Visit [www.macomtech.com](http://www.macomtech.com) for additional data sheets and product information.

M/A-COM Technology Solutions Inc. and its affiliates reserve the right to make changes to the product(s) or information contained herein without notice.

# XP1044-QL



**3W Power Amplifier Module**  
**4.0-5.9 GHz**

Rev. V2  
 MimiX Broadband

## Typical Performance Curves (EV1, Idq1 = 300 mA, Idq2 = 600 mA, Over Temp)

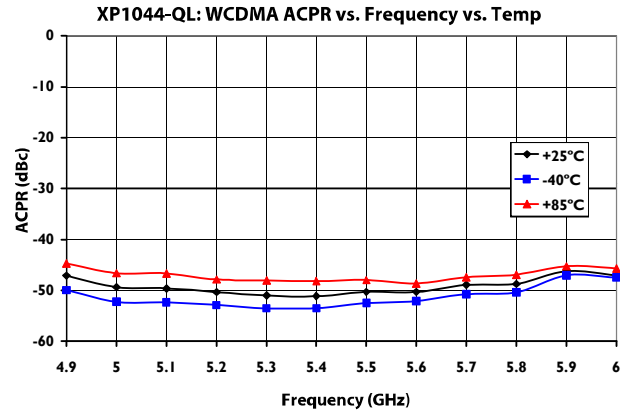
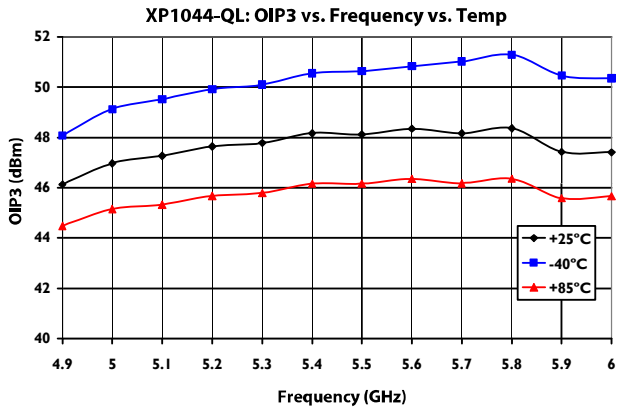
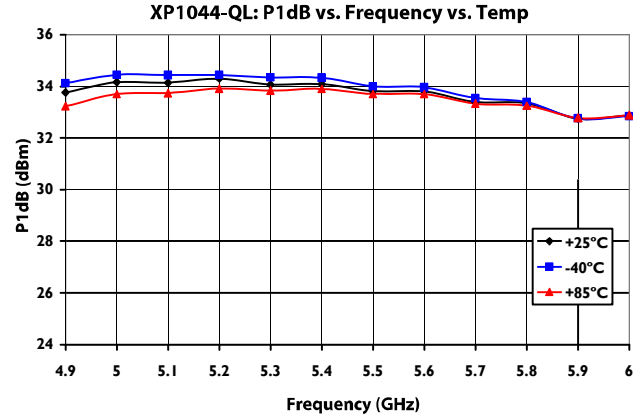
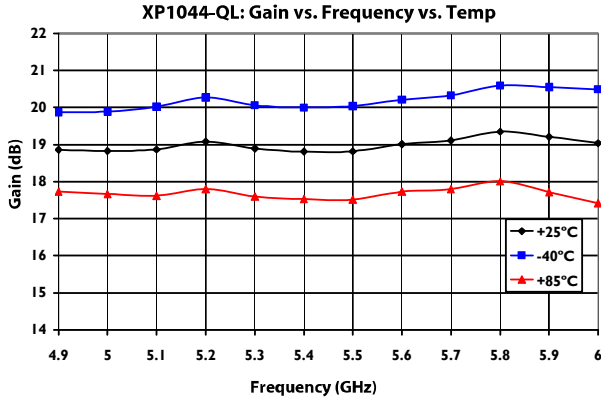

**ADVANCED:** Data Sheets contain information regarding a product M/A-COM Technology Solutions is considering for development. Performance is based on target specifications, simulated results, and/or prototype measurements. Commitment to develop is not guaranteed.  
**PRELIMINARY:** Data Sheets contain information regarding a product M/A-COM Technology Solutions has under development. Performance is based on engineering tests. Specifications are typical. Mechanical outline has been fixed. Engineering samples and/or test data may be available. Commitment to produce in volume is not guaranteed.

• **North America** Tel: 800.366.2266 • **Europe** Tel: +353.21.244.6400  
 • **India** Tel: +91.80.43537383 • **China** Tel: +86.21.2407.1588  
 Visit [www.macomtech.com](http://www.macomtech.com) for additional data sheets and product information.

M/A-COM Technology Solutions Inc. and its affiliates reserve the right to make changes to the product(s) or information contained herein without notice.

# XP1044-QL



**3W Power Amplifier Module**  
4.0-5.9 GHz

Rev. V2  
MimiX Broadband

## Typical Performance Curves (EV1, Idq1 = 330 mA, Idq2 = 660 mA)

**XP1044-QL: P1dB vs. Frequency**  
Vd=8V, Idq1 = 330mA, Idq2 = 660mA

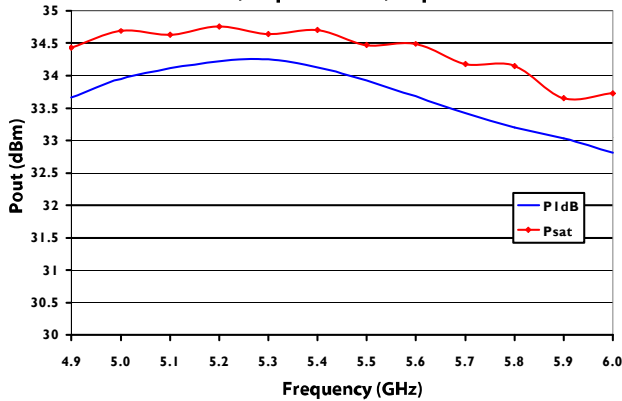

**XP1044-QL: WCDMA 3GPP Downlink ACPR vs. Pout**  
Vd=8V, Idq1=330mA, Idq2=660mA

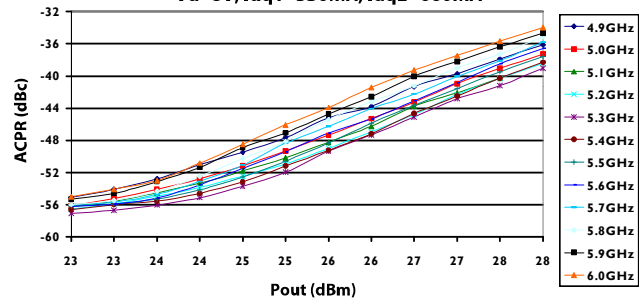

**XP1044-QL: OIP3 vs. Pout**  
Vd=8V, Idq1=330mA, Idq2=660mA

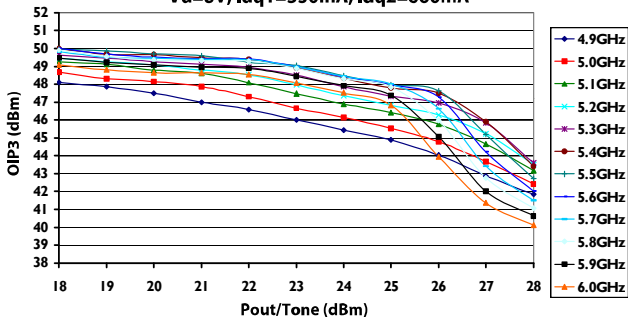

**ADVANCED:** Data Sheets contain information regarding a product M/A-COM Technology Solutions is considering for development. Performance is based on target specifications, simulated results, and/or prototype measurements. Commitment to develop is not guaranteed.  
**PRELIMINARY:** Data Sheets contain information regarding a product M/A-COM Technology Solutions has under development. Performance is based on engineering tests. Specifications are typical. Mechanical outline has been fixed. Engineering samples and/or test data may be available. Commitment to produce in volume is not guaranteed.

• **North America** Tel: 800.366.2266 • **Europe** Tel: +353.21.244.6400  
 • **India** Tel: +91.80.43537383 • **China** Tel: +86.21.2407.1588  
 Visit [www.macomtech.com](http://www.macomtech.com) for additional data sheets and product information.

M/A-COM Technology Solutions Inc. and its affiliates reserve the right to make changes to the product(s) or information contained herein without notice.

# XP1044-QL

**3W Power Amplifier Module**  
**4.0-5.9 GHz**

Rev. V2  
 MimiX Broadband

## Evaluation Board Layout: EV2 (4.0 GHz ~ 5.0 GHz)

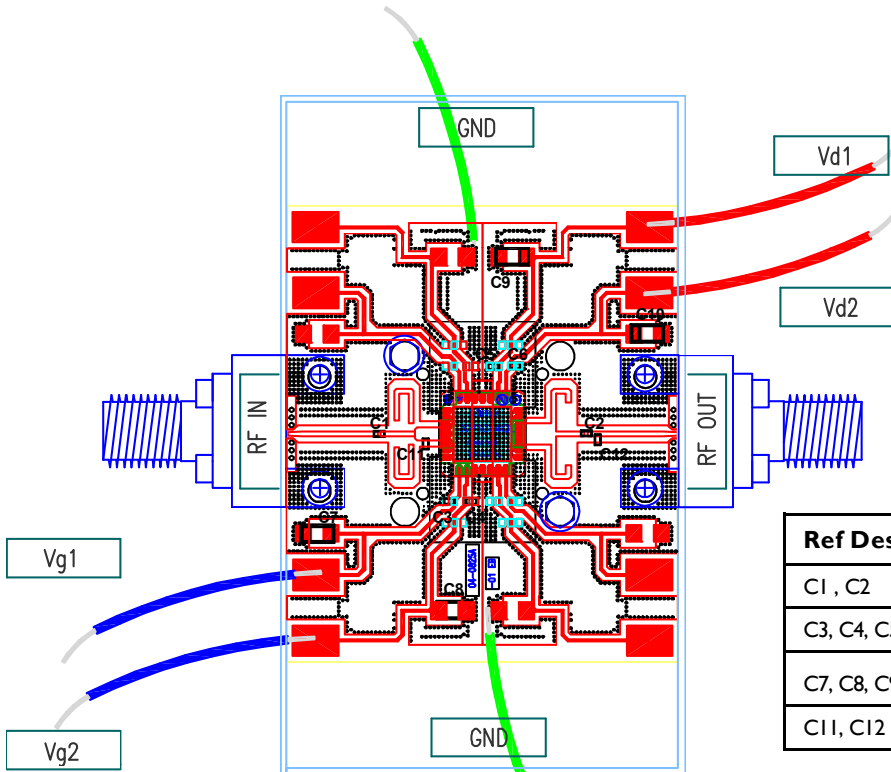

Ref Designator	Description	QTY
C1 , C2	10.0 pF 0402 Capacitor	1
C3, C4, C5, C6	1000 pF 0402 Capacitor	4
C7, C8, C9, C10	1 uF A-Case Capacitor	4
C11, C12	0.5 pF 0402 Capacitor	2

Material: Rogers 4003  
 Thickness: 8mil

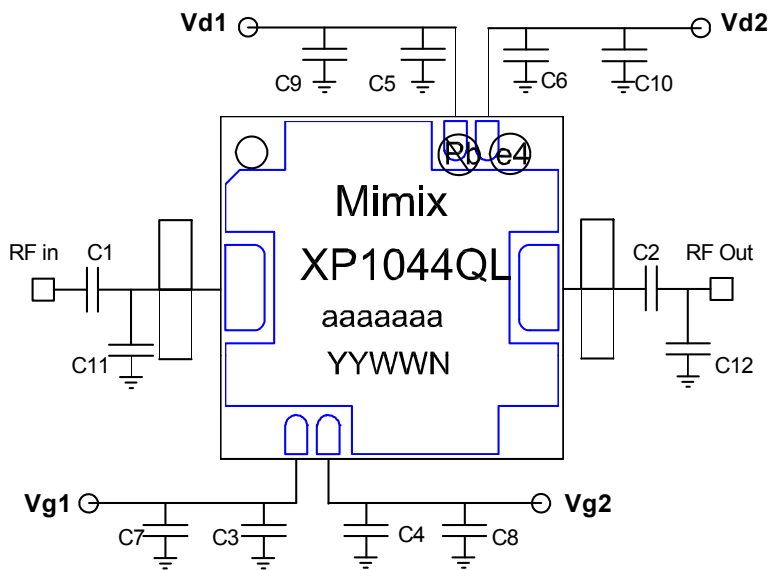

**Typical Performance Curves (EV2, Idq1 = 300 mA, Idq2 = 600 mA)**

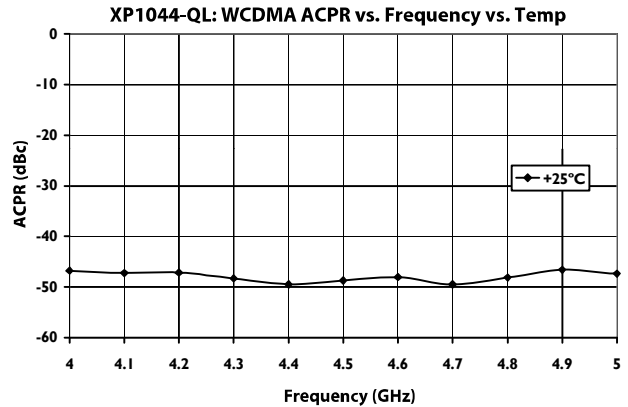
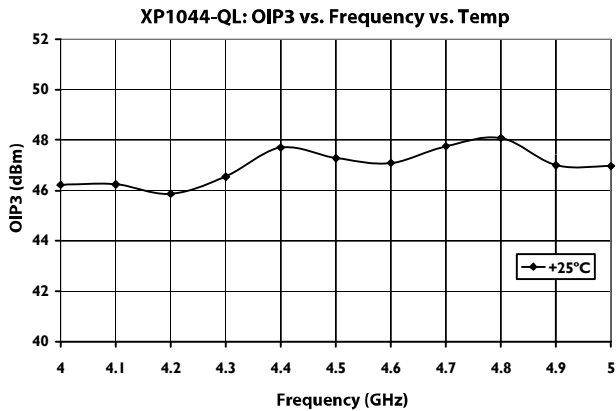
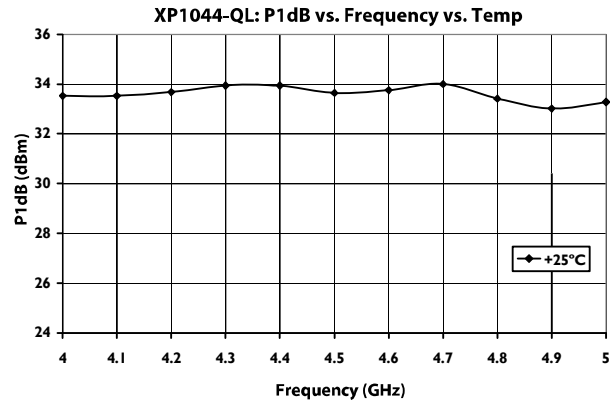
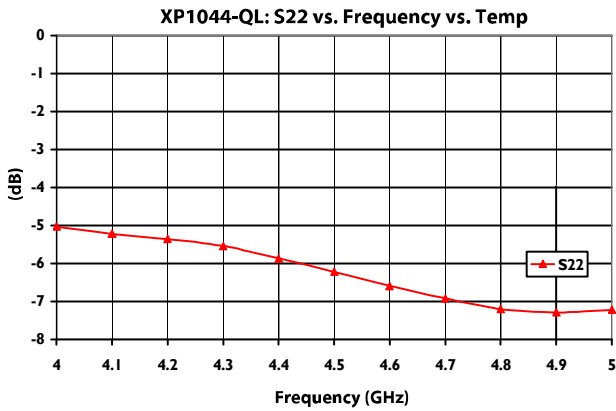
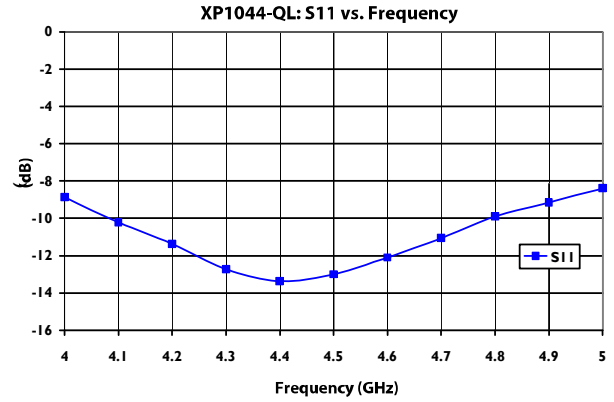
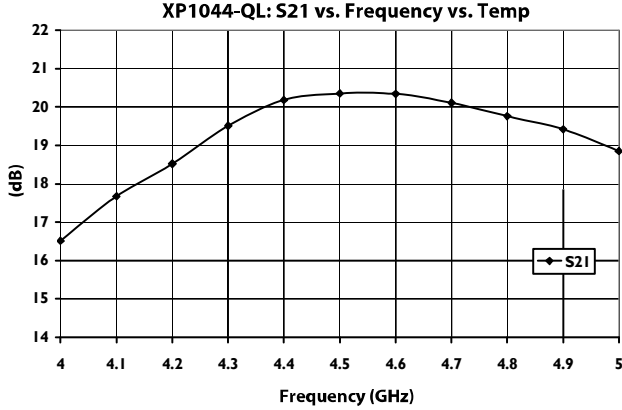



**App Note [1] Biasing** - The XP1044-QL requires power supply sequencing. Negative voltage supply (VG) needs to be turned on first and then positive voltage can be applied to the drain (VD). When turning off the device, the positive supply (VD) should be turned off first and then negative voltage (VG) can be removed.

The gate voltage is adjusted in order to set the drain current to the desired level. The gate voltage required to achieve a certain current can vary over temperature and from one device to another due to pinch-off voltage variation. Constant drain current can be achieved by implementing an active bias circuit which allows for temperature compensation and eliminates the effect of pinch off voltage variation.

The input stage transistor periphery is half of the output stage transistor periphery and therefore the gate voltages needed to set the first stage current to 300mA and the second stage current to 600mA are the same. The gate voltages can be connected together and a single active bias circuit can be implemented adding a total of 6 components at a cost of approximately \$0.15.

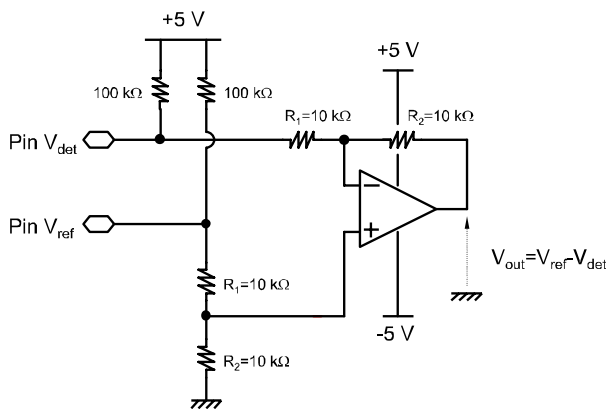

### Typical Application

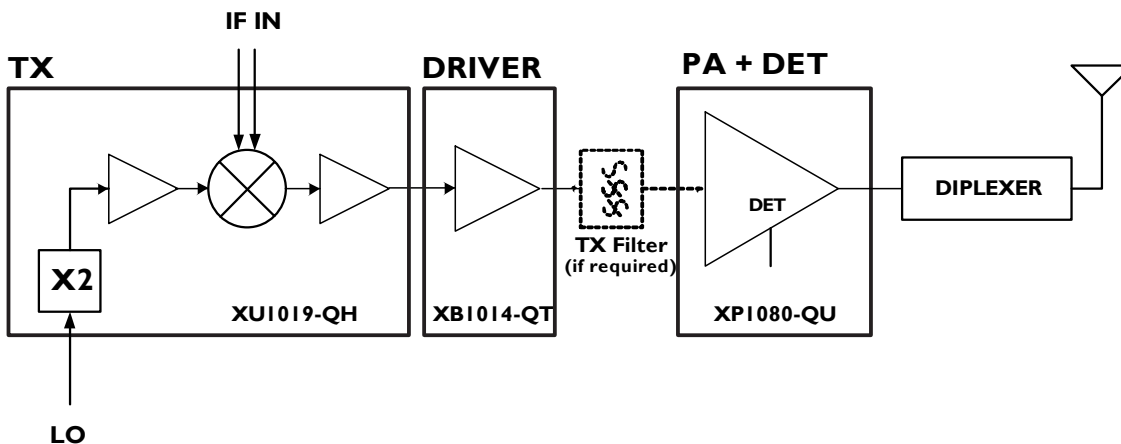

## Lead-Free Package Dimensions/Layout

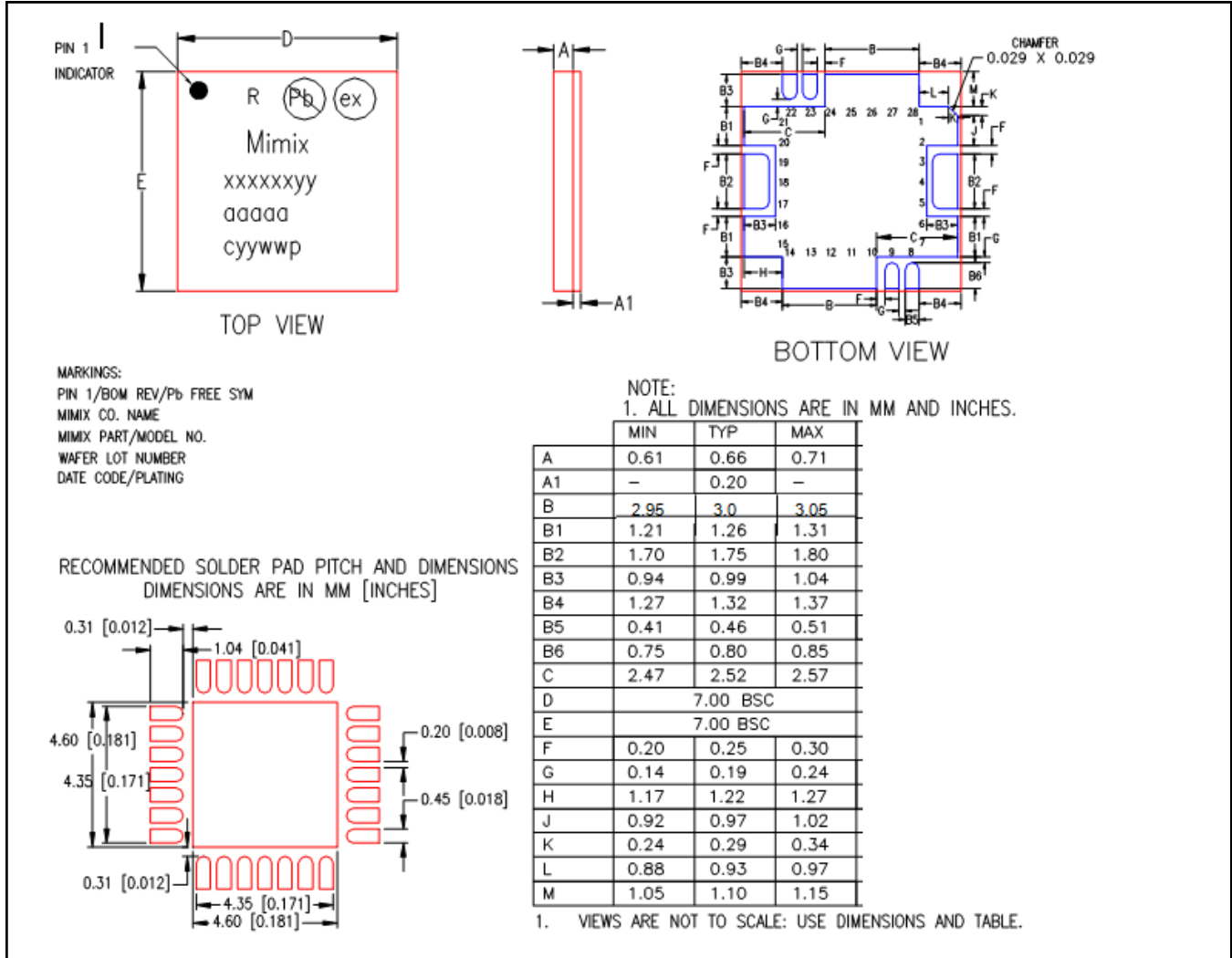

## Handling Procedures

Please observe the following precautions to avoid damage:

## Static Sensitivity

Gallium Arsenide Integrated Circuits are sensitive to electrostatic discharge (ESD) and can be damaged by static electricity. Proper ESD control techniques should be used when handling these class 2 devices.



Компания «ЭлектроПласт» предлагает заключение долгосрочных отношений при поставках импортных электронных компонентов на взаимовыгодных условиях!

Наши преимущества:

- Оперативные поставки широкого спектра электронных компонентов отечественного и импортного производства напрямую от производителей и с крупнейших мировых складов;
- Поставка более 17-ти миллионов наименований электронных компонентов;
- Поставка сложных, дефицитных, либо снятых с производства позиций;
- Оперативные сроки поставки под заказ (от 5 рабочих дней);
- Экспресс доставка в любую точку России;
- Техническая поддержка проекта, помощь в подборе аналогов, поставка прототипов;
- Система менеджмента качества сертифицирована по Международному стандарту ISO 9001;
- Лицензия ФСБ на осуществление работ с использованием сведений, составляющих государственную тайну;
- Поставка специализированных компонентов (Xilinx, Altera, Analog Devices, Intersil, Interpoint, Microsemi, Aeroflex, Peregrine, Syfer, Eurofarad, Texas Instrument, Miteq, Cobham, E2V, MA-COM, Hittite, Mini-Circuits, General Dynamics и др.);

Помимо этого, одним из направлений компании «ЭлектроПласт» является направление «Источники питания». Мы предлагаем Вам помощь Конструкторского отдела:

- Подбор оптимального решения, техническое обоснование при выборе компонента;
- Подбор аналогов;
- Консультации по применению компонента;
- Поставка образцов и прототипов;
- Техническая поддержка проекта;
- Защита от снятия компонента с производства.



#### Как с нами связаться

**Телефон:** 8 (812) 309 58 32 (многоканальный)

**Факс:** 8 (812) 320-02-42

**Электронная почта:** [org@eplast1.ru](mailto:org@eplast1.ru)

**Адрес:** 198099, г. Санкт-Петербург, ул. Калинина, дом 2, корпус 4, литера А.