

NEW

**Chip Attenuator
0404**

Type: **EXB24AT (Unbalanced π type)**



Type: **EXB24AB (Balanced O type)**



■ **Features**

EXB24AT type : Unbalanced π type

- Unbalanced π type attenuator circuit in one chip(1.0 mm × 1.0 mm)
- Mounting occupation area reduction : about 50 % reduction compared with an attenuator circuit consisting of three 0402 chip resistors, almost equal to an attenuator circuit consisting of three 0201 chip resistors
- Mounting cost reduction : Mounting times 3 times → 1 time
- Attenuation : 1 dB to 10 dB

EXB24AB type : Balanced O type

- Balanced O type attenuator circuit in one chip(1.0 mm × 1.0 mm)
- Mounting occupation area reduction : about 64 % reduction compared with an attenuator circuit consisting of four 0402 chip resistors, about 26 % reduction compared with attenuator circuit consisting of four 0201 chip resistors
- Mounting cost reduction : Mounting times 4 times → 1 time
- Attenuation : 0 dB to 10 dB

■ **Recommended Applications**

- Attenuation / level control / impedance matching of high frequency signals of communication equipment; cellular phones(GSM, CDMA, PDC, etc.), PHS, PDA, for example.

■ Explanation of Part Numbers

● EXB24AT type : Unbalanced π type

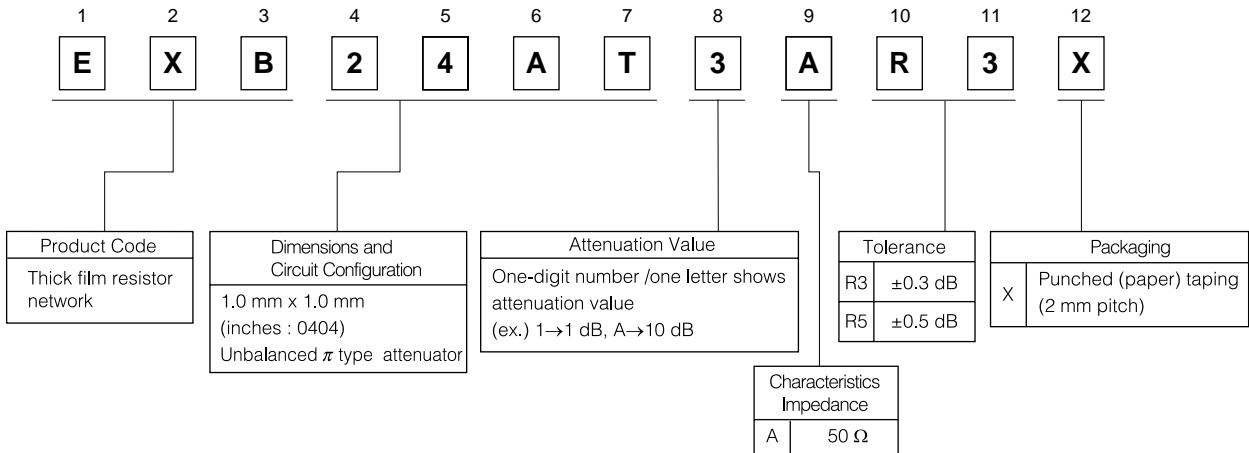

● EXB24AB type : Balanced O type

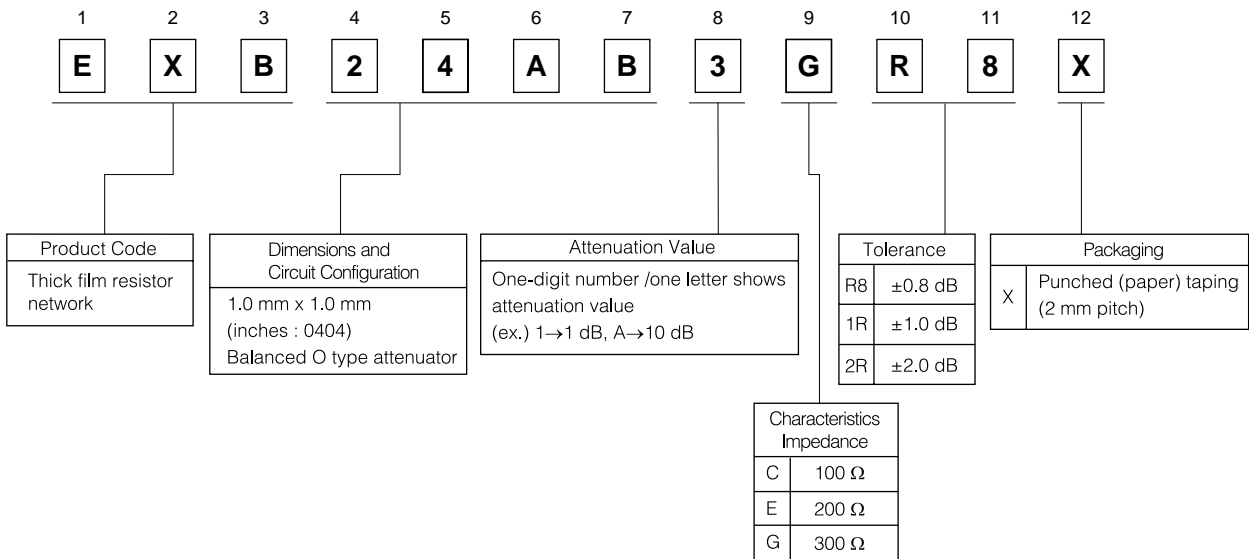

■ Attenuation-Frequency Characteristics (typical) (EXB24AT type)

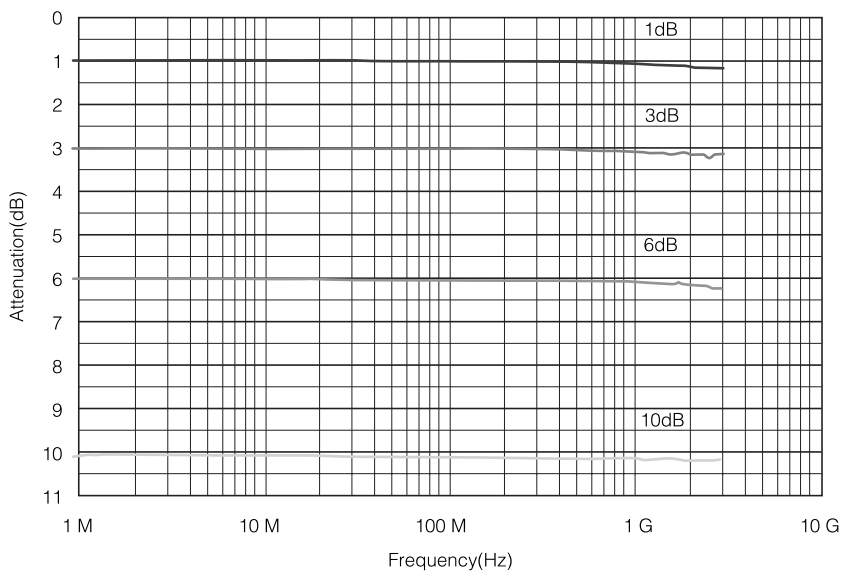

NEW

■ Construction

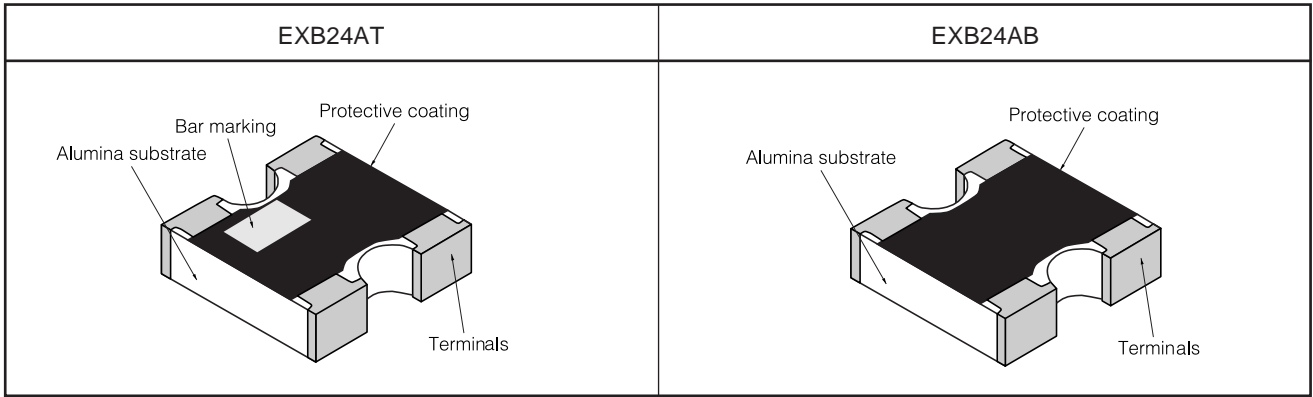

■ Circuit Configuration

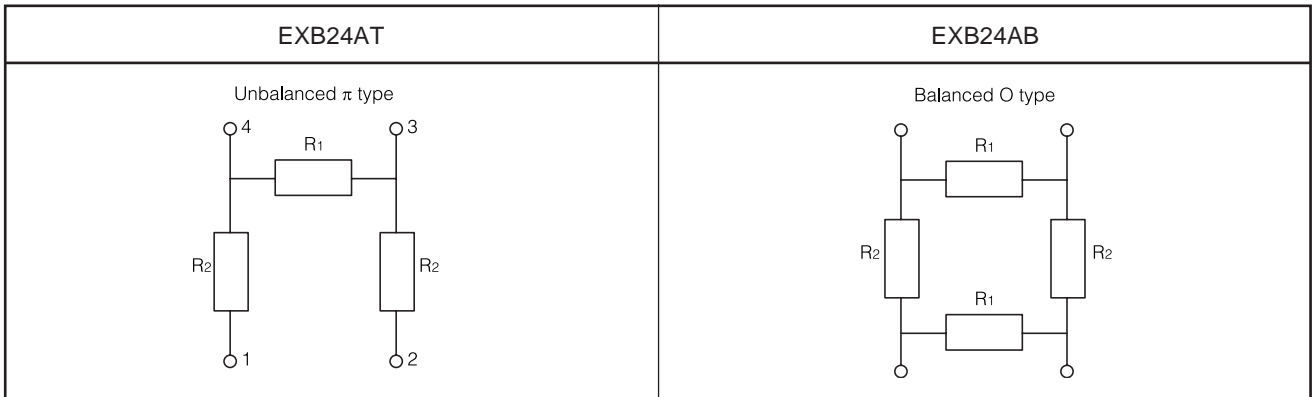

■ Dimensions (not to scale)

EXB24AT	EXB24AB																																				
<table border="1" style="width: 100%; border-collapse: collapse;"> <thead> <tr> <th>Dimensions (mm)</th> <th>L</th> <th>W</th> <th>T</th> <th>A</th> <th>B</th> </tr> </thead> <tbody> <tr> <td></td> <td>1.00^{+0.10}</td> <td>1.00^{+0.10}</td> <td>0.35^{+0.10}</td> <td>0.33^{+0.10}</td> <td>0.15^{+0.10}</td> </tr> </tbody> </table> <table border="1" style="width: 100%; border-collapse: collapse;"> <thead> <tr> <th>Dimensions (mm)</th> <th>C</th> <th>P (typical value)</th> </tr> </thead> <tbody> <tr> <td></td> <td>0.25^{+0.10}</td> <td>0.65</td> </tr> </tbody> </table>	Dimensions (mm)	L	W	T	A	B		1.00 ^{+0.10}	1.00 ^{+0.10}	0.35 ^{+0.10}	0.33 ^{+0.10}	0.15 ^{+0.10}	Dimensions (mm)	C	P (typical value)		0.25 ^{+0.10}	0.65	<table border="1" style="width: 100%; border-collapse: collapse;"> <thead> <tr> <th>Dimensions (mm)</th> <th>L</th> <th>W</th> <th>T</th> <th>A</th> <th>B</th> </tr> </thead> <tbody> <tr> <td></td> <td>1.00^{+0.10}</td> <td>1.00^{+0.10}</td> <td>0.35^{+0.10}</td> <td>0.33^{+0.10}</td> <td>0.15^{+0.10}</td> </tr> </tbody> </table> <table border="1" style="width: 100%; border-collapse: collapse;"> <thead> <tr> <th>Dimensions (mm)</th> <th>C</th> <th>P (typical value)</th> </tr> </thead> <tbody> <tr> <td></td> <td>0.30^{+0.10}</td> <td>0.65</td> </tr> </tbody> </table>	Dimensions (mm)	L	W	T	A	B		1.00 ^{+0.10}	1.00 ^{+0.10}	0.35 ^{+0.10}	0.33 ^{+0.10}	0.15 ^{+0.10}	Dimensions (mm)	C	P (typical value)		0.30 ^{+0.10}	0.65
Dimensions (mm)	L	W	T	A	B																																
	1.00 ^{+0.10}	1.00 ^{+0.10}	0.35 ^{+0.10}	0.33 ^{+0.10}	0.15 ^{+0.10}																																
Dimensions (mm)	C	P (typical value)																																			
	0.25 ^{+0.10}	0.65																																			
Dimensions (mm)	L	W	T	A	B																																
	1.00 ^{+0.10}	1.00 ^{+0.10}	0.35 ^{+0.10}	0.33 ^{+0.10}	0.15 ^{+0.10}																																
Dimensions (mm)	C	P (typical value)																																			
	0.30 ^{+0.10}	0.65																																			
<p><Marking Configuration> The bar marking for recognizing terminal direction is located on the side of terminal 4.</p>																																					

■ Ratings

Item	EXB24AT	EXB24AB
Attenuation Value	1 dB, 2 dB, 3 dB, 4 dB, 5 dB, 6 dB, 10 dB*	0 dB, 1 dB, 2 dB, 3 dB, 6 dB, 10 dB*
Attenuation Value Tolerance	1 dB, 2 dB, 3 dB, 4 dB, 5 dB : ± 0.3 dB 6 dB, 10 dB : ± 0.5 dB	0 dB to 3 dB : ± 0.8 dB 6 dB : ± 1.0 dB 10 dB : ± 2.0 dB
Characteristic Impedance	50 Ω*	100 Ω, 200 Ω, 300 Ω*
Power Rating	0.04 W /package	0.04 W /package
Frequency Range	DC to 2 GHz	DC to 2.5 GHz
VSWR (Voltage Standing Wave Ratio)	1.3 Max.	1.2 Max.(typical value) 1.5 Max.(0 dB, typical value)
Number of Resistors	3 resistors	4 resistors
Number of Terminals	4 terminals	4 terminals
Category Temperature Range (Operating Temperature Range)	-55 °C to +125 °C	-55 °C to +125 °C

*Please inquire about the other attenuator value / characteristics impedance.

Power Derating Curve

For resistors operated in ambient temperature above 70°C, power rating shall be derated in accordance with the figure on the right.

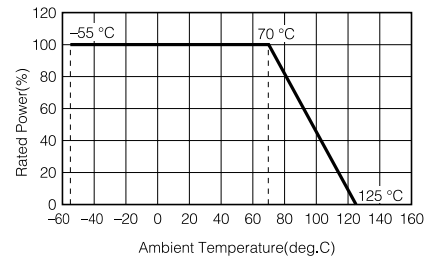

■ Packaging Methods

● Standard Quantity

Type (inches)	Thickness (mm)	Weight (mg)	Punched (Paper) Taping (2 mm Pitch)
EXB24AT/AB (0404)	0.35	1.1	10000 pcs./reel

■ Taping Dimensions

● Taping Reel

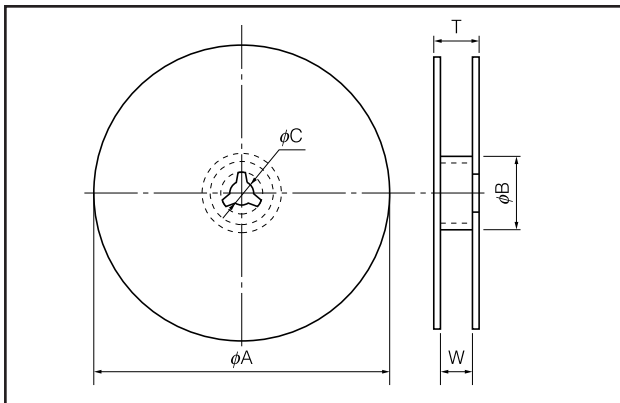

Dimensions (mm)	φA	φB	φC	W	T
	180.0 ^{+0.0} _{-3.0}	60 min.	13.0 ^{+1.0}	9.0 ^{+1.0}	11.4 ^{+2.0}

● Punched (Paper) Taping

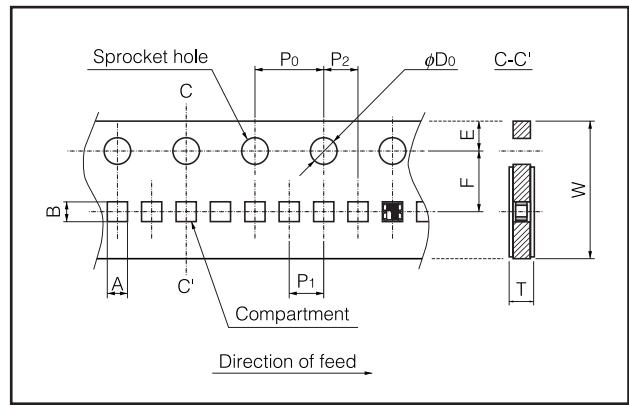

Dimensions (mm)	A	B	W	F	E
	1.20 ^{+0.05}	1.20 ^{+0.05}	8.00 ^{+0.20}	3.50 ^{+0.05}	1.75 ^{+0.10}

Dimensions (mm)	P ₀	P ₁	P ₂	φD ₀	T
	4.00 ^{+0.10}	2.00 ^{+0.10}	2.00 ^{+0.05}	1.50 ^{+0.10} ₀	0.45 ^{+0.10}

<Product direction in the chip pocket of carrier tape>
Products shall be sealed so as to locate the terminal 1 and 2 on the side of feeding direction in the chip pocket.

■Recommend Land Pattern

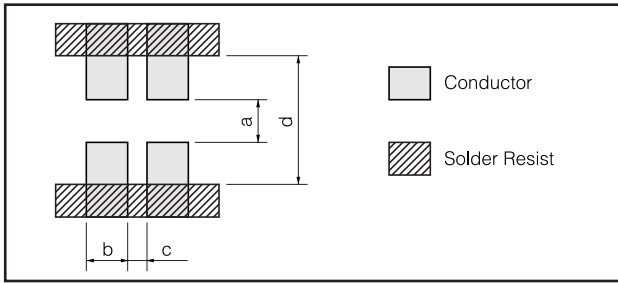

Dimensions (mm)	a	b	c	d
	0.5	0.35 to 0.4	0.3	1.4 to 1.5

⚠Safety Precautions

1. Soldering

Recommendation for soldering method is noted below.

●Reflow soldering

Precautions and recommendations are described below.

●Please inquire with us when you use the different conditions.

●Please measure a temperature of terminations and study the solderability for every type of board before using.

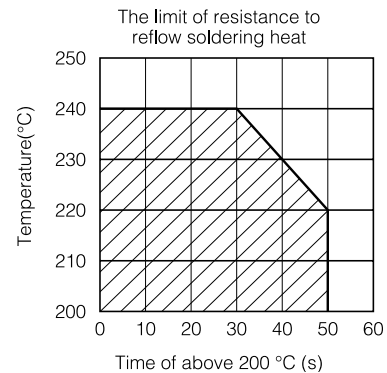
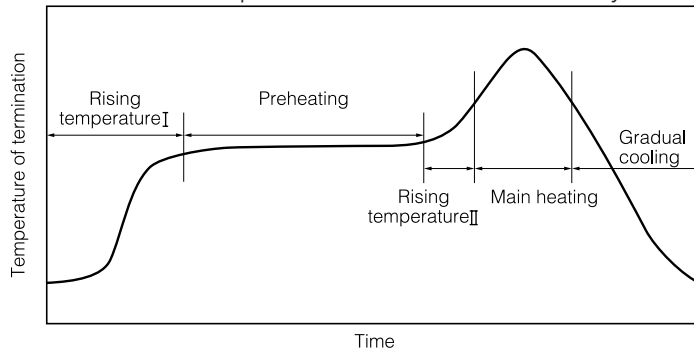

Rising temperature I	The normal to Preheating temperature	30 s to 60 s
Preheating	140 °C to 160 °C	60 s to 120 s
Rising temperature II	Preheating to 200 °C	20 s to 40 s
Main heating	(cf. The limits of resistance to reflow soldering heat)	
Gradual cooling	200 °C to 100 °C	1 °C/s to 4 °C/s

(Reflow soldering shall be within two times.)

● Flow soldering

We cannot recommend the flow soldering, because a solder bridge may occur owing to narrow 0.65 mm pitch.

● Iron soldering

①Solder at 280 °C max. and 3 seconds max. with the soldering iron tip.

②The soldering iron tip shall not touch the protective coating of the part.

● Use rosin type flux. Do not use high-activity flux (the chlorine content is 0.2 wt % or more).

● Allow enough preheating so that the difference of soldering temperature and temperature of surface of the part is 100 °C or less. This temperature difference shall be kept in rapid cooling by immersion into solvent.

● Use of more solder results in more mechanical stress to the part resulting in cracking or impaired characteristics. Avoid excessive amount of solder.

2. Cleaning

● Residual flux after board washing may cause solder migration. Carefully check the status of board washing.

Study the type and amount of flux to be used when no washing is made. Study the type of water-soluble flux and cleaning agent and drying condition when water washing is done. Confirm they will not cause any trouble.

3. Others

● Take necessary precautions to avoid any abnormal stress caused by bending of board.

● Do not use the product in dewy atmosphere.

Mouser Electronics

Authorized Distributor

Click to View Pricing, Inventory, Delivery & Lifecycle Information:

[Panasonic:](#)

[EXB-24AB1CR8X](#) [EXB-24AB2CR8X](#) [EXB-24AB3CR8X](#)



Компания «ЭлектроПласт» предлагает заключение долгосрочных отношений при поставках импортных электронных компонентов на взаимовыгодных условиях!

Наши преимущества:

- Оперативные поставки широкого спектра электронных компонентов отечественного и импортного производства напрямую от производителей и с крупнейших мировых складов;
- Поставка более 17-ти миллионов наименований электронных компонентов;
- Поставка сложных, дефицитных, либо снятых с производства позиций;
- Оперативные сроки поставки под заказ (от 5 рабочих дней);
- Экспресс доставка в любую точку России;
- Техническая поддержка проекта, помощь в подборе аналогов, поставка прототипов;
- Система менеджмента качества сертифицирована по Международному стандарту ISO 9001;
- Лицензия ФСБ на осуществление работ с использованием сведений, составляющих государственную тайну;
- Поставка специализированных компонентов (Xilinx, Altera, Analog Devices, Intersil, Interpoint, Microsemi, Aeroflex, Peregrine, Syfer, Eurofarad, Texas Instrument, Miteq, Cobham, E2V, MA-COM, Hittite, Mini-Circuits, General Dynamics и др.);

Помимо этого, одним из направлений компании «ЭлектроПласт» является направление «Источники питания». Мы предлагаем Вам помощь Конструкторского отдела:

- Подбор оптимального решения, техническое обоснование при выборе компонента;
- Подбор аналогов;
- Консультации по применению компонента;
- Поставка образцов и прототипов;
- Техническая поддержка проекта;
- Защита от снятия компонента с производства.



Как с нами связаться

Телефон: 8 (812) 309 58 32 (многоканальный)

Факс: 8 (812) 320-02-42

Электронная почта: org@eplast1.ru

Адрес: 198099, г. Санкт-Петербург, ул. Калинина, дом 2, корпус 4, литера А.