

S2S5FA0F

V_{DRM} : 600V, Cost effective
 Non-zero cross type
 Mini-Flat Package
 Phototriac Coupler for triggering



■Description

S2S5FA0F Phototriac Coupler include an infrared emitting diode (IRED) optically coupled to an output Phototriac.

These devices feature full wave control and are ideal isolated drivers for medium to high current Triacs.

SOP package provides 3.75kV isolation from input to output with superior commutative noise immunity.

■Features

1. High repetitive peak off-state voltage (V_{DRM} : 600V)
2. Non-zero crossing functionality
3. 4pin Mini-flat package
4. Superior noise immunity
(dV/dt : MIN. 500V/ μ s)
5. Double transfer mold construction
(Ideal for Flow Soldering)
6. High isolation voltage between input and output
($V_{iso(rms)}$: 3.75kV)

■Agency approvals/Compliance

1. Recognized by UL1577 (Double protection isolation), file No. E64380 (as model No. **S2S5**)
2. Approved by CSA, file No. CA95323 (as model No. **S2S5**)
3. Optionary available VDE Approved^(*)
(DIN EN 60747-5-5), file No. 40009162 (as model No. **S2S5**)
4. Package resin : UL flammability grade (94V-0)

^(*) DIN EN60747-5-5 : successor standard of DIN EN60747-5-2
 UP to Date code "S1" (January 2004), approval of DIN EN60747-5-2.
 From Date code "E4" (April 2014), approval of DIN EN60747-5-5

■Applications

1. Triggering for Triacs used to switch on and off devices which require AC loads.
 For example heaters, fans, motors, solenoids, and valves.
2. Triggering for Triacs used for implementing phase control in applications such as lighting control and temperature control (HVAC).
3. AC line control in power supply applications.

Notice The content of data sheet is subject to change without prior notice.

In the absence of confirmation by device specification sheets, SHARP takes no responsibility for any defects that may occur in equipment using any SHARP devices shown in catalogs, data books, etc. Contact SHARP in order to obtain the latest device specification sheets before using any SHARP device.

Sheet No.: OP14019EN

■ Outline

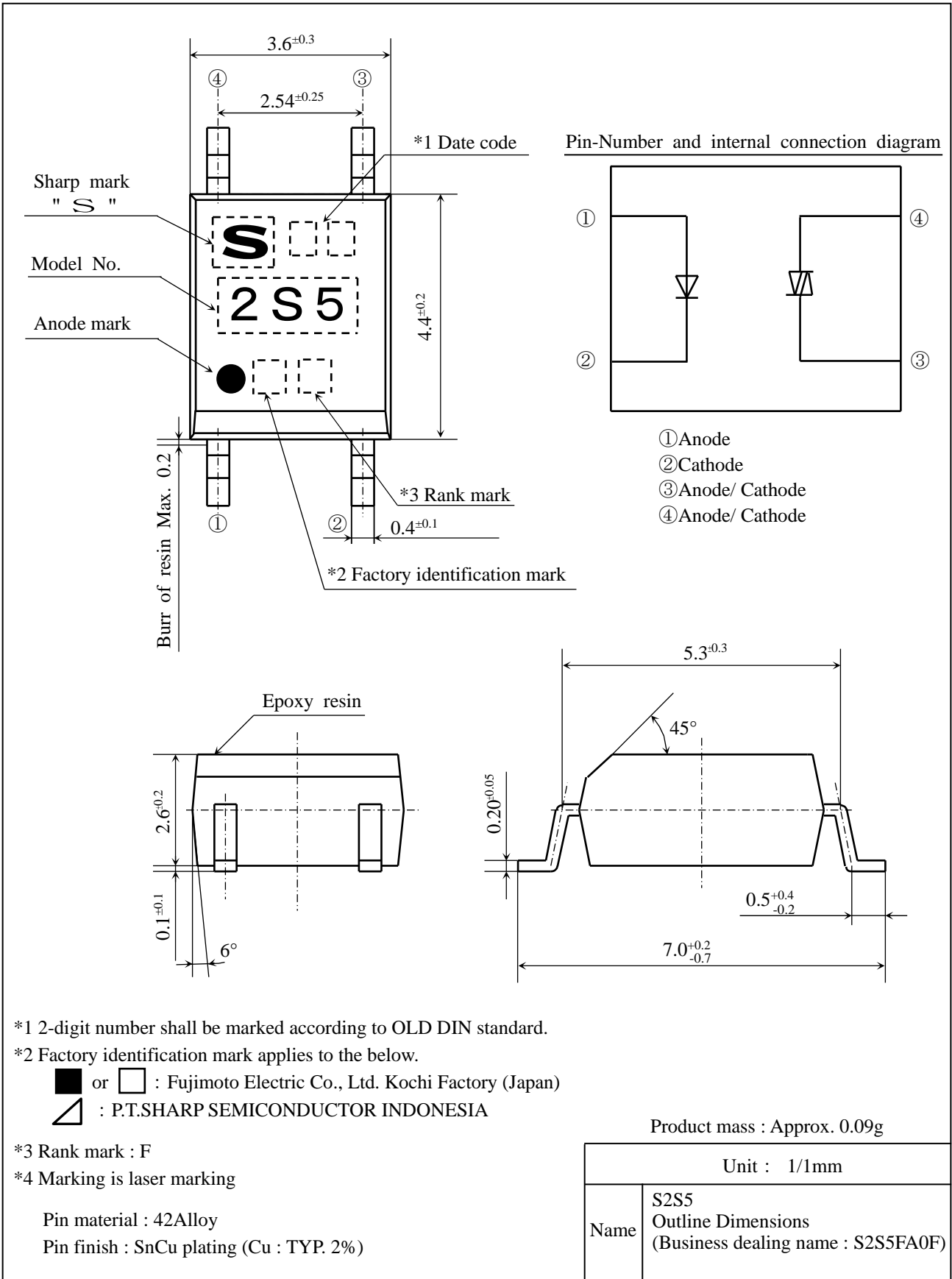

*1 2-digit number shall be marked according to OLD DIN standard.

*2 Factory identification mark applies to the below.

- or □ : Fujimoto Electric Co., Ltd. Kochi Factory (Japan)
- ▴ : P.T.SHARP SEMICONDUCTOR INDONESIA

*3 Rank mark : F

*4 Marking is laser marking

Pin material : 42Alloy

Pin finish : SnCu plating (Cu : TYP. 2%)

■ **Absolute maximum ratings**

Ta=25°C

Parameter		Symbol	Ratings	Unit
Input	Forward current *1	I _F	50	mA
	Reverse voltage	V _R	6	V
Output	RMS on-state current *1	I _{T(rms)}	0.05	A
	Peak one cycle surge current	I _{surge}	0.6(50Hz sine wave)	A
	Repetitive peak off-state voltage	V _{DRM}	600	V
Isolation voltage *2		V _{iso(rms)}	3.75	kV
Operating temperature		T _{opr}	-30 ~ +100	°C
Storage temperature		T _{stg}	-40 ~ +125	°C
Soldering temperature		T _{sol}	260 (10s)	°C

*1 The derating factors of absolute maximum rating due to ambient temperature are shown in Fig.1,2.

*2 AC for 1min, 40 to 60%RH

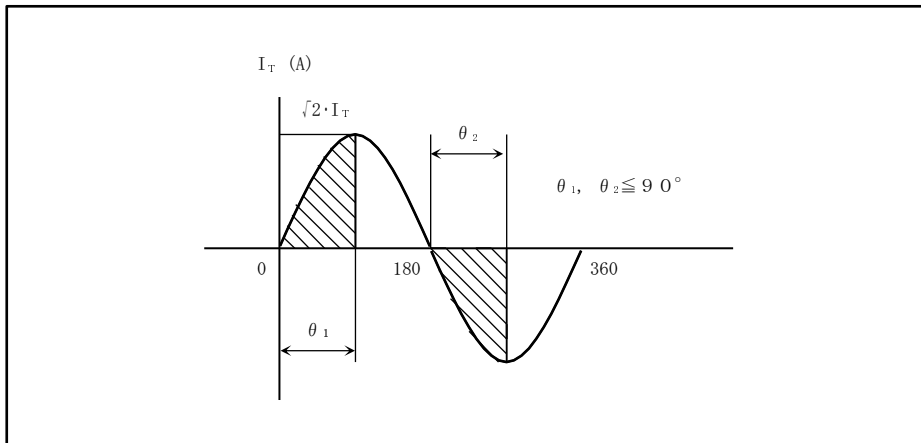

■ **Electrical characteristics**

Ta=25°C

Parameter		Symbol	Conditions	MIN.	TYP.	MAX.	Unit
Input	Forward voltage	V _F	I _F =20mA	-	1.2	1.4	V
	Reverse current	I _R	V _R =3V	-	-	10	μA
Output	Repetitive peak off-state current	I _{DRM}	V _D =V _{DRM}	-	-	1	μA
	On-state voltage	V _T	I _T =0.05A	-	-	2.5	V
	Holding current	I _H	V _D =6V	0.1	-	3.5	mA
	Critical rate of rise of off-state voltage	dv/dt	V _D =1/√2 · V _{DRM}	500	-	-	V/μs
Transfer characteristics	Minimum trigger current	I _{FT}	V _D =6V, R _L =100Ω	-	-	10	mA
	Isolation resistance	R _{ISO}	DC500V 40~60%RH	5×10 ¹⁰	10 ¹¹	-	Ω
	Turn on time	t _{ON}	V _D =6V, R _L =100Ω I _F =20mA	-	-	100	μs

Fig.1 Forward current vs. ambient temperature

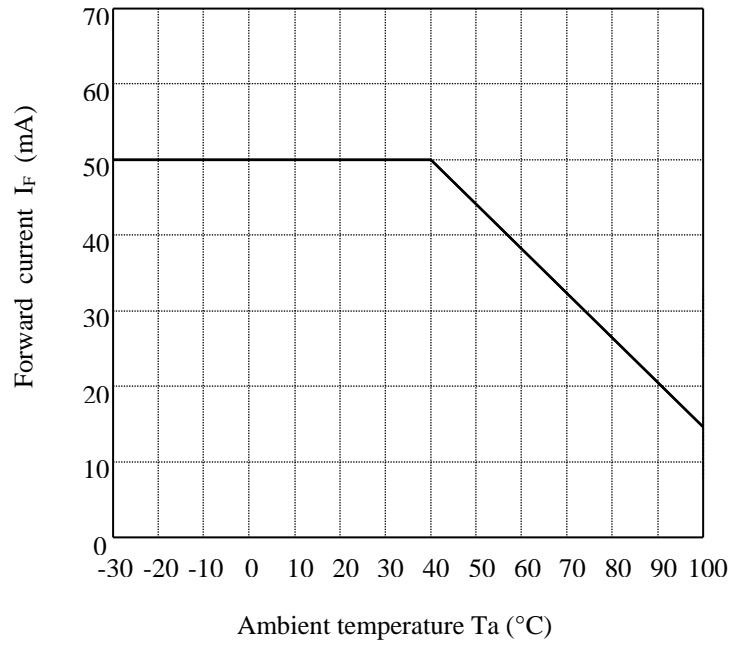
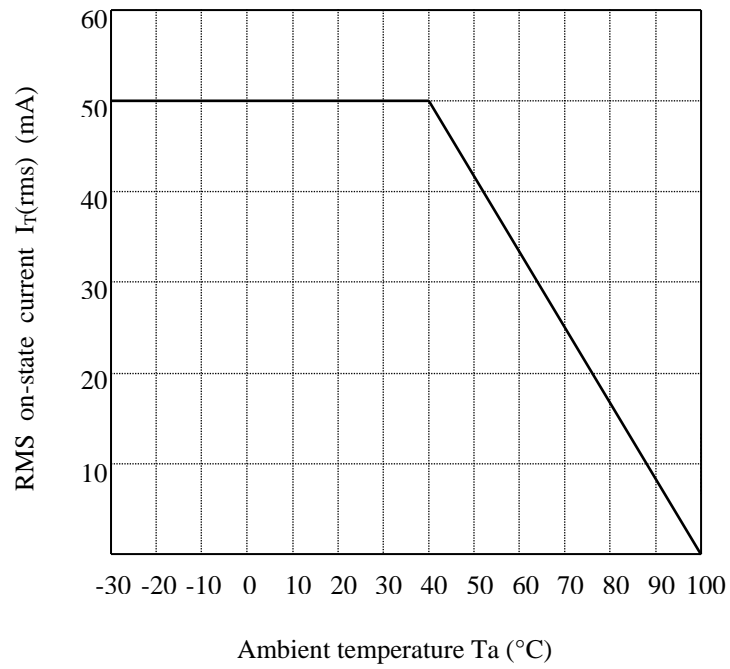



Fig.2 RMS on-state current vs. ambient temperature



■ **Supplement**

- The business dealing name used for this product when ordered or delivered shall be S2S5FA0F.
- Refer to the attached sheet, page 7 to 9.
- Isolation voltage shall be measured in the following method.
 - (1) Short between pins 1 to 2 on the primary side and between pins 3 to 4 on the secondary side.
 - (2) The dielectric withstanding tester with zero-cross circuit shall be used.
 - (3) The wave form of applied voltage shall be a sine wave.
(It is recommended that the isolation voltage be measured in insulation oil.)
- This Model is approved by UL and CSA
 Approved Model No. : S2S5
 UL File No. : E64380
 CSA File No. : CA95323
 CSA approved mark "  " shall be indicated on minimum unit package.
- This product is not designed against irradiation.
 This product is assembled with electrical input and output.
 This product incorporates non-coherent light emitting diode.
- ODS materials
 - (1) This product shall not contain the following materials.
 - (2) Also, the following materials shall not be used in the production process for this product.
 Materials for ODS : CFCs, Halon, Carbon tetrachloride, 1.1.1-Trichloroethane (Methyl chloroform)
- Specified brominated flame retardants (PBB and PBDE) are not used in this device at all.
- Compliance with each regulation
 - (1) The RoHS directive(2002/95/EC)
 - (2) This product complies with the RoHS directive(2002/95/EC)
 Object substances: mercury, lead (except for lead in high melting temperature type solders*1 and glass of electronic components), cadmium, hexavalent chromium, polybrominated biphenyls (PBB) and polybrominated diphenyl ethers (PBDE)
- Content of six substances specified in Management Methods for Control of Pollution Caused by Electronic Information Products Regulation (Chinese : 电子信息产品污染控制管理办法)

Category	Toxic and hazardous substances					
	Lead (Pb)	Mercury (Hg)	Cadmium (Cd)	Hexavalent chromium (Cr ⁶⁺)	Polybrominated biphenyls (PBB)	Polybrominated biphenyl ethers (PBDE)
Phototriac coupler	✓	✓	✓	✓	✓	✓

✓ : indicates that the content of the toxic and hazardous substance in all the homogeneous materials of the part is below the concentration limit requirement as described in SJ/T 11363-2006 standard .

■Notes

- Circuit design

- (1) The LED used in the Phototriac coupler generally decreases the light emission power by operation. In case of long operation time, please decide I_F value as 2 times or more of the Maximum value of the Minimum triggering current at circuit design with considering the decreases of the light emission power of the LED. (50%/5years)
- (2) Input current (I_F) at off-state shall be set 0.1mA or less.
- (3) In case that pulse drive is carried out, the pulse width of input signal should be 1ms or more.

- Usage

Only for triggering medium power triac and high power triac.
(This model shall be used under the condition on which power triac turns on.)

- Cleaning

- (1) Solvent cleaning : Solvent temperature 45°C or less, Immersion for 3 min or less
- (2) Ultrasonic cleaning : The effect to device by ultrasonic cleaning differs by cleaning bath size, ultrasonic power output, cleaning time, PCB size or device mounting condition etc. Please test it in actual using condition and confirm that doesn't occur any defect before starting the ultrasonic cleaning.
- (3) Applicable solvents are as follows.
Applicable solvent : Ethyl alcohol, Methyl alcohol, Isopropyl alcohol
When the other solvent is used, there are cases that the packaging resin is eroded. Please use the other solvent after thorough confirmation is performed in actual using condition.

- Precautions for Soldering Phototriac couplers

- (1) In the case of flow soldering (Whole dipping is possible.)
It is recommended that flow soldering be carried out at 260°C or less and within 10s (Pre-heating : 100 to 150°C, 30 to 80s). (2 times or less)
- (2) It is recommended to be done at the temperature and the time within the temperature profile as shown in the figure below. (2 times or less)

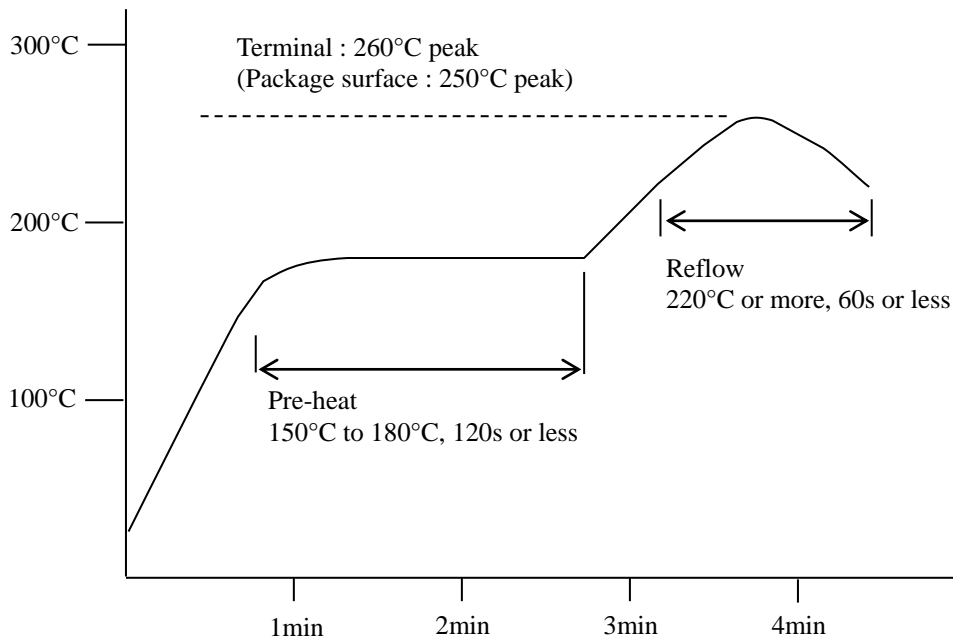

- (3) In the case of hand soldering

It is recommended that hand soldering be carried out at 400°C or less and within 3s : Within 2 times

- (4) Other precautions

Depending on equipment and soldering conditions (temperature, Using solder etc.), the effect to junction between PCB and lead pins of photocoupler is different. Please confirm that there is no problem on the actual use conditions.

■ Package specifications

- Taping conditions
 - (1) Tape structure and Dimensions (Refer to the attached sheet, Page 8)
The carrier tape has the heat pressed structure of A-PET material carries tape and three layers cover tape (PET material base).
 - (2) Reel structure and Dimensions (Refer to the attached sheet, Page 8)
The taping reel shall be of plastic (PS material).
 - (3) Direction of product insertion (Refer to attached sheet, Page 9)
 - (4) The cover tape and carrier tape in one reel shall be joint less.
 - (5) To repair taped failure devices, cutting a bottom of carrier tape with a cutter.
After replacing the cut portion shall be sealed with adhesive tape.
- Adhesiveness of cover tape
The exfoliation force between carrier tape and cover tape shall be 0.2N to 0.7N for the angle 160° to 180°
- Rolling method and quantity
Wind the tape back on the reel so that the cover tape will be outside the tape.
Attach more than 20cm of blank tape to the trailer and the leader of the tape and fix the both ends with adhesive tape. One reel basically shall contain 3,000pcs.
- Outer packing appearance (Refer to attached sheet, Page 9)
- Marking
The label with following information shall be pasted at appointed place of the outer packaging case.
* Model No.* (Business dealing name) * lot No. * quantity * country of origin
* Company name * inspection date specified
- Storage condition
Taped products shall be stored at the temperature 5 to 30°C and the humidity 70%RH or less away from direct sunlight.
- Safety protection during shipping
There shall be no deformation of component or degradation of electrical characteristics due to shipping.

© Carrier tape structure and Dimensions

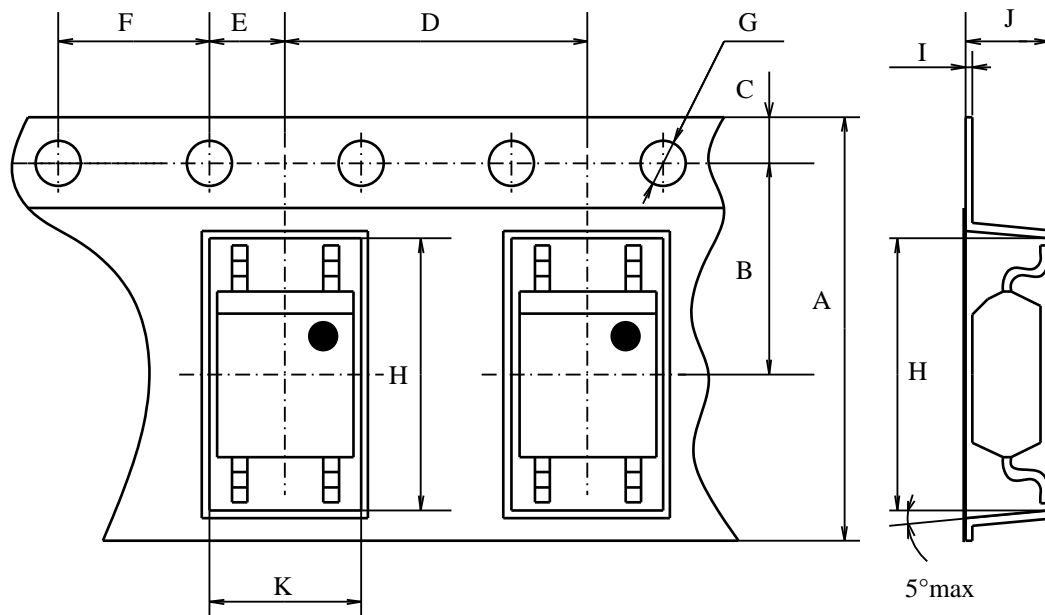

Dimensions list (Unit : mm)

A	B	C	D	E	F	G	H
12.0 ± 0.3	5.50 ± 0.05	1.75 ± 0.10	8.0 ± 0.1	2.0 ± 0.1	4.0 ± 0.1	φ 1.5 ^{+0.1} ₋₀	7.4 ± 0.1
I	J	K					
0.30 ± 0.05	3.1 ± 0.1	4.0 ± 0.1					

© Reel structure and Dimensions

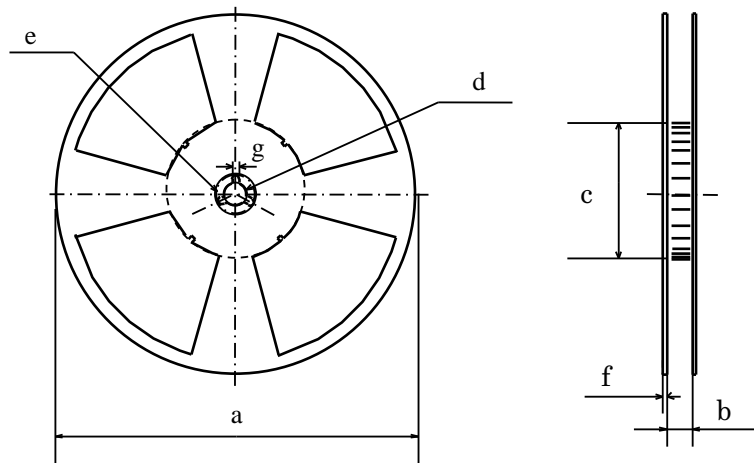

Dimensions list (Unit : mm)

a	b	c	d	e	f	g
(370)	13.5 ± 1.5	φ 100.0 ± 1.0	φ 13.0 ± 0.5	φ 21.0 ± 1.0	2.0 ± 0.5	2.0 ± 0.5

◎ Direction of product insertion

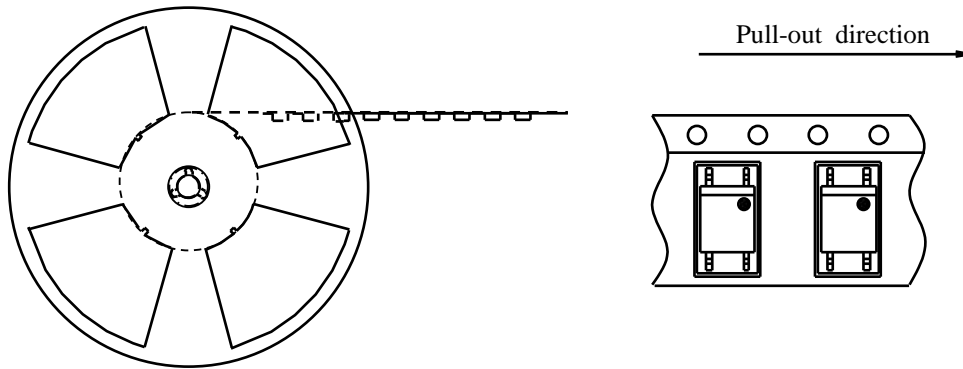

◎ Outer packing appearance

- (1) The entering 3,000 product carrier tape (reel volume) is stored in the outer packaging case.
- (2) The outer packaging case is sealed off with the craft tape, and it sticks labels on.
(four reel or less wrapping 12,000 products or less)

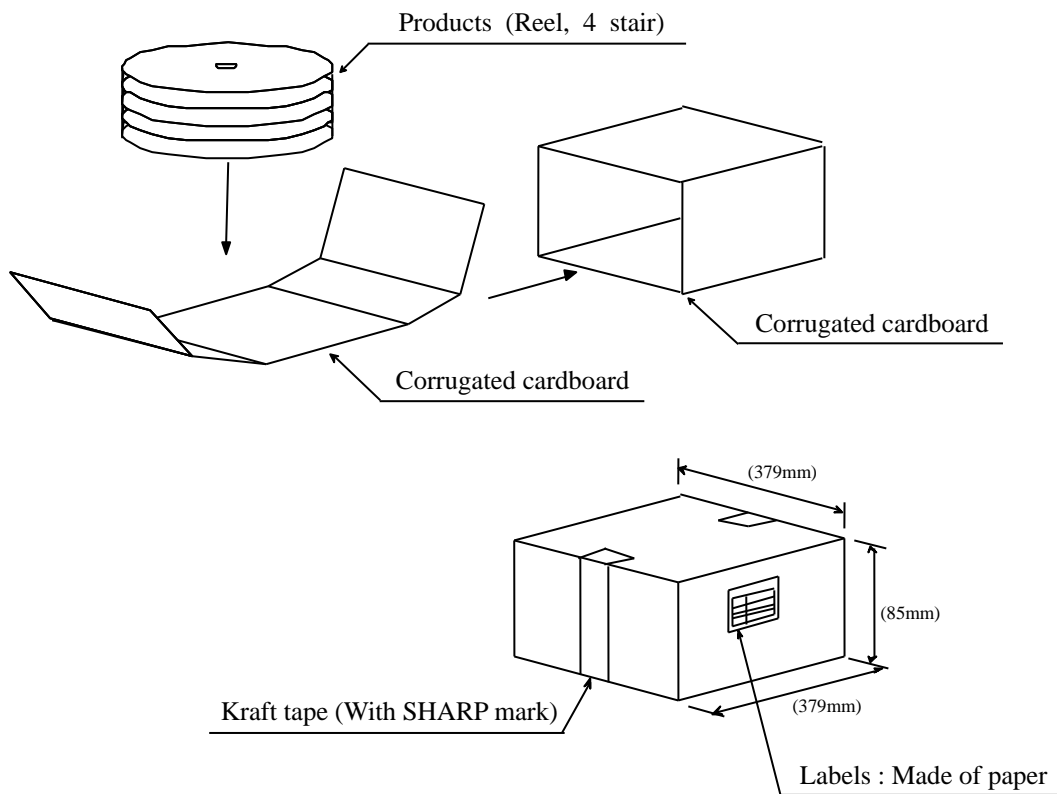

() : Reference dimensions

■ Important Notices

· The circuit application examples in this publication are provided to explain representative applications of SHARP devices and are not intended to guarantee any circuit design or license any intellectual property rights. SHARP takes no responsibility for any problems related to any intellectual property right of a third party resulting from the use of SHARP's devices.

· Contact SHARP in order to obtain the latest device specification sheets before using any SHARP device. SHARP reserves the right to make changes in the specifications, characteristics, data, materials, structure, and other contents described herein at any time without notice in order to improve design or reliability. Manufacturing locations are also subject to change without notice.

· Observe the following points when using any devices in this publication. SHARP takes no responsibility for damage caused by improper use of the devices which does not meet the conditions and absolute maximum ratings to be used specified in the relevant specification sheet nor meet the following conditions:

(i) The devices in this publication are designed for use in general electronic equipment designs such as:

- Personal computers
- Office automation equipment
- Telecommunication equipment [terminal]
- Test and measurement equipment
- Industrial control
- Audio visual equipment
- Consumer electronics

(ii) Measures such as fail-safe function and redundant design should be taken to ensure reliability and safety when SHARP devices are used for or in connection

with equipment that requires higher reliability such as:

- Transportation control and safety equipment (i.e., aircraft, trains, automobiles, etc.)
- Traffic signals
- Gas leakage sensor breakers
- Alarm equipment
- Various safety devices, etc.

(iii) SHARP devices shall not be used for or in connection with equipment that requires an extremely high level of reliability and safety such as:

- Space applications
- Telecommunication equipment [trunk lines]
- Nuclear power control equipment
- Medical and other life support equipment (e.g., scuba).

· If the SHARP devices listed in this publication fall within the scope of strategic products described in the Foreign Exchange and Foreign Trade Law of Japan, it is necessary to obtain approval to export such SHARP devices.

· This publication is the proprietary product of SHARP and is copyrighted, with all rights reserved. Under the copyright laws, no part of this publication may be reproduced or transmitted in any form or by any means, electronic or mechanical, for any purpose, in whole or in part, without the express written permission of SHARP. Express written permission is also required before any use of this publication may be made by a third party.

· Contact and consult with a SHARP representative if there are any questions about the contents of this publication.



Компания «ЭлектроПласт» предлагает заключение долгосрочных отношений при поставках импортных электронных компонентов на взаимовыгодных условиях!

Наши преимущества:

- Оперативные поставки широкого спектра электронных компонентов отечественного и импортного производства напрямую от производителей и с крупнейших мировых складов;
- Поставка более 17-ти миллионов наименований электронных компонентов;
- Поставка сложных, дефицитных, либо снятых с производства позиций;
- Оперативные сроки поставки под заказ (от 5 рабочих дней);
- Экспресс доставка в любую точку России;
- Техническая поддержка проекта, помощь в подборе аналогов, поставка прототипов;
- Система менеджмента качества сертифицирована по Международному стандарту ISO 9001;
- Лицензия ФСБ на осуществление работ с использованием сведений, составляющих государственную тайну;
- Поставка специализированных компонентов (Xilinx, Altera, Analog Devices, Intersil, Interpoint, Microsemi, Aeroflex, Peregrine, Syfer, Eurofarad, Texas Instrument, Miteq, Cobham, E2V, MA-COM, Hittite, Mini-Circuits, General Dynamics и др.);

Помимо этого, одним из направлений компании «ЭлектроПласт» является направление «Источники питания». Мы предлагаем Вам помощь Конструкторского отдела:

- Подбор оптимального решения, техническое обоснование при выборе компонента;
- Подбор аналогов;
- Консультации по применению компонента;
- Поставка образцов и прототипов;
- Техническая поддержка проекта;
- Защита от снятия компонента с производства.



Как с нами связаться

Телефон: 8 (812) 309 58 32 (многоканальный)

Факс: 8 (812) 320-02-42

Электронная почта: org@eplast1.ru

Адрес: 198099, г. Санкт-Петербург, ул. Калинина, дом 2, корпус 4, литера А.