600mA*¹ Step-down DC/DC Converter with Synchronous Rectifier

NO.EA-305-121127

OUTLINE

The RP507K001B is a CMOS-based 600mA*¹ step-down DC/DC converter with synchronous rectifier. Internally, a single converter consists of an oscillator, a reference voltage unit, an error amplifier, a switching control circuit, a soft-start circuit, an under voltage lockout (UVLO) circuit, an over current protection circuit, a thermal shutdown circuit and switching transistors.

Replacing diodes with built-in switching transistors improves the efficiency of rectification. Therefore, by simply using an inductor, resistors and capacitors as the external components, a low ripple high efficiency synchronous rectifier step-down DC/DC converter can be easily configured.

The RP507K001B has an over current protection circuit which supervises the inductor peak current in each switching cycle, and turns the high-side driver off if the current exceeds the Lx current limit. The RP507K001B also contains a thermal shutdown circuit which detects overheating of the converter and stops the converter operation to protect it from damage if the junction temperature exceeds the specified temperature.

The RP507K001B is PWM/VFM auto switching control in which mode automatically switches from PWM mode to high-efficiency VFM mode in low output current.

The RP507K001B is available in DFN(PLP)1616-6D package which achieves high-density mounting on boards. For an input capacitor (C_{IN}) and an output capacitor (C_{OUT}), the smaller sized 0402/1005 (inch/ mm) capacitor can be used. Output voltage is adjustable with external divider resistors.

*¹This is an approximate value, because output current depends on conditions and external components.

FEATURES

- Input Voltage Range 2.3V to 5.5V (Absolute maximum rating: 6.5V)
- Output Voltage Range 0.7V to 5.5V
(Note: As for 1.0V or less, input voltage range is limited.)
- Feedback Voltage Accuracy ±9mV (V_{FB}=0.6V)
- Temperature-Drift Coefficient of Feedback Voltage
..... Typ. ±100ppm/°C
- Oscillator Frequency Typ. 2.0MHz
- Maximum Duty Cycle 100%
- Built-in Driver ON Resistance Typ. Pch. 0.38Ω, Nch. 0.3Ω (V_{IN}=3.6V)
- Supply Current (at no load) Typ. 34μA
- Standby Current Max. 5μA
- UVLO Detector Threshold Typ. 2.0V
- Soft-start Time Typ. 150μs
- Lx Current Limit Circuit Typ. 1A
- Package DFN(PLP)1616-6D

APPLICATIONS

- Power source for portable equipment such as cellular, PDA, DSC, Notebook PC, smartphone
- Power source for Li-ion battery-used equipment

BLOCK DIAGRAMS

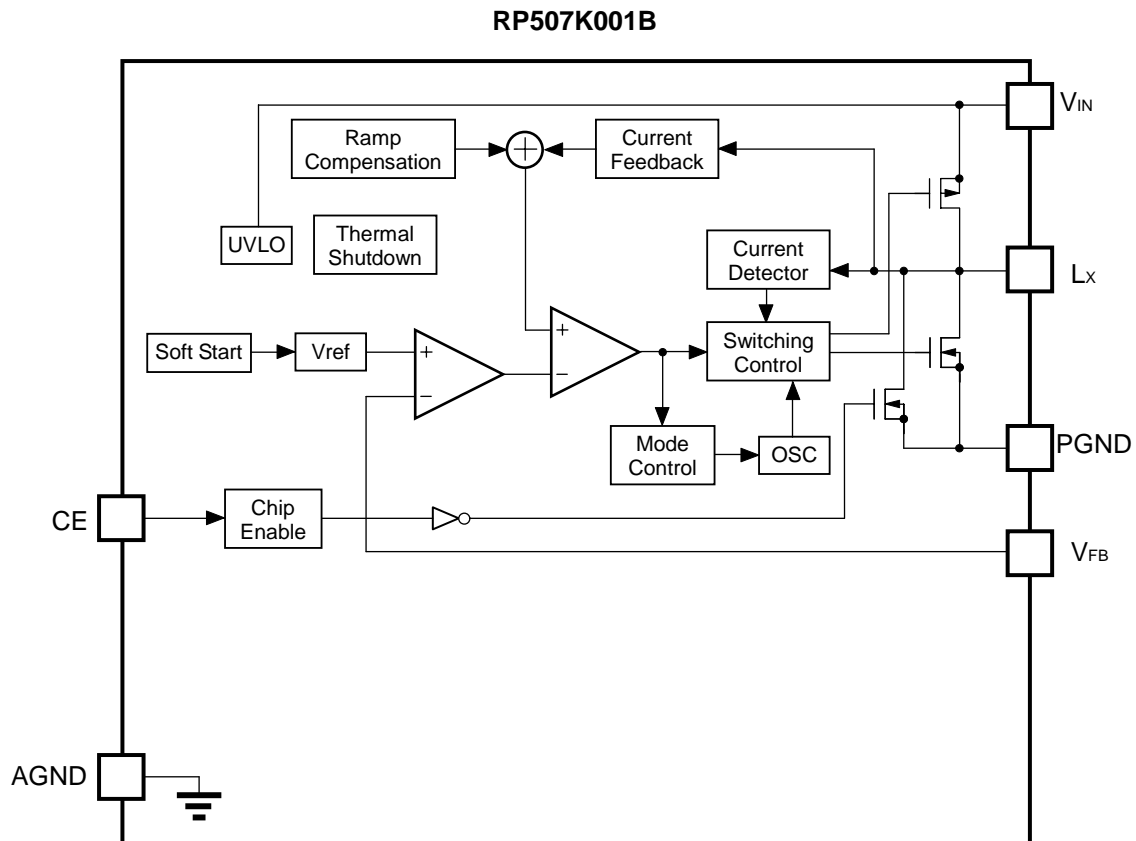

SELECTION GUIDE

Product Name	Package	Quantity per Reel	Pb Free	Halogen Free
RP507K001B-TR	DFN(PLP)1616-6D	5,000pcs	Yes	Yes
Output voltage (V_{SET}) is adjustable with external divider resistors. Recommended output voltage range is from 0.7V to 5.5V. RP507K001B has an auto-discharge function.				

Auto-discharge function quickly lowers the output voltage to 0V, when the chip enable signal is switched from the active mode to the standby mode, by releasing the electrical charge accumulated in the external capacitor.

PIN CONFIGURATIONS

• DFN(PLP)1616-6D

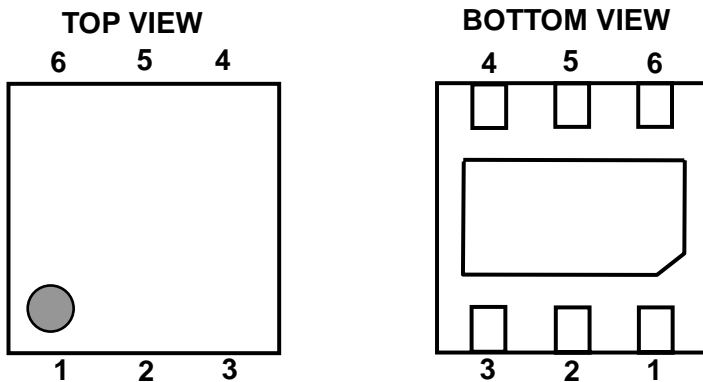

PIN DESCRIPTIONS

• RP507K: DFN(PLP)1616-6D

Pin No.	Symbol	Description
1	CE	Chip Enable Pin ("H" Active)
2	AGND	Ground Pin ^{*2}
3	PGND	Ground Pin ^{*2}
4	L _X	L _X Switching Pin
5	V _{IN}	Input Pin
6	V _{FB}	Feedback Pin

The exposed tab on the bottom of the package enhances thermal performance and is electrically connected to GND (substrate level). It is recommended that the exposed tab be connected to the ground plane on the board or otherwise be left open.

^{*2} No.2 pin and No.3 pin must be wired to the GND plane when mounting on boards.

ABSOLUTE MAXIMUM RATINGS

(AGND=PGND=0V)

Symbol	Item	Rating	Unit
V_{IN}	V_{IN} Input Voltage	-0.3 to 6.5	V
V_{LX}	L_X Pin Voltage	-0.3 to $V_{IN} + 0.3$	V
V_{CE}	CE Pin Input Voltage	-0.3 to 6.5	V
V_{FB}	V_{FB} Pin Voltage	-0.3 to 6.5	V
I_{LX}	L_X Pin Output Current	1	A
P_D	Power Dissipation (Standard Land Pattern) ^{*3}	640	mW
T_a	Operating Temperature Range	-40 to 85	°C
T_{stg}	Storage Temperature Range	-55 to 125	°C

^{*3} For Power Dissipation and Standard Land Pattern, please refer to PACKAGE INFORMATION.

ABSOLUTE MAXIMUM RATINGS

Electronic and mechanical stress momentarily exceeded absolute maximum ratings may cause the permanent damages and may degrade the life time and safety for both device and system using the device in the field. The functional operation at or over these absolute maximum ratings is not assured.

RECOMMENDED OPERATING CONDITIONS (ELECTRICAL CHARACTERISTICS)

All of electronic equipment should be designed that the mounted semiconductor devices operate within the recommended operating conditions. The semiconductor devices cannot operate normally over the recommended operating conditions, even if when they are used over such conditions by momentary electronic noise or surge. And the semiconductor devices may receive serious damage when they continue to operate over the recommended operating conditions.

ELECTRICAL CHARACTERISTICS

● RP507K001B

(Ta=25°C)

Symbol	Item	Conditions	Min.	Typ.	Max.	Unit
V _{IN}	Operating Input Voltage	1.0V ≤ V _{SET} ^{*6}	2.3		5.5	V
		0.9V ≤ V _{SET} < 1.0V	2.3		5.25	
		0.7V ≤ V _{SET} < 0.9V	2.3		4.5	
V _{FB}	Feedback Output Voltage	V _{IN} =V _{CE} =3.6V	0.591	0.600	0.609	V
ΔV _{FB} /ΔT	Feedback Output Voltage Temperature Coefficient	-40°C ≤ Ta ≤ 85°C		±100		ppm/°C
fosc	Oscillator Frequency	Refer to the conditions below. ^{*4}	1.7	2.0	2.3	MHz
I _{DD}	Supply Current	V _{IN} =V _{CE} =V _{FB} =3.6V		32	45	μA
I _{standby}	Standby Current	V _{IN} =5.5V, V _{CE} =0V		0	5	μA
I _{CEH}	CE "H" Input Current	V _{IN} =V _{CE} =5.5V	-1	0	1	μA
I _{CEL}	CE "L" Input Current	V _{IN} =5.5V, V _{CE} =0V	-1	0	1	μA
I _{VFBH}	VFB "H" Input Current	V _{IN} =V _{FB} =5.5V, V _{CE} =0V	-1	0	1	μA
I _{VFBL}	VFB "L" Input Current	V _{IN} =5.5V, V _{CE} =V _{FB} =0V	-1	0	1	μA
t _{dis}	Auto Discharge Time ^{*5}	V _{IN} =2.3V, V _{CE} =0V, C _{OUT} =10μF		5	10	ms
I _{LXLEAKH}	L _X Leakage Current "H"	V _{IN} =V _{LX} =5.5V, V _{CE} =0V	-1	0	5	μA
I _{LXLEAKL}	L _X Leakage Current "L"	V _{IN} =5.5V, V _{CE} =V _{LX} =0V	-5	0	1	μA
V _{CEH}	CE "H" Input Voltage	V _{IN} =5.5V	1.0			V
V _{CEL}	CE "L" Input Voltage	V _{IN} =2.3V			0.4	V
R _{ONP}	On Resistance of Pch Tr.	V _{IN} =3.6V, I _{LX} =-100mA		0.38		Ω
R _{ONN}	On Resistance of Nch Tr.	V _{IN} =3.6V, I _{LX} =-100mA		0.3		Ω
Maxduty	Maximum Duty Cycle		100			%
t _{start}	Soft-start Time	Refer to the conditions below. ^{*4}		150	300	μs
I _{LXLIM}	L _X Current Limit	Refer to the conditions below. ^{*4}	800	1000		mA
V _{UVLO1}	UVLO Detector Threshold	V _{IN} =V _{CE}	1.9	2.0	2.1	V
V _{UVLO2}	UVLO Released Voltage	V _{IN} =V _{CE}	2.0	2.1	2.2	V
T _{TSD}	Thermal Shutdown Temperature	Junction Temperature		140		°C
T _{TSR}	Thermal Shutdown Released Temperature	Junction Temperature		100		°C

Note: Test circuit is "OPEN LOOP" and AGND=PGND=0V unless otherwise specified.

^{*4} V_{IN}=V_{CE}=3.6V (V_{SET}≤2.6V), V_{IN}=V_{CE}=V_{SET}+1V (V_{SET}>2.6V)

^{*5} It starts when the CE pin is low and ends when V_{OUT} ≤ V_{SET} × 0.1.

^{*6} V_{SET}= Set Output Voltage

TYPICAL APPLICATION

(Adjustable Output Voltage Type)

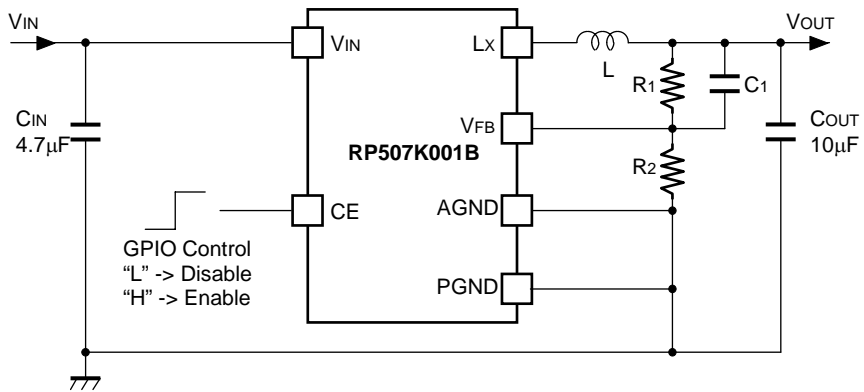
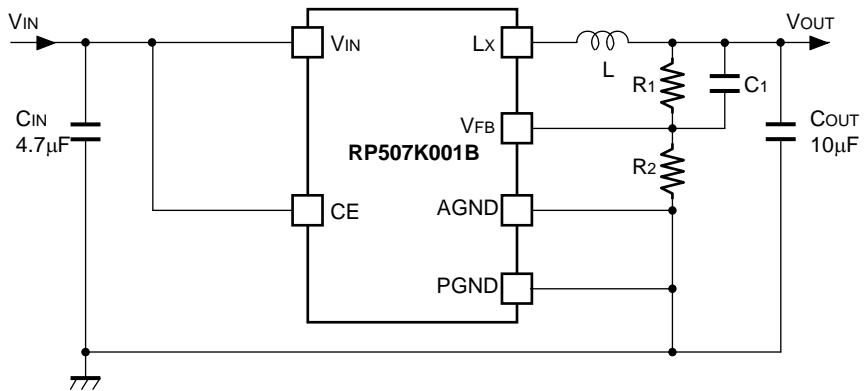
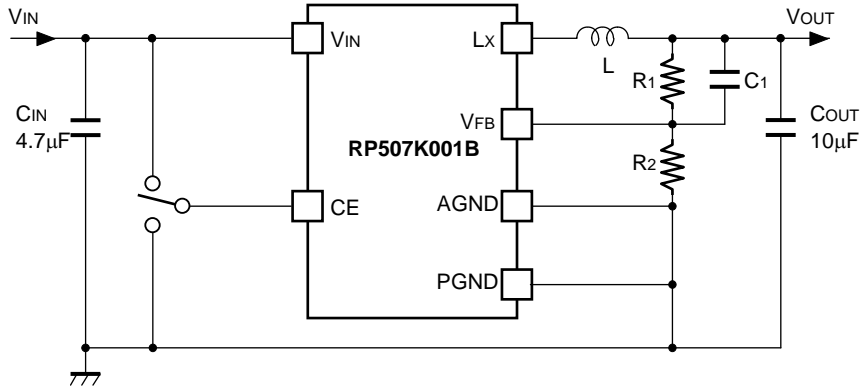

Table 1. Recommended Components

Symbol	Value	Components	Part Number
C _{IN}	4.7μF	Ceramic Capacitor	C1005X5R0J475M (TDK) JMK105BBJ475MV (Taiyo Yuden) GRM155R60J475ME47 (Murata)
C _{OUT}	10μF	Ceramic Capacitor	GRM155R60J106ME44 (Murata) JMK105CBJ106MV (Taiyo Yuden)
L	2.2μH	Inductor	LQM21PN2R2NGC (Murata) CIG21L2R2MNE (Samsung Electro-Mechanics) MIPSZ2012D2R2 (FDK)
	4.7μH		CIG21L4R7MNE (Samsung Electro-Mechanics) MIPS2520D4R7 (FDK)

TECHNICAL NOTES

When using the RP507K001B, please consider the following points.

- AGND and PGND must be wired to the GND plane when mounting on boards.
- Ensure the V_{IN} and AGND/ PGND lines are sufficiently robust. A large switching current flows through the AGND/ PGND lines, the V_{DD} line, the V_{OUT} line, an inductor, and L_X . If their impedance is too high, noise pickup or unstable operation may result. Set the external components as close as possible to the IC and minimize the wiring between the components and the IC, especially between a capacitor (C_{IN}) and the V_{IN} pin. The wiring between a resistor for setting output voltage (R_1) and an inductor (L) and between L and Load should be separated.
- Choose a low ESR ceramic capacitor. The capacitance of C_{IN} should be more than or equal to $4.7\mu\text{F}$. The capacitance of a capacitor (C_{OUT}) should be $10\mu\text{F}$.
- The Inductance value should be set within the range of $1.5\mu\text{H}$ to $4.7\mu\text{H}$. However, the inductance value is limited by output voltage, so please refer to the table below. The phase compensation of this IC is designed according to the C_{OUT} and L values. Choose an inductor that has small DC resistance, has enough allowable current and is hard to cause magnetic saturation. If the inductance value of an inductor is extremely small, the peak current of L_X may increase. The increased L_X peak current reaches "L_X limit current" to trigger over current protection circuit even if the load current is less than 600mA.

Table 2. Set Output Voltage Range vs. Inductance Range

Set Output Voltage (V) V_{SET}	Inductance		
	L=1.5 μH	L=2.2 μH	L=4.7 μH
0.7~1.0	Ok	Good	-
1.1~1.7	-	Good	-
1.8~2.5	-	Good	Ok
2.6~	-	Ok	Good

- Over current protection circuit may be affected by self-heating or power dissipation environment.
- The output voltage (V_{OUT}) is adjustable by changing the R_1 and R_2 values as follows.

$$V_{OUT} = V_{FB} \times (R_1 + R_2) / R_2 \quad (0.7\text{V} \leq V_{OUT} \leq 5.5\text{V})$$

- The recommended resistance values for R_1 , R_2 and C_1 are as follows.

Table 3. Set Output Voltage Range vs. Resistor & Capacitor Range

Set Output Voltage (V) V_{SET}	Resistor (k Ω)		Capacitor (pF)
	R_1	R_2	C_1
1.0	120	180	22
1.2	180	180	22
1.5	270	180	22
1.8	240	120	22
2.5	380	120	15
2.8	275	75	15
3.3	270	60	15

- ★ The performance of power source circuits using this IC largely depends on the peripheral circuits. When selecting the peripheral components, please consider the conditions of use. Do not allow each component, PCB pattern and the IC to exceed their respected rated values (voltage, current, and power) when designing the peripheral circuits.

OPERATION OF STEP-DOWN DC/ DC CONVERTER AND OUTPUT CURRENT

The step-down DC/ DC converter charges energy in the inductor when L_x Tr. turns "ON", and discharges the energy from the inductor when L_x Tr. turns "OFF" and operates with less energy loss, so that a lower output voltage (V_{OUT}) than the input voltage (V_{IN}) can be obtained.

The operation of the step-down DC/ DC converter is explained in the following figures.

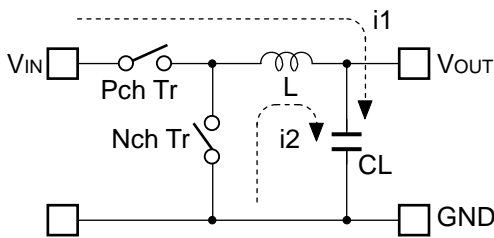

Figure 1. Basic Circuit

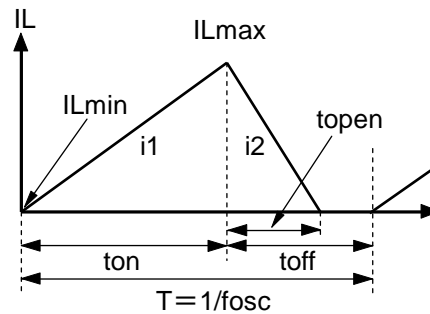

Figure 2. Inductor Current (I_L) flowing through Inductor

- Step1.** Pch Tr. turns "ON" and I_L (i_1) flows, L is charged with energy. At this moment, i_1 increases from the minimum inductor current (I_{Lmin}), which is 0A, and reaches the maximum inductor current (I_{Lmax}) in proportion to the on-time period (t_{on}) of Pch Tr.
- Step2.** When Pch Tr. turns "OFF", L tries to maintain I_L at I_{Lmax} , so L turns Nch Tr. "ON" and I_L (i_2) flows into L.
- Step3.** i_2 decreases gradually and reaches I_{Lmin} after the open-time period (t_{open}) of Nch Tr., and then Nch Tr. turns "OFF". This is called discontinuous current mode.
As the output current (I_{OUT}) increases, the off-time period (t_{off}) of Pch Tr. runs out before I_L reaches I_{Lmin} . The next cycle starts, and Pch Tr. turns "ON" and Nch Tr. turns "OFF", which means I_L starts increasing from I_{Lmin} . This is called continuous current mode.

In the case of PWM control system, V_{OUT} is maintained by controlling t_{on} . During PWM control, the oscillator frequency (f_{osc}) is being maintained constant.

As shown in Figure 2., when the step-down DC/ DC operation is constant, I_{Lmin} and I_{Lmax} during t_{on} of Pch Tr. would be same as during t_{off} of Pch Tr.

The current differential between I_{Lmax} and I_{Lmin} is described as ΔI .

$$\Delta I = I_{Lmax} - I_{Lmin} = V_{OUT} \times t_{open} / L = (V_{IN} - V_{OUT}) \times t_{on} / L \dots \dots \dots \text{Equation 1}$$

However,

$$T = 1 / f_{osc} = t_{on} + t_{off}$$

$$\text{Duty (\%)} = t_{on} / T \times 100 = t_{on} \times f_{osc} \times 100$$

$$t_{open} \leq t_{off}$$

In Equation 1, " $V_{OUT} \times t_{open} / L$ " shows the amount of current change in "OFF" state. Also, " $(V_{IN} - V_{OUT}) \times t_{on} / L$ " shows the amount of current change at "ON" state.

Discontinuous Mode and Continuous Mode

As illustrated in Figure 3., when I_{OUT} is relatively small, $t_{open} < t_{off}$. In this case, the energy charged into L during t_{on} will be completely discharged during t_{off} , as a result, $I_{Lmin} = 0$. This is called discontinuous mode.

When I_{OUT} is gradually increased, eventually $t_{open} = t_{off}$ and when I_{OUT} is increased further, eventually $I_{Lmin} > 0$. This is called continuous mode.

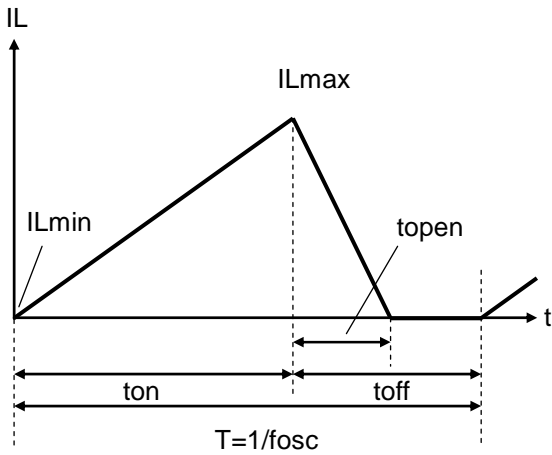

Figure 3. Discontinuous Mode

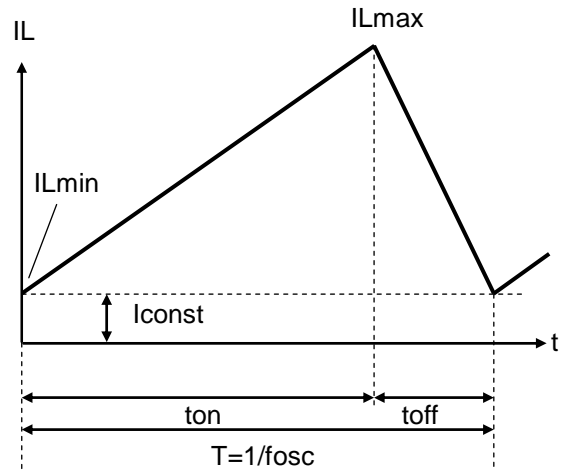

Figure 4. Continuous Mode

In the continuous mode, the solution of Equation 1 is described as t_{onc} .

$$t_{onc} = T \times V_{OUT} / V_{IN} \dots \dots \dots \text{Equation 2}$$

When $t_{on} < t_{onc}$, it is discontinuous mode, and when $t_{on} = t_{onc}$, it is continuous mode.

VFM Mode

In low output current, the IC automatically switches into VFM mode in order to achieve high efficiency. In VFM mode, t_{on} is forced to end when the inductor current reaches the pre-set I_{Lmax} . In the VFM mode, I_{Lmax} is typically set to 180mA. When t_{on} reaches 1.5 times of $T=1/f_{osc}$, t_{on} will be forced to end even if the inductor current is not reached I_{Lmax} .

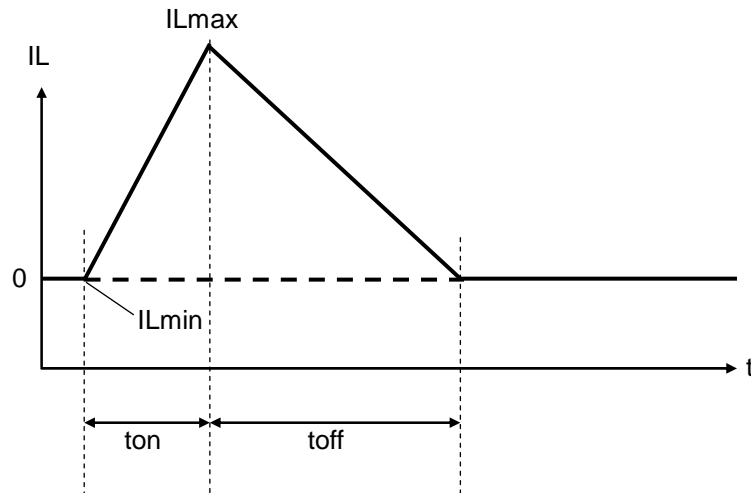

Figure 5. VFM Mode

OUTPUT CURRENT AND SELECTION OF EXTERNAL COMPONENTS

The following equations explain the relationship between output current and peripheral components used in the diagrams in "TYPICAL APPLICATIONS".

Ripple Current P-P value is described as I_{RP} , ON resistance of Pch Tr. is described as R_{ONP} , ON resistance of Nch Tr. is described as R_{ONN} , and DC resistor of the inductor is described as R_L .

First, when Pch Tr. is "ON", the following equation is satisfied.

$$V_{IN} = V_{OUT} + (R_{ONP} + R_L) \times I_{OUT} + L \times I_{RP} / t_{on} \dots\dots\dots \text{Equation 3}$$

Second, when Pch Tr. is "OFF" (Nch Tr. is "ON"), the following equation is satisfied.

$$L \times I_{RP} / t_{off} = R_{ONN} \times I_{OUT} + V_{OUT} + R_L \times I_{OUT} \dots\dots\dots \text{Equation 4}$$

Put Equation 4 into Equation 3 to solve ON duty of Pch Tr. ($D_{ON} = t_{on} / (t_{off} + t_{on})$):

$$D_{ON} = (V_{OUT} + R_{ONN} \times I_{OUT} + R_L \times I_{OUT}) / (V_{IN} + R_{ONN} \times I_{OUT} - R_{ONP} \times I_{OUT}) \dots\dots\dots \text{Equation 5}$$

Ripple Current is described as follows:

$$I_{RP} = (V_{IN} - V_{OUT} - R_{ONP} \times I_{OUT} - R_L \times I_{OUT}) \times D_{ON} / f_{osc} / L \dots\dots\dots \text{Equation 6}$$

Peak current that flows through L, and L_X Tr. is described as follows:

$$I_{L_{Xmax}} = I_{OUT} + I_{RP} / 2 \dots\dots\dots \text{Equation 7}$$

- ★ Please consider $I_{L_{XMAX}}$ when setting conditions of input and output, as well as selecting the external components.
- ★ The above calculation formulas are based on the ideal operation of the ICs in continuous mode.

TIMING CHART

(1) Soft-start Time

Starting-up with CE Pin

The IC starts to operate when the CE pin voltage (V_{CE}) exceeds the threshold voltage. The threshold voltage is preset between CE "H" input voltage (V_{CEH}) and CE "L" input voltage (V_{CEL}).

After the start-up of the IC, soft-start circuit starts to operate. Then, after a certain period of time, the reference voltage (V_{REF}) in the IC gradually increases up to the specified value.

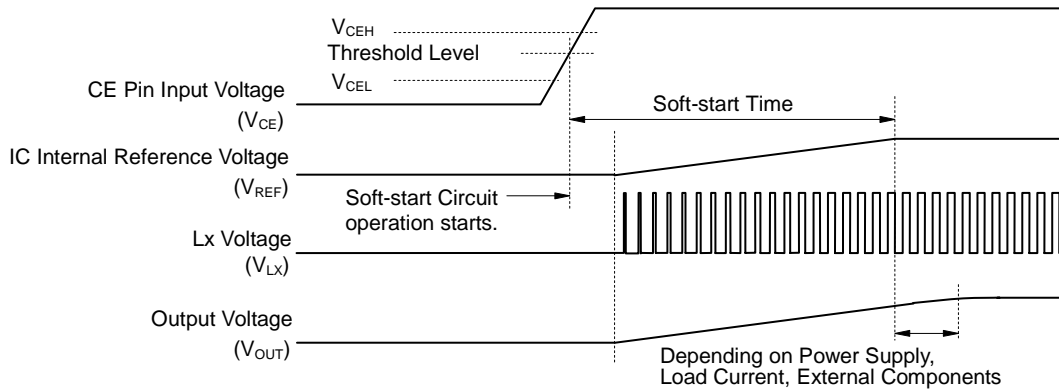

Soft-start time starts when soft-start circuit is activated, and ends when the reference voltage reaches the specified voltage.

- ★ Soft start time is not always equal to the turn-on speed of the step-down DC/ DC converter. Please note that the turn-on speed could be affected by the power supply capacity, the output current, the inductance value and the C_{OUT} value.

Starting-up with Power Supply

After the power-on, when V_{IN} exceeds the UVLO released voltage (V_{UVLO2}), the IC starts to operate. Then, soft-start circuit starts to operate and after a certain period of time, V_{REF} gradually increases up to the specified value. Soft-start time starts when soft-start circuit is activated, and ends when V_{REF} reaches the specified voltage.

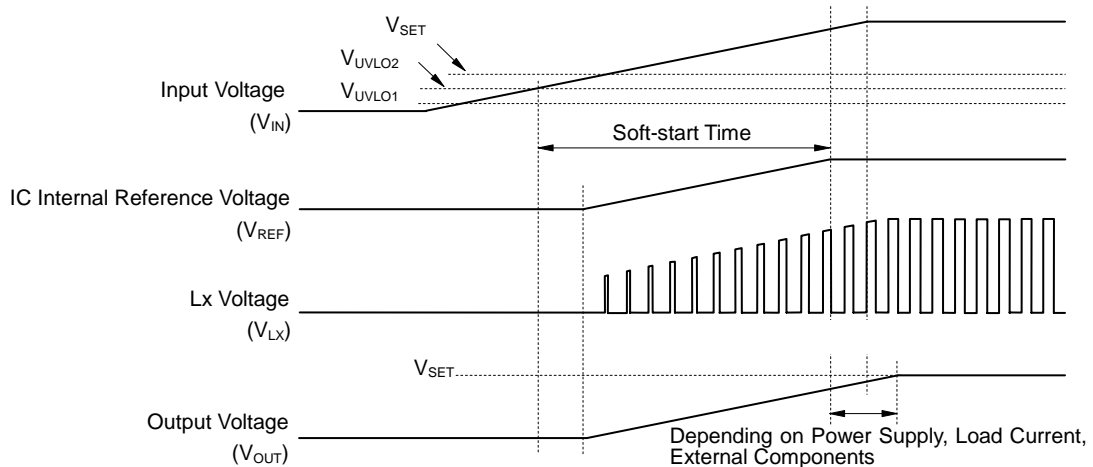

- ★ Please note that the turn-on speed of V_{OUT} could be affected by the power supply capacity, the output current, the inductance value, the C_{OUT} value and the turn-on speed of V_{IN} determined by C_{IN} .

(2) Under Voltage Lockout (UVLO) Circuit

If V_{IN} becomes lower than V_{SET} , the step-down DC/ DC converter stops the switching operation and ON duty becomes 100%, and then V_{OUT} gradually drops according to V_{IN} .

If the V_{IN} drops more and becomes lower than the UVLO detector threshold (V_{UVLO1}), the UVLO circuit starts to operate, V_{REF} stops, and Pch and Nch built-in switch transistors turn “OFF”. As a result, V_{OUT} drops according to the C_{OUT} capacitance value and the load.

To restart the operation, V_{IN} needs to be higher than V_{UVLO2} . The timing chart below shows the voltage shifts of V_{REF} , V_{LX} and V_{OUT} when V_{IN} value is varied.

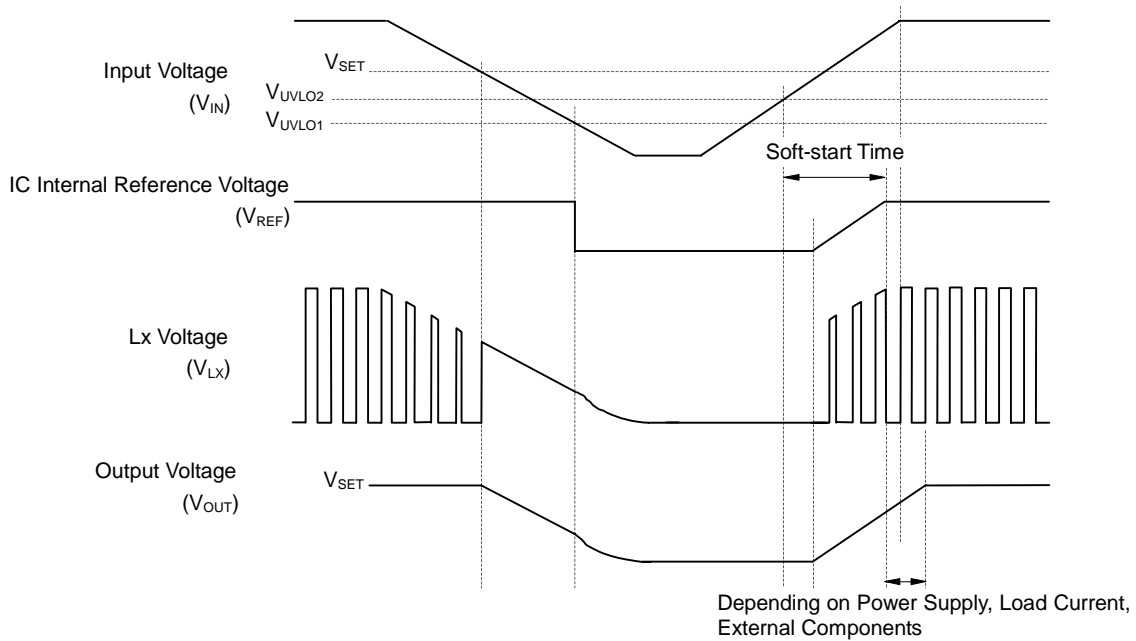

- ★ Falling edge (operating) and rising edge (releasing) waveforms of V_{OUT} could be affected by the initial voltage of C_{OUT} and the output current of V_{OUT} .

(3) Over Current Protection Circuit

Over current protection circuit supervises the inductor peak current (the peak current flowing through Pch Tr.) in each switching cycle, and if the current exceeds the L_x current limit (I_{LxLIM}), it turns off Pch Tr. I_{LxLIM} of the RP507K001B is set to Typ.1000mA.

Notes: I_{LxLIM} could be easily affected by self-heating or ambient environment. If the V_{IN} drops dramatically or becomes unstable due to short-circuit, protection operation could be affected.

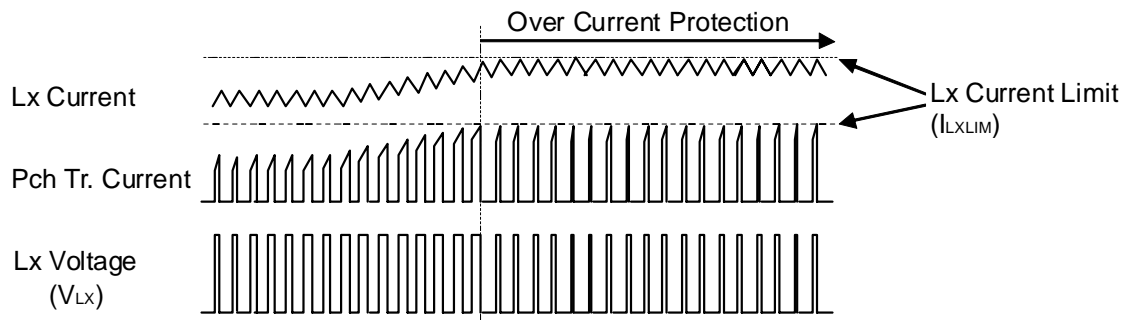

TYPICAL CHARACTERISTICS

1) Output Voltage vs. Output Current

RP507K001B $V_{OUT}=1.0V$

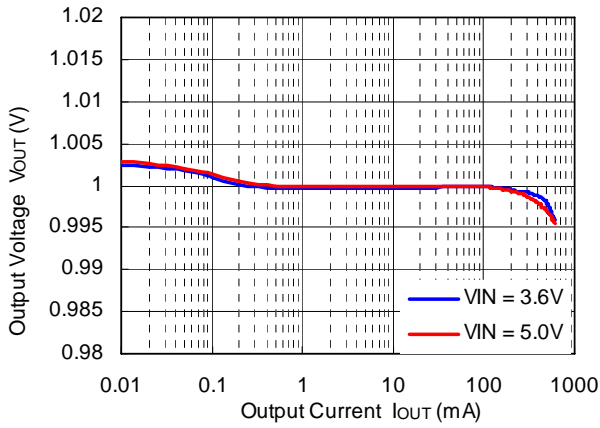

RP507K001B $V_{OUT}=1.2V$

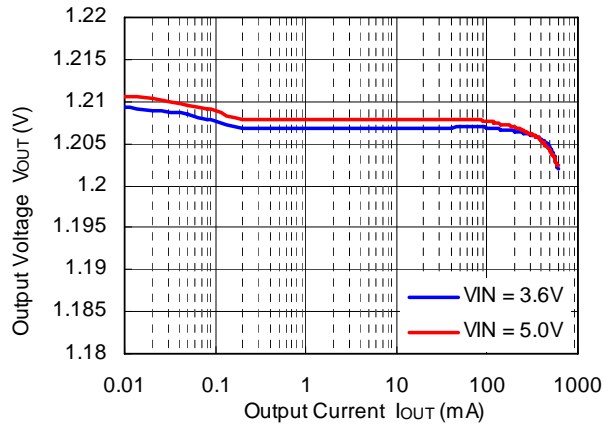

RP507K001B $V_{OUT}=1.8V$

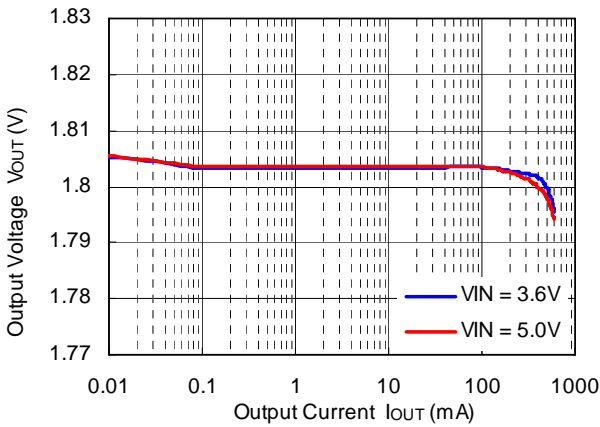

RP507K001B $V_{OUT}=3.3V$

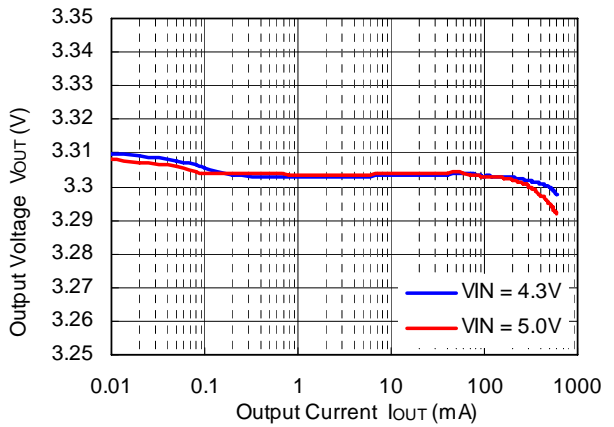

2) Output Voltage vs. Input Voltage

RP507K001B $V_{OUT}=1.0V$

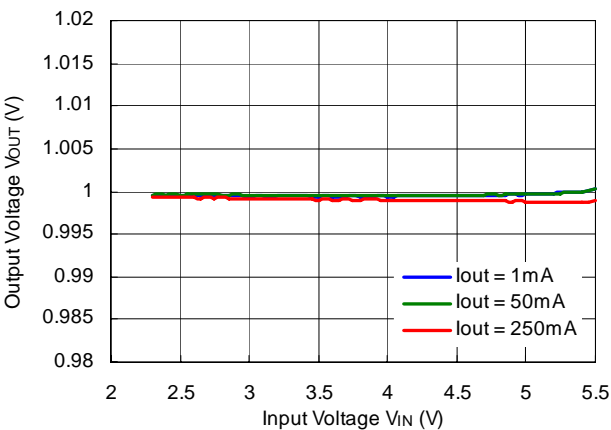

RP507K001B $V_{OUT}=1.2V$

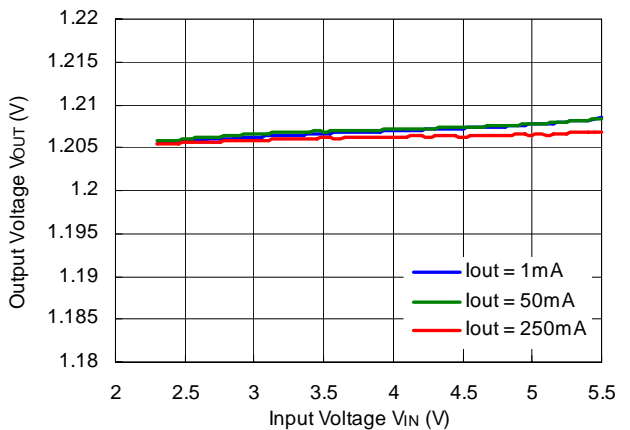

RP507K001B $V_{out}=1.8V$

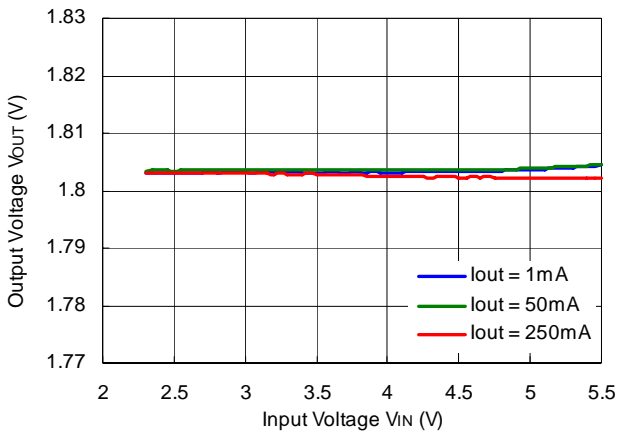

RP507K001B $V_{out}=3.3V$

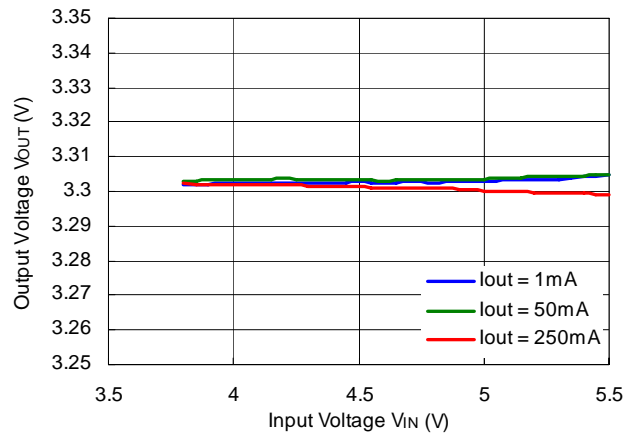

3) Feedback Voltage vs. Temperature

RP507K001B

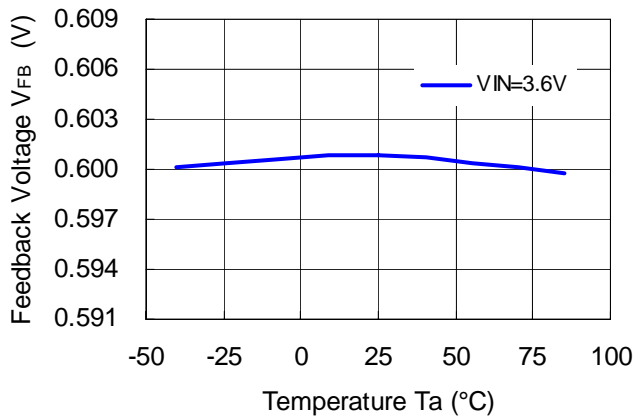

4) Efficiency vs. Output Current

RP507K001B $V_{out}=1.0V$
 $L=2.2\mu H$ (MIPSZ2012D2R2)

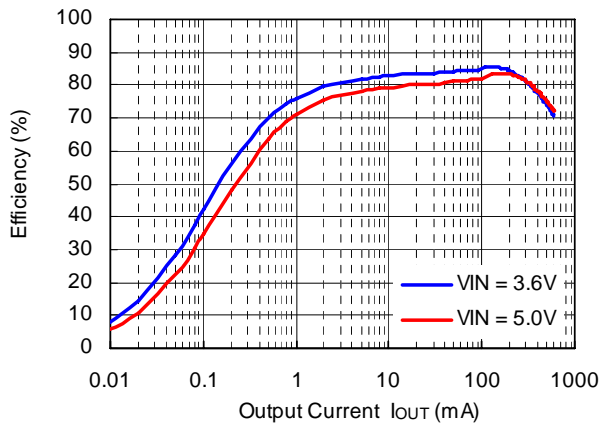

RP507K001B $V_{out}=1.2V$
 $L=2.2\mu H$ (MIPSZ2012D2R2)

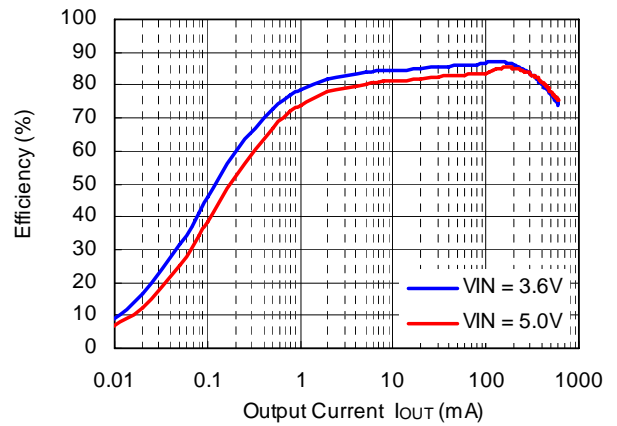

RP507K001B $V_{OUT}=1.8V$
 $L=2.2\mu H$ (MIPSZ2012D2R2)

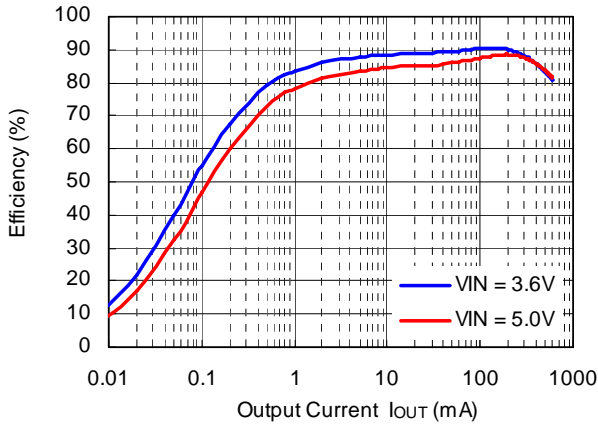

RP507K001B $V_{OUT}=3.3V$
 $L=4.7\mu H$ (MIPS2520D4R7)

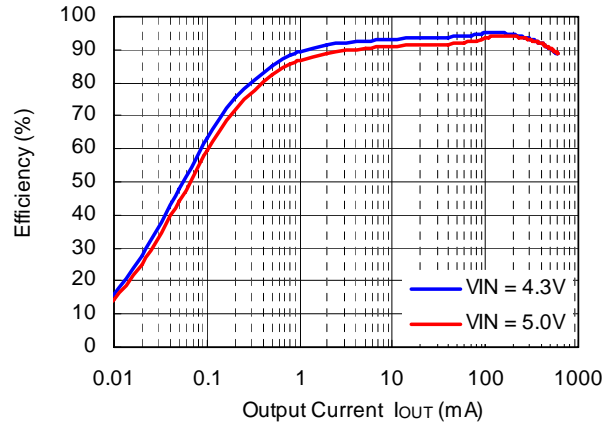

5) Supply Current vs. Temperature

RP507K001B $V_{OUT}=1.8V$ ($V_{IN}=3.6V$)

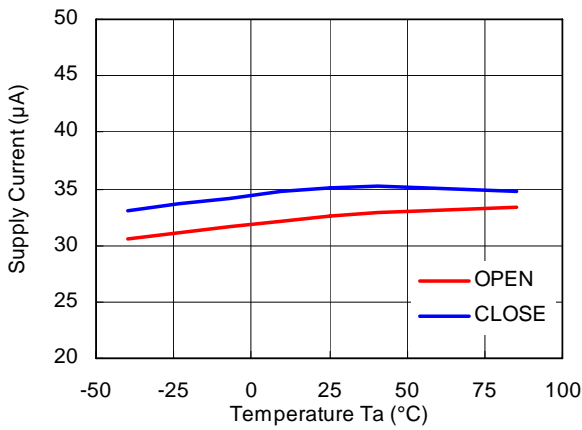

6) Supply Current vs. Input Voltage

RP507K001B $V_{OUT}=1.8V$

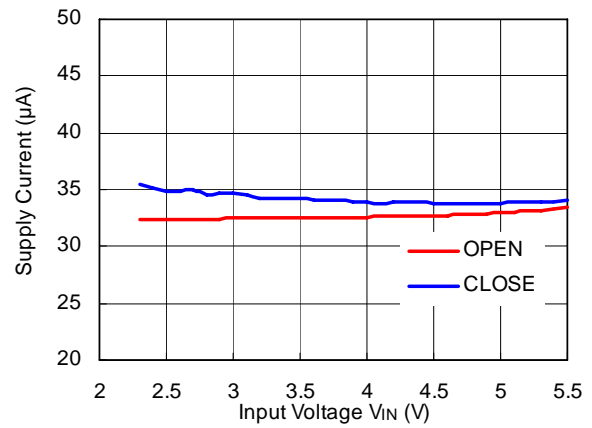

7) DC/DC Output Waveform

RP507K001B $V_{OUT}=1.0V$ ($V_{IN}=3.6V$)

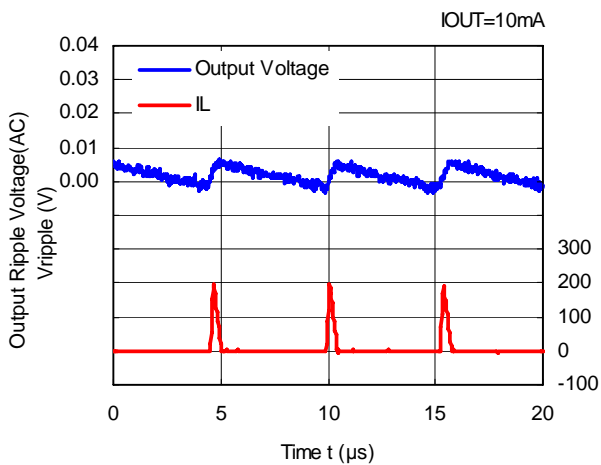

RP507K001B $V_{OUT}=1.0V$ ($V_{IN}=3.6V$)

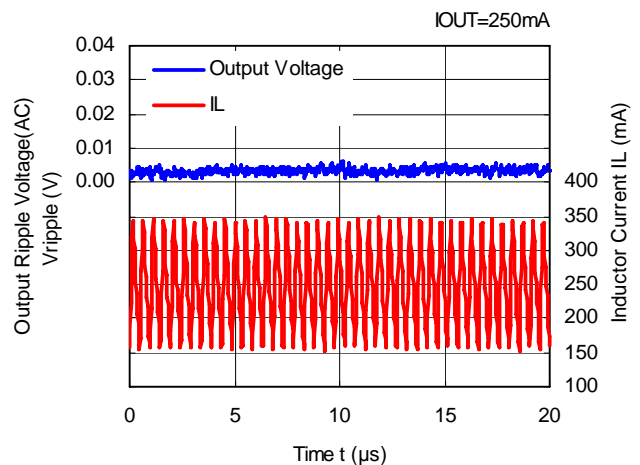

RP507K001B $V_{OUT}=1.2V$ ($V_{IN}=3.6V$)

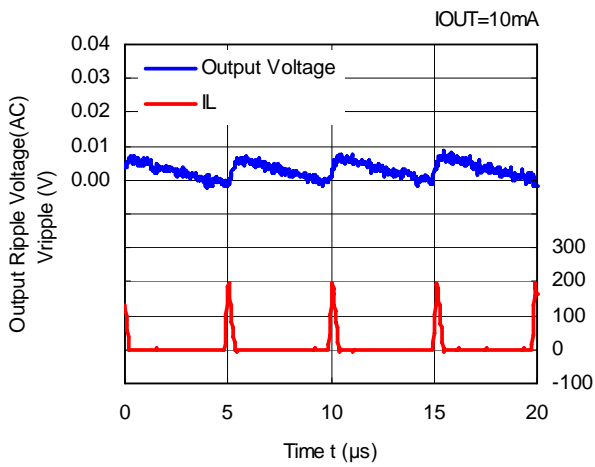

RP507K001B $V_{OUT}=1.2V$ ($V_{IN}=3.6V$)

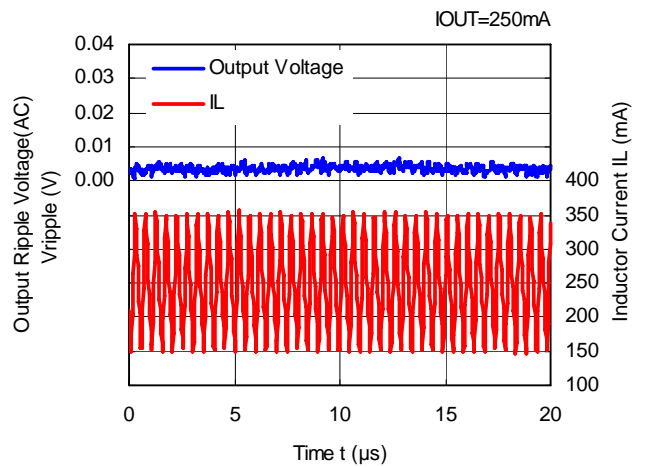

RP507K001B $V_{OUT}=1.8V$ ($V_{IN}=3.6V$)

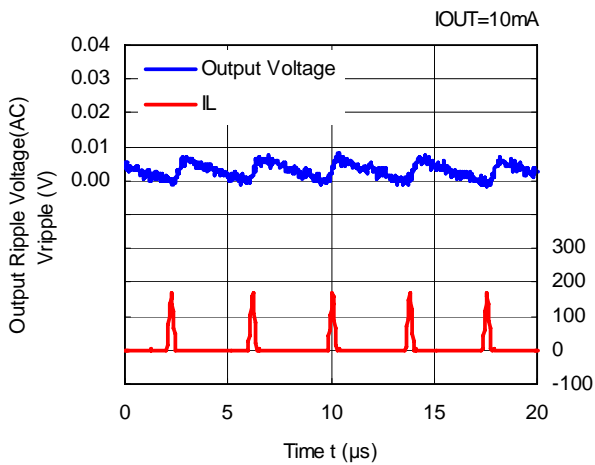

RP507K001B $V_{OUT}=1.8V$ ($V_{IN}=3.6V$)

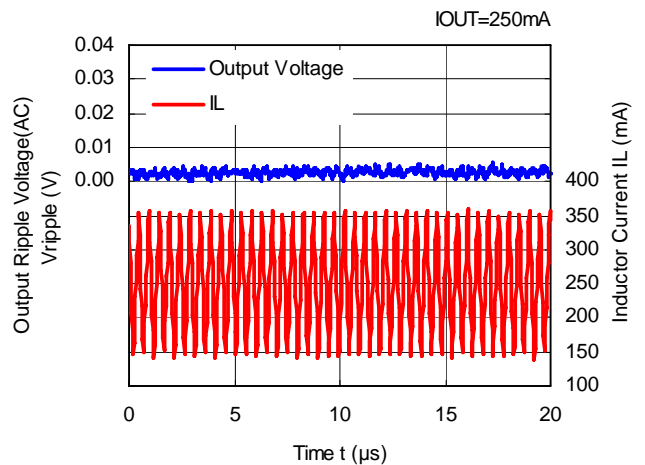

RP507K001B $V_{OUT}=3.3V$ ($V_{IN}=4.3V$)

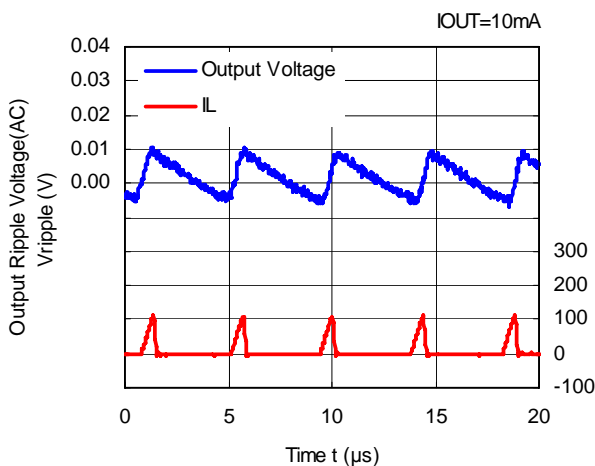

RP507K001B $V_{OUT}=3.3V$ ($V_{IN}=4.3V$)

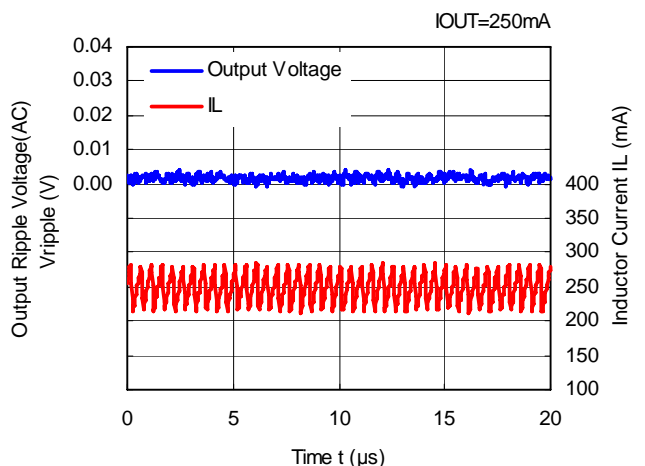

8) Oscillator Frequency vs. Temperature

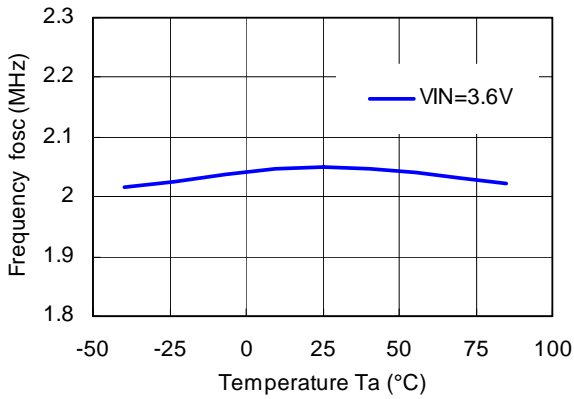

9) Oscillator Frequency vs. Input Voltage

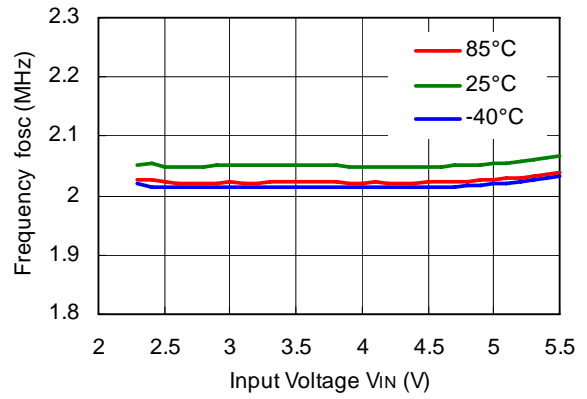

10) Soft-start Time vs. Temperature

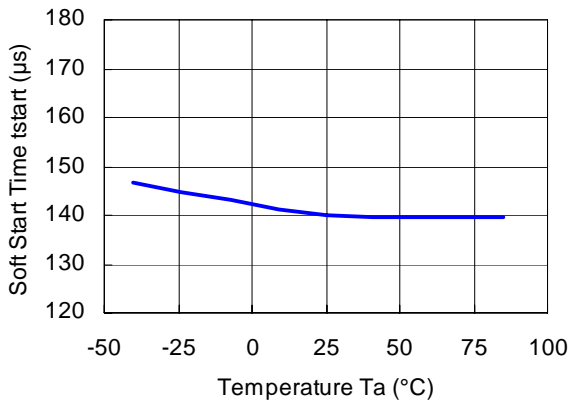

11) UVLO Detector Threshold / Released Voltage vs. Temperature

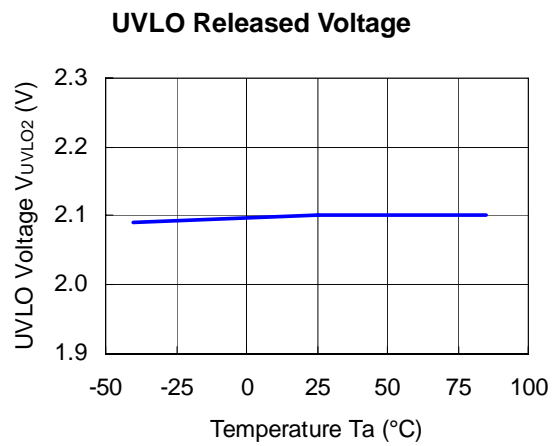
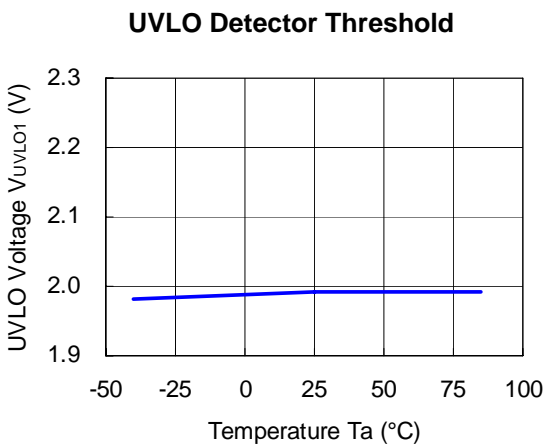

12) CE Input Voltage vs. Temperature

CE“H” Input Voltage ($V_{IN}=5.5V$)

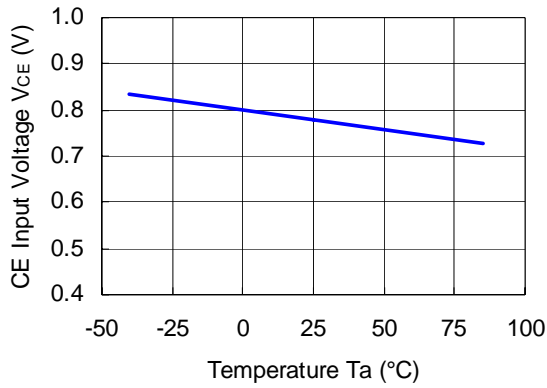

CE“L” Input Voltage ($V_{IN}=2.3V$)

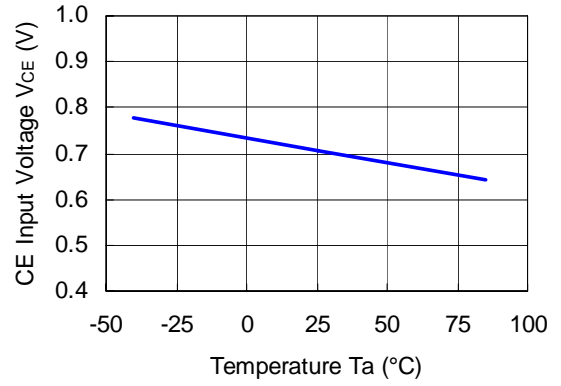

13) Lx Current Limit vs. Temperature

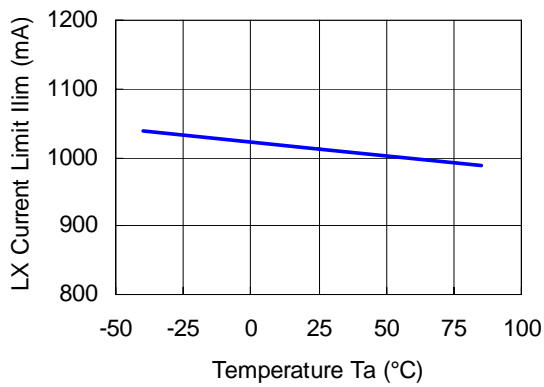

14) On Resistance of Pch Tr. vs. Temperature

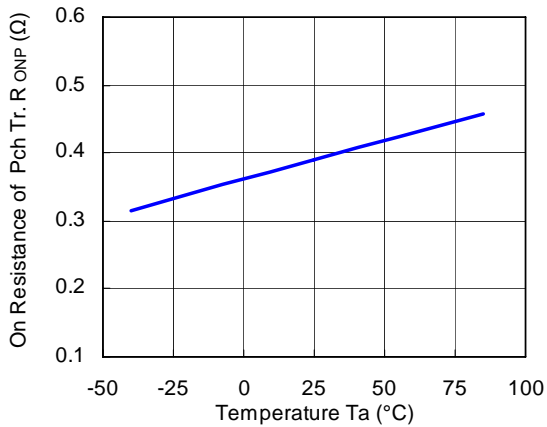

15) On Resistance of Nch Tr. vs. Temperature

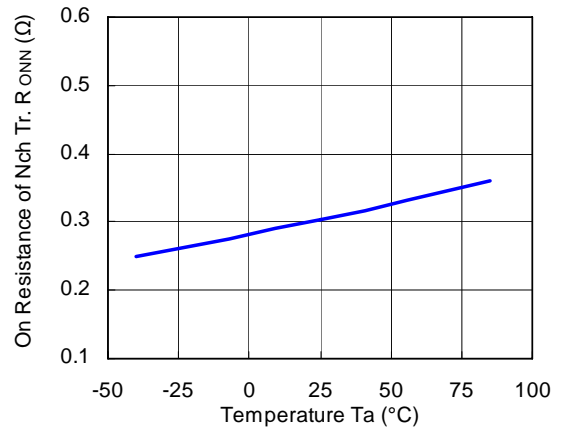

16) Load Transient Response ($C_{OUT}=10\mu F$ GRM155R60J106ME44)

RP507K001B ($V_{IN}=3.6V$, $V_{OUT}=1.0V$)

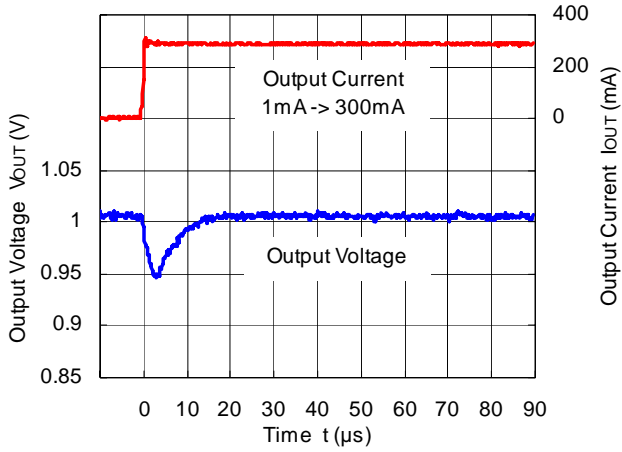

RP507K001B ($V_{IN}=3.6V$, $V_{OUT}=1.0V$)

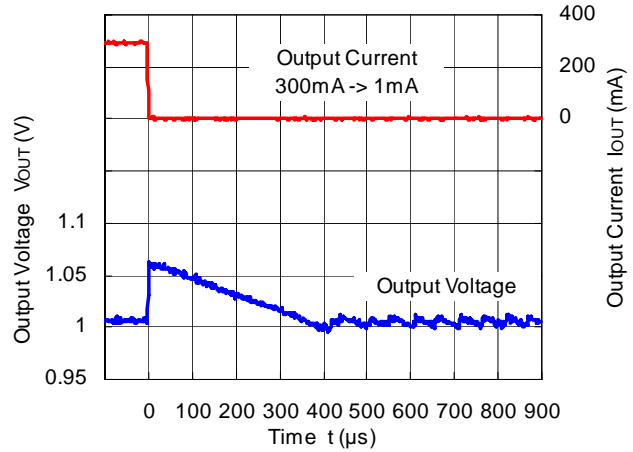

RP507K001B ($V_{IN}=3.6V$, $V_{OUT}=1.0V$)

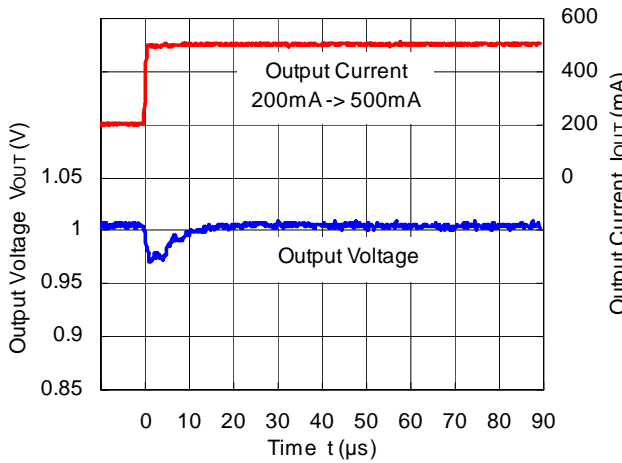

RP507K001B ($V_{IN}=3.6V$, $V_{OUT}=1.0V$)

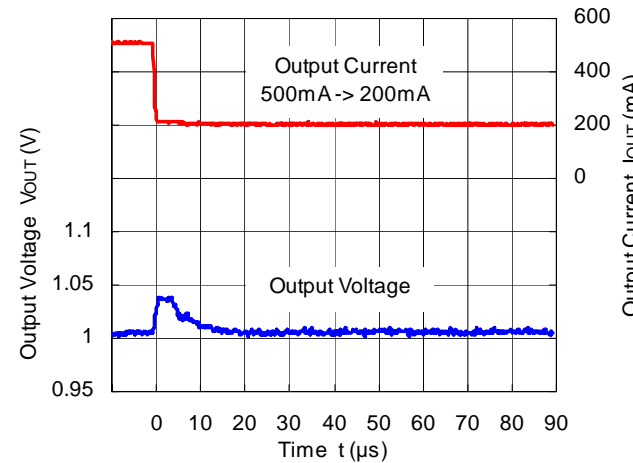

RP507K001B ($V_{IN}=3.6V$, $V_{OUT}=1.2V$)

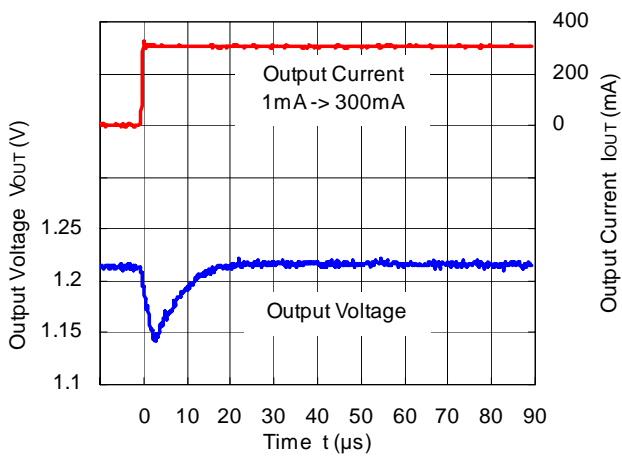

RP507K001B ($V_{IN}=3.6V$, $V_{OUT}=1.2V$)

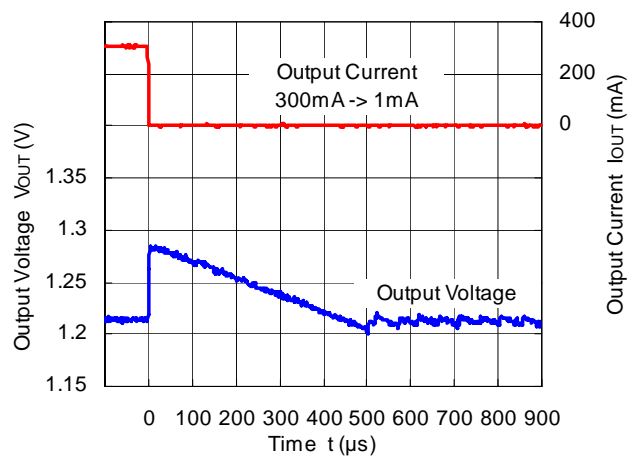

RP507K001B ($V_{IN}=3.6V$, $V_{OUT}=1.2V$)

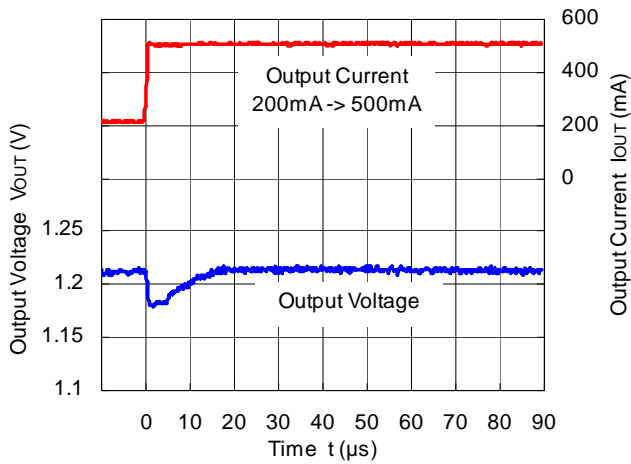

RP507K001B ($V_{IN}=3.6V$, $V_{OUT}=1.2V$)

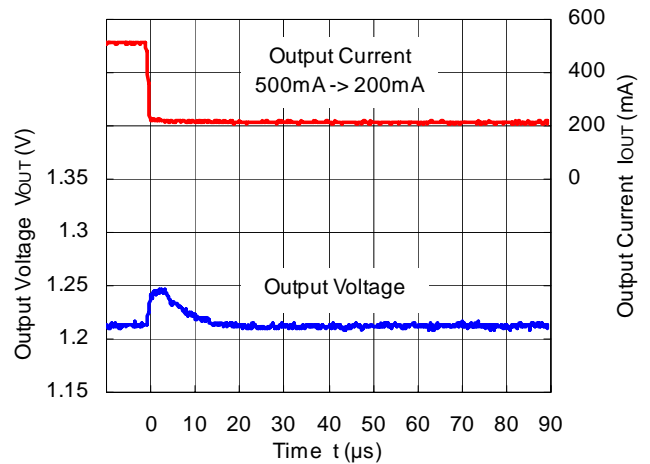

RP507K001B ($V_{IN}=3.6V$, $V_{OUT}=1.8V$)

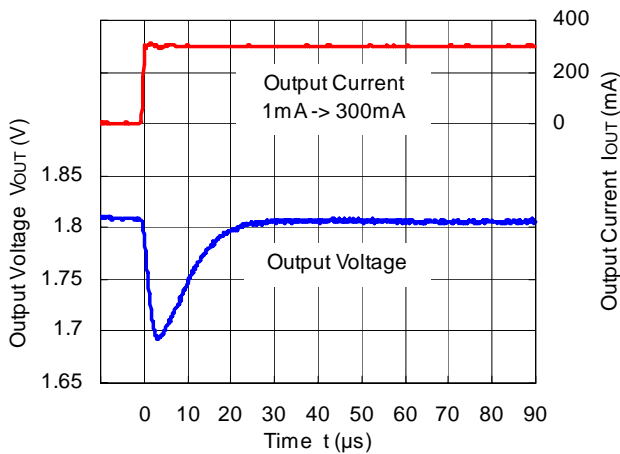

RP507K001B ($V_{IN}=3.6V$, $V_{OUT}=1.8V$)

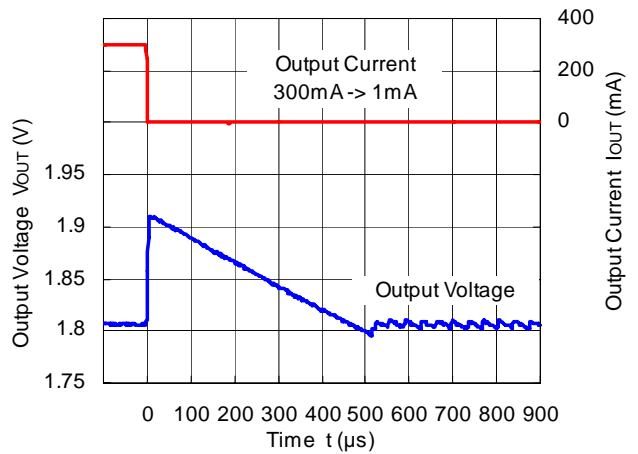

RP507K001B ($V_{IN}=3.6V$, $V_{OUT}=1.8V$)

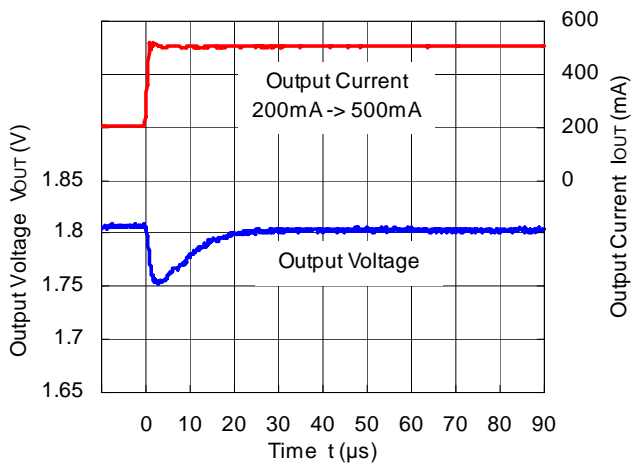

RP507K001B ($V_{IN}=3.6V$, $V_{OUT}=1.8V$)

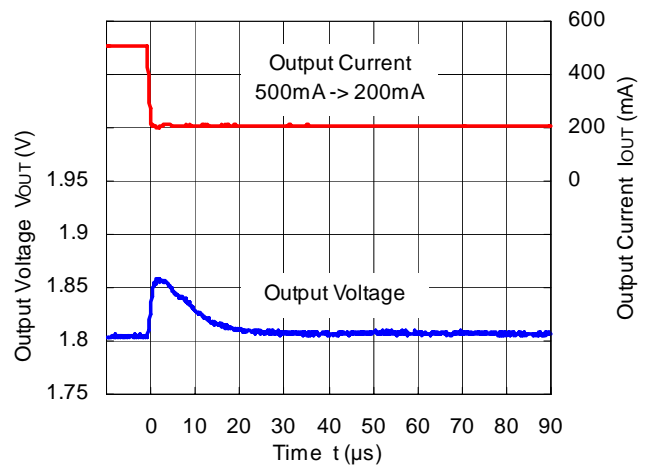

RP507K001B ($V_{IN}=5.0V$, $V_{OUT}=3.3V$)

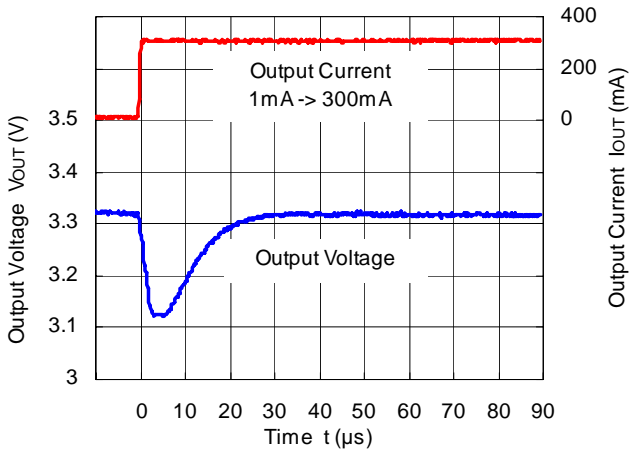

RP507K001B ($V_{IN}=5.0V$, $V_{OUT}=3.3V$)

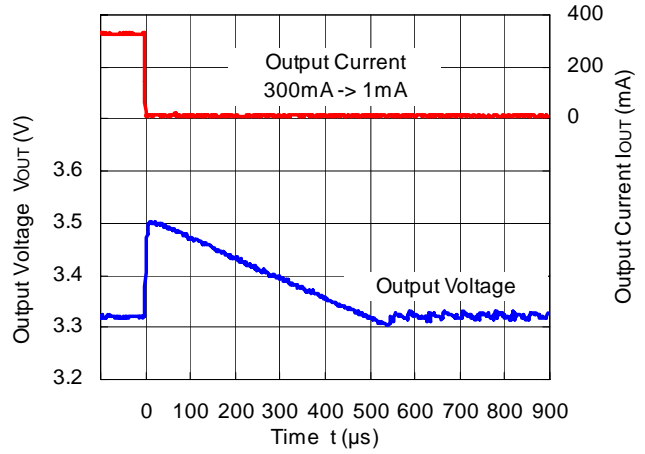

RP507K001B ($V_{IN}=5.0V$, $V_{OUT}=3.3V$)

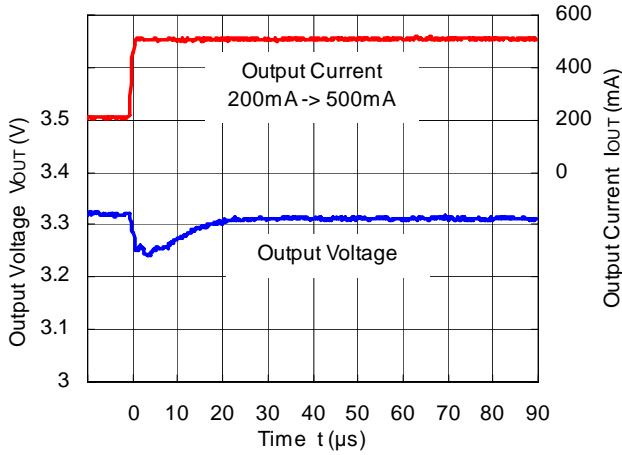

RP507K001B ($V_{IN}=5.0V$, $V_{OUT}=3.3V$)

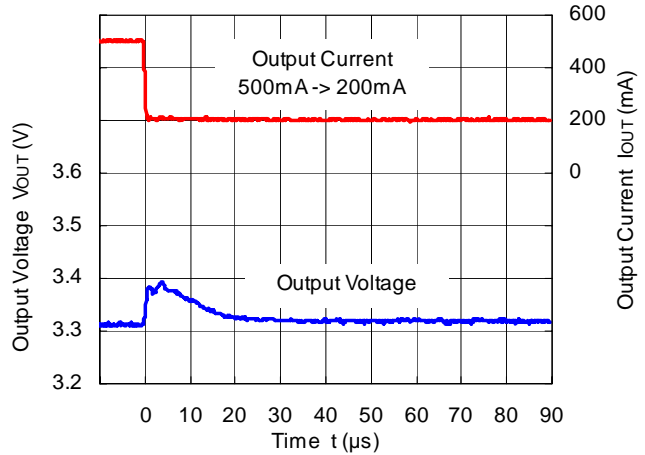



1. The products and the product specifications described in this document are subject to change or discontinuation of production without notice for reasons such as improvement. Therefore, before deciding to use the products, please refer to Ricoh sales representatives for the latest information thereon.
2. The materials in this document may not be copied or otherwise reproduced in whole or in part without prior written consent of Ricoh.
3. Please be sure to take any necessary formalities under relevant laws or regulations before exporting or otherwise taking out of your country the products or the technical information described herein.
4. The technical information described in this document shows typical characteristics of and example application circuits for the products. The release of such information is not to be construed as a warranty of or a grant of license under Ricoh's or any third party's intellectual property rights or any other rights.
5. The products listed in this document are intended and designed for use as general electronic components in standard applications (office equipment, telecommunication equipment, measuring instruments, consumer electronic products, amusement equipment etc.). Those customers intending to use a product in an application requiring extreme quality and reliability, for example, in a highly specific application where the failure or misoperation of the product could result in human injury or death (aircraft, spacevehicle, nuclear reactor control system, traffic control system, automotive and transportation equipment, combustion equipment, safety devices, life support system etc.) should first contact us.
6. We are making our continuous effort to improve the quality and reliability of our products, but semiconductor products are likely to fail with certain probability. In order to prevent any injury to persons or damages to property resulting from such failure, customers should be careful enough to incorporate safety measures in their design, such as redundancy feature, fire containment feature and fail-safe feature. We do not assume any liability or responsibility for any loss or damage arising from misuse or inappropriate use of the products.
7. Anti-radiation design is not implemented in the products described in this document.
8. Please contact Ricoh sales representatives should you have any questions or comments concerning the products or the technical information.



Ricoh is committed to reducing the environmental loading materials in electrical devices with a view to contributing to the protection of human health and the environment.

Ricoh has been providing RoHS compliant products since April 1, 2006 and Halogen-free products since April 1, 2012.

RICOH RICOH ELECTRONIC DEVICES CO., LTD.

<http://www.e-devices.ricoh.co.jp/en/>

Sales & Support Offices

RICOH ELECTRONIC DEVICES CO., LTD.

Higashi-Shinagawa Office (International Sales)
3-32-3, Higashi-Shinagawa, Shinagawa-ku, Tokyo 140-8655, Japan
Phone: +81-3-5479-2857 Fax: +81-3-5479-0502

RICOH EUROPE (NETHERLANDS) B.V.

Semiconductor Support Centre
Prof. W.H. Keesomlaan 1, 1183 DJ Amstelveen, The Netherlands
Phone: +31-20-5474-309

RICOH ELECTRONIC DEVICES KOREA CO., LTD.

3F, Haesung Bldg. 504, Teheran-ro, Gangnam-gu, Seoul, 135-725, Korea
Phone: +82-2-2135-5700 Fax: +82-2-2051-5713

RICOH ELECTRONIC DEVICES SHANGHAI CO., LTD.

Room 403, No.2 Building, No.690 Bilbo Road, Pu Dong New District, Shanghai 201203,
People's Republic of China
Phone: +86-21-5027-3200 Fax: +86-21-5027-3299

RICOH ELECTRONIC DEVICES CO., LTD.

Taipei office
Room 109, 10F-1, No.51, Hengyang Rd., Taipei City, Taiwan (R.O.C.)
Phone: +886-2-2313-1621/1622 Fax: +886-2-2313-1623

Mouser Electronics

Authorized Distributor

Click to View Pricing, Inventory, Delivery & Lifecycle Information:

[Ricoh Electronics:](#)

[RP507K001B-TR](#)



Компания «ЭлектроПласт» предлагает заключение долгосрочных отношений при поставках импортных электронных компонентов на взаимовыгодных условиях!

Наши преимущества:

- Оперативные поставки широкого спектра электронных компонентов отечественного и импортного производства напрямую от производителей и с крупнейших мировых складов;
- Поставка более 17-ти миллионов наименований электронных компонентов;
- Поставка сложных, дефицитных, либо снятых с производства позиций;
- Оперативные сроки поставки под заказ (от 5 рабочих дней);
- Экспресс доставка в любую точку России;
- Техническая поддержка проекта, помощь в подборе аналогов, поставка прототипов;
- Система менеджмента качества сертифицирована по Международному стандарту ISO 9001;
- Лицензия ФСБ на осуществление работ с использованием сведений, составляющих государственную тайну;
- Поставка специализированных компонентов (Xilinx, Altera, Analog Devices, Intersil, Interpoint, Microsemi, Aeroflex, Peregrine, Syfer, Eurofarad, Texas Instrument, Miteq, Cobham, E2V, MA-COM, Hittite, Mini-Circuits, General Dynamics и др.);

Помимо этого, одним из направлений компании «ЭлектроПласт» является направление «Источники питания». Мы предлагаем Вам помощь Конструкторского отдела:

- Подбор оптимального решения, техническое обоснование при выборе компонента;
- Подбор аналогов;
- Консультации по применению компонента;
- Поставка образцов и прототипов;
- Техническая поддержка проекта;
- Защита от снятия компонента с производства.



Как с нами связаться

Телефон: 8 (812) 309 58 32 (многоканальный)

Факс: 8 (812) 320-02-42

Электронная почта: org@eplast1.ru

Адрес: 198099, г. Санкт-Петербург, ул. Калинина, дом 2, корпус 4, литера А.