

## Electronic speed controller Discovery kit for drones with STM32G431CB

### Introduction

The B-G431B-ESC1 Discovery kit is mainly based on the STM32G431CB microcontroller, the L6387 driver and STL180N6F7 power MOSFETs. Its breakable form includes an electronic speed controller (ESC) board and a daughterboard for user interface with embedded ST-LINK/V2-1. The ESC has a very compacted size with the goal to drive a single 3-phase brushless motor (BLDC/PMSM), performing a sensorless field-oriented control (FOC) or 6-step control with speed regulation and active braking function. This unit can be connected with an external battery (LiPo type) and accepts a command signal from an external unit, for instance, a flight control board or similar. The system provides different communication buses (UART, CAN, PWM) for driving and monitoring, and also embeds an overcurrent and thermal protection circuit. The daughterboard contains an ST-LINK in-circuit debugger and programmer, allowing the user to program and debug the STM32G431CB microcontroller directly with a USB cable using a compatible toolset. Its form factor is suitable for small and very light R/C vehicles and their motor current capability, and also fits big vehicle requirements, for instance, a prosumer drone.

Figure 1. B-G431B-ESC1 Discovery kit  
(front view)

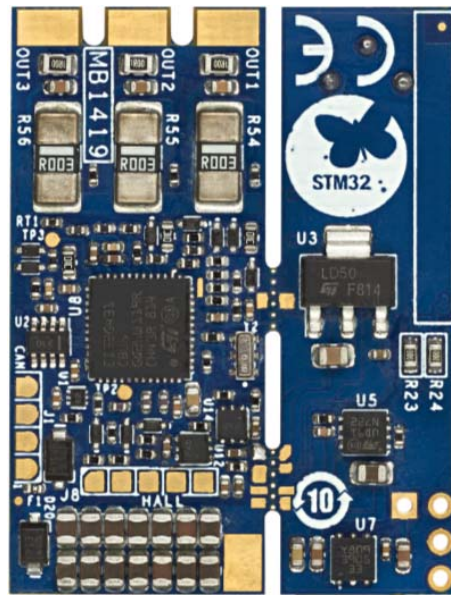
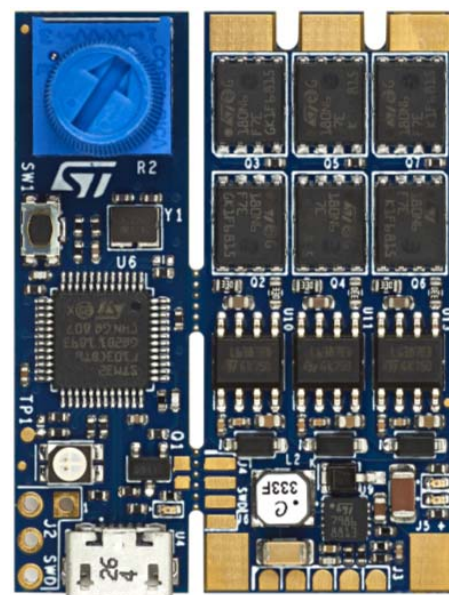

Figure 2. B-G431B-ESC1 Discovery kit  
(bottom view)



Pictures are not contractual.

# Contents

- 1        Features ..... 5**
- 2        Ordering information ..... 6**
  - 2.1    Product marking ..... 6
  - 2.2    Codification ..... 6
- 3        Development environment ..... 7**
  - 3.1    System requirements ..... 7
  - 3.2    Development toolchains ..... 7
  - 3.3    Software tool ..... 7
- 4        Description ..... 8**
- 5        Hardware layout and configuration ..... 10**
  - 5.1    Block diagram ..... 10
  - 5.2    Board dimensions ..... 12
  - 5.3    Communication, programming and command interfaces ..... 13
  - 5.4    Motor sensor connection (Hall or encoder) ..... 14
  - 5.5    CAN connection and configuration ..... 14
  - 5.6    STM32G431CB pinout for motor control ..... 15
- 6        Connection and first execution of the electronic speed controller (ESC) program ..... 18**
  - 6.1    First case: daughterboard not removed ..... 18
  - 6.2    Second case: daughterboard removed ..... 20
- 7        Schematic diagrams ..... 22**
- Revision history ..... 28**

## List of tables

Table 1.	Ordering information . . . . .	6
Table 2.	Codification explanation . . . . .	6
Table 3.	Truth table. . . . .	15
Table 4.	Main board STM32G431CB pinout for motor control . . . . .	15
Table 5.	Input/output terminal table . . . . .	17
Table 6.	SWD connector for MCU programming (daughterboard removed) . . . . .	20
Table 7.	Document revision history . . . . .	28

## List of figures

Figure 1.	B-G431B-ESC1 Discovery kit (front view) . . . . .	1
Figure 2.	B-G431B-ESC1 Discovery kit (bottom view). . . . .	1
Figure 3.	Target application . . . . .	5
Figure 4.	System structure overview . . . . .	9
Figure 5.	Block diagram with ST products . . . . .	10
Figure 6.	B-G431B-ESC1 top view . . . . .	10
Figure 7.	B-G431B-ESC1 bottom view . . . . .	11
Figure 8.	B-G431B-ESC1 board mechanical dimensions (top view) . . . . .	12
Figure 9.	Communication, programming and command interfaces . . . . .	13
Figure 10.	Motor sensor connection . . . . .	14
Figure 11.	ESC connections with CAN communication. . . . .	15
Figure 12.	B-G431B-ESC1 connection for MCU programming . . . . .	18
Figure 13.	ST MC Workbench screen . . . . .	19
Figure 14.	B-G431B-ESC1 I/O connection . . . . .	19
Figure 15.	PWM input signal for motor speed regulation. . . . .	20
Figure 16.	SWD configuration on IAR tool. . . . .	21
Figure 17.	CAN section . . . . .	23
Figure 18.	Daughterboard . . . . .	24
Figure 19.	MCU section . . . . .	25
Figure 20.	Power section . . . . .	26
Figure 21.	Sensing section . . . . .	27

# 1 Features

- Full reference design for electronic speed controller capable of both sensorless FOC and 6-step algorithm
- Designed for drones with up to 6S LiPo battery pack or equivalent suitable DC supply
- 3-phase driver board for BLDC/PMSM motors with discrete N-channel 60 V, 120 A STripFET F7 power MOSFETs
- Arm<sup>®(a)</sup> Cortex<sup>®</sup>-M4 32-bit STM32G431CB MCU, 213 DMIPS, 128 Kbytes of Flash memory, 32 Kbytes of SRAM, analog rich, math accelerator
- On-board ST-LINK/V2-1 debugger /programmer detachable from the main board
- Output peak motor current (maximum peak current tested with propeller to have an air-forced cooling): 40 A
- Designed with SMD ceramic capacitors with very low profile
- BEC available through the daughterboard (5 V for external board supplying, for example a flight control board)
- Support for motor sensors (Hall or encoder)
- Supported by ST motor control software development kit (SDK) with ST motor profiler
- 3-shunt mode supported for motor current sensing
- L6387 High voltage high and low-side driver with integrated interlocking function
- Overcurrent and overvoltage protection feature (OCP/OVP)
- Thermal measuring and overheating protection with NTC on board
- ESC ready for communication with any standard flight control unit (FCU): PWM/CAN/UART
- Potentiometer and user button available on daughter board
- 2 user LEDs: 1 green LED for 3.3 V level, and 1 red LED configurable by the user
- Target applications: motor driving for R/C vehicles, UAV drone, electric car or boat
- PCB type and size:
  - FR-4 PCB material
  - 8-layer layout
  - Dimensions (including the daughterboard with ST-LINK part): 30 mm x 41 mm
  - Weight (including the daughterboard with ST-LINK part): 9.2 g
- RoHS compliant

arm

Figure 3. Target application



a. Arm is a registered trademark of Arm Limited (or its subsidiaries) in the US and/or elsewhere.

## 2 Ordering information

To order the B-G431B-ESC1 Discovery kit, refer to [Table 1](#). Additional information is available from the datasheet and reference manual of the target STM32.

**Table 1. Ordering information**

Order code	Board reference	Target STM32
B-G431B-ESC1	MB1419	STM32G431C8U6

### 2.1 Product marking

Evaluation tools marked as “ES” or “E” are not yet qualified and are therefore not ready to be used as a reference design or in production. Any consequences arising from such usage will not be at STMicroelectronics’ charge. In no event will STMicroelectronics be liable for any customer usage of these engineering sample tools as reference designs or in production.

‘E’ or ‘ES’ marking examples of location:

- on the targeted STM32 that is soldered on the board (for illustration of STM32 marking, refer to the section *Package information* in the STM32 datasheet at [www.st.com](http://www.st.com)).
- next to the evaluation tool ordering part number, that is stuck or silkscreen printed on the board

### 2.2 Codification

The meaning of the codification of the Discovery kit is explained in [Table 2](#).

**Table 2. Codification explanation**

B-XXYYZ-ESCN	Description	Example: B-G431B-ESC1
XX	MCU series in STM32 32-bit Arm Cortex MCUs	STM32G4 Series
YY	MCU product line in the series	STM32G431
Z	STM32 Flash memory size: – B for 128 Kbytes	128 Kbytes
ESCN	Electronic speed controller version number	ESC1

## 3 Development environment

### 3.1 System requirements

- Windows® OS (7, 8 and 10), Linux® 64-bit, or macOS®(a)
- USB Type-A to Mini-B cable

### 3.2 Development toolchains

- Arm® Keil®: MDK-ARM<sup>(b)</sup>
- IAR™: EWARM<sup>(b)</sup>
- GCC-based IDEs

### 3.3 Software tool

This board is supported by the X-CUBE-MCSDK STM32Cube Expansion Package dedicated for motor-control applications. The source code is available and it is included and generated with this tool. The B-G431B-ESC1 does not have a demonstration firmware preloaded in the STM32 Flash memory, so for the first usage, the user must connect it with the X-CUBE-MCSDK tool.

---

a. macOS® is a trademark of Apple Inc. registered in the U.S. and other countries.  
b. On Windows® only.

## 4 Description

The B-G431B-ESC1 Discovery kit is an electronic speed controller (ESC) that drives a single 3-phase brushless motor with very high-performance control. It is commonly used inside the R/C field, for instance, drones, electric cars, and boats, with the goal to provide fast and efficient propulsion for the movement. This unit must be capable of low- and very high-speed regulation and strong dynamic response to different load conditions. An external signal, through a communication bus between the ESC board and a generic central unit, sets the reference value for the speed regulation, and another signal sends the status of the system. For instance, if a fault occurs, a central unit can decide to enable an emergency procedure.

In the mass market, a lot of ESCs are available to cover different kinds of R/C models, from the toy up to the professional unit, with different motor current capabilities, different sizes, and input voltage requirements. All of these boards are based on the same control algorithm, 6-step or trapezoidal, with no shunt resistors in a lot of cases.

B-G431B-ESC1 performs otherwise more sophisticated and smart control algorithm based on Field Oriented Control (FOC) comparing with the 6-step algorithm, in particular, it offers the following features:

- Better torque control
- Motor current regulation in case of a fast load change
- Vibration reduction
- Active braking function
- Better efficiency
- Noise reduction
- A real-time monitor of the rotor speed
- Energy recovery during the deceleration

The Discovery kit is also compatible with the 6-step control with embedded BEMF hardware circuit for rotor position estimation.



The typical system architecture is shown in *Figure 4*.

Each ESC board is connected with a single brushless motor, in this case, a quadcopter system is taken as an example. An external LiPo battery provides the right power to the four connected boards and through a wired bus, each ESC board receives or sends commands from or to an external unit, for instance, a flight control unit.

**Figure 4. System structure overview**

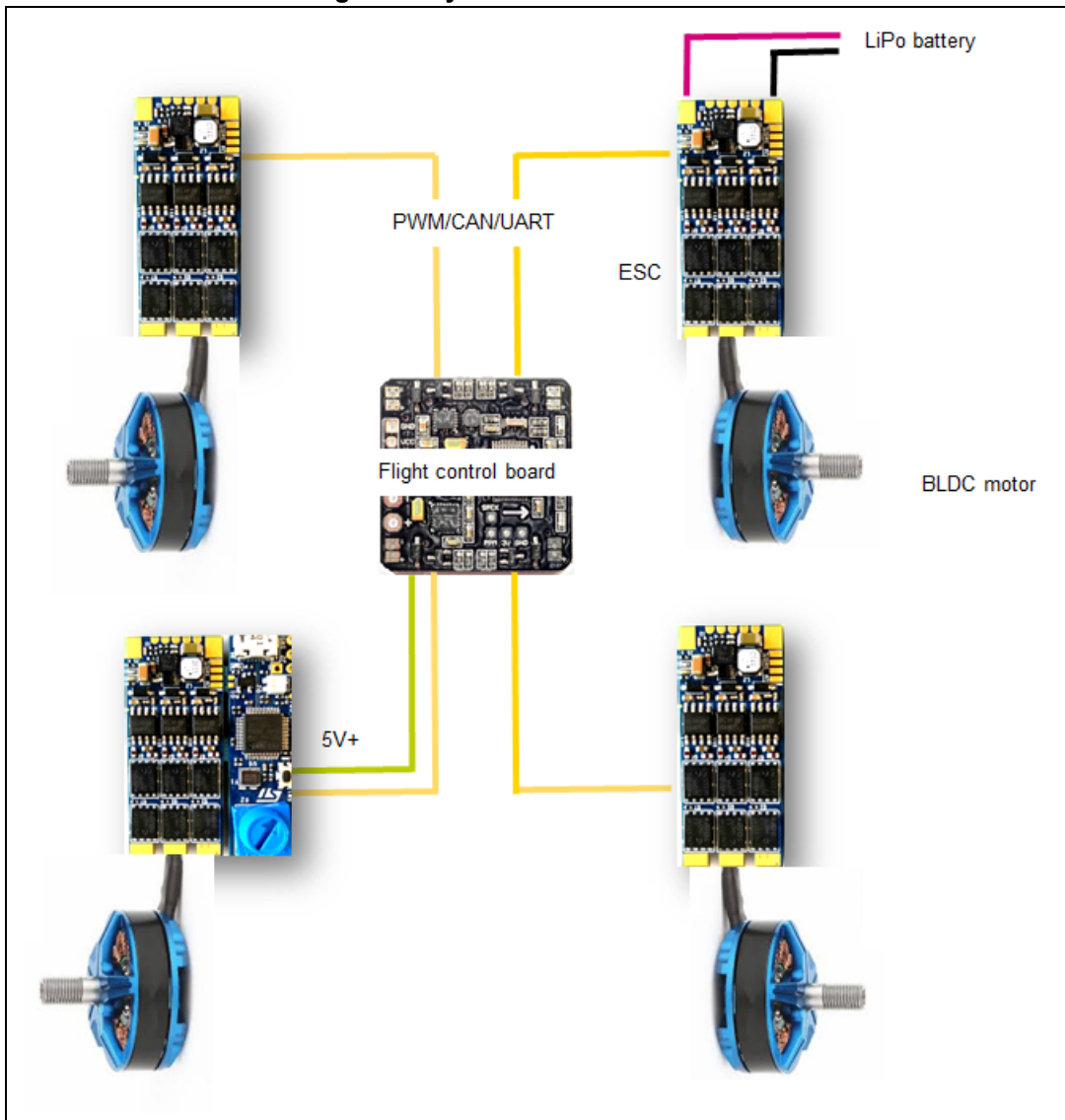

The B-G431B-ESC1 provides the maximum flexibility in term of communication protocol (UART, PWM and CAN are available on-board), and it also contains a DC-DC converter on the daughterboard, with 5 V output connector (BEC) to supply an external board, for instance, a flight control unit or sensors.

# 5 Hardware layout and configuration

## 5.1 Block diagram

The B-G431B-ESC1 Discovery kit is a complete hardware platform (power and control) based on several ST products as shown in the following block diagram:

Figure 5. Block diagram with ST products

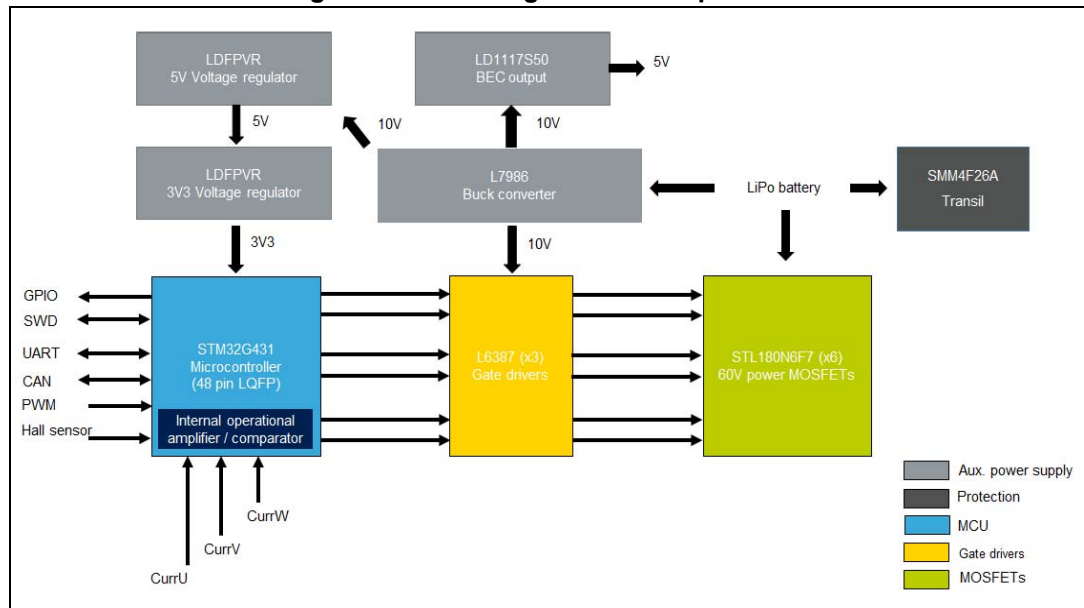

The top side is mainly dedicated to the power section. It is composed of power MOSFETs, gate drivers, and DC-DC converter.

Figure 6. B-G431B-ESC1 top view

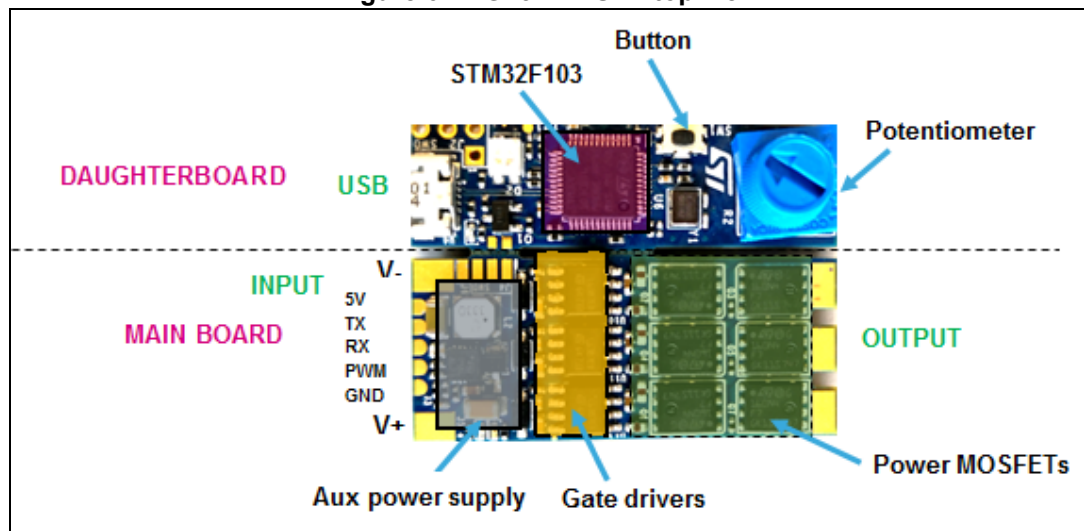

The bottom side is mainly dedicated to the digital section. It is composed of the STM32G431CB microcontroller that performs a three shunt both sensorless and sensed FOC control and 6-step control in an LQFP 48pin package.

The STM32G431CB devices are based on the high-performance Arm® Cortex®-M4 32-bit RISC core. They operate at a frequency of up to 170 MHz. The Cortex-M4 core features a single-precision floating-point unit (FPU), which supports all the Arm® single-precision data-processing instructions and all the data types. It also implements a full set of DSP (digital signal processing) instructions and a memory protection unit (MPU) which enhances the application's security.

The devices embed peripherals allowing mathematical/arithmetic function acceleration (CORDIC co-processor for trigonometric functions and FMAC unit for Filter Functions).

They offer two fast 12-bit ADCs (5 Msps), four comparators, three operational amplifiers, four DAC channels (2 external and 2 internal), an internal voltage reference buffer, a low-power RTC, one general-purpose 32-bit timers, two 16-bit PWM timers dedicated to motor control, seven general-purpose 16-bit timers, and one 16-bit low-power timer.

Figure 7. B-G431B-ESC1 bottom view

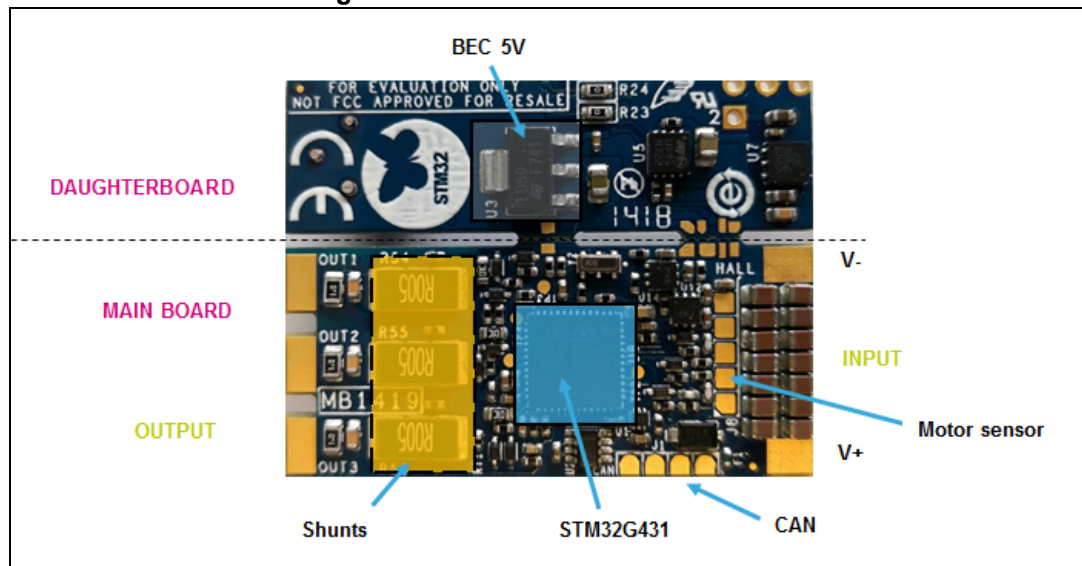

## 5.2 Board dimensions

The total dimension of the B-G431B-ESC1 Discovery kit (PCB) is 30 mm x 41 mm as shown in [Figure 8](#).

**Figure 8. B-G431B-ESC1 board mechanical dimensions (top view)**

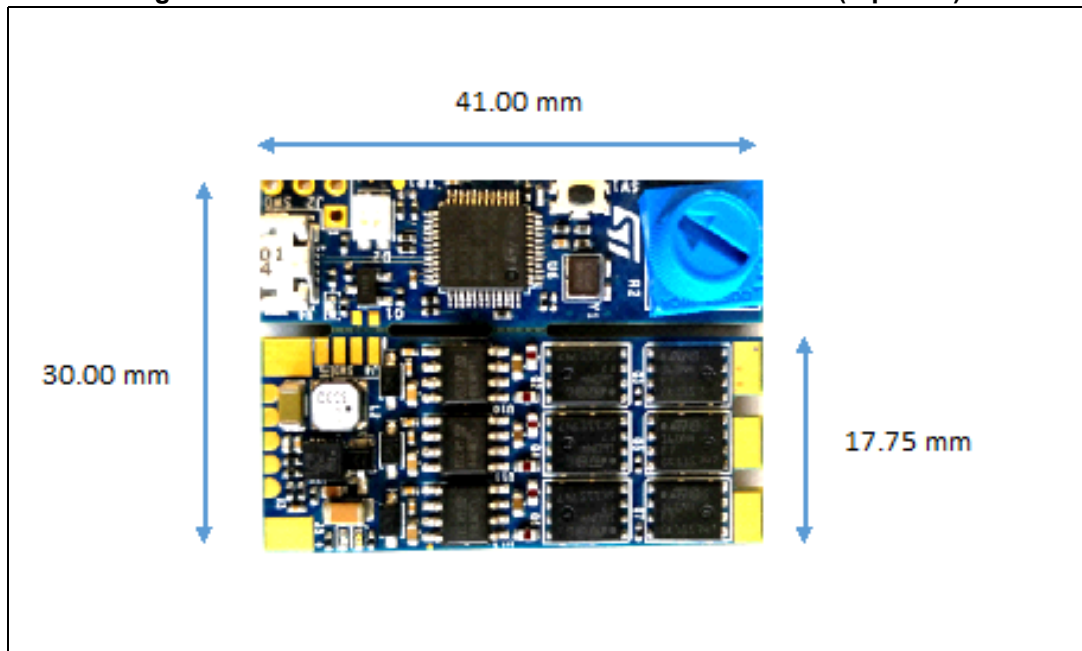

## 5.3 Communication, programming and command interfaces

The B-G431B-ESC1Discovery kit is equipped with a USB connector and different pads for communication, such as:

- U4 USB port for programming and debugging
- J1 for CAN port
- J2 for SWD-STM32F103 (reserved)
- J3 for PWM/UART/BECout input/output signal
- J4 for SWD-STM32G431 debug/programming port (without daughterboard)
- J8 for motor sensor (Hall or encoder)

**Figure 9. Communication, programming and command interfaces**

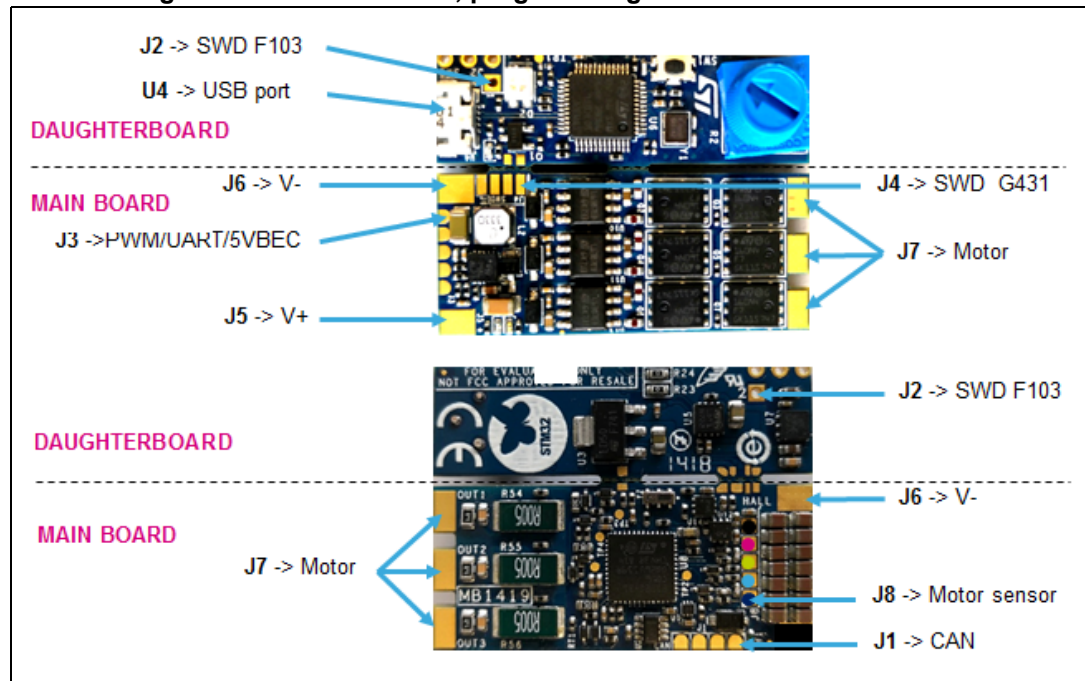

The USB interface is provided on the daughterboard and it allows to program and debug the main board. It provides also the supply voltage to the STM32G431CB MCU in case of no voltage on the bus (J5 and J6 not connected to the LiPo battery). The USB port is available to use the ST MC Workbench and Motor Profiler tool directly connected with the PC (no external dongle is needed).

The CAN interface is provided with an onboard transceiver and a termination resistor is provided and manageable by firmware. The J1 connector has also 5V and GND pins (see [Section 5.5](#) for further info)

The J2 is reserved to program the MCU on the daughterboard.

The J3 pads are available on the top side of the main board. They provide the UART TX and RX (for telemetry and firmware update respectively), the input PWM channel for motor speed regulation. In particular, the PWM input signal (5 V tolerant) sets the motor speed according to the Ton duration, for instance, 1060  $\mu$ s for the minimal speed and 1860  $\mu$ s for the maximum speed. Other pins are for GND and 5 V. It is a power line to supply an external board, for example, a flight control unit or equivalent. This voltage line is available only if the daughterboard is not removed.

The J4 solder pads provide the SWD connection between the STM32G431CB and the external ST-LINK programmer if the daughterboard is removed. In this case, other pins are available, such as 3V3 and GND.

The J8 solder pads allow the connection of the motor sensor, Hall or encoder. Refer to [Section 5.4](#) for further information.

### 5.4 Motor sensor connection (Hall or encoder)

The Discovery kit embeds the hardware circuit for Hall or encoder sensor. A supply voltage line is provided with 5 V and GND lines in J8 solder pads. This voltage is available also if the daughterboard is removed. The ST MC workbench must be configured to use these sensors during the FOC control.

Figure 10. Motor sensor connection



### 5.5 CAN connection and configuration

The main board includes the transceiver and the connection pads to use the CAN peripheral available in the STM32G431CB MCU. The hardware circuit is based on UAVCAN standard (<https://uavcan.org/>) so a little fuse is included to protect by overcurrent so that an accidental short circuit on the device does not bring down the power on the entire bus. One CAN output (J1) is provided on-board and T-connectors are needed to create the bus line with several boards.

This circuit accepts also the supply voltage from the external unit, for example, a flight control unit with a power CAN (5.0 V to 5.5 V on the bus power line). In this case, J1 solder pads contain the 5V line (input) and if a voltage is applied to it, the main board generates the 3.3 V for G4MCU and for the transceiver. This feature allows keeping the communication also when the battery is discharged or removed. [Figure 11](#) shows that two terminator resistors are needed to open and close the CAN bus line. B-G431B-ESC1 includes this terminator resistor (120 Ω) and it is manageable by firmware (CAN\_TERM pin) with a low voltage single-pole-double-throw analog onboard switch (see the CAN page on the electrical schematic). [Table 3](#) shows the logic to add or remove this resistor.

Figure 11. ESC connections with CAN communication

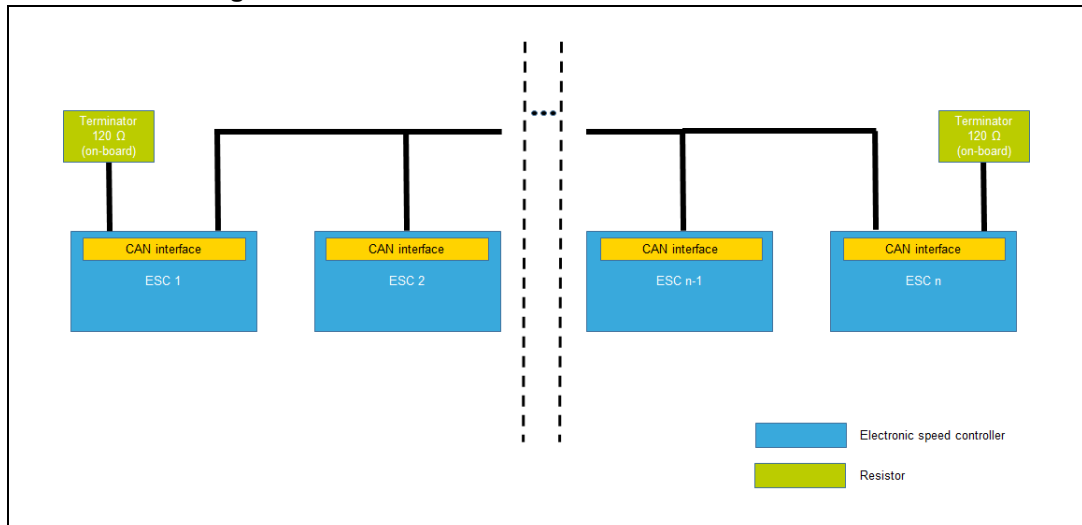

Table 3. Truth table

CAN_TERM pin	120 Ω resistor
H	ON
L	OFF <sup>(1)</sup>

1. High impedance

## 5.6 STM32G431CB pinout for motor control

Table 4. Main board STM32G431CB pinout for motor control

Pin	Default	Signal	Solder Bridge
1	VBAT	3V3	-
2	PC13/TAMP/RTC	TIM1_CH1N	-
3	PC14	CAN_TERM	R26
4	PC15	N.C.	-
5	PF0/OSC-IN	OSC 8Mhz	-
6	PF1/OSC-OUT	OSC 8Mhz	R27
7	PG10/NRST	RESET	-
8	PA0	VBUS	-
9	PA1	Curr_fdbk1_OPAm+	-
10	PA2	OP1_OUT	-
11	PA3	Curr_fdbk1_OPAm-	-
12	PA4	BEMF1	-
13	PA5	Curr_fdbk2_OPAm-	-
14	PA6	OP2_OUT	-

Table 4. Main board STM32G431CB pinout for motor control (continued)

Pin	Default	Signal	Solder Bridge
15	PA7	Curr_fdbk2_OPAmP+	-
16	PC4	BEMF2	-
17	PB0	Curr_fdbk3_OPAmP+	-
18	PB1	TP3	-
19	PB2	Curr_fdbk3_OPAmP-	-
20	VREF+	3v3	-
21	VDDA	3v3	-
22	PB10	N.C.	-
23	VDD4	3V3	-
24	PB11	BEMF3	-
25	PB12	POTENTIOMETER	-
26	PB13	N.C.	-
27	PB14	Temperature feedback	-
28	PB15	TIM1_CH3N	-
29	PC6	STATUS	-
30	PA8	TIM1_CH1	-
31	PA9	TIM1_CH2	-
32	PA10	TIM1_CH3	-
33	PA11	CAN_RX	-
34	PA12	TIM1_CH2N	-
35	VDD6	3V3	-
36	PA13	SWDIO	-
37	PA14	SWCLK	-
38	PA15	PWM	-
39	PC10	BUTTON	-
40	PC11	CAN_SHDN,TP2	-
41	PB3	USART2_TX	-
42	PB4	USART2_RX	-
43	PB5	GPIO_BEMF	-
44	PB6	A+/H1	-
45	PB7	B+/H2	-
46	PB8	Z+/H3	-
47	PB9	CAN_TX	-
48	VDD8	3V3	-



**Table 5. Input/output terminal table**

Main I/O Terminal	Function
J5/J6	LiPo battery power input (3S-6S)
J7	3-phase motor connector

## 6 Connection and first execution of the electronic speed controller (ESC) program

For the correct usage and the first run of the B-G431B-ESC1 Discovery kit, the procedure explained in [Section 6.1](#) or [Section 6.2](#) is suggested.

*The ESC board is usually powered with a battery (on J5 and J6 input connectors). It can be supplied with a laboratory power supply during software development. In this case, it is recommended to disconnect the power supply wires when the supply is switched-off while USB is connected (Some power supply types may cause board overheating in this case).*

### 6.1 First case: daughterboard not removed

1. Connect a micro USB cable to the USB port on the daughterboard as shown in [Figure 12](#), and verify if the green led (D5) is turned on in the main board.

Figure 12. B-G431B-ESC1 connection for MCU programming

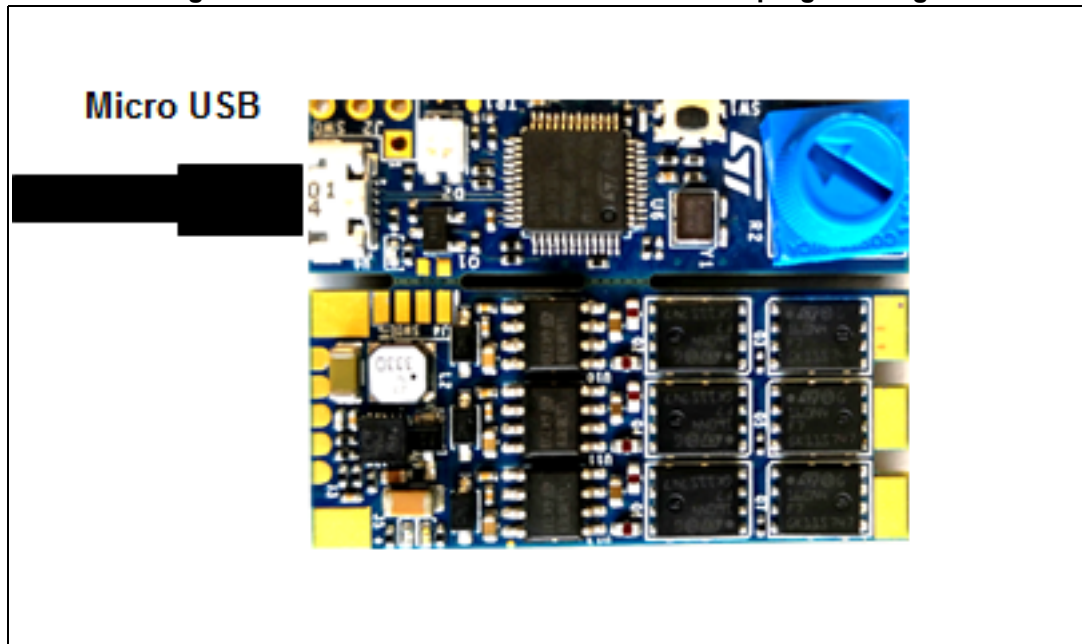

2. Connect the other part of the cable to the PC port and run the ST MC Workbench tool for motor and parameter configuration (see [Figure 13](#)).
3. Generate and upload the firmware code into the STM32G431CB MCU with the available IDE tool.

Figure 13. ST MC Workbench screen

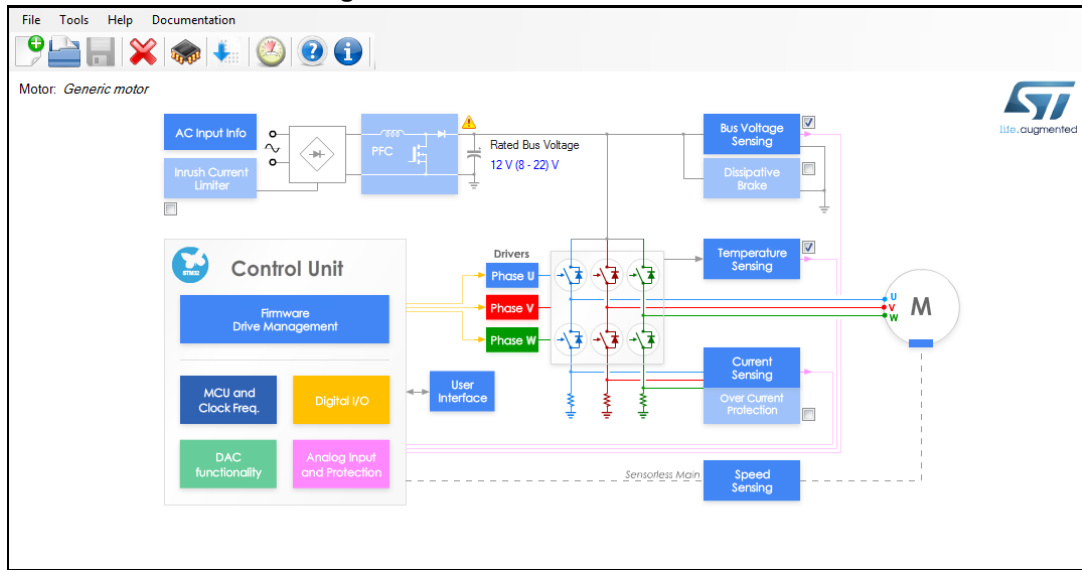

4. Solder the three motor wires U, V, W at the motor (J7) solder pad with no particular color sequence (see [Figure 14](#))
5. Solder the PWM input and GND at J3 connector (pin 4 and pin 5). The PWM input signal is either 3.3 V or 5 V (the PWM is connected to a 5 V tolerant MCU input pin).
6. Connect the main board with a LiPo battery (or DC power supply: min 3S - max 6S) with the right polarity and turn ON. The input connector is composed of two large pads for soldering. The Transil device prevents damage in case of reverse polarity at the input side for a low time.

Figure 14. B-G431B-ESC1 I/O connection

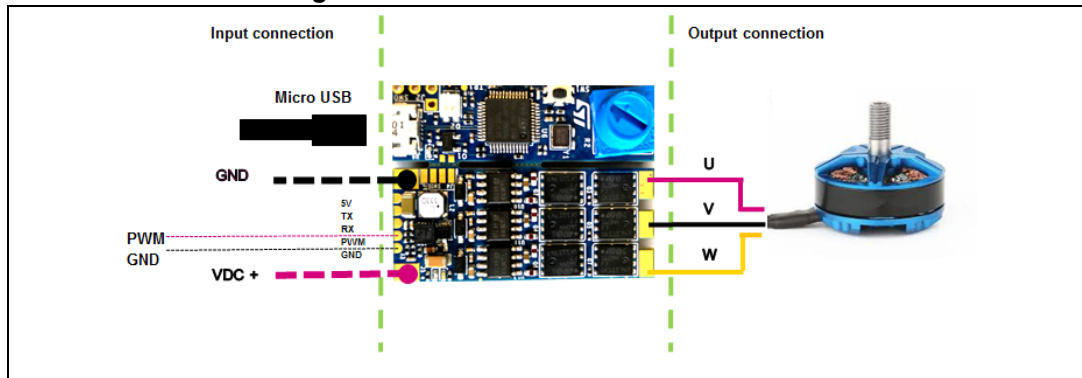

7. Generate on J3 connector a PWM signal at 490 Hz and duty cycle value between 1060  $\mu$ s and 1860  $\mu$ s, the motor starts to rotate respectively from the minimum to the maximum speed. The ESC is not armed (no driving signals generated) if the duty cycle is lower than 1060  $\mu$ s.

**Figure 15. PWM input signal for motor speed regulation**

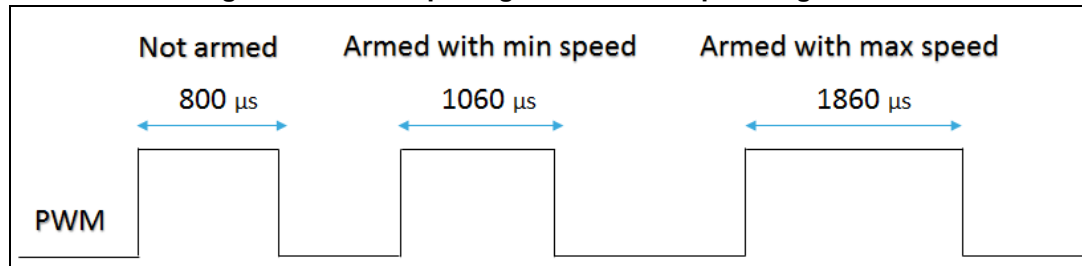

*Note:* In case the motor is already started, a blank time of 1500 ms on the PWM signal determines the switch off of the system (ESC turned OFF).

## 6.2 Second case: daughterboard removed

In case the daughterboard is removed, [Table 6](#) shows the relation between the SWD pinout on the main board and SWD on ST-LINK/V2 (not isolated version) external programmer.

**Table 6. SWD connector for MCU programming (daughterboard removed)**

Pin no. in STLINK	ST-LINK/V2 connector	ST-LINK/V2 function	Target connection (SWD)	Pin no. in DK B-G431B-ESC1 (J4 pad)
1	VAPP	Target VCC	MCU VDD	3
2	VAPP	Target VCC	MCU VDD	3
6	GND	-	GND	4
7	-	SW IO	SWDIO	1
9	-	SW CLK	SWCLK	2

Set the SWD interface inside the IDE tool, for instance, a picture of IAR Workbench is shown in [Figure 16](#).

If the daughterboard is removed the following pad connections are available on it:

- On the top side -> SWDIO, SWCLK
- On the bottom side -> NRST, +10V,+5V, 5V\_ESC, GND

Figure 16. SWD configuration on IAR tool

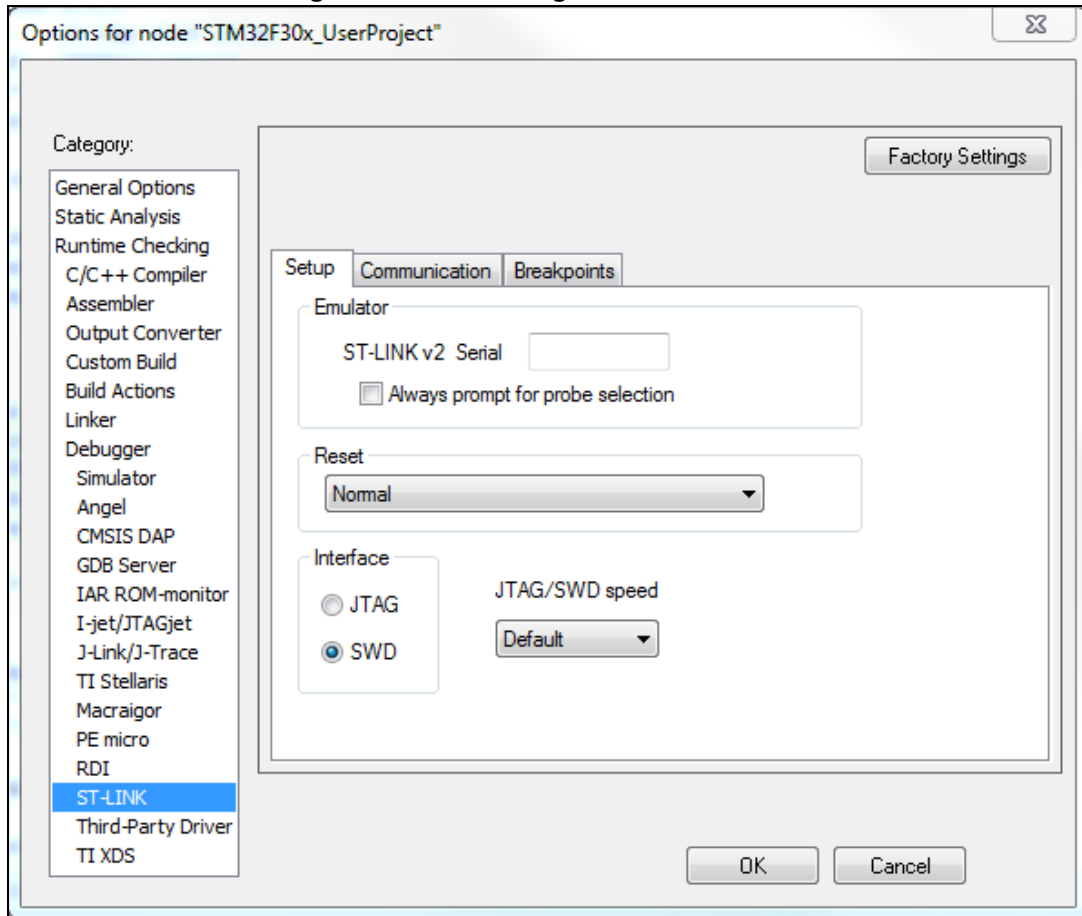

## 7 Schematic diagrams

- [Figure 17: CAN section on page 23](#)
- [Figure 18: Daughterboard on page 24](#)
- [Figure 19: MCU section on page 25](#)
- [Figure 20: Power section on page 26](#)
- [Figure 21: Sensing section on page 27](#)

Figure 17. CAN section

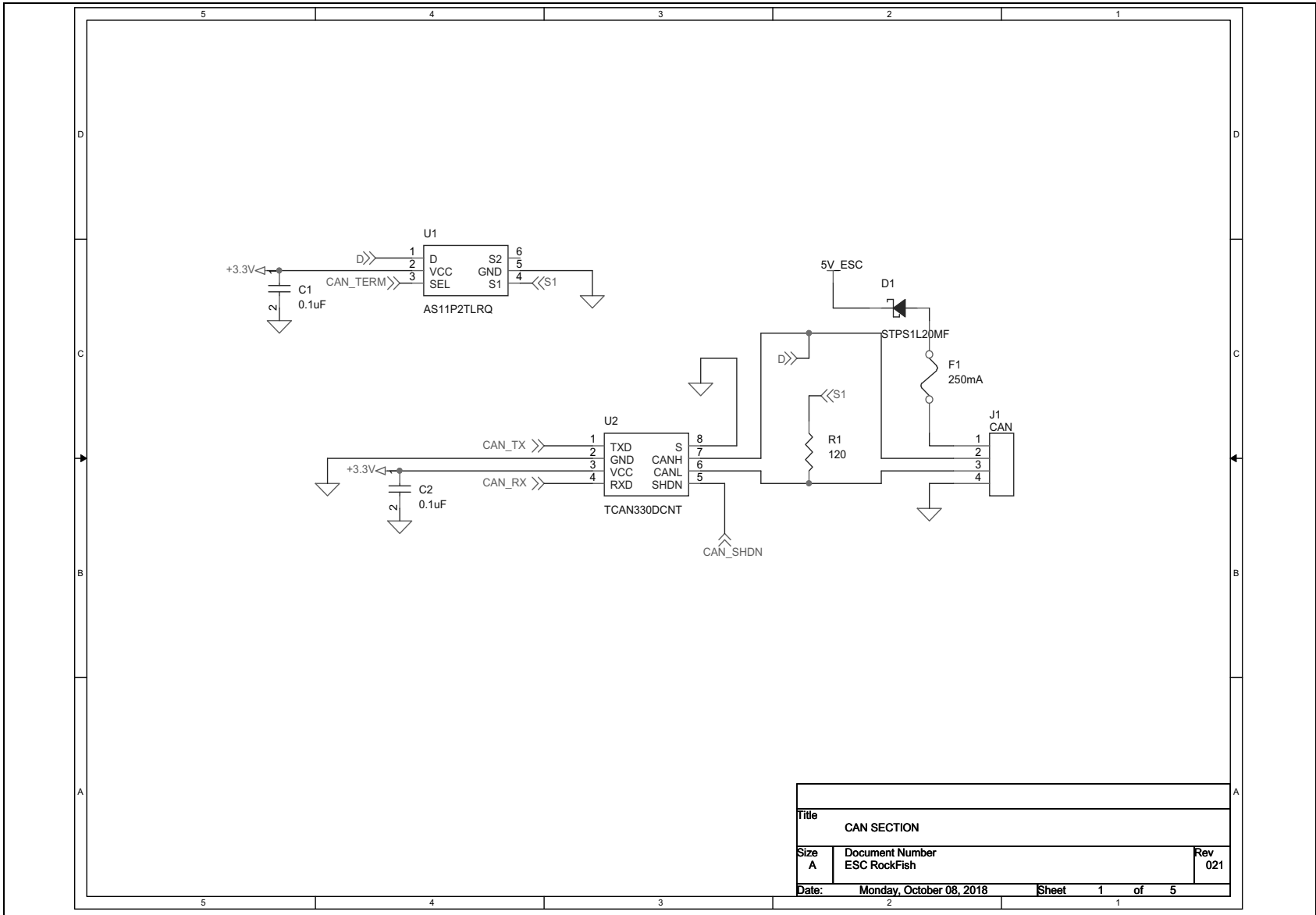
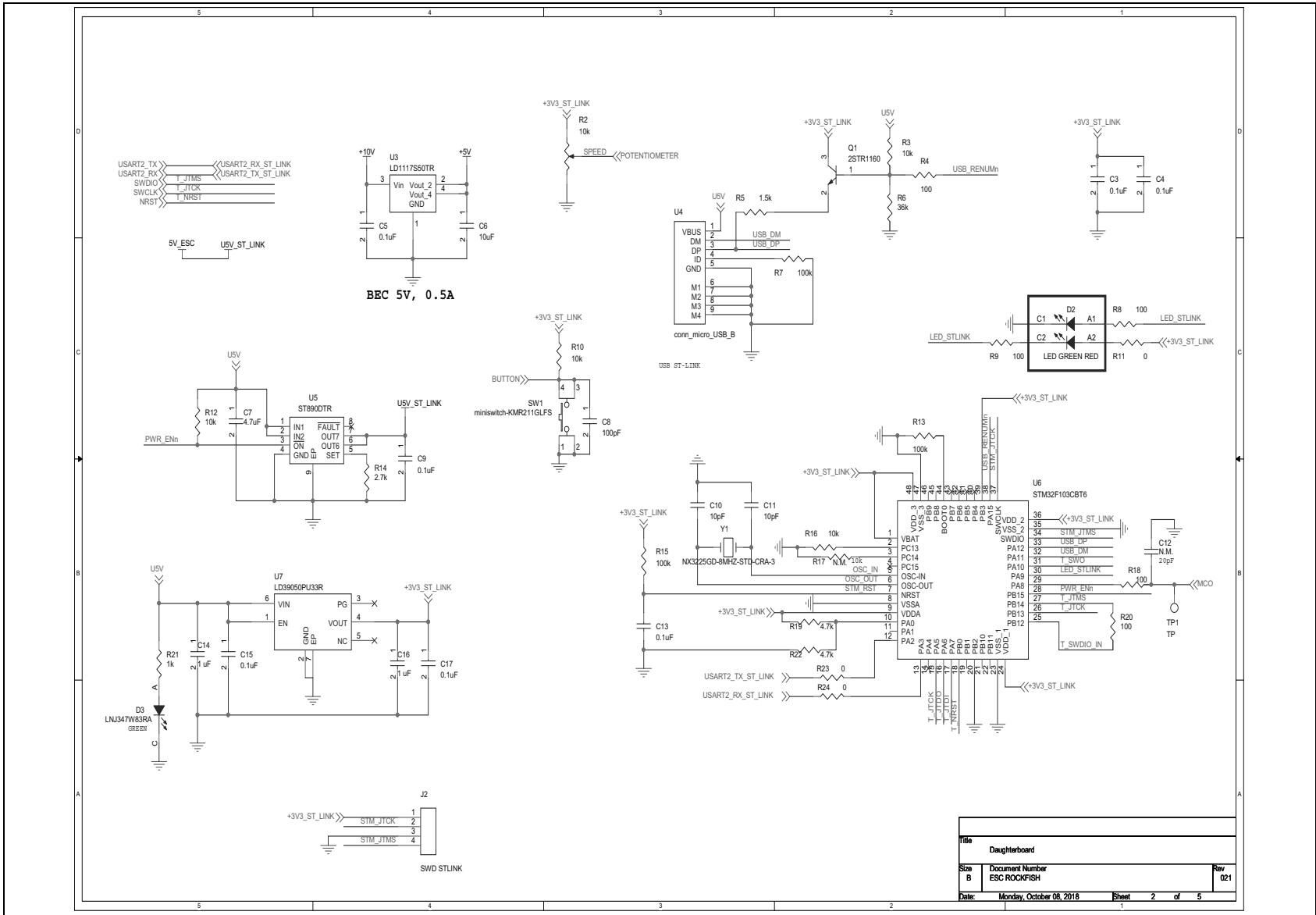



Figure 18. Daughterboard



Title		
Daughterboard		
Size	Document Number	Rev
B	ESC ROCKFISH	021
Date:	Monday, October 08, 2016	Sheet 2 of 5



Figure 19. MCU section

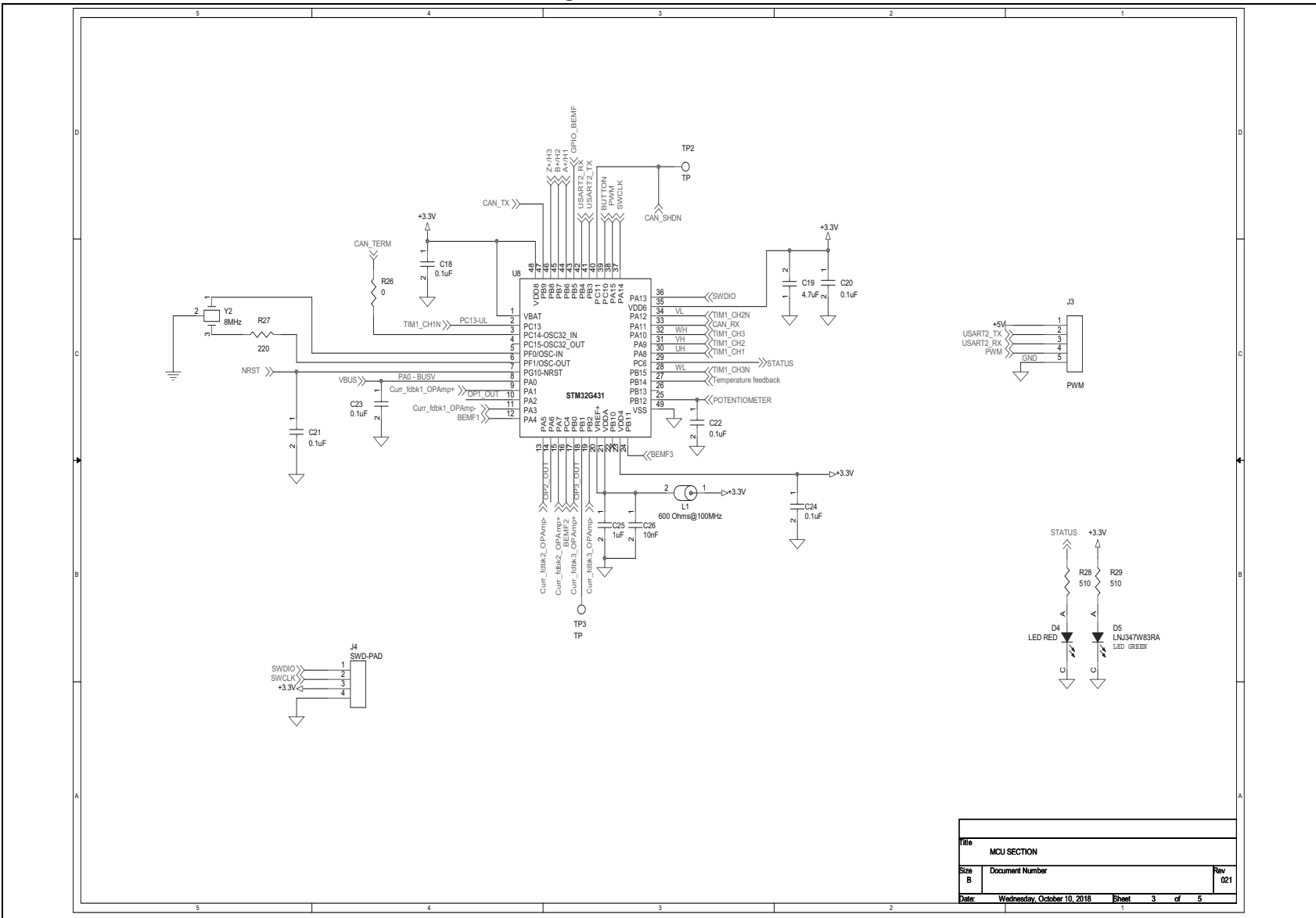
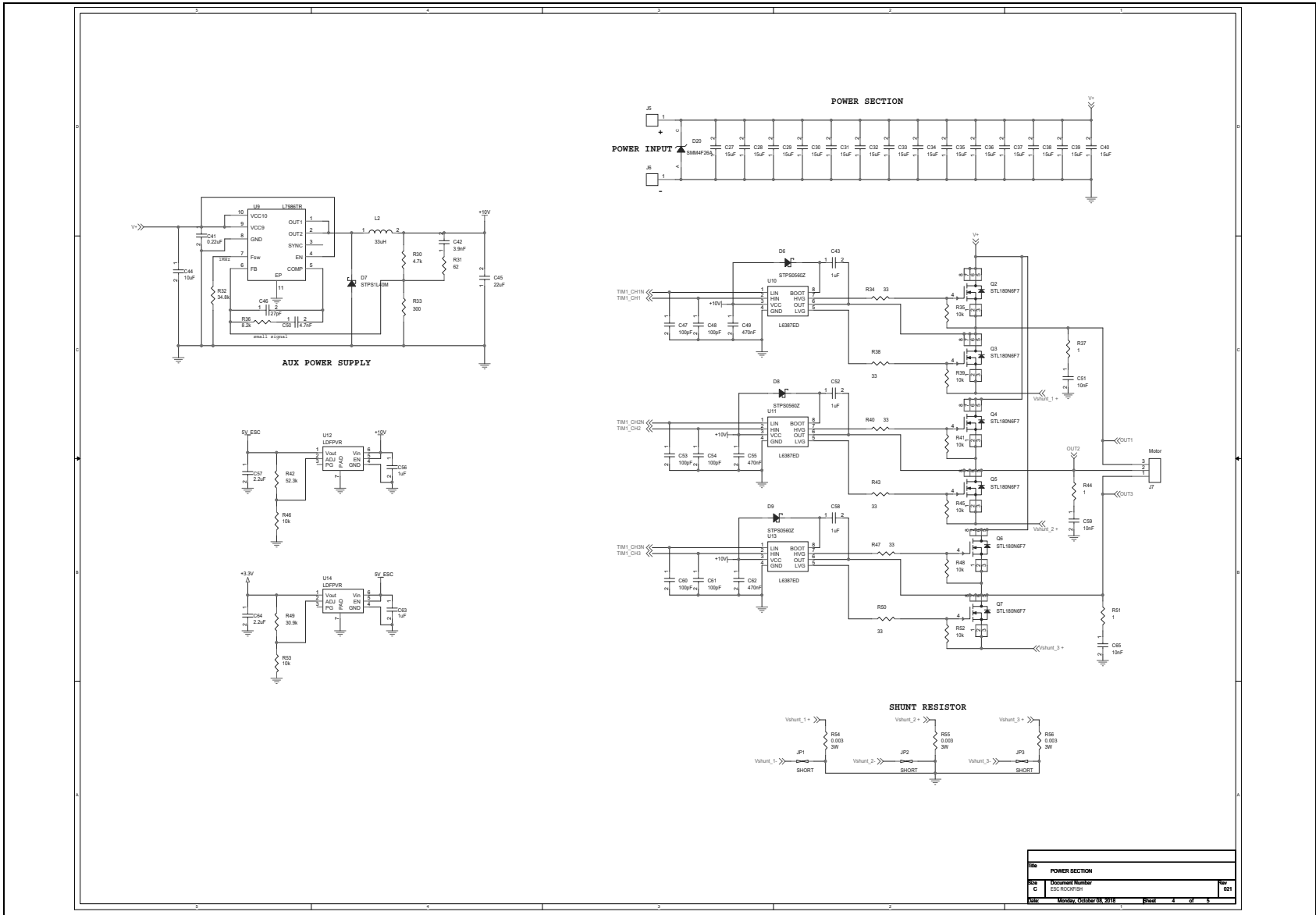

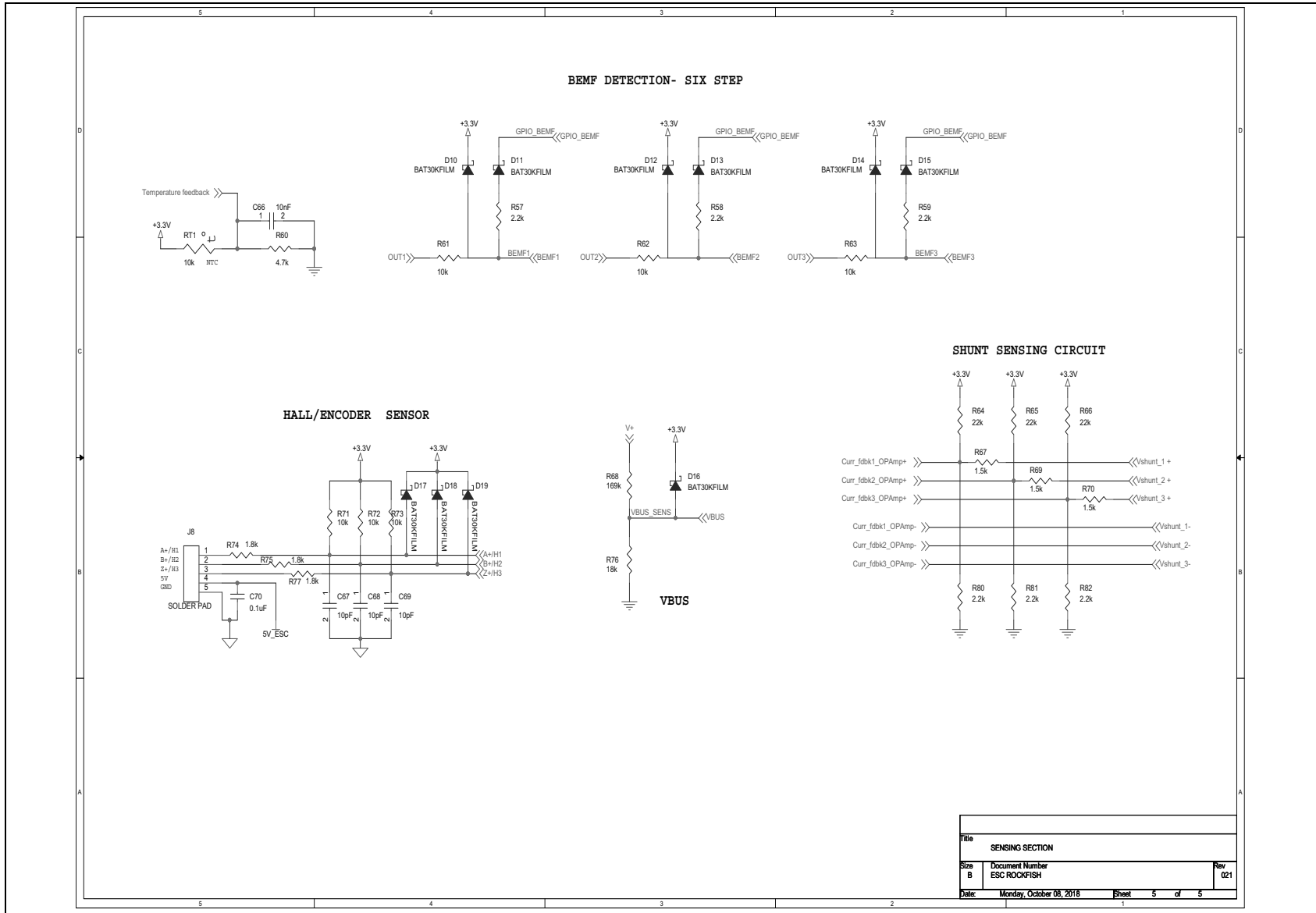

Figure 20. Power section



Doc	POWER SECTION	Rev	021
Doc C	Docnum Number	Doc	ECG ROO/FISH
Date	Monday, October 04, 2010	Page	4 of 1

Figure 21. Sensing section



## Revision history

**Table 7. Document revision history**

Date	Revision	Changes
8-Apr-2019	1	Initial release.
17-Jan-2020	2	Added <a href="#">Section 3.3: Software tool</a> and recommendation note in <a href="#">Section 6</a> introduction.

**IMPORTANT NOTICE – PLEASE READ CAREFULLY**

STMicroelectronics NV and its subsidiaries (“ST”) reserve the right to make changes, corrections, enhancements, modifications, and improvements to ST products and/or to this document at any time without notice. Purchasers should obtain the latest relevant information on ST products before placing orders. ST products are sold pursuant to ST’s terms and conditions of sale in place at the time of order acknowledgement.

Purchasers are solely responsible for the choice, selection, and use of ST products and ST assumes no liability for application assistance or the design of Purchasers’ products.

No license, express or implied, to any intellectual property right is granted by ST herein.

Resale of ST products with provisions different from the information set forth herein shall void any warranty granted by ST for such product.

ST and the ST logo are trademarks of ST. For additional information about ST trademarks, please refer to [www.st.com/trademarks](http://www.st.com/trademarks). All other product or service names are the property of their respective owners.

Information in this document supersedes and replaces information previously supplied in any prior versions of this document.

© 2020 STMicroelectronics – All rights reserved



Компания «ЭлектроПласт» предлагает заключение долгосрочных отношений при поставках импортных электронных компонентов на взаимовыгодных условиях!

Наши преимущества:

- Оперативные поставки широкого спектра электронных компонентов отечественного и импортного производства напрямую от производителей и с крупнейших мировых складов;
- Поставка более 17-ти миллионов наименований электронных компонентов;
- Поставка сложных, дефицитных, либо снятых с производства позиций;
- Оперативные сроки поставки под заказ (от 5 рабочих дней);
- Экспресс доставка в любую точку России;
- Техническая поддержка проекта, помощь в подборе аналогов, поставка прототипов;
- Система менеджмента качества сертифицирована по Международному стандарту ISO 9001;
- Лицензия ФСБ на осуществление работ с использованием сведений, составляющих государственную тайну;
- Поставка специализированных компонентов (Xilinx, Altera, Analog Devices, Intersil, Interpoint, Microsemi, Aeroflex, Peregrine, Syfer, Eurofarad, Texas Instrument, Miteq, Cobham, E2V, MA-COM, Hittite, Mini-Circuits, General Dynamics и др.);

Помимо этого, одним из направлений компании «ЭлектроПласт» является направление «Источники питания». Мы предлагаем Вам помощь Конструкторского отдела:

- Подбор оптимального решения, техническое обоснование при выборе компонента;
- Подбор аналогов;
- Консультации по применению компонента;
- Поставка образцов и прототипов;
- Техническая поддержка проекта;
- Защита от снятия компонента с производства.



#### Как с нами связаться

**Телефон:** 8 (812) 309 58 32 (многоканальный)

**Факс:** 8 (812) 320-02-42

**Электронная почта:** [org@eplast1.ru](mailto:org@eplast1.ru)

**Адрес:** 198099, г. Санкт-Петербург, ул. Калинина, дом 2, корпус 4, литера А.