

NOTES: UNLESS OTHERWISE SPECIFIED

1. CORNERS DRAWN SHARP TO BE R.005 MAXIMUM.
2. EXTERIOR SURFACE TEXTURE TO BE LIGHT EDM FINISH. EQUIVELANT TO MT-11020.
3. INTERIOR SURFACE TEXTURE TO BE: NONE.
4. ALL INSIDE RADII .010R. ALL OUTSIDE RADII .020R MAX, UNLESS OTHERWISE SPECIFIED.
5. ALL EXTERNAL DIMENSIONS AFFECTED BY THE DRAFT APPLY AT THE LARGE END OF THE FEATURE, AND ALL INTERNAL FEATURES AFFECTED BY THE DRAFT APPLY AT THE SMALL END OF THE FEATURE UNLESS OTHERWISE SPECIFIED.
6. 1 DEGREE DRAFT IN THE DIRECTION OF PULL IS PERMISSIBLE UNLESS OTHERWISE SPECIFIED.
7. ASSEMBLY SCREWS FOR THE ENCLOSURE INCLUDED. MOUNTING SCREWS FOR THE PCB ARE SOLD SEPERATELY.
8. MATERIAL / COLOR: ABS PLASTIC IS STANDARD IN BLACK OR WHITE. CUSTOM MATERIALS AND COLORS ARE AVAILABLE UPON REQUEST FOR QUOTE.
9. PCB SIZES ARE RECOMMENDATIONS ONLY. FINAL SIZES AND VERIFICATION OF ITS FIT ARE THE SOLE RESPONSIBILITY OF THE CUSTOMER.
10. STANDARD OR CUSTOM LABEL RECESSES ARE AVAILABLE UPON REQUEST FOR QUOTE.

434313 ENCLOSURE SHOWN WITH 2 PCB SIZE OPTIONS. THIS ENCLOSURE DOES NOT SUPPORT TWO PCB BOARDS AT ONCE.

R E V I S I O N					
REV.	DRAWN BY	ECO No	DESCRIPTION	DATE	APPROVED
A-J	M BOYER		DEVELOPMENT	2009-Aug-24	D.C.
1.0	M BOYER	N/A	UPDATE TO AS-BUILT AND RELEASE	2010-Mar-29	D.C.
1.1	M BOYER	04515	REVISE ASSEMBLY SCREW LENGTH	2015-Sep-14	D.C.
2.0	R CRUZ	03018	REMOVE-FP, INCLUDE FACEPLATE WITH -F(x) OPTIONS	2018-Oct-31	D.C.
2.1	M BOYER	00219	CLARIFY FACEPLATE DETAILS	2019-Jan-28	

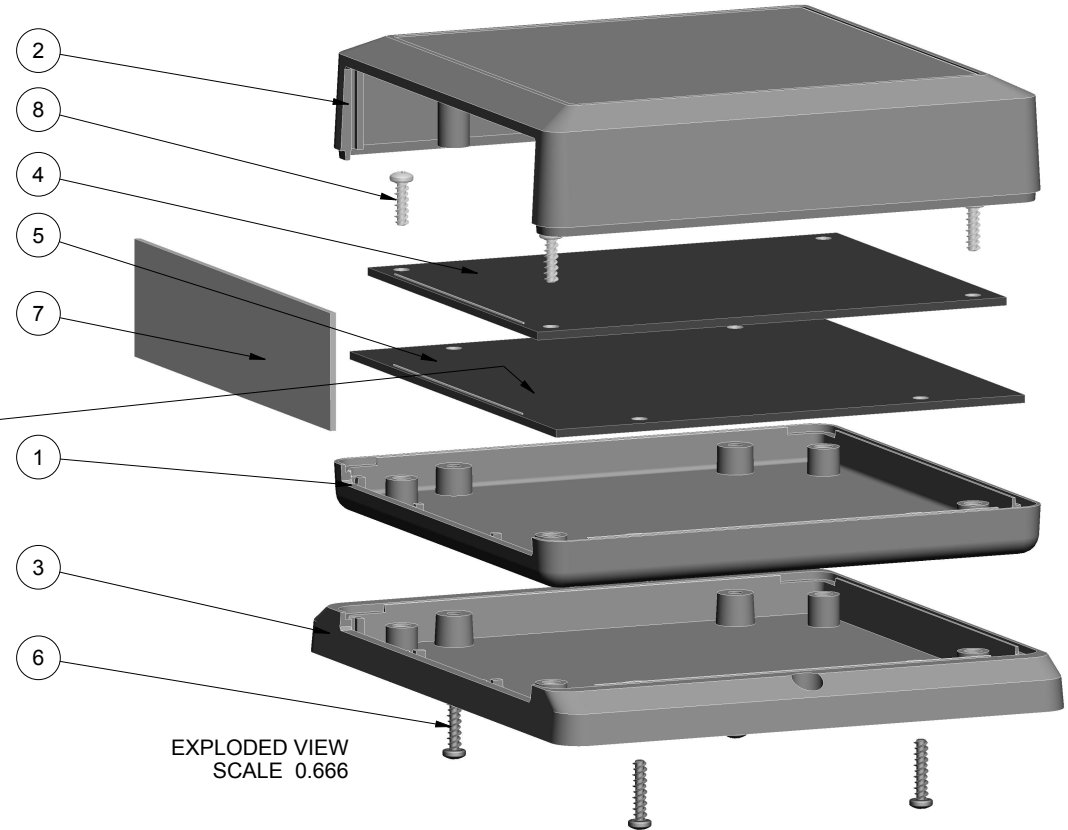

EXPLODED VIEW  
SCALE 0.666

434313(x) CONFIGURATIONS				
	-S	-SW	-F	-FW
434313 COVER	1	1		
434313 COVER w/ FACEPLATE			1	1
434313 BASE	1			
434313 BASE w/ FACEPLATE			1	
434313 WALL BASE		1		
434313 WALL BASE w/ FACEPLATE				1
#4 HiLo SCREW .500"	4	4	4	4
434313 FACEPLATE			1	1

ITEM	FILE NAME	DESCRIPTION	MATERIAL	COLOR	QTY.
8	NO_4_375_SCREW	No4 HiLo x .375" - PCB	#4 HiLo x 3/8"	SOLD SEPARATELY	4
7	434313_FACEPLATE	434313 FACEPLATE - STANDARD	ALUMINUM	INCLUDED	1
6	NO_4_500_SCREW	No4 HiLo x .500" - ASSEMBLY	#4 HiLo x 1/2"	INCLUDED	4
5	434313_PCB-4X4	434313 PCB - REFERENCE	.062" THICK	CUSTOMER SUPPLIED	1
4	434313_PCB-4X3	434313 PCB - REFERENCE	.062" THICK	CUSTOMER SUPPLIED	1
3	434313_WALL-BASE	434313 WALL - STANDARD	ABS	BLACK or WHITE	1
2	434313_COVER	434313 COVER - STANDARD	ABS	BLACK or WHITE	1
1	434313_BASE	434313 BASE - STANDARD	ABS	BLACK or WHITE	1

BILL OF MATERIALS

THIRD ANGLE PROJECTION  
DO NOT SCALE DRAWING

TOLERANCES: UNLESS OTHERWISE SPECIFIED  
DIMENSIONS ARE IN U.S. INCHES.  
X.XX = .015 X.XXXX = .001  
X.XXX = .010 X.X" = 1"

**NEW AGE ENCLOSURES**

2240 South Thornburg Street Santa Maria, CA. 93455  
ph. (805) 595-1310 fax (805) 595-1024

www.newageenclosures.com

Customer's Part No: 434313X

APPROVAL BY DATE

CHECK

ENG.

SCALE AS NOTED

DRAWN BY M BOYER 2009-Aug-24

**SQUARE UTIL. - STANDARD  
SXX-434313X-XXX**

SIZE A DRAWING NAME 434313X\_R2\_1 SHEET 1 OF 8 REV.DOC 2.1

NOTICE: THE INFORMATION AND DATA CONTAINED HEREIN IS CONSIDERED PROPRIETARY TO ALLTEC INTEGRATED MFG INC & SHALL REMAIN THE EXCLUSIVE PROPERTY OF ALLTEC INTEGRATED MFG INC. THE HOLDER WILL ASSUME CUSTODY AND CONTROL THAT THIS DOCUMENT WILL NOT BE COPIED, REPRODUCED, OR DISCLOSED WITHOUT THE EXPRESS WRITTEN CONSENT OF ALLTEC INTEGRATED MFG INC. NOT CONSTITUTE A GRANT TO MANUFACTURE ANY ITEMS. © 2017

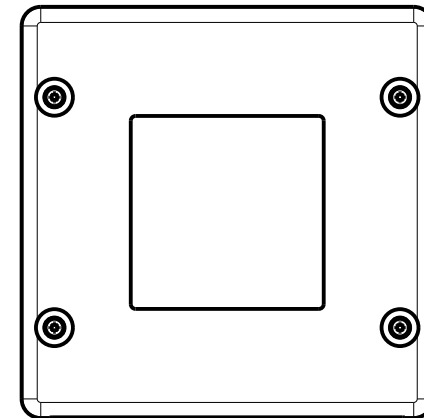
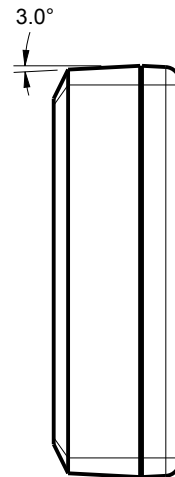
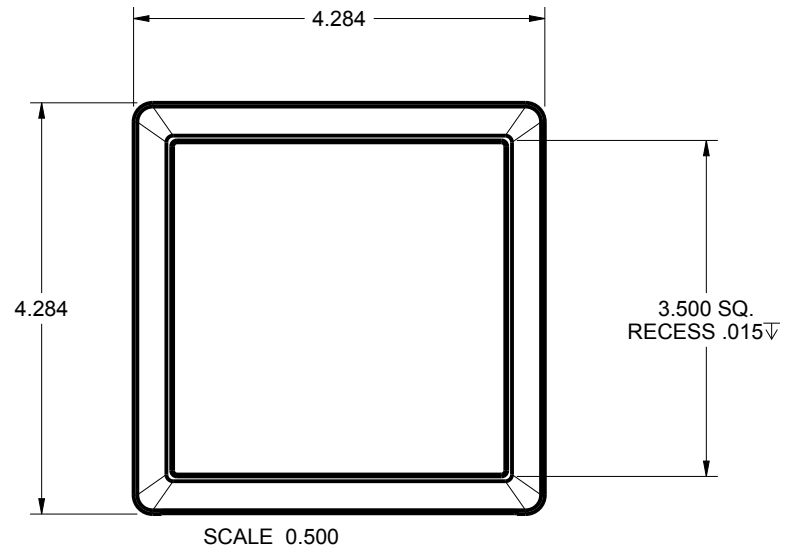

THIS ENCLOSURE CAN BE MOLDED WITH OR WITHOUT THE FACEPLATE OPENING. ASK YOUR SALES REP FOR DETAILS.

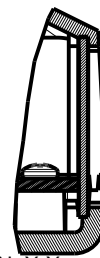
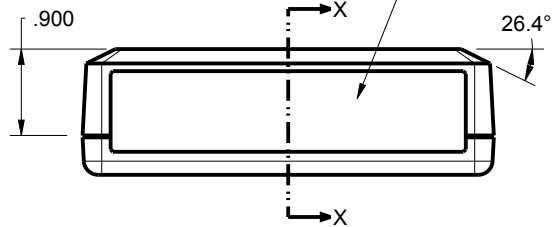

SECTION X-X  
SCALE 1.000

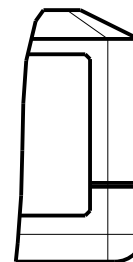

DETAIL A  
SCALE 1.000

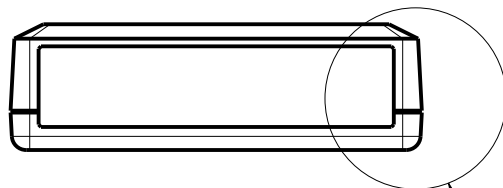

SEE DETAIL A

TOLERANCES: UNLESS OTHERWISE SPECIFIED  
DIMENSIONS ARE IN U.S. INCHES.  
X.XX = .015 X.XXXX = .001  
X.XXX = .010 X.X° = 1°

NEW AGE ENCLOSURES

Customer's Part No: 434313X

APPROVAL	BY	DATE
CHECK		
ENG.		
SCALE	AS NOTED	

DRAWN BY  
M BOYER

2009-Aug-24

**NEW AGE ENCLOSURES**

2240 South Thornburg Street Santa Maria, CA. 93455  
ph. (805) 595-1310 fax (805) 595-1024  
[www.newageenclosures.com](http://www.newageenclosures.com)

SQUARE UTIL. - STANDARD  
SXX-434313X-XXX

SIZE A  
DRAWING NAME  
434313X\_R2\_1

SHEET 2 OF 8  
REV.DOC 2.1

# 434313 COVER

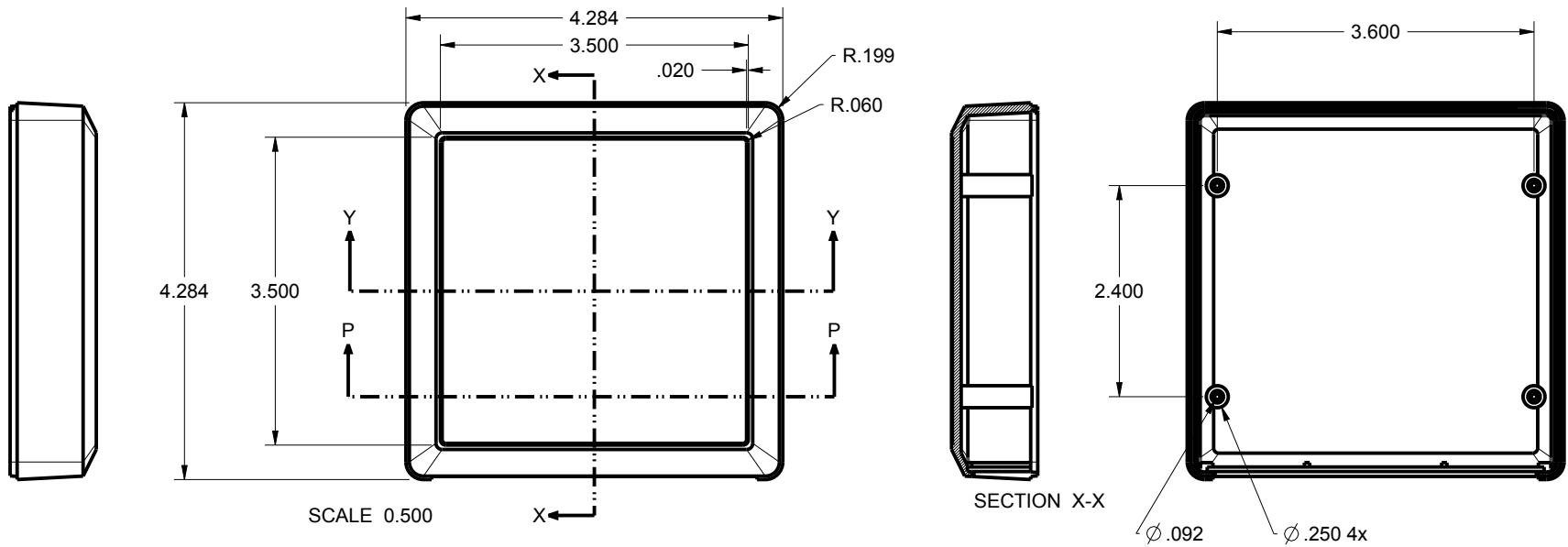

SCALE 0.500

SECTION X-X

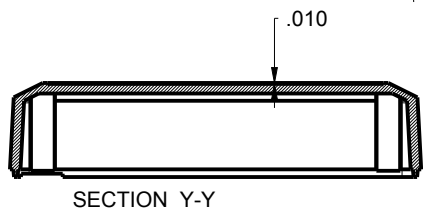
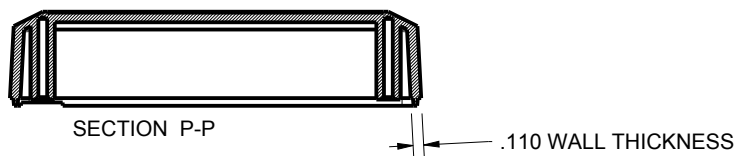
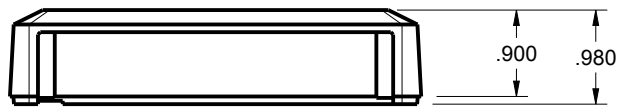

TOLERANCES: UNLESS OTHERWISE SPECIFIED DIMENSIONS ARE IN U.S. INCHES.  
 X.XX = .015 X.XXXX = .001  
 X.XXX = .010 X.X° = 1°

NEW AGE ENCLOSURES  
 Customer's Part No: 434313X

APPROVAL	BY	DATE
CHECK		
ENG.		
SCALE	AS NOTED	
DRAWN BY	M BOYER	
	2009-Aug-24	

**NEW AGE ENCLOSURES**  
 2240 South Thornburg Street Santa Maria, CA. 93455  
 ph. (805) 595-1310 fax (805) 595-1024  
[www.newageenclosures.com](http://www.newageenclosures.com)

**SQUARE UTIL. - STANDARD**  
**SXX-434313X-XXX**

SIZE	DRAWING NAME	SHEET	REV.DOC
A	434313X_R2_1	3 OF 8	2.1

# 434313 BASE

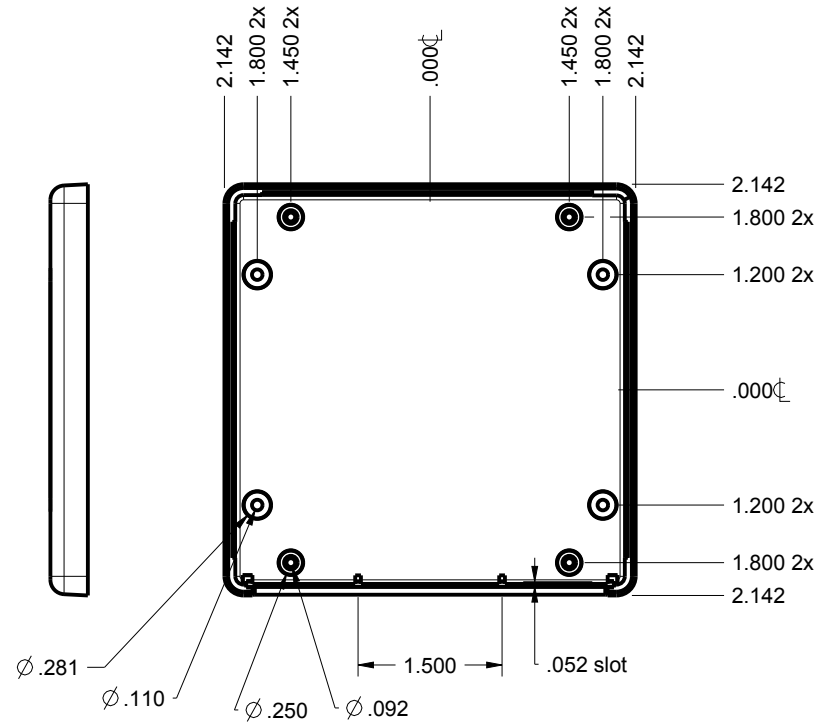
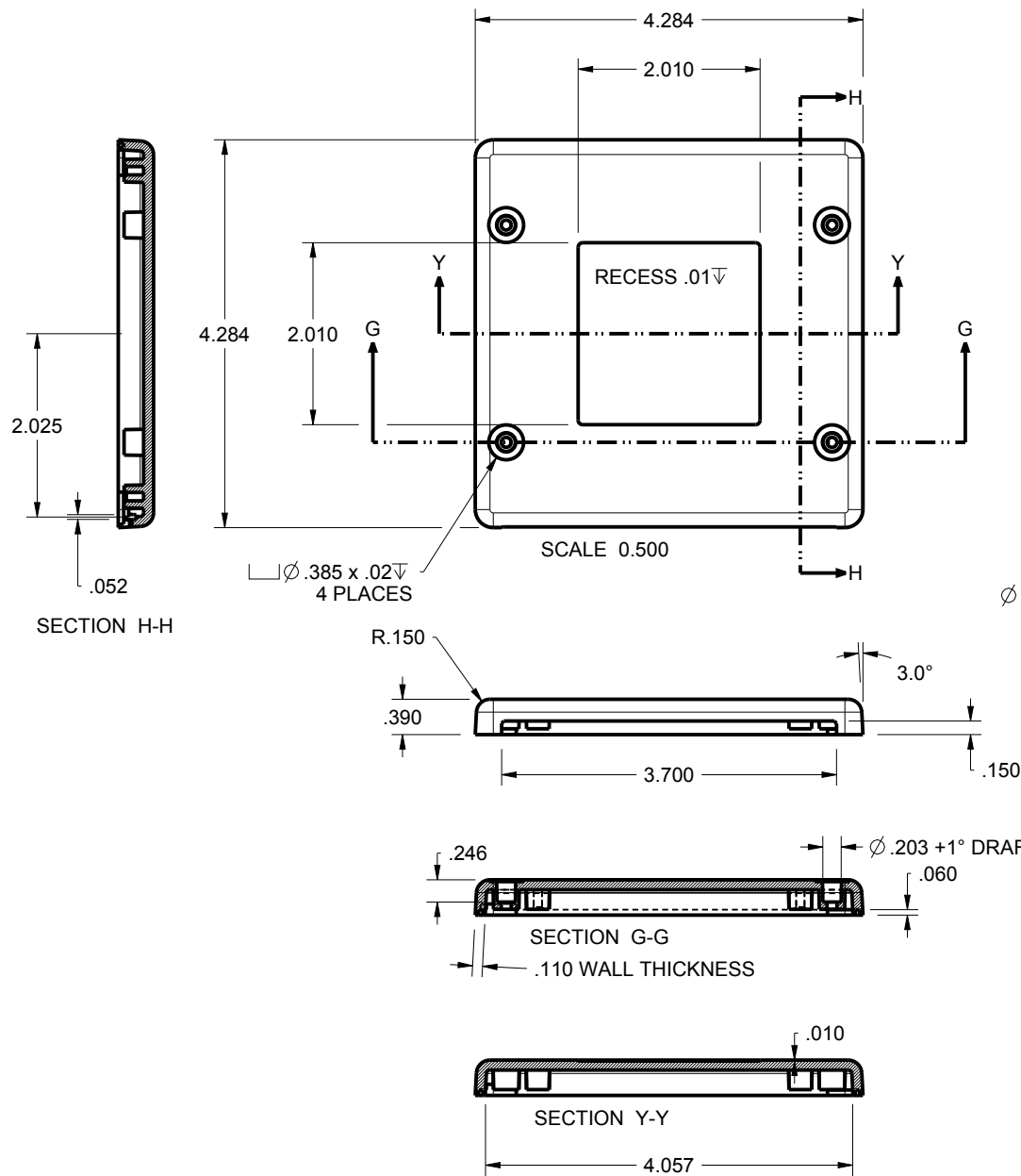

TOLERANCES: UNLESS OTHERWISE SPECIFIED DIMENSIONS ARE IN U.S. INCHES.  
 X.XX = .015 X.XXXX = .001  
 X.XXX = .010 X.X° = 1°

NEW AGE ENCLOSURES  
 Customer's Part No: 434313X

APPROVAL	BY	DATE
CHECK		
ENG.		
SCALE	AS NOTED	
DRAWN BY	M BOYER	
	2009-Aug-24	

**NEW AGE ENCLOSURES**  
 2240 South Thornburg Street Santa Maria, CA. 93455  
 ph. (805) 595-1310 fax (805) 595-1024  
[www.newageenclosures.com](http://www.newageenclosures.com)

**SQUARE UTIL. - STANDARD  
 SXX-434313X-XXX**

SIZE	DRAWING NAME	SHEET	REV.DOC
A	434313X_R2_1	4 OF 8	2.1

434313 WALL

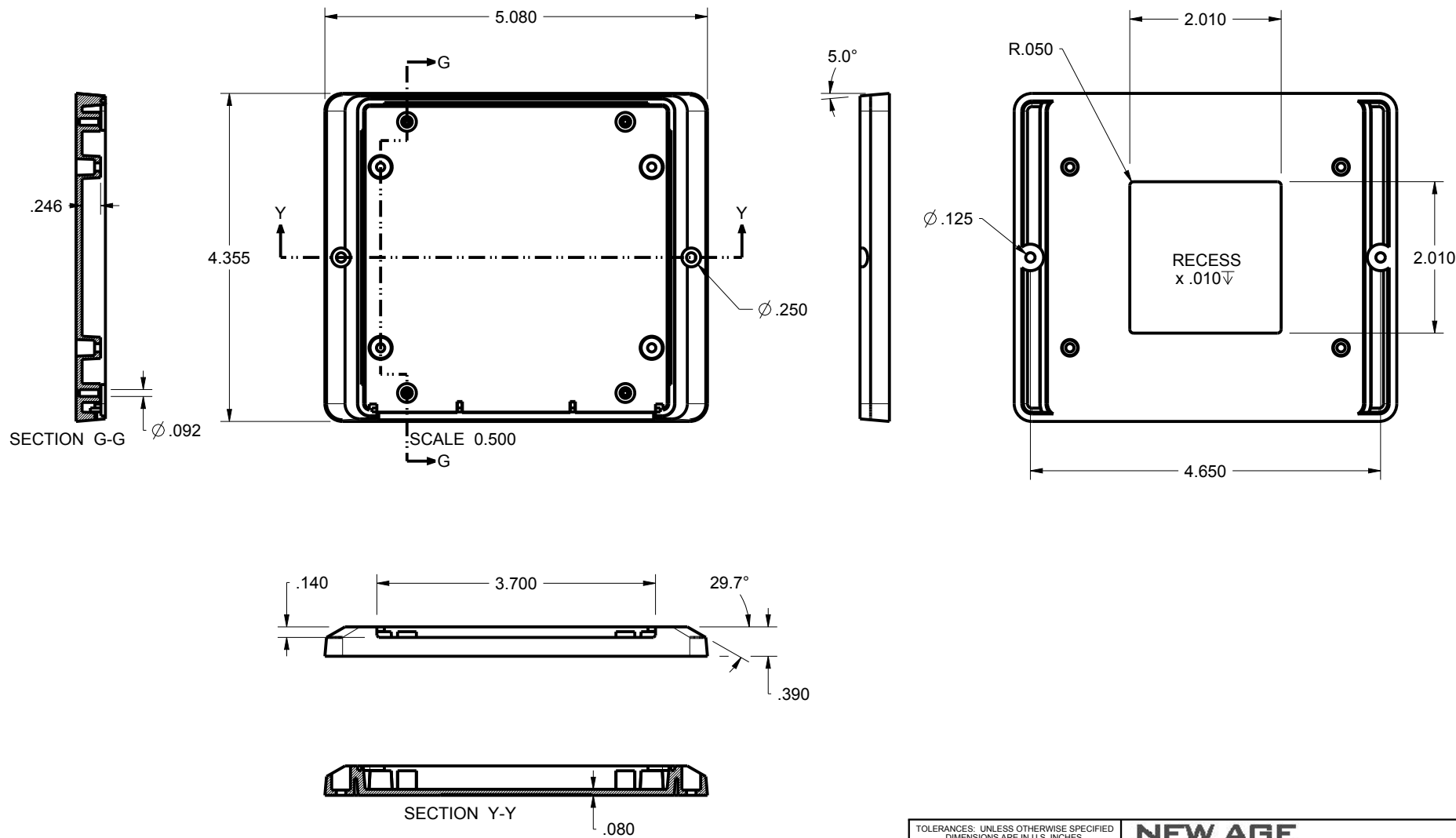

TOLERANCES: UNLESS OTHERWISE SPECIFIED  
DIMENSIONS ARE IN U.S. INCHES.

X.XX = .015 X.XXXX = .001  
X.XXX = .010 X.X° = 1°

APPROVAL	BY	DATE
CHECK		
ENG.		
SCALE	AS NOTED	
DRAWN BY	M BOYER	
	2009-Aug-24	

**NEW AGE ENCLOSURES**  
 2240 South Thornburg Street Santa Maria, CA. 93455  
 ph. (805) 595-1310 fax (805) 595-1024  
[www.newageenclosures.com](http://www.newageenclosures.com)

**SQUARE UTIL. - STANDARD  
 SXX-434313X-XXX**

SIZE	DRAWING NAME	SHEET	REV.DOC
A	434313X_R2_1	5 OF 8	2.1

# 434313 FACE PLATE

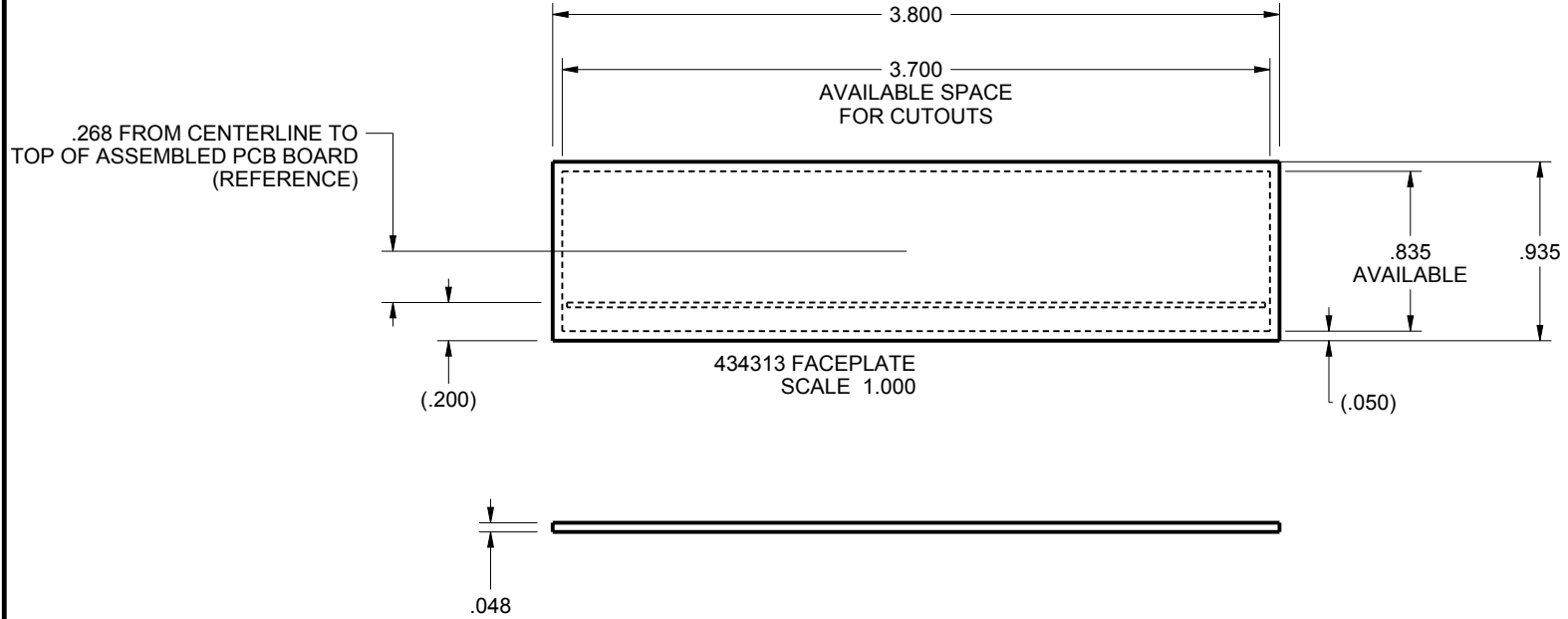

TOLERANCES: UNLESS OTHERWISE SPECIFIED  
DIMENSIONS ARE IN U.S. INCHES.  
X.XX = .015 X.XXXX = .001  
X.XXX = .010 X.X° = 1°

NEW AGE ENCLOSURES  
Customer's Part No: 434313X

APPROVAL	BY	DATE
CHECK		
ENG.		
SCALE	AS NOTED	

DRAWN BY	2009-Aug-24
M BOYER	

**NEW AGE ENCLOSURES**  
2240 South Thornburg Street Santa Maria, CA. 93455  
ph. (805) 595-1310 fax (805) 595-1024  
www.newageenclosures.com

**SQUARE UTIL. - STANDARD  
SXX-434313X-XXX**

SIZE	DRAWING NAME	SHEET	REV.DOC
A	434313X_R2_1	6 OF 8	2.1

**434313 PCB - CUSTOMER SUPPLIED**  
 PCB SIZES ARE RECOMMENDATIONS ONLY. FINAL SIZES AND VERIFICATION OF IT'S FIT ARE THE SOLE RESPONSIBILITY OF THE OEM.  
 SEE SHEET 4 FOR POST CLEARANCE DETAILS.  
 ENCLOSURE DESIGNED TO ACCOMODATE ONE OF THE TWO PCB CONFIGURATIONS SHOWN BELOW (NOT BOTH AT THE SAME TIME).

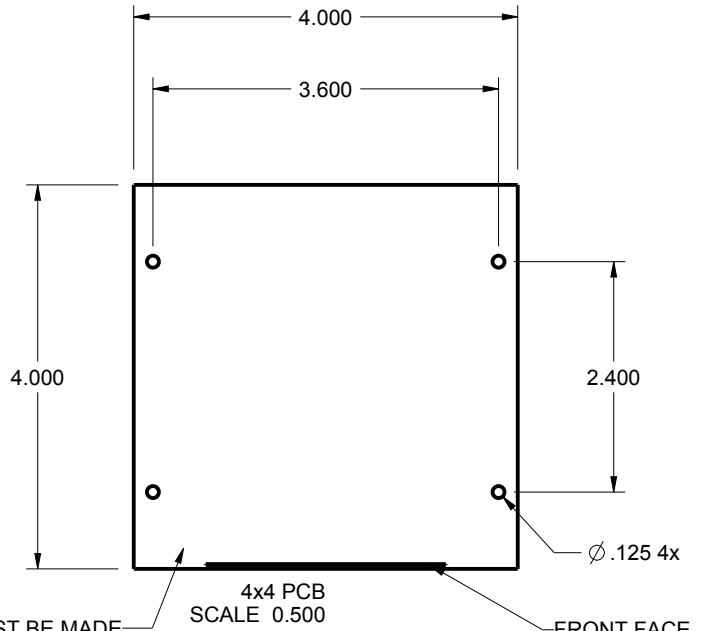

ALLOWANCES MUST BE MADE FOR THE EXTRA PCB POSTS IN ENCLOSURE OR POSTS SHOULD BE CLIPPED BY CUSTOMER.

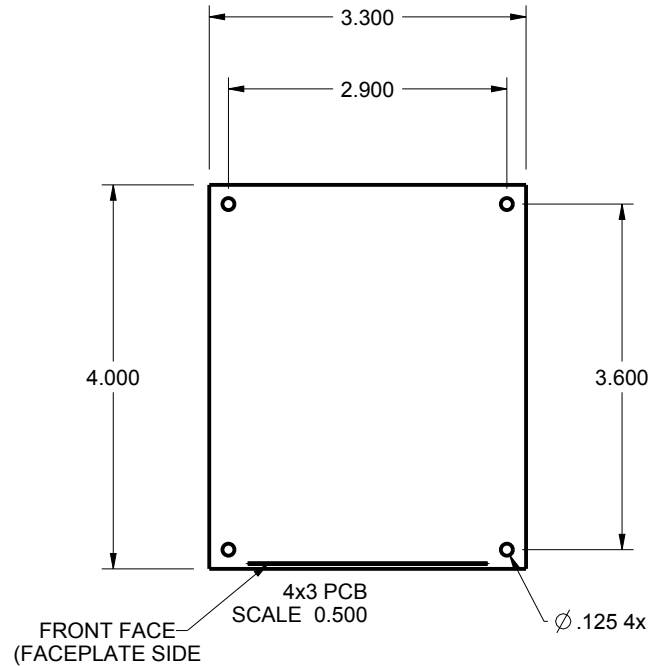

TOLERANCES: UNLESS OTHERWISE SPECIFIED DIMENSIONS ARE IN U.S. INCHES.  
 X.XX = .015 X.XXXX = .001  
 X.XXX = .010 X.X° = 1°

NEW AGE ENCLOSURES  
 Customer's Part No: 434313X

APPROVAL	BY	DATE
CHECK		
ENG.		
SCALE	AS NOTED	
DRAWN BY	2009-Aug-24	
M BOYER		

**NEW AGE ENCLOSURES**  
 2240 South Thornburg Street Santa Maria, CA. 93455  
 ph. (805) 595-1310 fax (805) 595-1024  
[www.newageenclosures.com](http://www.newageenclosures.com)

**SQUARE UTIL. - STANDARD**  
**SXX-434313X-XXX**

SIZE	DRAWING NAME	SHEET	REV.DOC
A	434313X_R2_1	7 OF 8	2.1

## 2nd OPERATION DETAILS

NEW AGE ENCLOSURES DELIVERS YOUR ENCLOSURE MARKET-READY WITH IN-HOUSE  
CNC MACHINING, PAD PRINTING, ASSEMBLY, AND FULFILLEMENT.  
ALL SURFACES AND AREAS ARE AVAILABLE FOR CNC ALTERATION BY NEW AGE ENCLOSURES  
CALL (805) 595-1310 FOR PRICING AND SCHEDULE.  
THE INSIDE RADIUS OF ANY MACHINED FEATURES SHOULD BE NO SMALLER THAN .031"

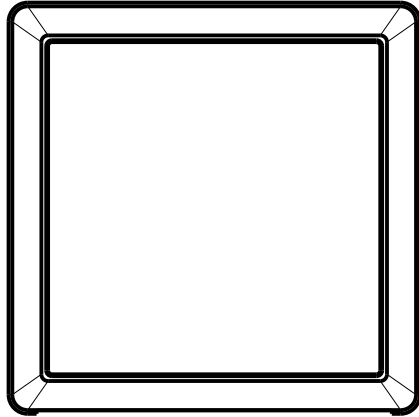

434313 COVER  
SCALE 0.500

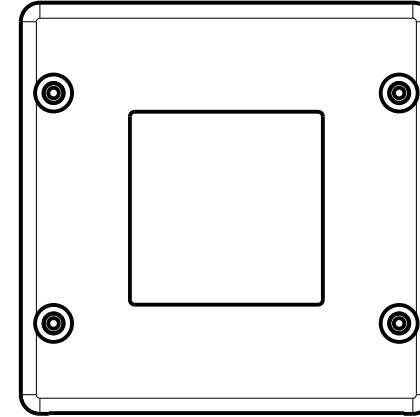

434313 BASE  
SCALE 0.500

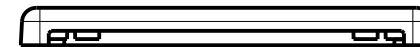

### SXX-434313-XXX COVER - ABS, BLACK

STEP NO	DESCRIPTION	CUTTER	FIXTURE	ORIENTATION	PROGRAM
1-C-C1	-	T2 = .062" EM	326	-	o1000
2-C-C2	-	T2 = .062" EM	326	-	o1000
3-C-C3	-	T2 = .062" EM	326	-	o1000

### SXX-434313-XXX BASE - ABS, BLACK

STEP NO	DESCRIPTION	CUTTER	FIXTURE	ORIENTATION	PROGRAM
1-B-C1	-	T2 = .062" EM	234	-	o1000
2-B-C2	-	T2 = .062" EM	234	-	o1000
3-B-C3	-	T2 = .062" EM	234	-	o1000

TOLERANCES: UNLESS OTHERWISE SPECIFIED  
DIMENSIONS ARE IN U.S. INCHES.  
X.XX = .015 X.XXXX = .001  
X.XXX = .010 XX° = 1°

**NEW AGE ENCLOSURES**

Customer's Part No: 434313X

APPROVAL	BY	DATE
CHECK		
ENG.		
SCALE	AS NOTED	
DRAWN BY		
M BOYER	2009-Aug-24	

NEW AGE  
ENCLOSURES

2240 South Thornburg Street Santa Maria, CA. 93455  
ph. (805) 595-1310 fax (805) 595-1024  
[www.newageenclosures.com](http://www.newageenclosures.com)

SQUARE UTIL. - STANDARD  
SXX-434313X-XXX

SIZE	DRAWING NAME	SHEET	REV.DOC
A	434313X_R2_1	8 OF 8	2.1





Компания «ЭлектроПласт» предлагает заключение долгосрочных отношений при поставках импортных электронных компонентов на взаимовыгодных условиях!

Наши преимущества:

- Оперативные поставки широкого спектра электронных компонентов отечественного и импортного производства напрямую от производителей и с крупнейших мировых складов;
- Поставка более 17-ти миллионов наименований электронных компонентов;
- Поставка сложных, дефицитных, либо снятых с производства позиций;
- Оперативные сроки поставки под заказ (от 5 рабочих дней);
- Экспресс доставка в любую точку России;
- Техническая поддержка проекта, помощь в подборе аналогов, поставка прототипов;
- Система менеджмента качества сертифицирована по Международному стандарту ISO 9001;
- Лицензия ФСБ на осуществление работ с использованием сведений, составляющих государственную тайну;
- Поставка специализированных компонентов (Xilinx, Altera, Analog Devices, Intersil, Interpoint, Microsemi, Aeroflex, Peregrine, Syfer, Eurofarad, Texas Instrument, Miteq, Cobham, E2V, MA-COM, Hittite, Mini-Circuits, General Dynamics и др.);

Помимо этого, одним из направлений компании «ЭлектроПласт» является направление «Источники питания». Мы предлагаем Вам помощь Конструкторского отдела:

- Подбор оптимального решения, техническое обоснование при выборе компонента;
- Подбор аналогов;
- Консультации по применению компонента;
- Поставка образцов и прототипов;
- Техническая поддержка проекта;
- Защита от снятия компонента с производства.



#### Как с нами связаться

**Телефон:** 8 (812) 309 58 32 (многоканальный)

**Факс:** 8 (812) 320-02-42

**Электронная почта:** [org@eplast1.ru](mailto:org@eplast1.ru)

**Адрес:** 198099, г. Санкт-Петербург, ул. Калинина, дом 2, корпус 4, литера А.