

Cree® XLamp® XT-E LEDs

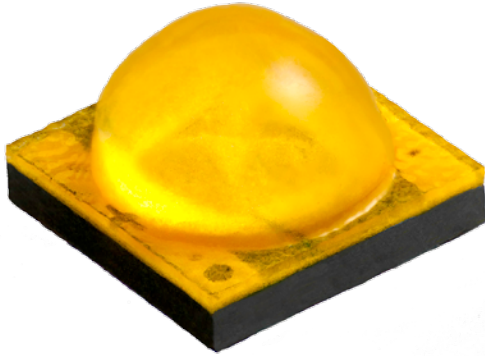

PRODUCT DESCRIPTION

XLamp® XT-E is Cree’s highest performing silicon carbide-based LED technology, delivered in Cree’s industry-standard XP/XT packaging. XT-E White sets the new standard for high performance and dramatically lowers system cost. XT-E Royal Blue is Cree’s highest performing source of royal blue light for remote-phosphor applications.

Cree XLamp LEDs bring high performance and quality of light to a wide range of lighting applications, including remote-phosphor, color-changing, portable and personal, outdoor, indoor-directional, transportation, stage and studio, commercial and emergency-vehicle lighting.

FEATURES

- Available in white, 80-CRI min white, 70-CRI min white and royal blue
- Warm white available in 85- and 90-CRI min.
- New: available in 2200 K CCT
- Binned at 85 °C
- Cool white efficacy of up to 148 lm/W (@ 85 °C, 350 mA)
- Royal Blue wall plug efficiency of up to 53% (@ 85 °C, 350 mA)
- Wide viewing angle: 115-140°
- Thermal resistance: 5 °C/W
- Maximum drive current: 1.5 A
- Electrically neutral thermal path
- Vf binning supported for XT-E White and Royal Blue
- XT-E Royal Blue sorted into 2.5-nm wavelength bins
- Unlimited floor life at ≤ 30 °C/85% RH
- Reflow solderable - JEDEC J-STD-020C compatible
- RoHS- and REACH-compliant
- UL-recognized component (E349212)



TABLE OF CONTENTS

| | |
|---|----|
| Product Characteristics..... | 2 |
| Flux Characteristics..... | 3 |
| Relative Spectral Power Distribution | 5 |
| Relative Luminous Flux vs. Junction Temperature..... | 6 |
| Electrical Characteristics..... | 7 |
| Relative Luminous Flux vs. Current | 7 |
| Relative Chromaticity vs. Current and Temperature | 9 |
| Typical Spatial Distribution..... | 10 |
| Thermal Design..... | 11 |
| Reflow Soldering Characteristics . | 12 |
| Notes..... | 13 |
| Mechanical Dimensions..... | 14 |
| Tape and Reel | 15 |
| Packaging..... | 16 |

NOTE: For remote phosphor applications, a separate license to certain Cree patents is required.

PRODUCT CHARACTERISTICS

| Characteristics | Unit | Minimum | Typical | Maximum |
|--|---------|---------|---------|---------|
| Thermal resistance, junction to solder point | °C/W | | 5 | |
| Viewing angle (FWHM) - white | degrees | | 115 | |
| Viewing angle (FWHM) - royal blue | degrees | | 140 | |
| Temperature coefficient of voltage | mV/°C | | -2.5 | |
| ESD classification (HBM per Mil-Std-883D) | | | Class 2 | |
| DC forward current | mA | | | 1500 |
| Reverse voltage | V | | | 5 |
| Forward voltage (@ 350 mA, 85 °C) | V | | 2.85 | 3.4 |
| LED junction temperature | °C | | | 150 |

FLUX CHARACTERISTICS - WHITE ($T_j = 85\text{ }^\circ\text{C}$)

The following table provides several base order codes for XLamp XT-E White LEDs. It is important to note that the base order codes listed here are a subset of the total available order codes for the product family. For more order codes, as well as a complete description of the order-code nomenclature, please consult the XLamp XT-E Binning and Labeling document.

| Color | CCT Range | | Base Order Codes Minimum Luminous Flux @ 350 mA | | | Calculated Minimum Luminous Flux (lm)** @ 85 °C | | Order Code |
|------------------------------------|-----------|--------|---|----------------------|-----------------------|---|---------|---------------------------|
| | Min. | Max. | Group | Flux (lm) @ 85 °C | Flux (lm) @ 25 °C* | 700 mA | 1500 mA | |
| Cool White | 5000 K | 8300 K | R3 | 122 | 140 | 217 | 376 | XTEAWT-00-0000-000000F51 |
| | | | R4 | 130 | 149 | 231 | 401 | XTEAWT-00-0000-000000G51 |
| | | | R5 | 139 | 160 | 247 | 428 | XTEAWT-00-0000-000000H51 |
| Outdoor White | 4000 K | 6200 K | R3 | 122 | 140 | 217 | 376 | XTEAWT-00-0000-000000FE3 |
| | | | R4 | 130 | 149 | 231 | 401 | XTEAWT-00-0000-000000GE3 |
| | | | R5 | 139 | 160 | 247 | 428 | XTEAWT-00-0000-000000HE3 |
| Neutral White | 3700 K | 5000 K | R2 | 114 | 131 | 203 | 351 | XTEAWT-00-0000-000000EF4 |
| | | | R3 | 122 | 140 | 217 | 376 | XTEAWT-00-0000-000000FF4 |
| | | | R4 | 130 | 149 | 231 | 401 | XTEAWT-00-0000-000000GF4 |
| Warm White | 2200 K | 3700 K | Q3 | 93.9 | 108 | 167 | 289 | XTEAWT-00-0000-000000LBE7 |
| | | | Q4 | 100 | 115 | 178 | 308 | XTEAWT-00-0000-000000LCE7 |
| | | | Q5 | 107 | 123 | 191 | 330 | XTEAWT-00-0000-000000LDE7 |
| 70 CRI Minimum Neutral White | 2600 K | 8300 K | Q4 | 100 | 115 | 178 | 308 | XTEAWT-00-0000-000000BCE7 |
| | | | Q5 | 107 | 123 | 191 | 330 | XTEAWT-00-0000-000000BDF6 |
| | | | R2 | 114 | 131 | 203 | 351 | XTEAWT-00-0000-000000BEF5 |
| | | | R3 | 122 | 140 | 217 | 376 | XTEAWT-00-0000-000000BFC3 |
| | | | R4 | 130 | 149 | 231 | 401 | XTEAWT-00-0000-000000BG53 |
| 80 CRI Minimum White | 2200 K | 6200 K | Q3 | 93.9 | 108 | 167 | 289 | XTEAWT-00-0000-000000HBE7 |
| | | | Q4 | 100 | 115 | 178 | 308 | XTEAWT-00-0000-000000HCE6 |
| | | | Q5 | 107 | 123 | 191 | 330 | XTEAWT-00-0000-000000HDE5 |
| | | | R2 | 114 | 131 | 203 | 351 | XTEAWT-00-0000-000000HEF4 |
| | | | R3 | 122 | 140 | 217 | 376 | XTEAWT-00-0000-000000HF50 |
| 85-CRI Minimum Warm White | 2600 K | 3700 K | P3 | 73.9 | 85 | 132 | 228 | XTEAWT-00-0000-000000P8E7 |
| | | | P4 | 80.6 | 93 | 144 | 248 | XTEAWT-00-0000-000000P9E7 |
| | | | Q2 | 87.4 | 100 | 156 | 269 | XTEAWT-00-0000-000000PAE7 |
| 90-CRI Minimum Warm White | 2600 K | 3700 K | P3 | 73.9 | 85 | 132 | 228 | XTEAWT-00-0000-000000U8E7 |
| | | | P4 | 80.6 | 93 | 144 | 248 | XTEAWT-00-0000-000000U9E7 |
| | | | Q2 | 87.4 | 100 | 156 | 269 | XTEAWT-00-0000-000000UAE7 |

Notes:

- Cree maintains a tolerance of $\pm 7\%$ on flux and power measurements, ± 0.005 on chromaticity (CCx, CCy) measurements and ± 2 on CRI measurements.
- Typical CRI for Neutral White, 3,700 K - 5,000K CCT is 75.
- Typical CRI for Warm White, 2,600 K - 3,700 K CCT is 80.
- * Flux values @ 25 °C are calculated and for reference only.
- ** Calculated flux values at 700 mA and 1500 mA are for reference only.

FLUX CHARACTERISTICS - ROYAL BLUE ($T_j = 85\text{ }^\circ\text{C}$)

The following table provides order codes for XLamp XT-E Royal Blue LEDs. Additional information on the performance grouping and codes for XT-E Royal Blue LEDs can be found in the XT-E Binning and Labeling document.

| DWL Kit Codes | Dominant Wavelength Range | | | | Order Codes, Minimum Radiant Flux @ 350 mA, $T_j=85\text{ }^\circ\text{C}$ | | |
|---------------|---------------------------|----------|-------|----------|--|---|---|
| | Min. | | Max. | | 500 mW - Radiant Flux Group Code 32 (L) | 525 mW - Radiant Flux Group Code 33 (M) | 550 mW - Radiant Flux Group Code 34 (N) |
| | Group | DWL (nm) | Group | DWL (nm) | | | |
| 01 | D36 | 450 | D57 | 465 | XTEARY-00-0000-000000L01 | XTEARY-00-0000-000000M01 | XTEARY-00-0000-000000N01 |
| 02 | D36 | 450 | D47 | 460 | XTEARY-00-0000-000000L02 | XTEARY-00-0000-000000M02 | XTEARY-00-0000-000000N02 |
| 03 | D46 | 455 | D57 | 465 | XTEARY-00-0000-000000L03 | XTEARY-00-0000-000000M03 | XTEARY-00-0000-000000N03 |
| 04 | D36 | 450 | D37 | 455 | XTEARY-00-0000-000000L04 | XTEARY-00-0000-000000M04 | XTEARY-00-0000-000000N04 |
| 05 | D46 | 455 | D47 | 460 | XTEARY-00-0000-000000L05 | XTEARY-00-0000-000000M05 | XTEARY-00-0000-000000N05 |
| 06 | D56 | 460 | D57 | 465 | XTEARY-00-0000-000000L06 | XTEARY-00-0000-000000M06 | XTEARY-00-0000-000000N06 |
| 07 | D37 | 452.5 | D46 | 457.5 | XTEARY-00-0000-000000L07 | XTEARY-00-0000-000000M07 | XTEARY-00-0000-000000N07 |
| 08 | D47 | 457.5 | D56 | 462.5 | XTEARY-00-0000-000000L08 | XTEARY-00-0000-000000M08 | XTEARY-00-0000-000000N08 |
| 09 | D37 | 452.5 | D56 | 462.5 | XTEARY-00-0000-000000L09 | XTEARY-00-0000-000000M09 | XTEARY-00-0000-000000N09 |

| DWL Kit Codes | Dominant Wavelength Range | | | | Order Codes, Minimum Radiant Flux @ 350 mA, $T_j=85\text{ }^\circ\text{C}$ | |
|---------------|---------------------------|----------|-------|----------|--|---|
| | Min. | | Max. | | 575 mW - Radiant Flux Group Code 35 (P) | 600 mW - Radiant Flux Group Code 36 (Q) |
| | Group | DWL (nm) | Group | DWL (nm) | | |
| 01 | D36 | 450 | D57 | 465 | XTEARY-00-0000-000000P01 | XTEARY-00-0000-000000Q01 |
| 02 | D36 | 450 | D47 | 460 | XTEARY-00-0000-000000P02 | XTEARY-00-0000-000000Q02 |
| 03 | D46 | 455 | D57 | 465 | XTEARY-00-0000-000000P03 | |
| 04 | D36 | 450 | D37 | 455 | XTEARY-00-0000-000000P04 | XTEARY-00-0000-000000Q04 |
| 05 | D46 | 455 | D47 | 460 | XTEARY-00-0000-000000P05 | |
| 06 | D56 | 460 | D57 | 465 | | |
| 07 | D37 | 452.5 | D46 | 457.5 | XTEARY-00-0000-000000P07 | |
| 08 | D47 | 457.5 | D56 | 462.5 | | |
| 09 | D37 | 452.5 | D56 | 462.5 | XTEARY-00-0000-000000P09 | |

- Note:
- Cree maintains a tolerance of $\pm 7\%$ on flux and power measurements, ± 0.005 on chromaticity (CCx, CCy) measurements and ± 2 on CRI measurements.

RELATIVE SPECTRAL POWER DISTRIBUTION - WHITE

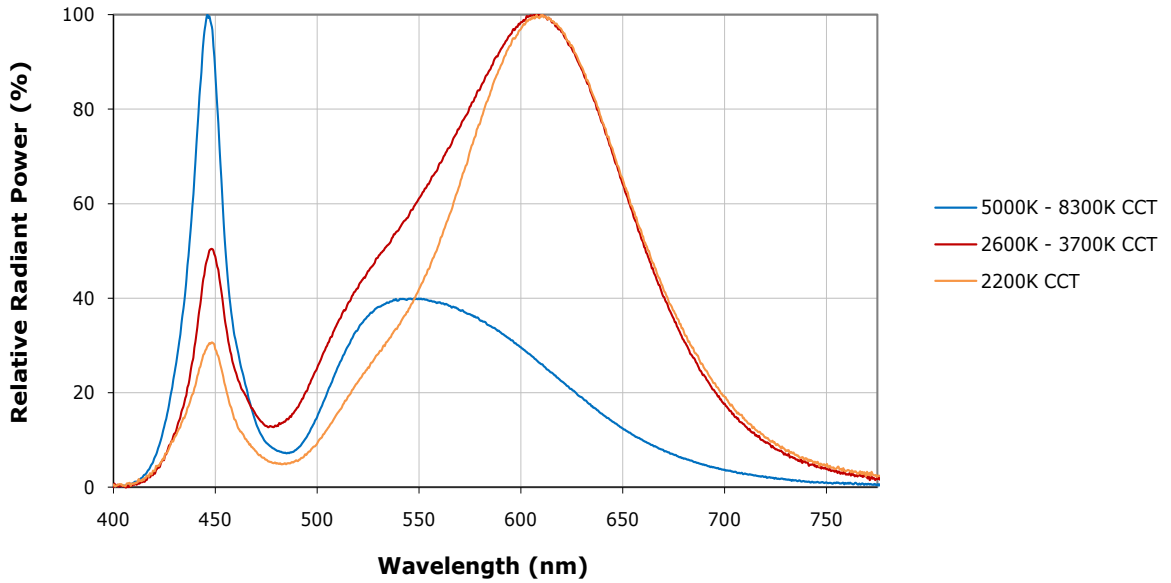

RELATIVE SPECTRAL POWER DISTRIBUTION - ROYAL BLUE

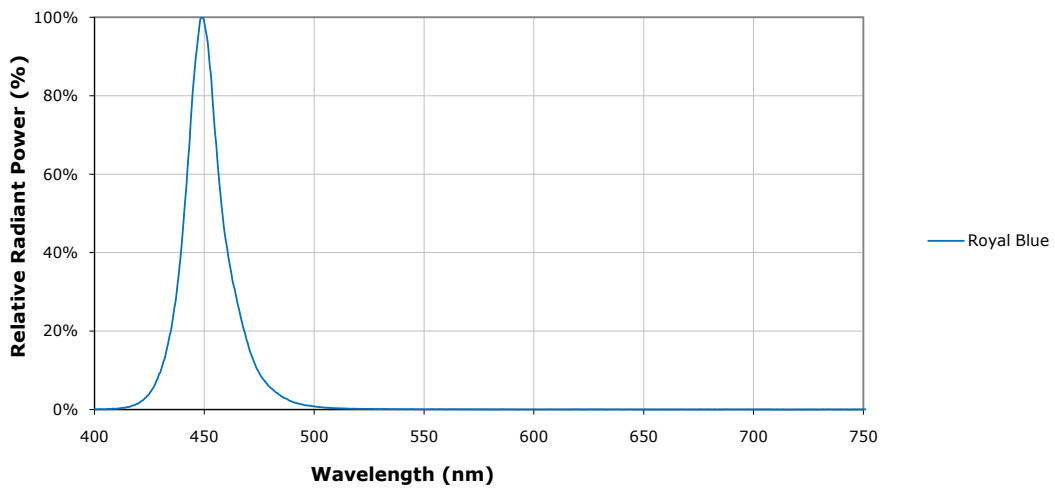

RELATIVE LUMINOUS FLUX VS. JUNCTION TEMPERATURE ($I_F = 350$ mA) - WHITE

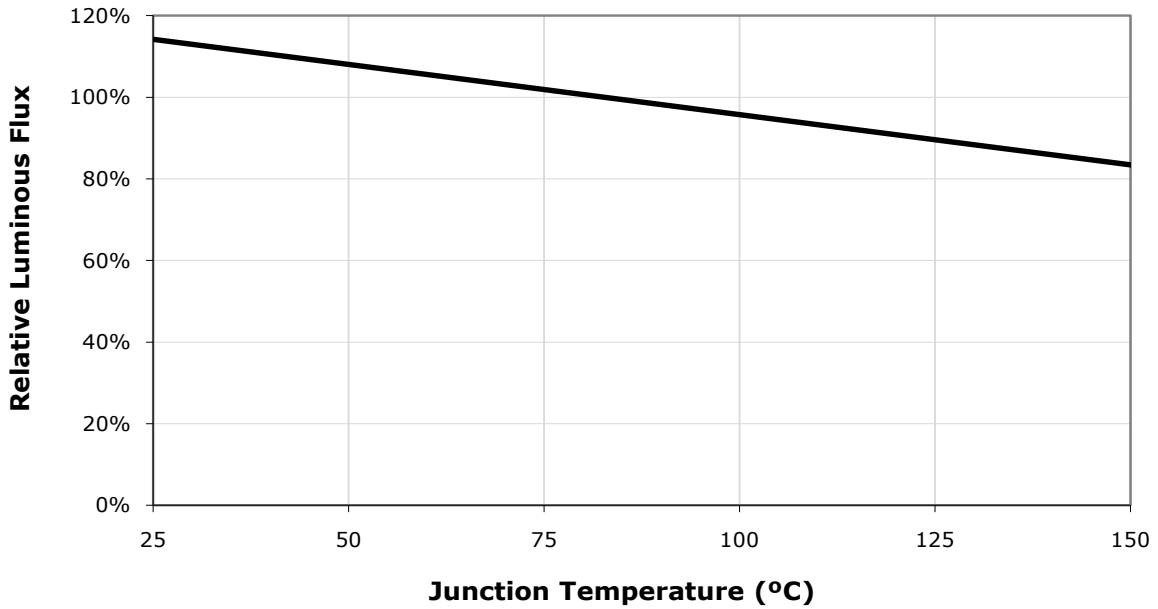

RELATIVE RADIANT FLUX VS. JUNCTION TEMPERATURE ($I_F = 350$ mA) - ROYAL BLUE

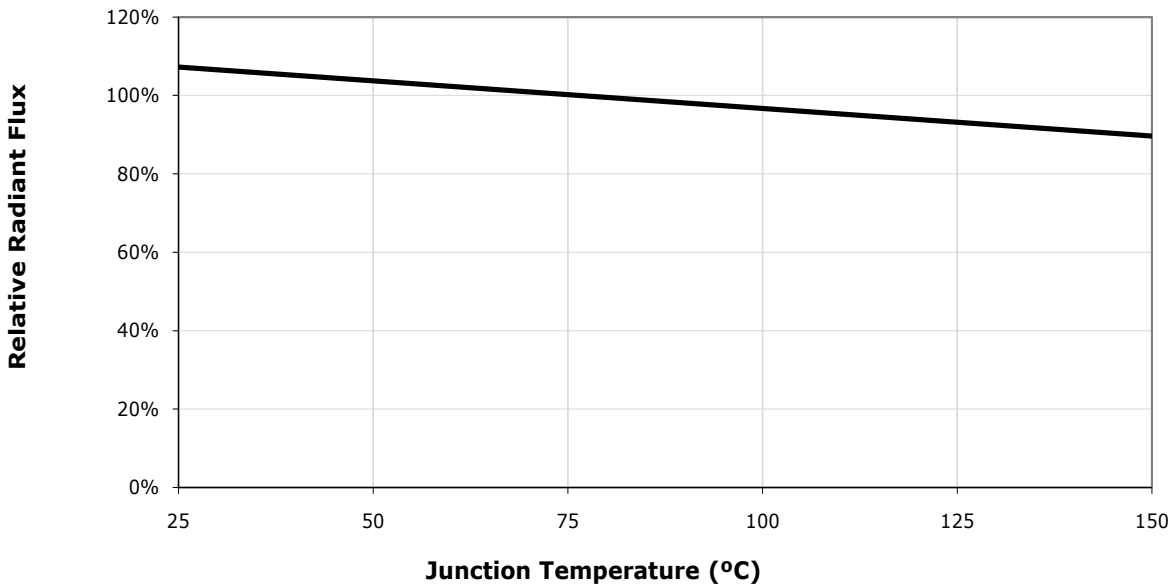

ELECTRICAL CHARACTERISTICS ($T_j = 85\text{ }^\circ\text{C}$)

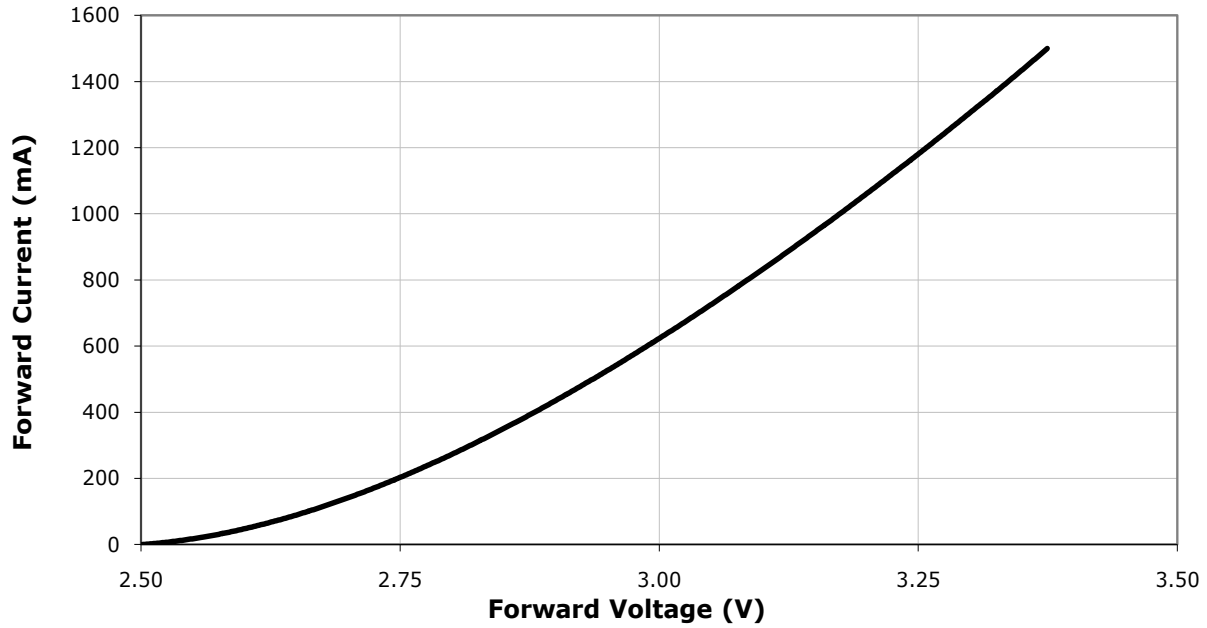

RELATIVE LUMINOUS FLUX VS. CURRENT ($T_j = 85\text{ }^\circ\text{C}$) - WHITE

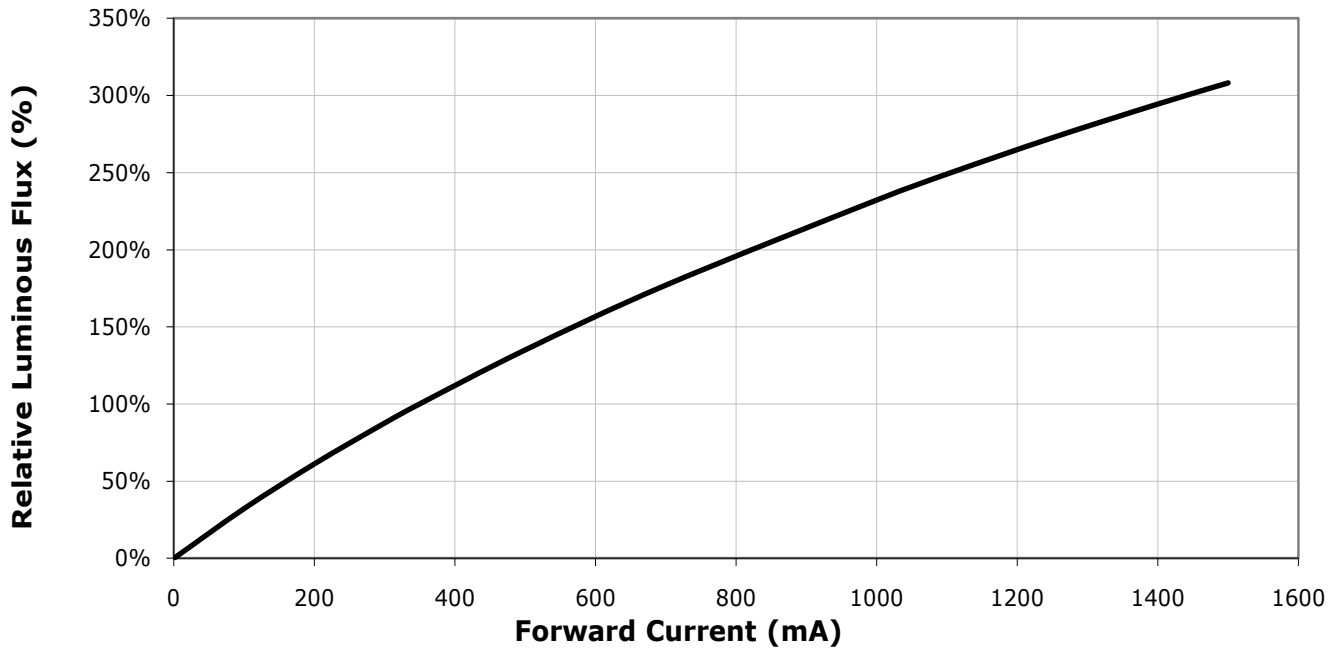

RELATIVE RADIANT FLUX VS. CURRENT ($T_j = 85\text{ }^\circ\text{C}$) - ROYAL BLUE

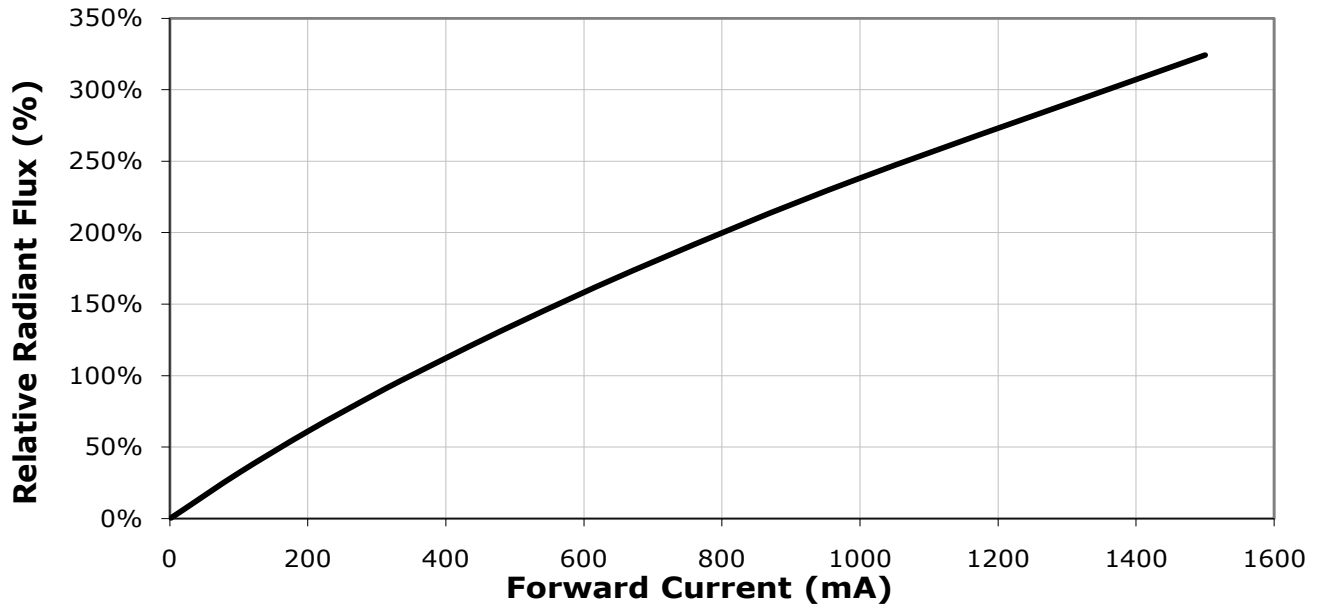

RELATIVE CHROMATICITY VS. CURRENT AND TEMPERATURE (WARM WHITE)

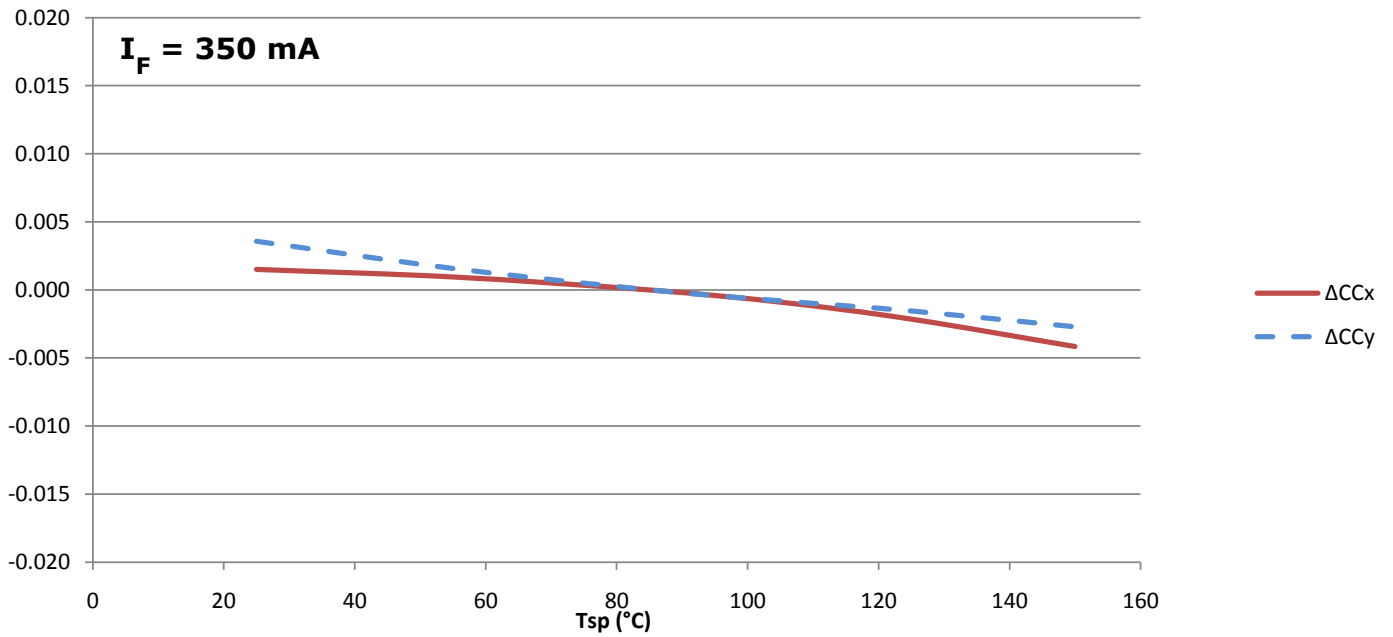
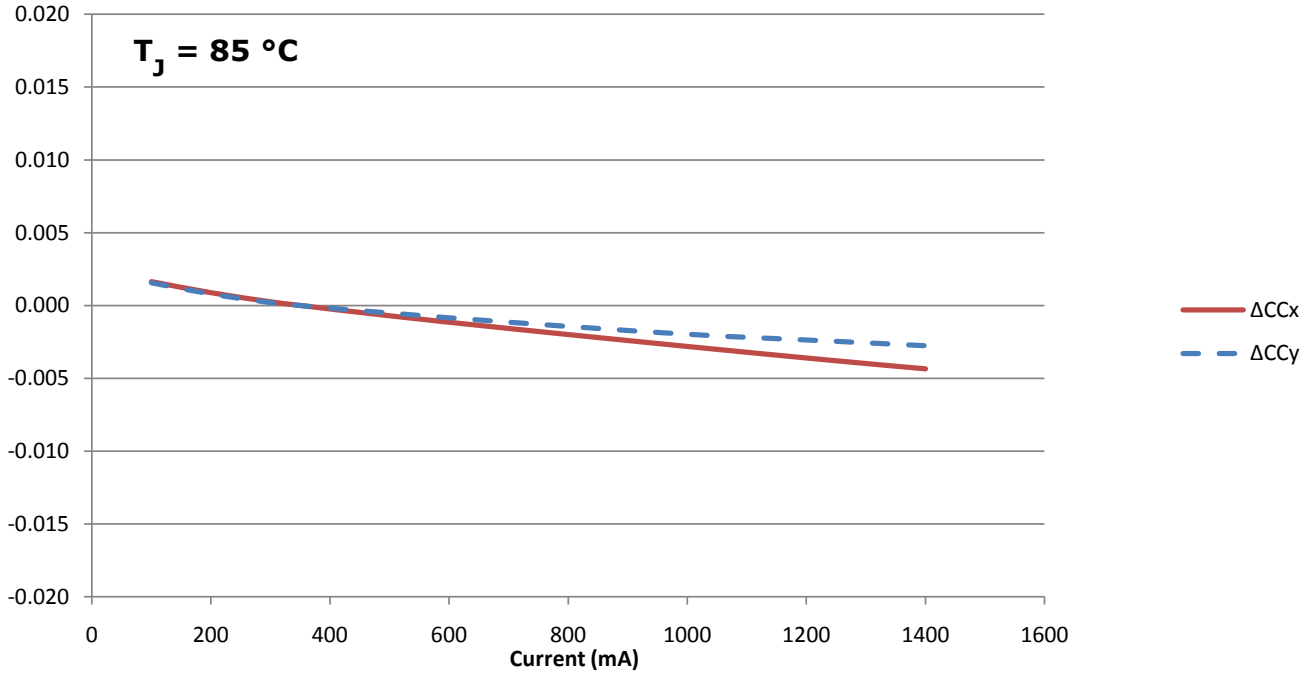

TYPICAL SPATIAL DISTRIBUTION - WHITE

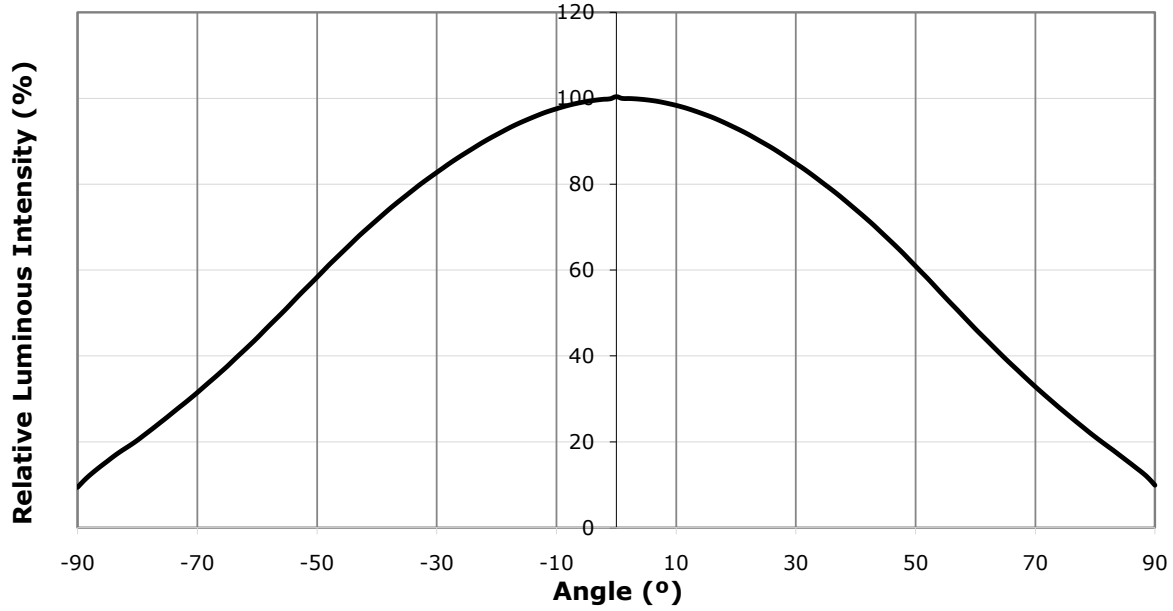

TYPICAL SPATIAL DISTRIBUTION - ROYAL BLUE

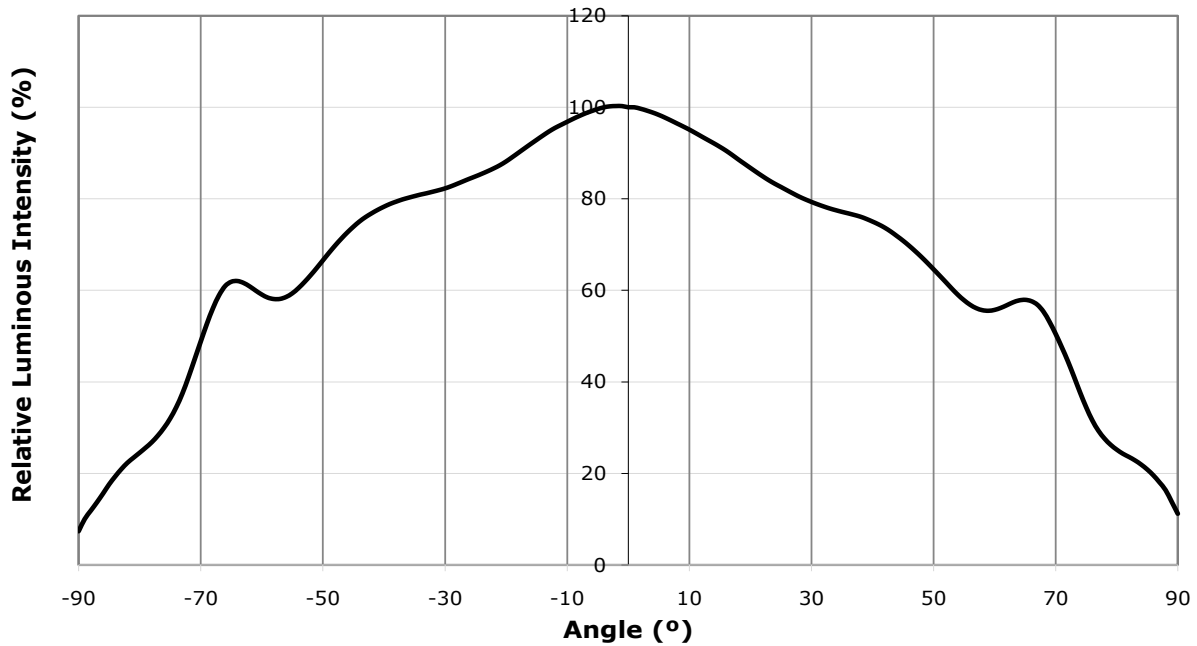

THERMAL DESIGN

The maximum forward current is determined by the thermal resistance between the LED junction and ambient. It is crucial for the end product to be designed in a manner that minimizes the thermal resistance from the solder point to ambient in order to optimize lamp life and optical characteristics.

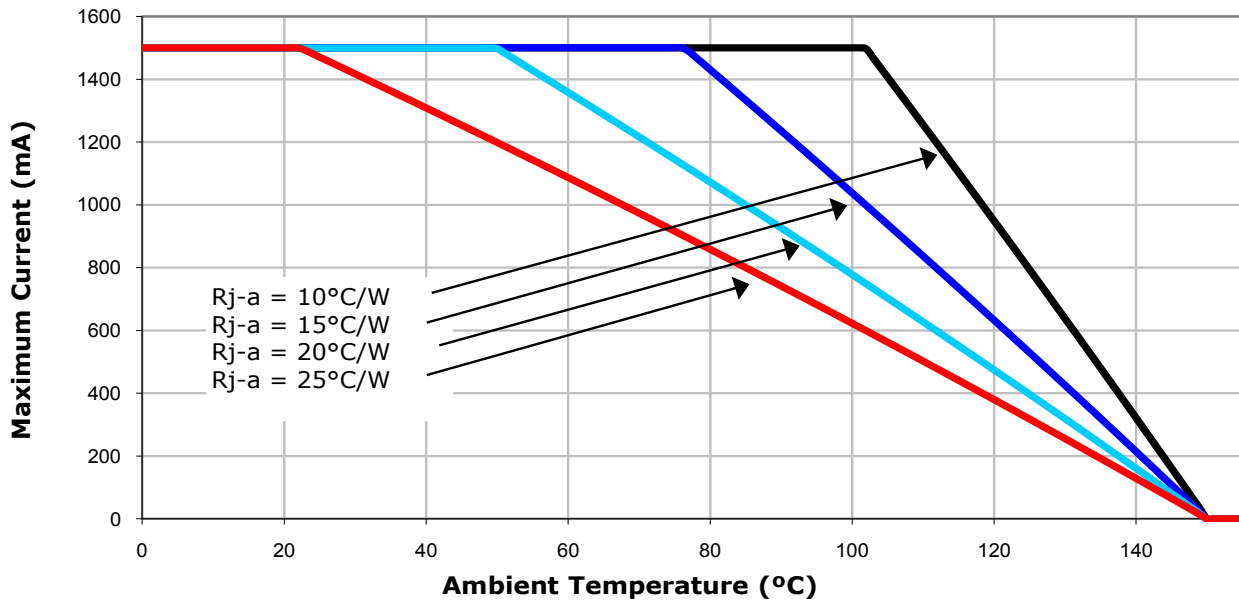

REFLOW SOLDERING CHARACTERISTICS

In testing, Cree has found XLamp XT-E LEDs to be compatible with JEDEC J-STD-020C, using the parameters listed below. As a general guideline, Cree recommends that users follow the recommended soldering profile provided by the manufacturer of solder paste used.

Note that this general guideline may not apply to all PCB designs and configurations of reflow soldering equipment.

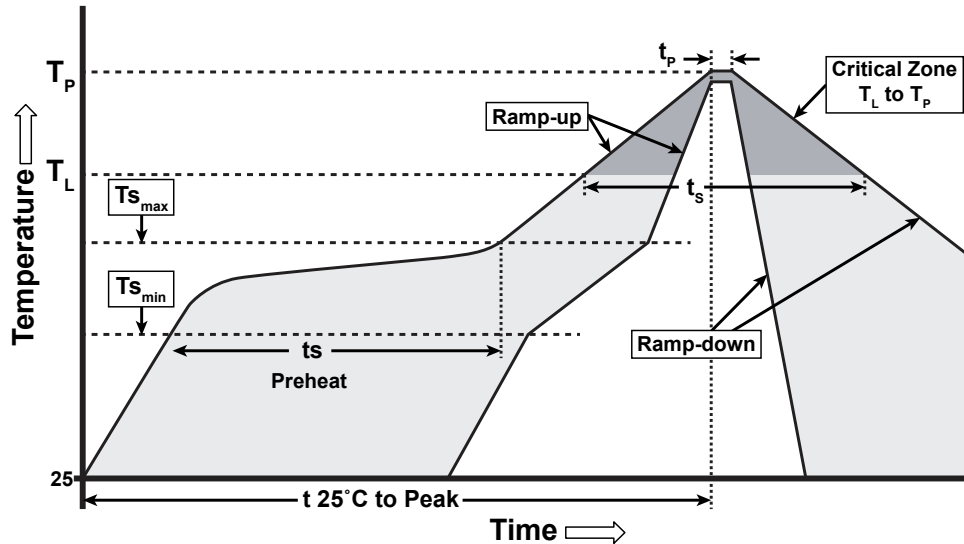

IPC/JEDEC J-STD-020C

| Profile Feature | Lead-Based Solder | Lead-Free Solder |
|---|-------------------|------------------|
| Average Ramp-Up Rate ($T_{s_{max}}$ to T_p) | 3 °C/second max. | 3 °C/second max. |
| Preheat: Temperature Min ($T_{s_{min}}$) | 100 °C | 150 °C |
| Preheat: Temperature Max ($T_{s_{max}}$) | 150 °C | 200 °C |
| Preheat: Time ($t_{s_{min}}$ to $t_{s_{max}}$) | 60-120 seconds | 60-180 seconds |
| Time Maintained Above: Temperature (T_L) | 183 °C | 217 °C |
| Time Maintained Above: Time (t_L) | 60-150 seconds | 60-150 seconds |
| Peak/Classification Temperature (T_p) | 215 °C | 260 °C |
| Time Within 5 °C of Actual Peak Temperature (t_p) | 10-30 seconds | 20-40 seconds |
| Ramp-Down Rate | 6 °C/second max. | 6 °C/second max. |
| Time 25 °C to Peak Temperature | 6 minutes max. | 8 minutes max. |

Note: All temperatures refer to the topside of the package, measured on the package body surface.

NOTES

Lumen Maintenance Projections

Cree now uses standardized IES LM-80-08 and TM-21-11 methods for collecting long-term data and extrapolating LED lumen maintenance. For information on the specific LM-80 data sets available for this LED, refer to the public LM-80 results document at www.cree.com/xlamp_app_notes/LM80_results.

Please read the XLamp Long-Term Lumen Maintenance application note at www.cree.com/xlamp_app_notes/lumen_maintenance for more details on Cree's lumen maintenance testing and forecasting. Please read the XLamp Thermal Management application note at www.cree.com/xlamp_app_notes/thermal_management for details on how thermal design, ambient temperature, and drive current affect the LED junction temperature.

Moisture Sensitivity

In testing, Cree has found XLamp XT-E LEDs to have unlimited floor life in conditions ≤ 30 °C/85% relative humidity (RH). Moisture testing included a 168-hour soak at 85 °C/85% RH followed by 3 reflow cycles, with visual and electrical inspections at each stage.

Cree recommends keeping XLamp LEDs in their sealed moisture-barrier packaging until immediately prior to use. Cree also recommends returning any unused LEDs to the resealable moisture-barrier bag and closing the bag immediately after use.

RoHS Compliance

The levels of RoHS restricted materials in this product are below the maximum concentration values (also referred to as the threshold limits) permitted for such substances, or are used in an exempted application, in accordance with EU Directive 2011/65/EC (RoHS2), as amended through June 8, 2011. RoHS Declarations for this product can be obtained from your Cree representative or obtained from the Product Ecology section of www.cree.com.

REACH Compliance

REACH substances of high concern (SVHCs) information is available for this product. Since the European Chemical Agency (ECHA) has published notices of their intent to frequently revise the SVHC listing for the foreseeable future, please contact a Cree representative to insure you get the most up-to-date REACH Declaration. Historical REACH banned substance information (substances restricted or banned in the EU prior to 2010) is also available upon request.

UL Recognized Component

Level 4 enclosure consideration. The LED package or a portion thereof has been investigated as a fire and electrical enclosure per ANSI/UL 8750.

Vision Advisory Claim

WARNING: Do not look at an exposed lamp in operation. Eye injury can result. See LED Eye Safety at www.cree.com/xlamp_app_notes/led_eye_safety.

MECHANICAL DIMENSIONS

All measurements are $\pm .13$ mm unless otherwise indicated.

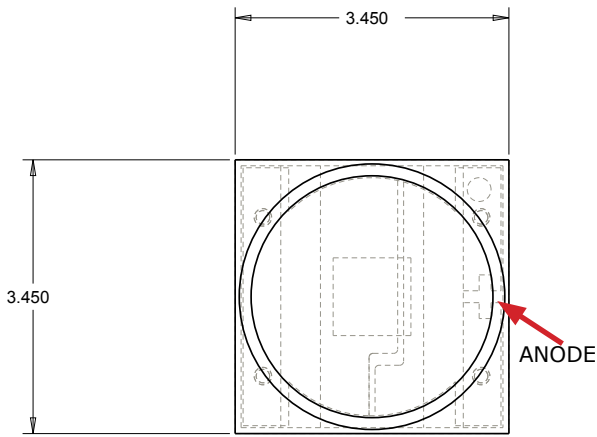
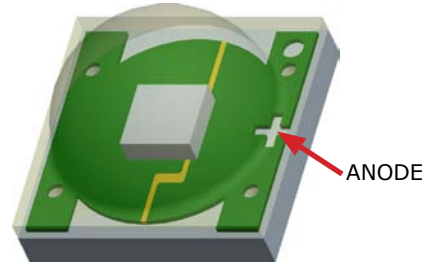

Top View

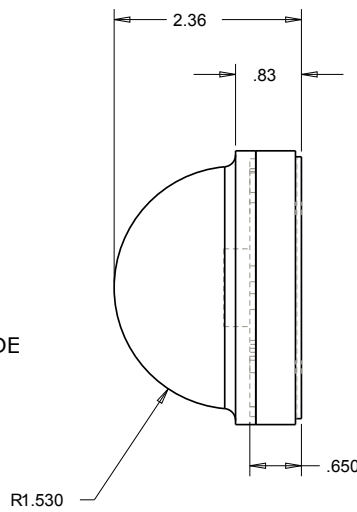

Side View

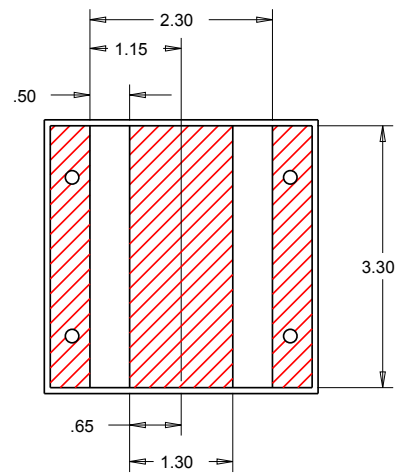

Bottom View

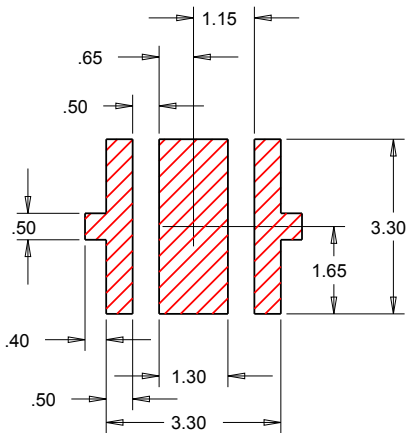

Recommended PCB Solder Pad

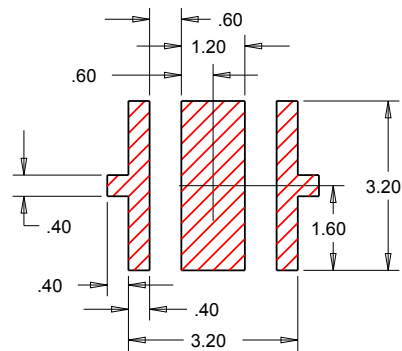

**Recommended Stencil Pattern
(Shaded Area Is Open)**

TAPE AND REEL

All Cree carrier tapes conform to EIA-481D, Automated Component Handling Systems Standard.

All dimensions in mm.

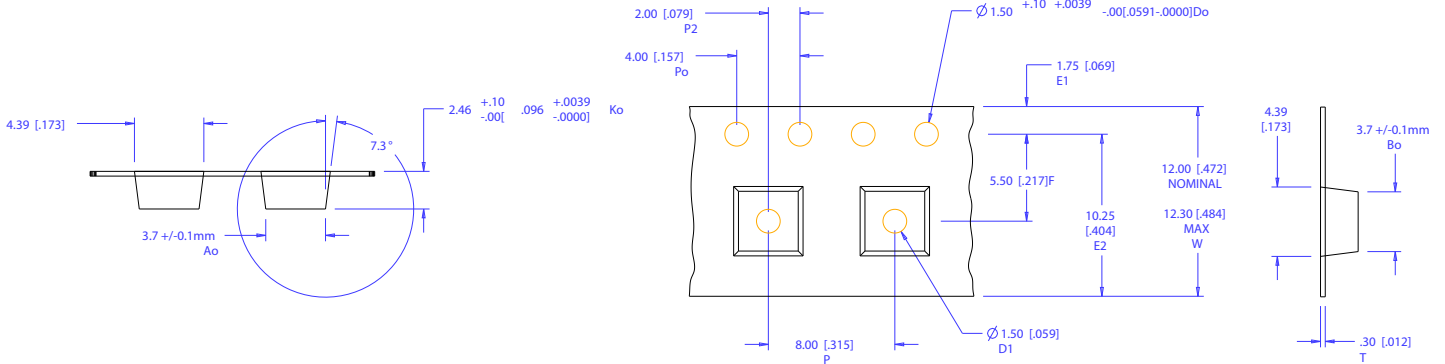

| POCKET SIZE | |
|-------------|------------------|
| Ao - | 3.7mm +/-0.1mm |
| Bo - | 3.7mm +/-0.1mm |
| Ko - | 2.46mm +0.1/-0mm |

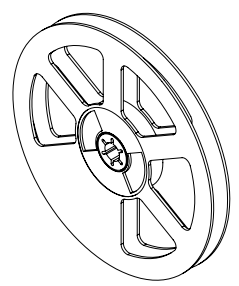
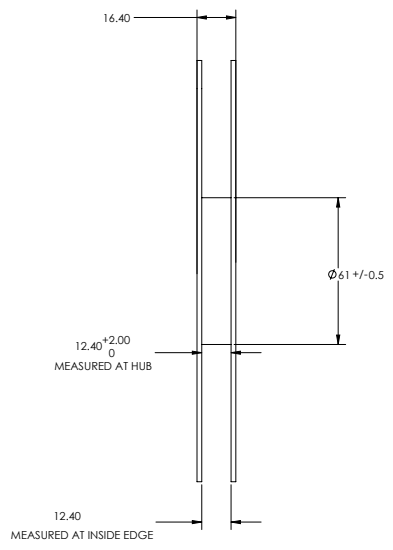
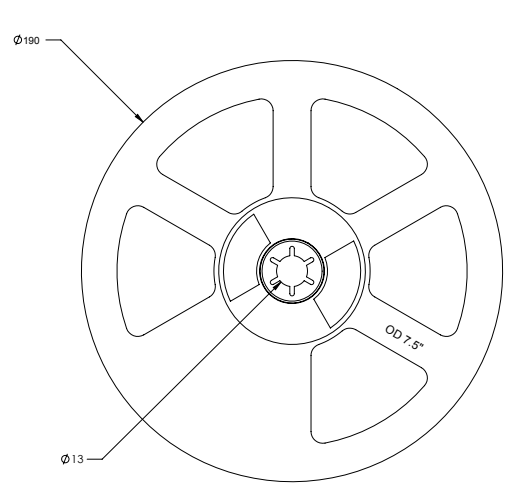
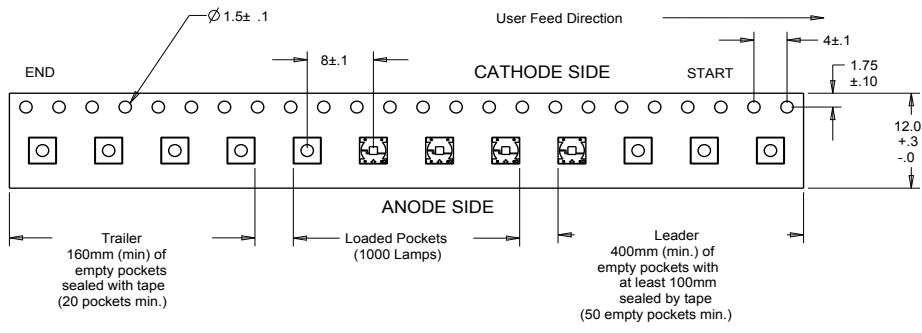

PACKAGING

Unpackaged Reel

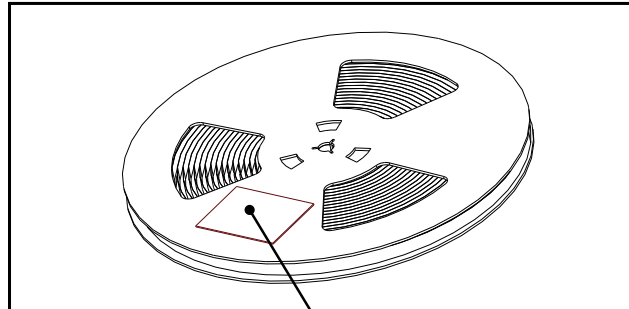

Label with Cree Bin Code, Qty, Reel ID

Packaged Reel

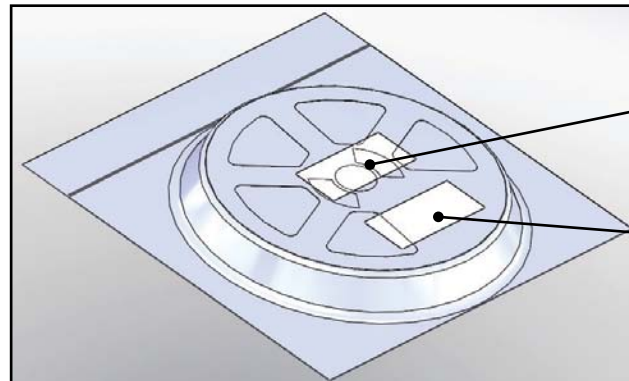

Label with Cree Order Code, Qty, Reel ID, PO #

Label with Cree Bin Code, Qty, Reel ID

Boxed Reel

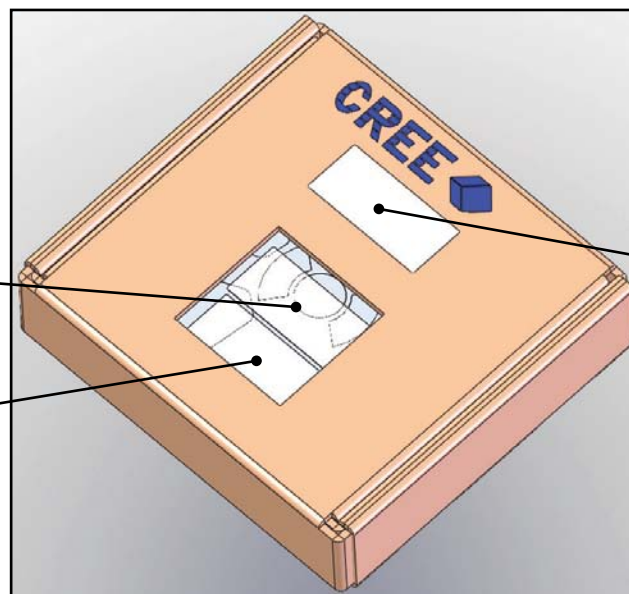

Label with Cree Order Code, Qty, Reel ID, PO #

Label with Cree Bin Code, Qty, Reel ID

Patent Label



Компания «ЭлектроПласт» предлагает заключение долгосрочных отношений при поставках импортных электронных компонентов на взаимовыгодных условиях!

Наши преимущества:

- Оперативные поставки широкого спектра электронных компонентов отечественного и импортного производства напрямую от производителей и с крупнейших мировых складов;
- Поставка более 17-ти миллионов наименований электронных компонентов;
- Поставка сложных, дефицитных, либо снятых с производства позиций;
- Оперативные сроки поставки под заказ (от 5 рабочих дней);
- Экспресс доставка в любую точку России;
- Техническая поддержка проекта, помощь в подборе аналогов, поставка прототипов;
- Система менеджмента качества сертифицирована по Международному стандарту ISO 9001;
- Лицензия ФСБ на осуществление работ с использованием сведений, составляющих государственную тайну;
- Поставка специализированных компонентов (Xilinx, Altera, Analog Devices, Intersil, Interpoint, Microsemi, Aeroflex, Peregrine, Syfer, Eurofarad, Texas Instrument, Miteq, Cobham, E2V, MA-COM, Hittite, Mini-Circuits, General Dynamics и др.);

Помимо этого, одним из направлений компании «ЭлектроПласт» является направление «Источники питания». Мы предлагаем Вам помощь Конструкторского отдела:

- Подбор оптимального решения, техническое обоснование при выборе компонента;
- Подбор аналогов;
- Консультации по применению компонента;
- Поставка образцов и прототипов;
- Техническая поддержка проекта;
- Защита от снятия компонента с производства.



Как с нами связаться

Телефон: 8 (812) 309 58 32 (многоканальный)

Факс: 8 (812) 320-02-42

Электронная почта: org@eplast1.ru

Адрес: 198099, г. Санкт-Петербург, ул. Калинина, дом 2, корпус 4, литера А.