

# IMB-H810-i2-R11

microATX motherboard supports 22nm LGA1150 Intel® Core™ i7/i5/i3, Pentium®, Celeron® CPU per Intel® H81, DDR3, VGA, dual GbE, LPT, COM, SATA 6Gb/s, iRIS-2400

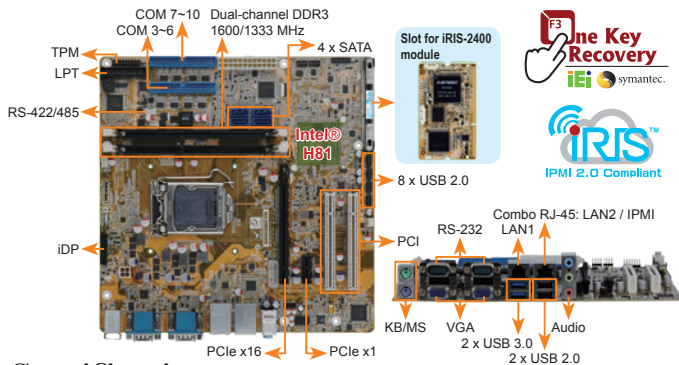

## Specifications

- ◆ CPU: LGA1150 Intel® Core™ i7/i5/i3, Pentium® or Celeron® processor supported
- ◆ Chipset: Intel® H81
- ◆ Memory: Two 240-pin 1600/1333 MHz dual-channel DDR3 & DDR3L SDRAM unbuffered DIMMs support up to 16 GB
- ◆ BIOS: UEFI BIOS
- ◆ Ethernet LAN1: Intel® I217LM with Intel® AMT9.0 support LAN2: Intel® I210-AT PCIe controller with NCSI support
- ◆ Graphics Engine Intel® HD Graphics Gen 7.5 supports DX11.1 and OpenCL 1.2, OpenGL 3.2 Full MPEG2, VC1, AVC Decode
- ◆ Display Output Dual independent display 2 x VGA (up to 1920x1200@60Hz) 1 x iDP interface for HDMI, LVDS, VGA, DVI, DP (up to 3840x2160@60Hz)
- ◆ Audio Realtek ALC662 HD Audio codec supports 5.1-channel 3 x Audio jacks (line-out, line-in, mic-in) on rear IO 1 x Front audio (2x5 pin)
- ◆ iRIS Remote Management Module 1 x iRIS-2400 slot
- ◆ TPM: 1 x TPM (2x10 pin)
- ◆ SMBus: 1 x SMBus (1x4 pin)
- ◆ iPC: 1 x iPC (1x4 pin)
- ◆ LAN LED: 2 x LAN LED (1x2 pin)
- ◆ External I/O Interface 1 x KB/MS 2 x USB 2.0 2 x RS-232 2 x USB 3.0
- ◆ Internal I/O Interface 1 x LPT (2x13 pin, P=2.54) 1 x RS-422/485 (1x4 pin, P=2.0) 2 x SATA 3Gb/s x 8 x USB 2.0 (2x4 pin, P=2.54) 2 x SATA 6Gb/s 8 x RS-232 (2x20 pin, P=2.54)
- ◆ Front Panel: 1 x Front panel (2x7 pin, power LED, HDD LED, speaker, power button, reset button)
- ◆ Expansion 1 x PCIe x16 slot (Gen 3) 1 x PCIe x1 slot 2 x PCI slot
- ◆ Watchdog Timer: Software programmable, supportS 1~255 sec system reset
- ◆ Fan Connector 1 x CPU smart fan (1x4 pin) 1 x System smart fan (1x3 pin)
- ◆ Power Supply: ATX power supply
- ◆ Power Consumption 3.3V@0.64A, 5V@4.20A, 12V@0.14A, Vcore\_12V@3.88A, 5VSB@0.20A (Intel® Core™ i7-4770K 3.90 GHz CPU with 8 GB (two 4 GB) 1333 MHz DDR3 memory)
- ◆ Operating Temperature: -20°C ~ 60°C
- ◆ Storage Temperature: -30°C ~ 70°C
- ◆ Operating Humidity: 5% ~ 95%, non-condensing
- ◆ Dimensions: 244mm x 244mm
- ◆ Weight: GW: 1200g / NW: 680g
- ◆ CE/FCC compliant

## Packing List

1 x IMB-H810-i2 single board computer	2 x SATA cable
1 x I/O shielding	1 x QIG

## Ordering Information

Part No.	Description
IMB-H810-i2-R11	microATX motherboard supports 22nm LGA1150 Intel® Core™ i7/i5/i3/Pentium® and Celeron® CPU per Intel® H81, DDR3, VGA, Dual Intel® PCIe GbE, USB 2.0, PCI, COM, SATA 6Gb/s, LPT, HD Audio, iRIS-2400 and RoHS
IMB-H810-ECO-R11	LGA1150 Intel® Core™ i7/i5/i3, Pentium® and Celeron® CPU per Intel® H81, DDR3, VGA, Dual PCIe GbE, USB 2.0, COM, LPT, SATA 6Gb/s, HD Audio, ECO packing, RoHS (10 pce/pack)
iRIS-2400-R10	IPMI 2.0 adapter card with AST2400 BMC chip for DDR3 SO-DIMM socket interface
19800-000049-RS	LPT flat cable, 240mm, P=2.54
19800-000075-RS	PS/2 KB/MS cable with bracket, 220mm, P=2.0
19800-003100-100-RS	Dual port USB cable with bracket, 30mm, P=2.54
19800-010500-200-RS	USB 3.0 cable with bracket, 450mm
32102-000100-200-RS	SATA power cable, MOLEX 5264-4P to SATA15P
32205-001203-200-RS	RS-232 cable, 40-pin to four DB-9, 400mm, P=2.54
32205-003801-100-RS	RS-232/422/485, RS-422/485 cable, 500mm
CF-115XA-R10	High performance LGA1155/LGA1156 cooler kit, 1U chassis compatible, 73W
CF-115XE-R10	High performance LGA1155/LGA1156 cooler kit, 95W
DP-DP-R10	DisplayPort to DisplayPort converter board (for IEI iDP connector)
DP-DVI-R10	DisplayPort to DVI-D converter board (for IEI iDP connector)
DP-HDMI-R10	DisplayPort to HDMI converter board (for IEI iDP connector)
DP-LVDS-R10	DisplayPort to 24-bit dual-channel LVDS converter board (for IEI iDP connector)
DP-VGA-R10	DisplayPort to VGA converter board (for IEI iDP connector)
TPM-IN01-R20	20-pin Infineon TPM module, software management tool, firmware v3.17

# IMB-Q770

microATX motherboard supports 22nm LGA1155 Intel® Core™ i7/i5/i3 CPU with Intel® Q77, DDR3, triple independent display via Dual HDMI/DVI-I, dual Intel® PCIe GbE, USB 3.0, SATA 6Gb/s, ten serial ports, HD Audio and RoHS

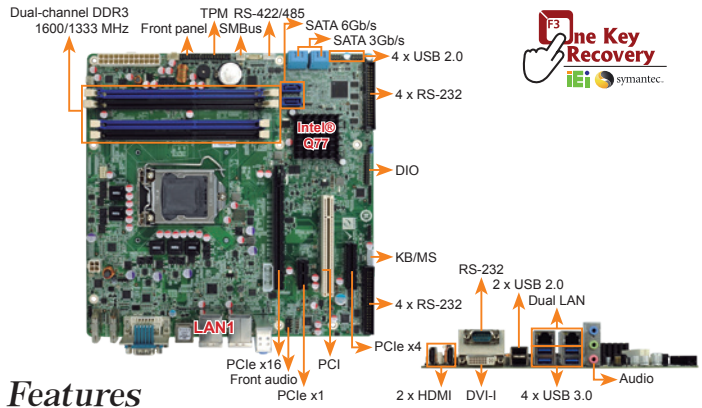

## Features

- LGA1155 Intel® Core™ i7/i5/i3 processor supported
- Dual-channel DDR3 1600/1333 MHz supports up to 32 GB
- Intel® PCIe GbE with Intel® AMT 8.0 supported
- Supports 3 displays with 2 displays in combination of HDMI, DVI and VGA
- Supports PCI Express generation 3.0 at 8GT/s I/O bandwidth
- USB 3.0 and SATA 6Gb/s supported
- Supports multiple scalable serial ports
- IEI One Key Recovery solution allows you to create rapid OS backup and recovery

## Specifications

- ◆ CPU: LGA1155 socket supports Intel® Core™ i7/ i5/i3 quad/dual core processor
- ◆ Chipset: Intel® Q77
- ◆ Memory Four 240-pin 1600/1333 MHz dual-channel DDR3 SDRAM unbuffered DIMMs support up to 32GB
- ◆ BIOS: UEFI BIOS
- ◆ Ethernet LAN1: Intel® 82583V PCIe controller LAN2: Intel® 82579 PHY with Intel® AMT 8.0 support
- ◆ Graphics Engine Intel® HD Graphics Gen 7 supports DX11 and OpenCL 1.1 Full MPEG2, VC1, AVC Decode
- ◆ Display Output Triple independent display 2 x HDMI (up to 1920x1200@60Hz) 1 x DVI-I (up to 1920x1200@60Hz)
- ◆ Audio Realtek ALC662 HD Audio codec supports 5.1-channel 3 x Audio jacks (line-out, line-in, mic-in) on rear IO 1 x Front audio (2x5 pin)
- ◆ Front Panel: 1 x Front panel (2x7 pin, power LED, HDD LED, speaker, power button, reset button)
- ◆ TPM: 1 x TPM (2x10 pin)
- ◆ SMBus: 1 x SMBus (1x4 pin)
- ◆ iPC: 1 x iPC (1x4 pin)
- ◆ Infrared Interface: 1 x Infrared Interface (1x5 pin)
- ◆ External I/O Interface 1 x RS-232 2 x USB 2.0 4 x USB 3.0
- ◆ Internal I/O Interface 1 x KB/MS (1x6 pin) 1 x RS-422/485 (1x4 pin, P=2.0) 2 x SATA 3Gb/s (RAID 0/1/5/10 supported) 2 x SATA 6Gb/s (RAID 0/1/5/10 supported) 4 x USB 2.0 (2x4 pin, P=2.54) 8 x RS-232 (2x20 pin, p=2.54)
- ◆ Expansion 1 x PCIe x16 slot 1 x PCIe x1 slot 1 x PCI slot
- ◆ Watchdog Timer: Software programmable supports 1~255 sec. system reset
- ◆ Digital I/O: 24-bit digital I/O (2x13 pin)
- ◆ Fan Connector 1 x CPU smart fan (1x4 pin) 1 x System smart fan (1x3 pin)
- ◆ Power Supply: ATX power supply 3.3V@0.31A, 5V@2.91A, 12V@0.51A, 12V@2.12A, -12V@0.10A (Intel® Core™ i3 3200 3.2GHz CPU with four 1333 MHz 1 GB DDR3 memory)
- ◆ Operating Temperature: -10°C ~ 60°C
- ◆ Storage Temperature: -20°C ~ 70°C
- ◆ Operating Humidity 5% ~ 95%, non-condensing
- ◆ Dimensions: 244 mm x 244 mm
- ◆ Weight: GW: 1200g / NW: 700g
- ◆ CE/FCC compliant

## Packing List

1 x IMB-Q770 single board computer	4 x SATA cable
1 x DVI-I to VGA adapter	1 x Mini jumper pack
1 x I/O shielding	1 x QIG

## Ordering Information

Part No.	Description
IMB-Q770-R10	microATX motherboard supports 22nm LGA1155 Intel® Core™ i7/i5/i3 CPU with Intel® Q77, DDR3, three independent displays via dual HDMI/DVI-I, dual Intel® PCIe GbE, USB 3.0, ten serial ports, SATA 6Gb/s, HD Audio and RoHS
19800-000075-RS	PS/2 KB/MS cable with bracket, 220mm, P=2.0
19800-003100-300-RS	Dual port USB cable with bracket, 30mm, P=2.54
32102-000100-200-RS	SATA power cable, MOLEX 5264-4P to SATA15P
32205-001203-200-RS	RS-232 cable, 40-pin to four DB-9, 400mm, P=2.54
32205-003800-300-RS	422/485 cable, 200mm, P=2.0
CF-115XA-R10	High performance LGA1155/LGA1156 cooler kit, 1U chassis compatible, 73W
CF-1156C-R20	LGA1155/LGA1156 cooler kit, 1U chassis compatible, 45W
CF-1156D-R20	LGA1155/LGA1156 cooler kit, 1U chassis compatible, 65W
CF-115XE-R10	High performance LGA1155/LGA1156 cooler kit, 95W
TPM-IN01-R20	20-pin Infineon TPM module, software management tool, firmware v3.17



Компания «ЭлектроПласт» предлагает заключение долгосрочных отношений при поставках импортных электронных компонентов на взаимовыгодных условиях!

Наши преимущества:

- Оперативные поставки широкого спектра электронных компонентов отечественного и импортного производства напрямую от производителей и с крупнейших мировых складов;
- Поставка более 17-ти миллионов наименований электронных компонентов;
- Поставка сложных, дефицитных, либо снятых с производства позиций;
- Оперативные сроки поставки под заказ (от 5 рабочих дней);
- Экспресс доставка в любую точку России;
- Техническая поддержка проекта, помощь в подборе аналогов, поставка прототипов;
- Система менеджмента качества сертифицирована по Международному стандарту ISO 9001;
- Лицензия ФСБ на осуществление работ с использованием сведений, составляющих государственную тайну;
- Поставка специализированных компонентов (Xilinx, Altera, Analog Devices, Intersil, Interpoint, Microsemi, Aeroflex, Peregrine, Syfer, Eurofarad, Texas Instrument, Miteq, Cobham, E2V, MA-COM, Hittite, Mini-Circuits, General Dynamics и др.);

Помимо этого, одним из направлений компании «ЭлектроПласт» является направление «Источники питания». Мы предлагаем Вам помощь Конструкторского отдела:

- Подбор оптимального решения, техническое обоснование при выборе компонента;
- Подбор аналогов;
- Консультации по применению компонента;
- Поставка образцов и прототипов;
- Техническая поддержка проекта;
- Защита от снятия компонента с производства.



#### Как с нами связаться

**Телефон:** 8 (812) 309 58 32 (многоканальный)

**Факс:** 8 (812) 320-02-42

**Электронная почта:** [org@eplast1.ru](mailto:org@eplast1.ru)

**Адрес:** 198099, г. Санкт-Петербург, ул. Калинина, дом 2, корпус 4, литера А.