

The LB-603 FP series were designed to meet the need for multi-digit numeric displays. These LED numeric displays use GaAsP on GaP(red), GaP(green) for the emitting material and are housed in an epoxy resin package. They are three-digit displays with a character height of 14.3mm.

### ●Features

- 1) Height of character : 14.3mm.
- 2) The package surface is painted black and the segments are colored the display color.
- 3) High efficiency reflectors are used to achieve a bright, clear display.

### ●Dimensions (Unit : mm)

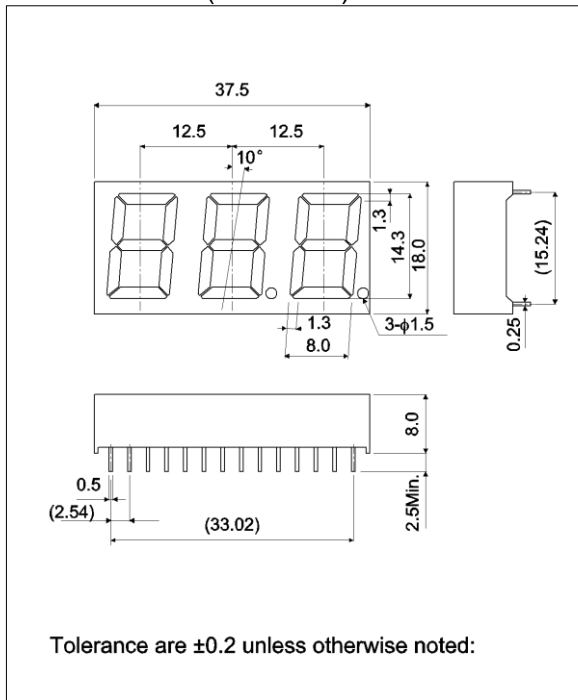

### ●Pin assignments

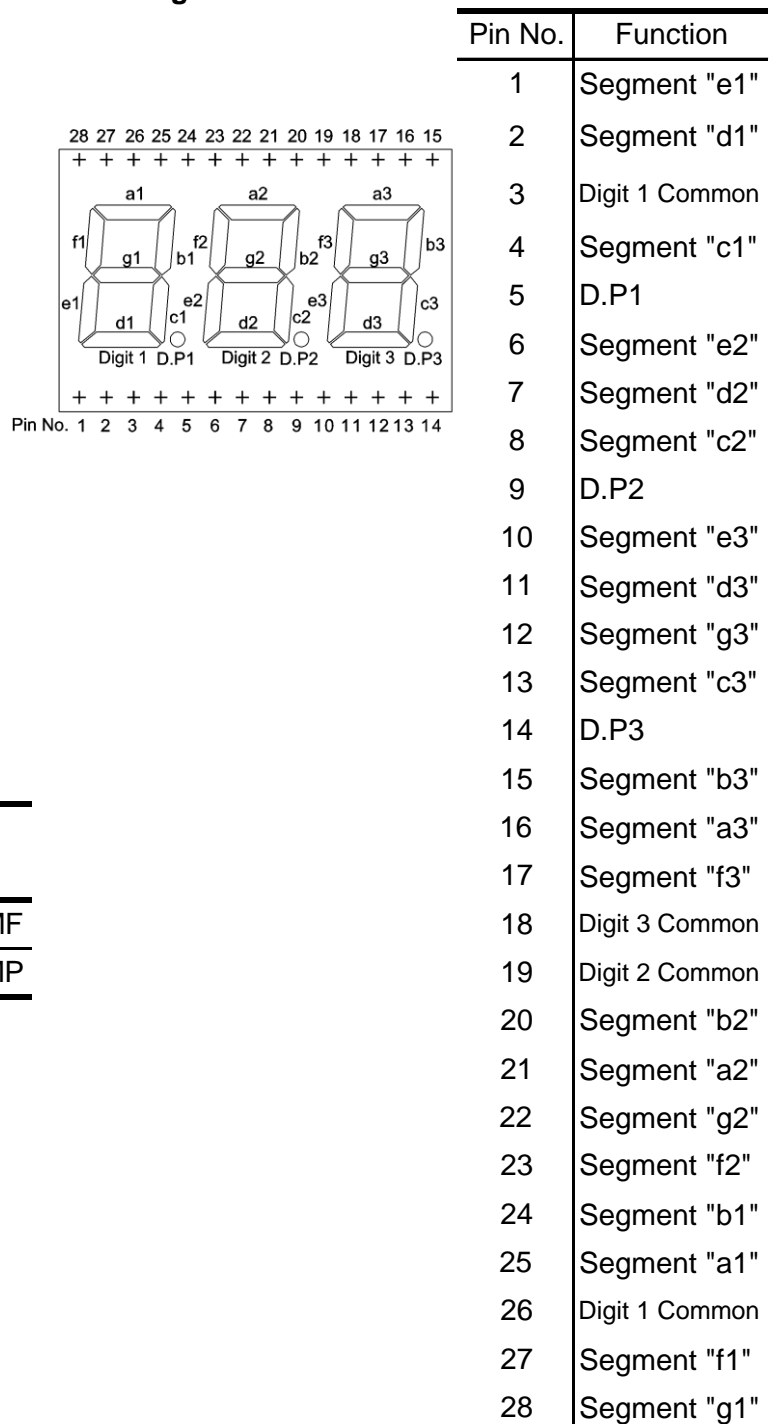

### ●Selection guide

Emitting color	Red	Green
	Common	
Anode	LB-603VF	LB-603MF
Cathode	LB-603VP	LB-603MP

●Internal circuit schematic

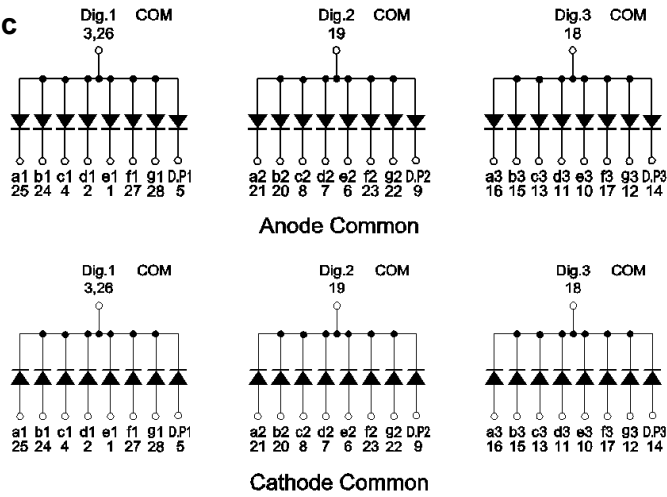

●Absolute maximum ratings (T<sub>a</sub> = 25°C)

Parameter	Symbol	Red	Green	Unit
		LB-603VF / VP	LB-603MF / MP	
Power dissipation	P <sub>D</sub>	960	1440	mW
Power dissipation	P <sub>D</sub> / seg	40	60	mW
Forward current	I <sub>F</sub>	15	20	mA
Peak forward current	I <sub>FP</sub>	60 *	60 *	mA
Reverse voltage	V <sub>R</sub>	5	5	V
Operating temperature	T <sub>opr</sub>	-25 to +75		°C
Storage temperature	T <sub>stg</sub>	-30 to +85		°C

\* Pulse width 1ms, duty 1 / 5

●Electrical and optical characteristics (T<sub>a</sub> = 25°C)

Parameter	Symbol	Conditions	Red			Green			Unit
			Min.	Typ.	Max.	Min.	Typ.	Max.	
Forward voltage	V <sub>F</sub>	I <sub>F</sub> =10mA	-	2.0	2.8	-	2.1	2.8	V
Reverse current	I <sub>R</sub>	V <sub>R</sub> =3V	-	-	100	-	-	100	μA
Peak wavelength	λ <sub>p</sub>	I <sub>F</sub> =10mA	-	650	-	-	563	-	nm
Spectral line halfwidth	Δλ	I <sub>F</sub> =10mA	-	40	-	-	40	-	nm

⊙ Not designed for radiation resistance.

●Luminous intensity

Parameter	λ <sub>p</sub>	Type	Min.	Typ.	Max.	Unit
Red	650	LB-603VF	5.6	16	-	mcd
		LB-603VP				
Green	563	LB-603MF	9	25	-	mcd
		LB-603MP				

⊙ Condition I<sub>F</sub>=10mA

●Electrical and optical characteristics curves

Fig.1 Forward Current vs. Forward Voltage

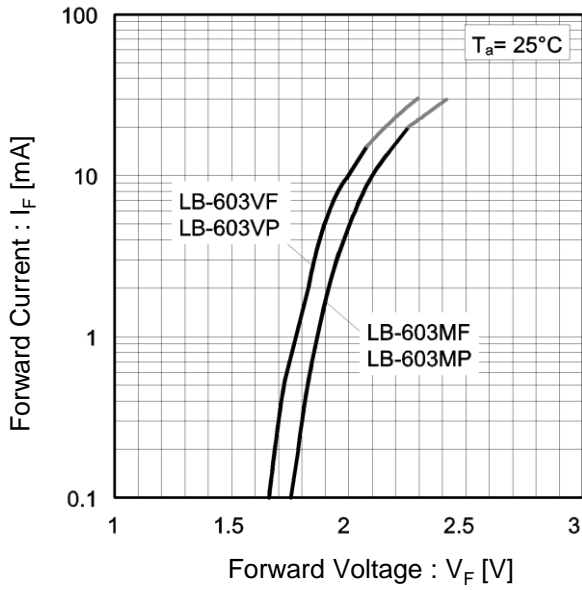

Fig.2 Relative Luminous Intensity vs. Forward Current

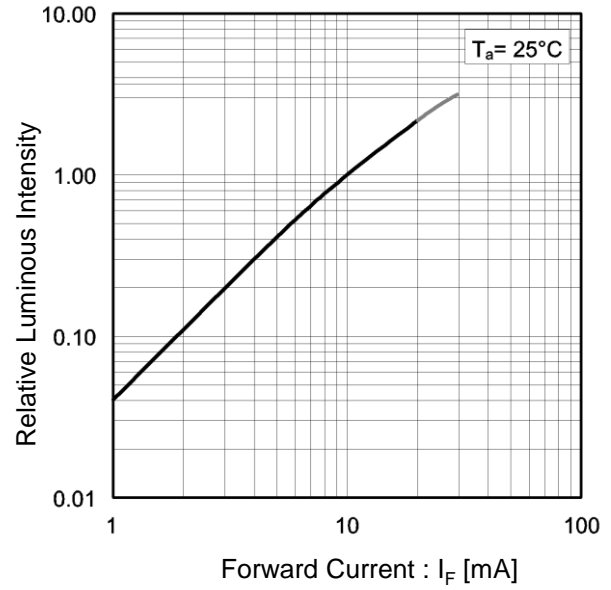

Fig.3 Relative Luminous Intensity vs. Case Temperature

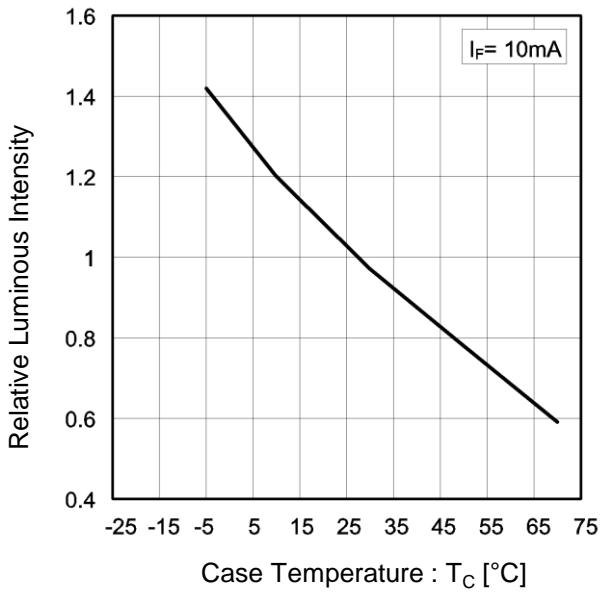
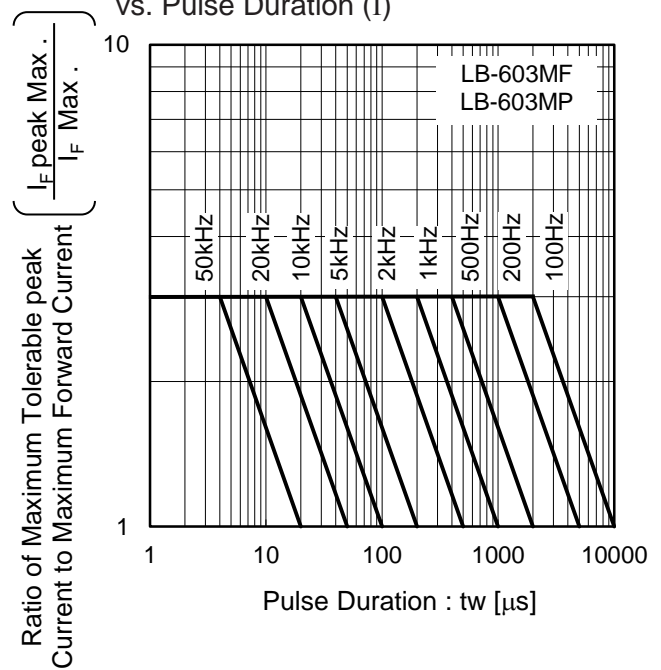

Fig.4 Ratio of Maximum Tolerable Peak Current vs. Pulse Duration (I)



●Electrical and optical characteristics curves

Fig.5 Ratio of Maximum Tolerable Peak Current vs. Pulse Duration (II)

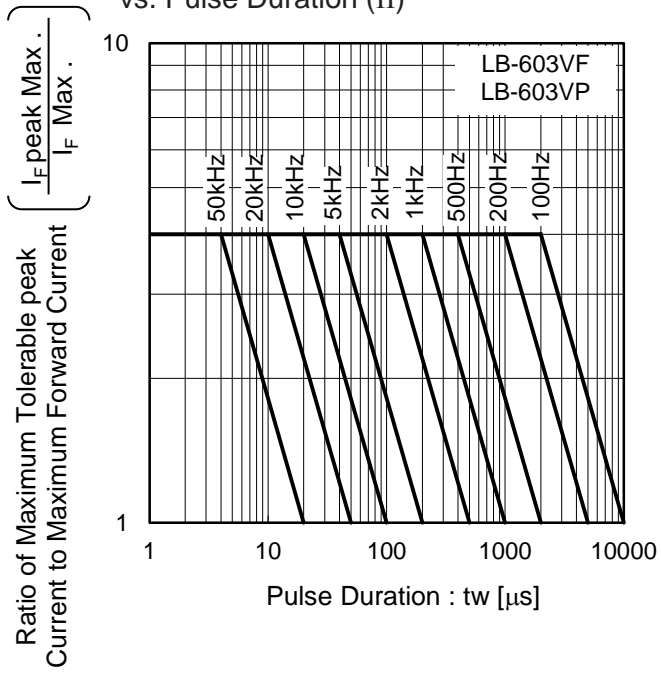
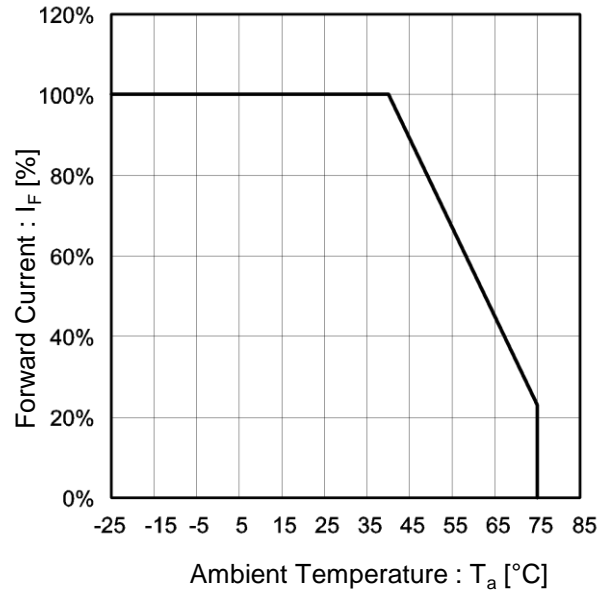

Fig.6 Derating



## Notes

- 1) The information contained herein is subject to change without notice.
- 2) Before you use our Products, please contact our sales representative and verify the latest specifications :
- 3) Although ROHM is continuously working to improve product reliability and quality, semiconductors can break down and malfunction due to various factors.  
Therefore, in order to prevent personal injury or fire arising from failure, please take safety measures such as complying with the derating characteristics, implementing redundant and fire prevention designs, and utilizing backups and fail-safe procedures. ROHM shall have no responsibility for any damages arising out of the use of our Products beyond the rating specified by ROHM.
- 4) Examples of application circuits, circuit constants and any other information contained herein are provided only to illustrate the standard usage and operations of the Products. The peripheral conditions must be taken into account when designing circuits for mass production.
- 5) The technical information specified herein is intended only to show the typical functions of and examples of application circuits for the Products. ROHM does not grant you, explicitly or implicitly, any license to use or exercise intellectual property or other rights held by ROHM or any other parties. ROHM shall have no responsibility whatsoever for any dispute arising out of the use of such technical information.
- 6) The Products are intended for use in general electronic equipment (i.e. AV/OA devices, communication, consumer systems, gaming/entertainment sets) as well as the applications indicated in this document.
- 7) The Products specified in this document are not designed to be radiation tolerant.
- 8) For use of our Products in applications requiring a high degree of reliability (as exemplified below), please contact and consult with a ROHM representative : transportation equipment (i.e. cars, ships, trains), primary communication equipment, traffic lights, fire/crime prevention, safety equipment, medical systems, servers, solar cells, and power transmission systems.
- 9) Do not use our Products in applications requiring extremely high reliability, such as aerospace equipment, nuclear power control systems, and submarine repeaters.
- 10) ROHM shall have no responsibility for any damages or injury arising from non-compliance with the recommended usage conditions and specifications contained herein.
- 11) ROHM has used reasonable care to ensure the accuracy of the information contained in this document. However, ROHM does not warrant that such information is error-free, and ROHM shall have no responsibility for any damages arising from any inaccuracy or misprint of such information.
- 12) Please use the Products in accordance with any applicable environmental laws and regulations, such as the RoHS Directive. For more details, including RoHS compatibility, please contact a ROHM sales office. ROHM shall have no responsibility for any damages or losses resulting from non-compliance with any applicable laws or regulations.
- 13) When providing our Products and technologies contained in this document to other countries, you must abide by the procedures and provisions stipulated in all applicable export laws and regulations, including without limitation the US Export Administration Regulations and the Foreign Exchange and Foreign Trade Act.
- 14) This document, in part or in whole, may not be reprinted or reproduced without prior consent of ROHM.



Thank you for your accessing to ROHM product informations.  
More detail product informations and catalogs are available, please contact us.

## ROHM Customer Support System

<http://www.rohm.com/contact/>

# Mouser Electronics

Authorized Distributor

Click to View Pricing, Inventory, Delivery & Lifecycle Information:

[ROHM Semiconductor:](#)

[LB-603MF](#) [LB-603MP](#)



Компания «ЭлектроПласт» предлагает заключение долгосрочных отношений при поставках импортных электронных компонентов на взаимовыгодных условиях!

Наши преимущества:

- Оперативные поставки широкого спектра электронных компонентов отечественного и импортного производства напрямую от производителей и с крупнейших мировых складов;
- Поставка более 17-ти миллионов наименований электронных компонентов;
- Поставка сложных, дефицитных, либо снятых с производства позиций;
- Оперативные сроки поставки под заказ (от 5 рабочих дней);
- Экспресс доставка в любую точку России;
- Техническая поддержка проекта, помощь в подборе аналогов, поставка прототипов;
- Система менеджмента качества сертифицирована по Международному стандарту ISO 9001;
- Лицензия ФСБ на осуществление работ с использованием сведений, составляющих государственную тайну;
- Поставка специализированных компонентов (Xilinx, Altera, Analog Devices, Intersil, Interpoint, Microsemi, Aeroflex, Peregrine, Syfer, Eurofarad, Texas Instrument, Miteq, Cobham, E2V, MA-COM, Hittite, Mini-Circuits, General Dynamics и др.);

Помимо этого, одним из направлений компании «ЭлектроПласт» является направление «Источники питания». Мы предлагаем Вам помощь Конструкторского отдела:

- Подбор оптимального решения, техническое обоснование при выборе компонента;
- Подбор аналогов;
- Консультации по применению компонента;
- Поставка образцов и прототипов;
- Техническая поддержка проекта;
- Защита от снятия компонента с производства.



#### Как с нами связаться

**Телефон:** 8 (812) 309 58 32 (многоканальный)

**Факс:** 8 (812) 320-02-42

**Электронная почта:** [org@eplast1.ru](mailto:org@eplast1.ru)

**Адрес:** 198099, г. Санкт-Петербург, ул. Калинина, дом 2, корпус 4, литера А.