

UPOS-211 Series

15" Ubiquitous POS Terminal
UPOS-211D with Intel® BayTrail J1900
UPOS-211F with Intel® Skylake Core i3 / i5 / Celeron



Features

- 15" TFT LCD (LED backlight) with 5 wire Resistive or PCAP Touch
- Built in Intel Baytrail J1900 or Skylake-U
- Stylish design with dual hinge, thinner boarder, slim screen
- Clear Cable Management
- Low power & fanless operation without heat ventilation holes
- Easy access to key components
- Easy peripheral mount design integrated
- Device Options: 2nd Display, MSR, VFD, RFID, Barcode Scanner



Introduction

UPOS-211 is an All-in-One POS System with 15" true-flat PCAP touch or 5 wire Resistive touch. It is with Intel Baytrail or Skylake-U processor, fanless design with quiet operation and energy saving. It features dual hinge design which provides the smallest footprint to save counter space and reduce shipment freight. It provides easy access to key components. UPOS-211 supports both Windows and Android OS, and the front panel is with IP65 design, supports water and dust resistance, specific designed for Mini market store, Food merchandise, Convenience store, Specialty store. UPOS-211 is with the most competitive cost, and energy effective platform built for retail and hospitality.

Features Highlight



Foldable design with dual hinge



Tilt motion, 0-90 °C Freestyle rotation

- 1xUSB port on backside w/ rubber cover
- Screwed bracket design for USB port to ensure data security (Optional)



Easy Access to USB Port



Wall Mount, via VESA mount kit

Specifications

Model	UPOS-211D	UPOS-211F
Processor	Intel Bay Trail Quad Core J1900, 2GHz up to 2.42GHz	Skylake-U, i5-6300U/CORE i3-6100U/Celeron 3955U
Memory	Up to 8GB DDR3L-1333	Up to 16GB SO-DDR4-2133
Storage	1 x 2.5" SATA HDD/SSD connector, SATA2 (3.0Gb/S)	1 x 2.5" SATA HDD/SSD connector, SATA3 (6.0Gb/S)
Panel	15" TFT LCD Display (1024 x 768), 250 cd/m ²	
Touch Screen	15", Analog Resistive 5-wires (Res. Flat Glass) / Projected Capacitive Touch Panel (PCAP. Flat Glass) Light Transmission: Res. Touch 80% +/-5% / Pcap Touch 85%+/-3%	
Bus Expansion	1 x Mini PCIe (for Wifi or 3G), shared with mini SATA connector	
Audio	1 x 2W speaker installed. 1 x Line out & 1 x Mic in (Optional)	
Power Supply	60W power adapter	
Serial Port	2 x COM RS232 ports on I/O board via RJ-48 connector, COM1 / COM2 support 5V & 12V by order Internal: 4 x COM port, COM3 for 5W Res. touch, COM4, COM5 support 5V & 12V by order, COM6 no power	
USB Port	External: 2 x USB2.0; 1 x USB3.0; Internal: 3 x USB2.0 (1x USB for PCAP touch)	External: 2 x USB3.0, 1 x USB2.0; Internal: 3 x USB2.0 (1 x USB for PCAP touch)
Ethernet	LAN controller: Realtek RTL8111G-CG, 1x RJ-45 Gigabit Ethernet	LAN controller: Intel WGI219LM, 1x RJ-45 Gigabit Ethernet
Display Output	1 x VGA, 1 x DP	
Cash Drawer	1 x RJ11, cash drawer, 24V default, 12V by order	
PS2	1 x PS2 (optional)	
Parallel Port	1 x LPT (optional)	
IP65	IP65 front panel protection	
Dimension (W x H x D)	354(W) x 327(H) x 237(D)mm, Stand: 237 x 200 mm	
Weight	5.2KG (Net weight) / 6.9KG (Gross weight)	
Operating Temp.	0 ~ 40° C	
Relative Humidity	10 ~ 90% @ 40° C	
Shock	10G peak acceleration (11ms duration)	
Vibration	5~500Hz 0.5Grms, random	
EMC / Safety	CE, CCC, UL, FCC, CB/LVD, VCCI, BSMI	
OS Support	POSReady 7, Windows 7 Pro, Windows 8.1 Pro (64-bit), Windows 10 IoT Enterprise, Linux Kernel 3.13 or above Android 4.4 (UPOS-211D series supports Android; UPOS-211F series does not support Android)	

Dimensions

Unit: mm

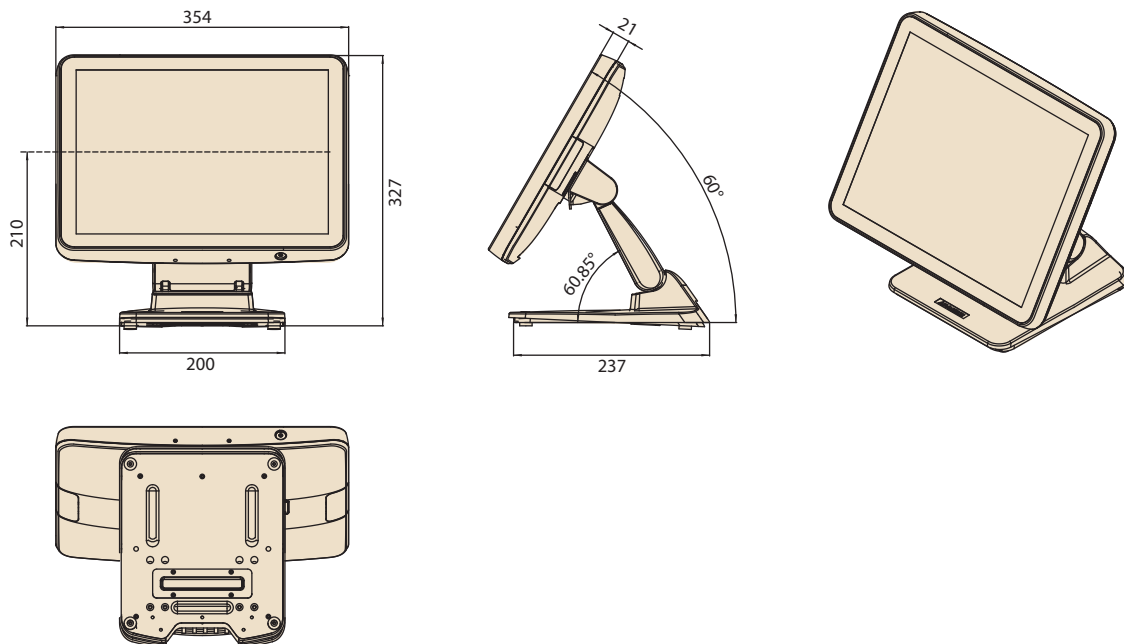

Ordering Information

Part No.	Description
UPOS-211DP-BST40	15",PCAP,J1900,4G RAM,4COM,5USB,W/Cable, Blk
UPOS-211DP-BST21	15",PCAP,J1900,4G,64G SSD,4COM,5USB,Blk
UPOS-211DR-BST21	15",Res,J1900,4G,64G SSD,4COM,5USB,Blk
UPOS-211DP-WST21	15",PCAP,J1900,4G,64G SSD,4COM,5USB,white
UPOS-211DP-BSTJ1	15",PCAP,J1900,4G,64G SSD,4COM,5USB,blk&org
UPOS-211FP-BST40	15",PCAP,i3-6100U,4G RAM,4COM,5USB,W/Cable,Blk
UPOS-211FP-BI520	15",PCAP,i5-6300U,4G,64G SSD,4COM,5USB,Blk

Installation Accessory

Part No.	Description
96CB-POWER-B-1.8M1	Power Cord (China) , 3P 1.8M, BK(CCC)
17AP164900518011	Power Cord CEE 7/16+C13 L1.8M (CE)
1700013977	Power Cord 10A 250V 3P 180/90 CCC 200cm (CCC)
1702002600	Power Cord 3P UL/CSA(USA) 125V 10A 1.83M 180D
1700020098	Power Cord 3P 10A 250V 183CM (Australian)
1702002605	Power Cord 2P FRANCE 10A/16A 220V 1.83M 90D (EU)
1700001714	Power Cord BSMI 3P 7A 125V 18AWG 180CM (BSMI)
1700000237	Power Cord 3P PSE 12A 125V 1.83M (Japan)
1700018704	Power Cord BSI 2P 10A 250V 180cm (UK)

POS Peripherals

Part No.	Description
UPOS-M07G-BST00	7" 2nd display, rear mount for UPOS-211,black(China only)
UPOS-M10G-BST00	10.1" 2nd display,no touch,rear mount for UPOS-211,blk
UPOS-P01-B110	VFD, rear mount for UPOS-211,black
UPOS-P03-B110	MSR,PS2 for UPOS-211,black
UPOS-P03-B112	MSR+ibutton for UPOS-211,black
UPOS-P03-B113	MSR+RFID for UPOS-211,black
UPOS-P03-B114	MSR+Fingerprint for UPOS-211,black
UPOS-P03-B115	MSR+IC card for UPOS-211,black
UPOS-P03-B116	RFID for UPOS-211,Left,black
1960080774N001	VESA BRACKET-1 FOR UPOS-211(Black)
1960080774N002	VESA BRACKET-1 FOR UPOS-211(WHITE)
1960078502N000	Wall MOUNT BRACKET FOR wall(should order together)
1960078503N000	Wall MOUNT BRACKET FOR unit(should order together)
2070014960	Image POSReady7 UPOS-211D V1.00 5MUI x64 Image
2070015279	WIN10 LTSB-6 UPOS-211D V1.00 7MUI x64 Wifi
1750006682-01	Wifi Antenna, should order 2pcs
EWM-W135F01E	Wifi Module,802.11 a/b/g/n,AR9382,Full size Mini PCIe
UPOS-P05-B110	2D Barcode scanner for UPOS-211,black
1750006682-01	Wifi Antenna, should order 2pcs
EWM-W157H01E	Half Size Mini PCIe,802.11 a/b/g/n/ac, Realtek RTL8821AE, 1T1R, w/ BT4.0 (Android 4.4 OS)
1960047454T000	Wifi bracket
20708WX6HS0002	Image WIN10 LTSB-6-U UPOS-211F(I5) V1.00 7MUI x64
20708AIONS0000	Image Android 444 UPOS-211D V0.9.4 64-bit
2070015299	UPOS-211D LUBuntu1604 x64 ENG OS V1.0.1

I/O Interface

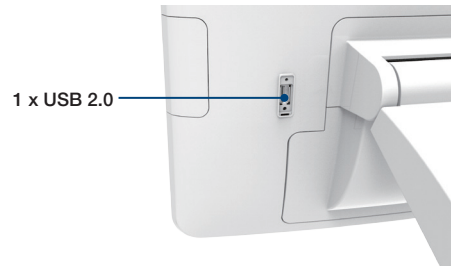

Option 1

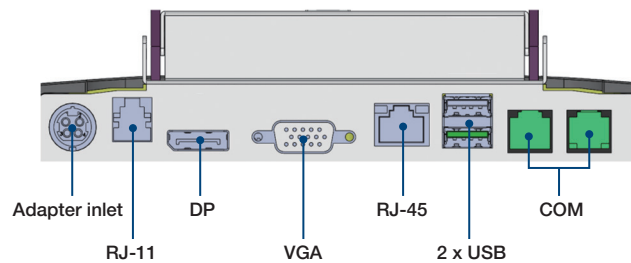

Option 2

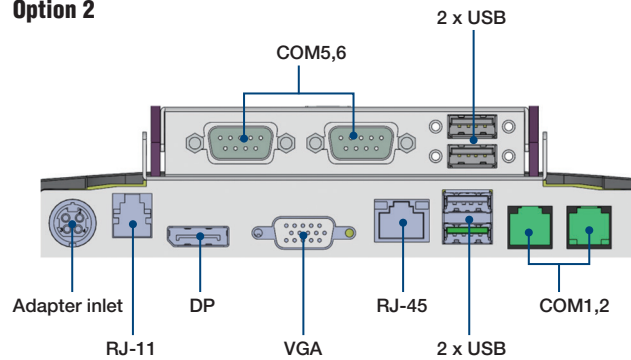

Option 3

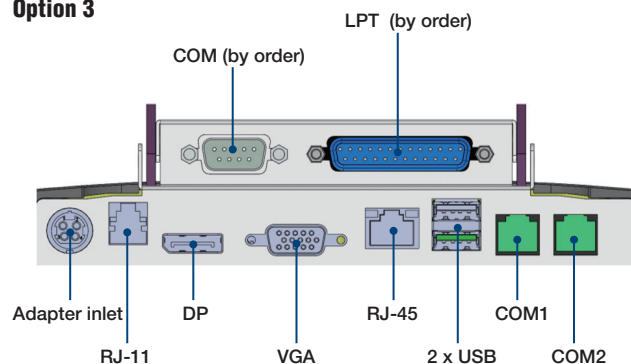



Компания «ЭлектроПласт» предлагает заключение долгосрочных отношений при поставках импортных электронных компонентов на взаимовыгодных условиях!

Наши преимущества:

- Оперативные поставки широкого спектра электронных компонентов отечественного и импортного производства напрямую от производителей и с крупнейших мировых складов;
- Поставка более 17-ти миллионов наименований электронных компонентов;
- Поставка сложных, дефицитных, либо снятых с производства позиций;
- Оперативные сроки поставки под заказ (от 5 рабочих дней);
- Экспресс доставка в любую точку России;
- Техническая поддержка проекта, помощь в подборе аналогов, поставка прототипов;
- Система менеджмента качества сертифицирована по Международному стандарту ISO 9001;
- Лицензия ФСБ на осуществление работ с использованием сведений, составляющих государственную тайну;
- Поставка специализированных компонентов (Xilinx, Altera, Analog Devices, Intersil, Interpoint, Microsemi, Aeroflex, Peregrine, Syfer, Eurofarad, Texas Instrument, Miteq, Cobham, E2V, MA-COM, Hittite, Mini-Circuits, General Dynamics и др.);

Помимо этого, одним из направлений компании «ЭлектроПласт» является направление «Источники питания». Мы предлагаем Вам помощь Конструкторского отдела:

- Подбор оптимального решения, техническое обоснование при выборе компонента;
- Подбор аналогов;
- Консультации по применению компонента;
- Поставка образцов и прототипов;
- Техническая поддержка проекта;
- Защита от снятия компонента с производства.



Как с нами связаться

Телефон: 8 (812) 309 58 32 (многоканальный)

Факс: 8 (812) 320-02-42

Электронная почта: org@eplast1.ru

Адрес: 198099, г. Санкт-Петербург, ул. Калинина, дом 2, корпус 4, литера А.