

General Description

The MAX44284 evaluation kit (EV kit) provides a proven design to evaluate the MAX44284 high-precision, low-power, current-sense amplifier. This EV kit demonstrates the MAX44284 in an ultra-small, 1.3mm x 0.9mm, 6-bump WLP package.

The EV kit PCB comes with a MAX44284HAWT+ installed, which is the 100V/V gain version. Other gain options are available. Contact the factory for the pin-compatible MAX44284FAWT+ (G = 50V/V), MAX44284WAWT+ (200V/V), and MAX44284EAWT+ (G = 500V/V).

EV Kit Contents

- MAX44284 EV Kit Board

Features and Benefits

- Precision Real-Time Current Monitoring
- -0.1V to +36V Input Common-Mode Range
- Proven PCB Layout
- Fully Assembled and Tested

[Ordering Information](#) appears at end of data sheet.

Quick Start

Required Equipment

The following items are required for operation:

- MAX44284 EV kit
- +3.3V, 1.5A DC power supply
- +2.7, 1A DC power supply
- An electronic load capable of sinking 1A (i.e., HP6060B)
- Two digital voltmeters

Procedure

The MAX44284 EV kit is fully assembled and tested. Follow the steps below to verify the board operation.

Caution: Do not turn on power supply or the electronic load until all connections are made.

- 1) Connect the positive terminal of the +3.3V supply to the VDD test point and the negative terminal of the supply to the nearest GND test point.
- 2) Connect the positive terminal of the +2.7V supply to the VBATT test point and the negative terminal of the supply to the nearest GND test point.
- 3) Set the electronic load to sink 650mA.
- 4) Connect the positive terminal of the electronic load to the LOAD test point and the negative terminal of the supply to the nearest GND test point.
- 5) Connect the first voltmeter between test points RS+ and RS- to measure V_{SENSE} .
- 6) Connect the second voltmeter between VOUT and the nearest GND test points.
- 7) Turn on the power supplies.
- 8) Enable the electronic load.
- 9) Verify that the first voltmeter displays 33mV and the second voltmeter displays 3.3V.

Detailed Description of Hardware

The MAX44284 EV kit provides a proven design to evaluate the MAX44284 high-side, current-sense amplifier, which offers precision accuracy specifications of input offset voltage (V_{OS}) less than $2\mu V$ (max) and gain error less than 0.05% (max).

Applying the V_{RS+} Supply and the Load

The EV kit is installed with a MAX44284H, which has a 100V/V gain. The current-sense resistors (R_{SENSE}) value is 0.05Ω with $\pm 0.5\%$ tolerance. The V_{OUT} for each channel given by:

$$V_{OUT} = I_{LOAD} \times R_{SENSE} \times A_V$$

where A_V is the gain and I_{LOAD} is the current load applied to the device. Normal operating V_{RS+} and V_{RS-} range is $-0.1V$ to $+36V$.

Measuring the Load Current

The load current is measured as a voltage drop (V_{SENSE}) across an external sense resistor. This voltage is then amplified by the current-sense amplifier and presented at

its $V_{OUT_}$ pin. Like all differential amplifiers, the output voltage has two components of error (an offset error and a gain error). The offset error affects accuracy at low currents and a gain error affects accuracy at large currents—both errors affect accuracy at intermediate currents. By minimizing both offset and gain errors, accuracy can be optimized over a wide dynamic range.

\overline{SHDN}

To place the device into shutdown mode, install a shunt in the 2-3 position on jumper JU1. See Table 1 for shunt positions.

Table 1. \overline{SHDN} Jumper Description (JU1)

JUMPER	SHUNT POSITION	DESCRIPTION
JU1	1-2*	Normal operation
	2-3	\overline{SHDN} , MAX44284 is in shutdown mode

*Default position.

Component List

Refer to file “max44284_evkit_reva_parts checklist.xls” attached to this PDF for component information.

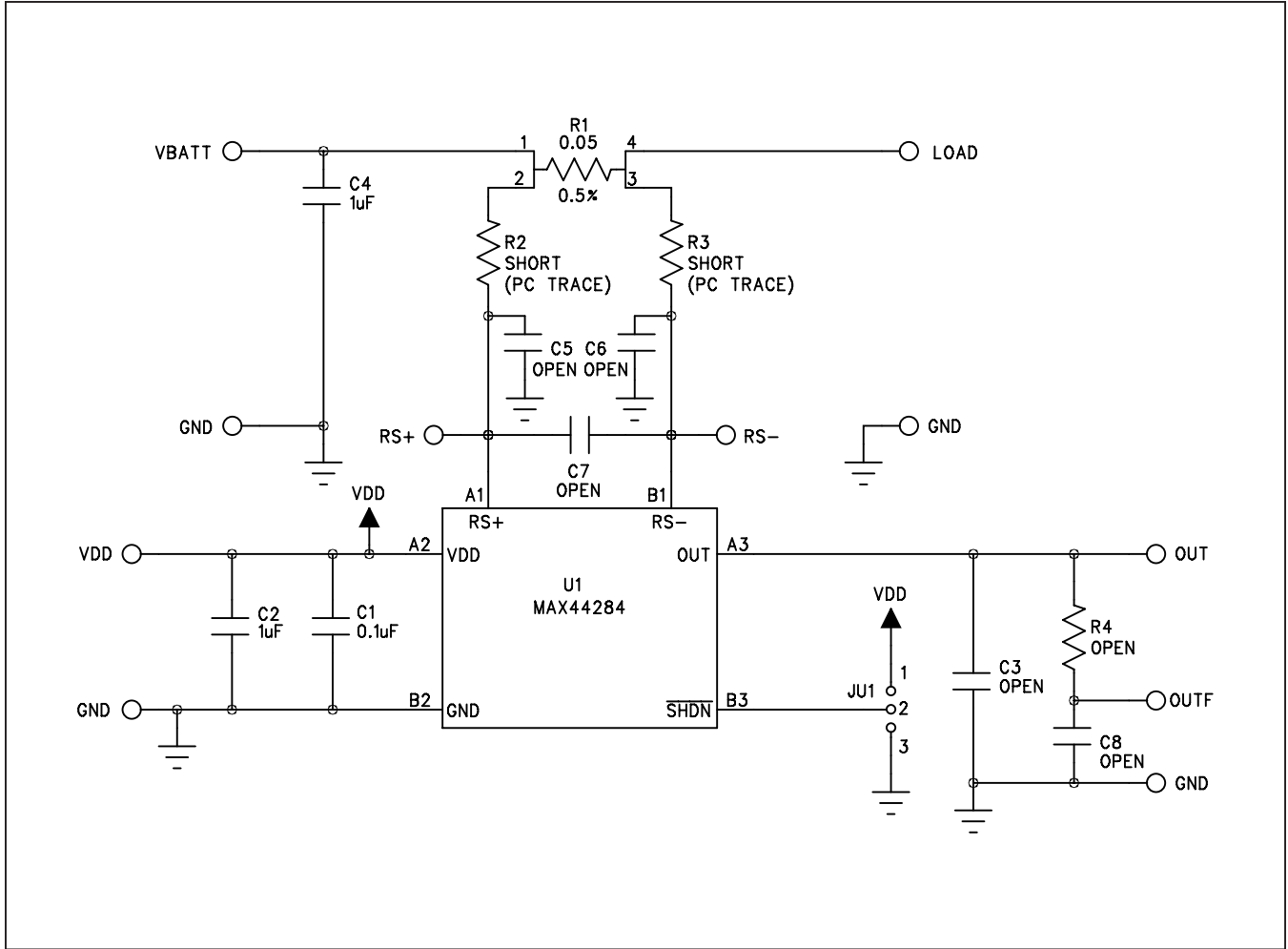

Figure 1. MAX44284 EV Kit Schematic

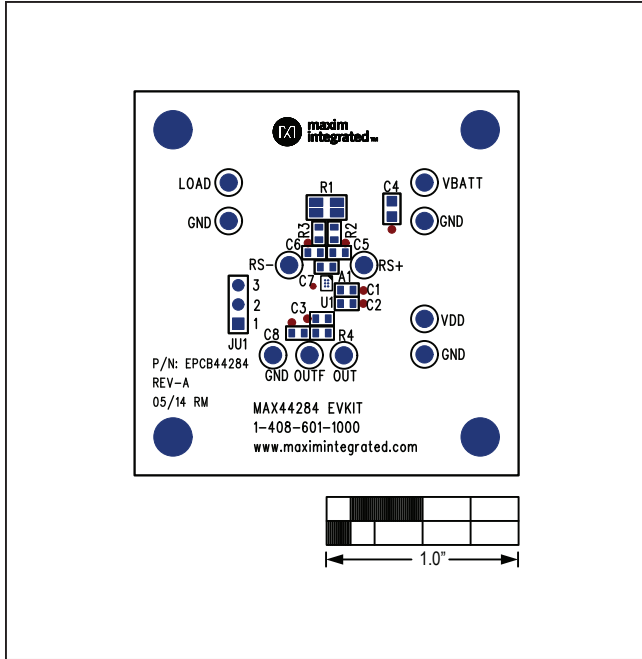

Figure 2. MAX44284 EV Kit Component Placement Guide—Component Side

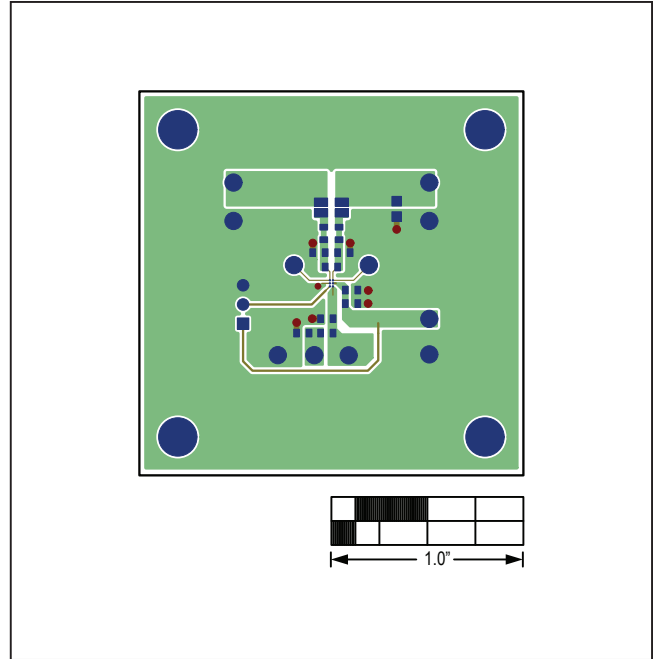

Figure 3. MAX44284 EV Kit PCB Layout—Component Side

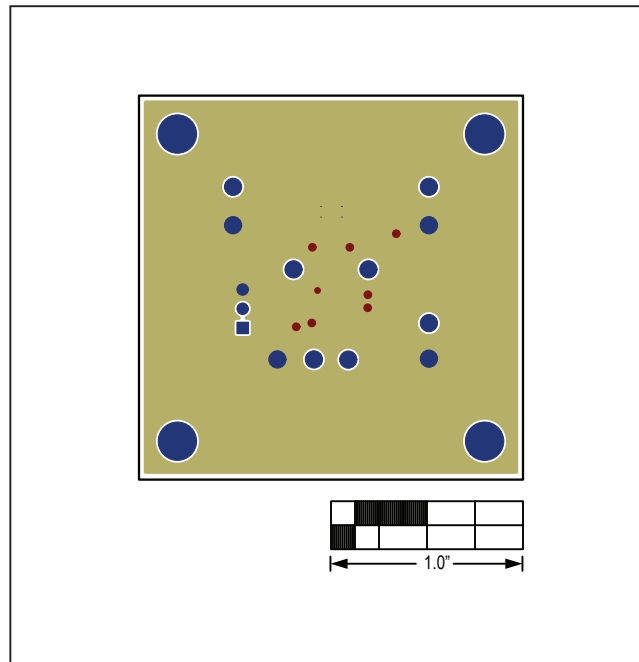

Figure 4. MAX44284 EV Kit PCB Layout—Solder Side

Ordering Information

PART	TYPE
MAX44284EVKIT#	EV Kit

#Denotes RoHS compliant.

Revision History

REVISION NUMBER	REVISION DATE	DESCRIPTION	PAGES CHANGED
0	7/14	Initial release	—

For pricing, delivery, and ordering information, please contact Maxim Direct at 1-888-629-4642, or visit Maxim Integrated's website at www.maximintegrated.com.

Maxim Integrated cannot assume responsibility for use of any circuitry other than circuitry entirely embodied in a Maxim Integrated product. No circuit patent licenses are implied. Maxim Integrated reserves the right to change the circuitry and specifications without notice at any time.



Компания «ЭлектроПласт» предлагает заключение долгосрочных отношений при поставках импортных электронных компонентов на взаимовыгодных условиях!

Наши преимущества:

- Оперативные поставки широкого спектра электронных компонентов отечественного и импортного производства напрямую от производителей и с крупнейших мировых складов;
- Поставка более 17-ти миллионов наименований электронных компонентов;
- Поставка сложных, дефицитных, либо снятых с производства позиций;
- Оперативные сроки поставки под заказ (от 5 рабочих дней);
- Экспресс доставка в любую точку России;
- Техническая поддержка проекта, помощь в подборе аналогов, поставка прототипов;
- Система менеджмента качества сертифицирована по Международному стандарту ISO 9001;
- Лицензия ФСБ на осуществление работ с использованием сведений, составляющих государственную тайну;
- Поставка специализированных компонентов (Xilinx, Altera, Analog Devices, Intersil, Interpoint, Microsemi, Aeroflex, Peregrine, Syfer, Eurofarad, Texas Instrument, Miteq, Cobham, E2V, MA-COM, Hittite, Mini-Circuits, General Dynamics и др.);

Помимо этого, одним из направлений компании «ЭлектроПласт» является направление «Источники питания». Мы предлагаем Вам помощь Конструкторского отдела:

- Подбор оптимального решения, техническое обоснование при выборе компонента;
- Подбор аналогов;
- Консультации по применению компонента;
- Поставка образцов и прототипов;
- Техническая поддержка проекта;
- Защита от снятия компонента с производства.



Как с нами связаться

Телефон: 8 (812) 309 58 32 (многоканальный)

Факс: 8 (812) 320-02-42

Электронная почта: org@eplast1.ru

Адрес: 198099, г. Санкт-Петербург, ул. Калинина, дом 2, корпус 4, литера А.