



a seacomp company

## SPECIFICATION FOR APPROVAL

<b>MODEL NUMBER</b>	
<b>PART NUMBER</b>	HDP-ALL-0004
<b>DESCRIPTION</b>	International adapters (AU, EU, UK, WHITE)
<b>CUSTOMER / PROJECT CODE</b>	
<b>REVISION</b>	A0
<b>DATE</b>	July 6, 2018

<b>CUSTOMER APPROVAL</b>	<b>DATE</b>
<b>SEACOMP ENGINEERING APPROVAL</b>	<b>DATE</b>

---

HDP Power – a SEACOMP company  
2546 Gateway Road  
Carlsbad, California 92009

Tel: 1.760.438.9600  
Email: sales@seacomp.com  
Website: www.hdp-power.com



<b>MODEL NUMBER</b>		<b>PAGE</b>	1 of 16
<b>PART NUMBER</b>	HDP-ALL-0004	<b>REVISION</b>	A0
<b>DESCRIPTION</b>	International adapters (AU, EU, UK, WHITE)	<b>DATE</b>	Jul 6, 2018

## Contents

Contents	1
Revision History	2
1 Scope	3
2 Quality Requirements	3
2.1 Product Specific Quality Requirements	3
2.2 General Quality Requirements	5
3 Cosmetic	7
3.1 Surface Definitions	7
3.2 Inspection Conditions	7
3.3 Cosmetic Defect Definitions	8
3.4 Size / Weight	12
4 Packaging	15
4.1 Drawing (Adapter Packaging)	15
4.2 Packaging Test	16
5 Warranty	16



<b>MODEL NUMBER</b>		<b>PAGE</b>	2 of 16
<b>PART NUMBER</b>	HDP-ALL-0004	<b>REVISION</b>	A0
<b>DESCRIPTION</b>	International adapters (AU, EU, UK, WHITE)	<b>DATE</b>	Jul 6, 2018

Revision History

<b>REV</b>	<b>DESCRIPTION</b>	<b>DATE</b>
A0	Initial Release	Jul 6, 2018

<b>MODEL NUMBER</b>		<b>PAGE</b>	3 of 16
<b>PART NUMBER</b>	HDP-ALL-0004	<b>REVISION</b>	A0
<b>DESCRIPTION</b>	International adapters (AU, EU, UK, WHITE)	<b>DATE</b>	Jul 6, 2018

## 1 Scope

This specification is for international adapters IEC Type-C, Type-G and Type-I to allow connectivity to worldwide AC receptacles.

Type-C: Europe except UK

Type-G: UK, Ireland, Malaysia, Singapore and Hong Kong

Type-I: Australia, New Zealand and Argentina

These Plugs allow connectivity into many other countries. Listing all is beyond the scope of this specification. Full list of these countries can be found in IEC website. "<http://www.iec.ch/worldplugs/>"

## 2 Quality Requirements

### 2.1 Product Specific Quality Requirements

#### 2.1.1 Mechanical / Electrical Requirements

##### 2.1.1.1 Paint and Print Test

In accordance with EN 60068-2-70

The printings have to withstand the testing procedures without any restrictions.

Test liquid	Mineral oils (example: Baby oil)
Wiping cycles	1,000
Contact pressure	1N ±0.2N

##### 2.1.1.2 Mechanical and Electrical Reliability

All electrical contacts and mechanically moving parts have to withstand a stress test of at least 3,000 simulated connecting cycles without any damage. After the test, the device must have 100% functionality. Connectors must comply with the manufacturer's requirements or relevant standards at minimum.

##### 2.1.1.3 Drop Test

This test requires the device to be dropped from a height of 1 meter onto a concrete floor. The drop should cover all surfaces including the 2 edges and all 4 corners. After the test, the device should have 100% functionality. There should not be any cracks, breaks or damage to any surface or have any loose internal components. Additionally, the ultrasonic weld joint should still be intact with minimum 80% coverage.

##### 2.1.1.4 Enclosure Crush Test

This test applies a uniform distributed weight of 250 Newtons on all surfaces for 5 seconds per surface. There should be no physical damage or effect on the products performance (i.e. operating folding AC blade, easy insertion of international adapters, snug USB connector fit).

#### 2.1.2 Climate Requirements

##### 2.1.2.1 Temperature Range

Full Functionality	0°C up to +50°C for AC/DC, -10°C up to +65°C for DC/DC
Storage Temperature	-20°C up to +85°C

##### 2.1.2.2 Thermal Shock (operational)

Low Temperature	-10°C (DC/DC), 0°C (AC/DC)
High Temperature	+65°C (DC/DC), 50°C (AC/DC)
T / t	15°C/min
Cycle Duration	1 hour
Number of Cycles	10

<b>MODEL NUMBER</b>		<b>PAGE</b>	4 of 16
<b>PART NUMBER</b>	HDP-ALL-0004	<b>REVISION</b>	A0
<b>DESCRIPTION</b>	International adapters (AU, EU, UK, WHITE)	<b>DATE</b>	Jul 6, 2018

Mode of Operation Minimum 75% full load  
 Requirement 100% functionality after test, without any damages or physical change

**2.1.2.3 Thermal Shock (non-operating)**

Low Temperature -20°C  
 High Temperature +85°C  
 T / t 15°C/min  
 Cycle Duration 1 hour  
 Number of Cycles 10  
 Mode of Operation Switched off  
 Requirement 100% functionality after test, without any damages or physical change

**2.1.2.4 Thermal Aging**

Temperature -20°C and +85°C  
 Duration 96 hours at each temperature  
 Mode of Operation Power off  
 Requirement 100% functionality after test, without any damages or physical change

**2.1.2.5 Humidity (non-condensing)**

Temperature +45°C  
 Humidity 95%  
 Duration 96 hours  
 Mode of Operation Power up no load  
 Requirement 100% functionality after test, without any damages or physical change

**2.1.2.6 Humidity (condensing)**

Upper Temperature +45°C  
 Lower Temperature +25°C  
 Humidity 95%  
 Test Cycle 5°C / max ramp rate  
 Duration 96 hours  
 Number of cycles 6  
 Mode of Operation Power up no load  
 Requirement 100% functionality after test, without any damages or physical change

**2.1.2.7 Salt Spray**

Follow ASTM B117 standard with the possible exceptions listed below.

Temperature 35°C + 1.1 / - 1.7°C  
 Salt Solution 5%+/-1 Salt solution (NaCl) in Distilled or D1193 Type IV water  
 PH 6.5 - 7.2  
 Fog Rate 1m - 2 mL / hr / 80sq.cm  
 Duration 24 hours

<b>MODEL NUMBER</b>		<b>PAGE</b>	5 of 16
<b>PART NUMBER</b>	HDP-ALL-0004	<b>REVISION</b>	A0
<b>DESCRIPTION</b>	International adapters (AU, EU, UK, WHITE)	<b>DATE</b>	Jul 6, 2018

## 2.2 General Quality Requirements

### 2.2.1 Product Related Requirements

#### 2.2.1.1 General Appearance

Follows cosmetic requirements listed in Section 4 of this specification.

#### 2.2.1.2 Emissions

The device must not produce any nuisance or unhealthy smell. A certificate must be made available proving the use of harmless materials.

#### 2.2.1.3 Product Safety

The product has to comply with the relevant requirements listed in IEC 60950 (ITE) and IEC 60601 (medical) whenever applicable.

Normal usage of the product must not result in any danger. In particular, any broken component parts, including electric components, may not result in any risk or danger of injury to the user. This is to be proven by a risk analysis during the product's development phase. Any potential hazard has to be indicated clearly in the user manual.

During normal use at an ambient temperature of 25°C, the housing (made of synthetic material) may warm up by 50K. Therefore, the maximum temperature of the parts could be as high as 75°C.

Individual "Hot Spots" (maximum size of 2 cm<sup>2</sup>) is acceptable if they are not located in the grip area. A warm up by 60K is acceptable in these "Hot Spots." Therefore, the maximum temperature of these parts could be 85°C.

For both normal use and "Hot Spot" instances, the housing must not exceed the maximum temperature of the applied synthetic.

Protective actions against confusing the poles of the electric connectors have to be taken for any internal parts or connectors with specific polarity.

Transportation, storage, and operation of the adapter must not create any hazard, personal injury or any material damage. This is guaranteed through the controllable quality of workmanship and material used.

It must be guaranteed that after contact with natural oils, the housing material's performance does not result in any dangerous situations to the customer.

#### 2.2.1.4 Recycling and Environmental Compatibility

Must comply with RoHS and REACH.

Quality Level, (AQL)

In accordance with DIN ISO 2859 Part 1

General test-level	II
Critical defects	AQL 0
Major defects	AQL 0.4
Minor defects	AQL 0.65

<b>MODEL NUMBER</b>		<b>PAGE</b>	6 of 16
<b>PART NUMBER</b>	HDP-ALL-0004	<b>REVISION</b>	A0
<b>DESCRIPTION</b>	International adapters (AU, EU, UK, WHITE)	<b>DATE</b>	Jul 6, 2018

## 2.2.2 Supplier Related Requirements

### 2.2.2.1 Demonstration of Quality

The supplier is obliged to maintain a quality assurance system which covers R&D and production specific items. This system must meet the requirements of ISO 9000-2008. A quality assurance plan (QA plan) is required for a project-specific proof of quality-assuring measures. The plan should be made available and presented upon request.

For the development phase, the QA plan needs to define milestones as proof of the reliability prognoses. The development results and the release by the customer need to also be included in this plan.

For the production phase, the QA plan has to focus on the detailed verification of all the planned QA steps from component procurement to delivery. Any acceptance or error criteria to be applied to the QA plan must meet the process capability index as defined in this specification.

### 2.2.2.2 Process Assurance

The quality capability has to be proven by a process capability of  $C_{pk} > 1.33$  and must be documented by a continuous monitoring of the production process. Parameters relevant for this process capability will be marked separately in the product's construction documents.

### 2.2.2.3 Reliability

The probability of failure and the return of devices for repair must be less than 1% per year.

<b>MODEL NUMBER</b>		<b>PAGE</b>	7 of 16
<b>PART NUMBER</b>	HDP-ALL-0004	<b>REVISION</b>	A0
<b>DESCRIPTION</b>	International adapters (AU, EU, UK, WHITE)	<b>DATE</b>	Jul 6, 2018

### 3 Cosmetic

#### 3.1 Surface Definitions

Level A is the primary surface. For example, the front face of the adapter.

Level B is a secondary surface that may be viewed periodically by the end user, but is not in direct view during normal use. For example, the Cable (AC and DC), the sides of the housing, and the back of the housing.

Level C surfaces are not visible by the end user. For example: inaccessible inside surfaces of the product.

#### 3.2 Inspection Conditions

4.2.1 Inspection Method: Light source: Cool white fluorescent lamp 750 – 1000Lux

4.2.2 Viewing Distance: 30cm

4.2.3 Viewing Angle: 0 – 90 Degrees

4.2.4 Part Rotation Angle During Inspection:

Vertical Rotation Angle 180 Degrees

Horizontal Rotation Angle 360 Degrees

4.2.5 Viewing Time:

10 seconds total for all surfaces



### 3.3 Cosmetic Defect Definitions

Defect	Level A	Level B	Level C
Scratches, Dents, and Burrs (see Note 1)	Single defect not exceeding total surface area 5.50 mm <sup>2</sup>	Two defects not exceeding total surface area 11 mm <sup>2</sup>	Accept if it does not affect fit or function
Hairline Scratches, Gate Blush/Trim, Stress	Use 25% Contrast Standard to accept or reject for visible hairline scratches with depth of < 0.1 mm (total surface area not to exceed limits set in surface scratch below)		
Surface Scratches, Scuffs (see Note 1)	Single defect not exceeding total surface area of 5.7 mm <sup>2</sup>	Two defects not exceeding total surface area 25 mm <sup>2</sup>	Accept if it does not affect fit or function
Chips, Nicks, Cracks or Broken Features	Not Allowed		
Flash, Burrs, Sink Marks (see Note 2)	Not Allowed	Less than 0.5mm	Accept if it does not affect fit or function
Discoloration	Follow color samples		
Parting Lines	See diagram		
General Stains (not permanent)	Not allowed		
Rust	Not allowed		
Printing	No missing text or mistakes allowed. All letters should be visible. Refer to approved sample.		

**Note 1:**

Area called out in these fields are calculated based on limit samples. The values are calculated based on average area covered by the features.

MODEL NUMBER		PAGE	9 of 16
PART NUMBER	HDP-ALL-0004	REVISION	A0
DESCRIPTION	International adapters (AU, EU, UK, WHITE)	DATE	Jul 6, 2018

**Parting Line: IMAGE IS FOR REFERENCE (IEC Type -I)**

Translation(备注):

1. Production for all components shall not be started before confirmation by HDP engineer.
2. Dimensions marked as ① are HDP control dimensions and must comply to Cmm≥ 1.33( to be inspected by IQC).
3. Dimensions marked as ② are customer control dimensions (to be inspected by IQC).
4. Dimensions unmarked please refer to 3D CAD(产品材料应符合ROHS).
5. Material should comply with ROHS standard (产品材料应符合ROHS).
6. Maximum draft angle is 1° unless otherwise notified(拔模斜度最大为1°，除另行通知外).
7. diameters unmarked in drawing are 0.2mm(图中未标注的半径应为0.2mm).
8. Material (材质): PC945 + CU (weight (重量): 9±5%)
9. Surface treatment (表面处理): 见差异表

REV.	DESCRIPTION	BY	DATE	EQN. NO.
①	初版发行	肖志斌	2016.01.21	
②	修改公差	肖志斌	2016.01.26	
③	增加注册	肖志斌	2016.01.29	

**差异表**

序号	料号	表面处理
1	860-00020	Cu镀镍, 塑胶为黑色素材, 表面哑纹, 哑纹型号: VD127, 外观表面不能有杂色.
2	860-00036	Cu镀镍, 塑胶为白色素材, 表面哑纹, 哑纹型号: VD127, 外观表面不能有杂色.

**Third Angle Projection**

This drawing is the property of HDP corporation. Any reproduction, distribution, or use without the written permission of HDP is strictly prohibited. Any review or distribution by others is strictly prohibited and unauthorized.

Version NO.: A2  
 Drawn By: 肖志斌  
 Checked By: 肖志斌  
 Approved By: 肖志斌  
 Date: 2016.01.29

Dimension	F	G	H	J
0-8	±0.08	±0.1	±0.1	±0.2
8-25	±0.08	±0.1	±0.15	±0.3
25-60	±0.12	±0.2	±0.25	±0.4
60-250	±0.25	±0.3	±0.4	±0.6
250-800	±0.5	±0.6	±0.8	±1.0
800-2500	±1.0	±1.0	±1.5	±1.7
2500+	±2.0	±2.0	±3.0	±3.0

Part Name: AU adapters  
 Part NO.: 860-00020  
 HDP Model NO.: HDP Adapters

MODEL NUMBER		PAGE	10 of 16
PART NUMBER	HDP-ALL-0004	REVISION	A0
DESCRIPTION	International adapters (AU, EU, UK, WHITE)	DATE	Jul 6, 2018

(IEC Type -C)

- Translation(备注):
- 1.production for all components shall not be started before confirmation by HDP engineer.  
(所有零件都必须经工程师确认后方可生产)
  - 2.Dimensions marked as ① are HDP control dimensions and must comply to Cmm> 1.33(to be inspected by IQC).  
(有①标记的尺寸为重要管制尺寸, 其Cmm公差为1.33 (IQC必检))
  - 3.Dimensions marked as ② are customer control dimensions (to be inspected by IQC).  
(有②标记的尺寸为客户重要管制 (IQC必检) 尺寸)
  - 4.Dimensions unmarked please refer to 3D CAD(未标注的尺寸请参考3D CAD).
  - 5.Material should comply with ROHS standard(产品材质应符合ROHS).
  - 6.Maximum draft angle is 1° unless otherwise notified(拔模斜度最大为1°, 除非行通知外).
  - 7.diameters unmarked in drawing are 0.2mm(图中未标注的半径应为0.2mm).
  - 8.Material (材质): PC945 + Cu
  - 9.Surface treatment (表面处理): 见差异表 (weight (重量):  $\pm 5\%$ ).

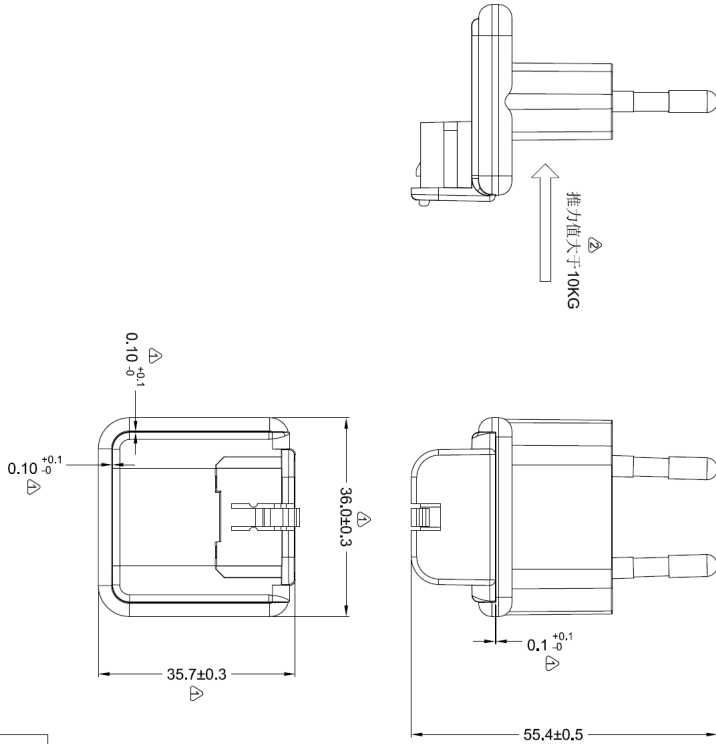

差异表

序号	料号	表面处理
1	860-00018	Cu镀镍, 塑胶为黑色素材 表面喷纹, 喷纹型号: VD127, 外观表面不能有杂色.
2	860-00034	Cu镀镍, 塑胶为白色素材 表面喷纹, 喷纹型号: VD127, 外观表面不能有杂色

Version NO. : _____		Drawn By : _____		Checked By : _____		Approved By : _____	
Date : 2016.01.29		Date : _____		Date : _____		Date : _____	

Dimension	F	G	H	J
0-8	+0.05	+0.1	+0.1	+0.2
8-25	+0.06	+0.15	+0.15	+0.3
25-80	+0.12	+0.2	+0.25	+0.4
80-250	+0.25	+0.3	+0.4	+0.6
250-800	+0.5	+0.6	+0.8	+1.0
800-2500	+1.0	+1.0	+1.5	+1.7
2500-	+2.0	+2.0	+3.0	+3.0

REV.	DESCRIPTION	BY	DATE	ECN NO.
①	初版发行	肖志斌	2016.01.21	
②	修改公差	肖志斌	2016.01.28	
③	增加注释	肖志斌	2016.01.29	

MODEL NUMBER		PAGE	11 of 16
PART NUMBER	HDP-ALL-0004	REVISION	A0
DESCRIPTION	International adapters (AU, EU, UK, WHITE)	DATE	Jul 6, 2018

(IEC Type -G)

Translation(备注):  
 1. production for all components shall not be started before confirmation by HDP engineer.  
 (所有零部件都必须经过工程师确认后才可以生产)  
 2. Dimensions marked as ① are HDP control dimensions and must comply to Comp> 1.33(to be inspected by IQC),  
 (带①标注的尺寸为客户重要管制尺寸,其公差需≥1.33 (IQC必检))  
 3. Dimensions marked as ② are customer control dimensions (to be inspected by IQC),  
 (带②标注的尺寸为客户重要管制 (IQC必检) 尺寸)  
 4. Dimensions unmarked please refer to 3D CAD(未标注的尺寸请参照3D CAD).  
 5. Material should comply with ROHS standard(产品材质应符合ROHS).  
 6. Maximum draft angle is 1° unless otherwise notified(投模斜度最大为1°, 除非有通知外).  
 7. diameters unmarked in drawing are 0.2mm(图中未标注的半径应为0.2mm).  
 8. Material (材质) : PC945 + Cu (weight (重量) : 0.45g)  
 9. Surface treatment (表面处理) : 见差异表

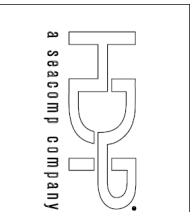
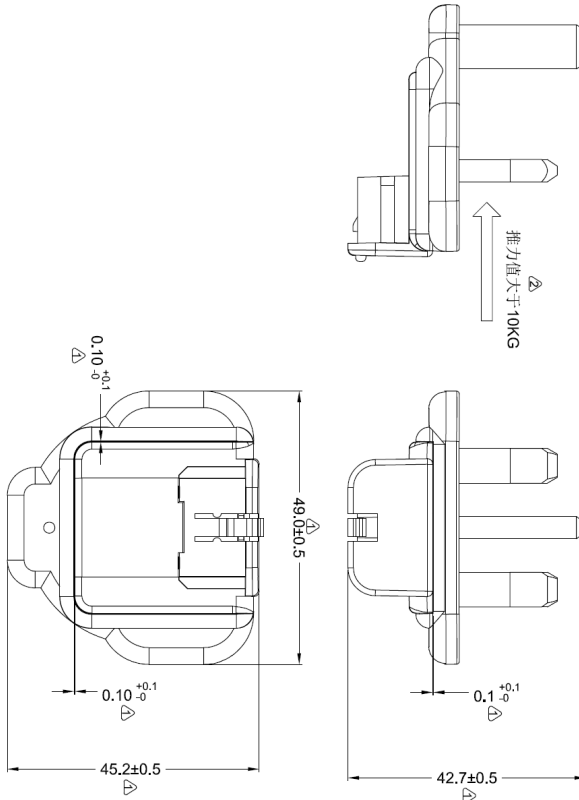

Third Angle Projection	Version NO. : A2	Scale : 1:1	Unit : MM
Question	Drawn By	Sheet : 1/1	Size : A4
Sample	Drawn By	Checked By	Approved By
Tooling	肖志斌		
Official Issue	2016.01.29		

This drawing is the property of HDP corporation. It contains material that is confidential and/or solely for the use of the customer. It is not to be reproduced or distributed without the written permission of HDP corporation to the full extent of the law.

差异表

序号	料号	表面处理
1	860-00019	Cu镀镍, 塑胶为黑色素材, 表面喷纹, 喷纹型号: V0127, 外观表面不能有杂色, Cu镀镍, 塑胶为白色素材, 表面喷纹, 喷纹型号: V0127, 外观表面不能有杂色.
2	860-00035	

REV.	DESCRIPTION	BY	DATE	ECN NO.
①	初版发行	肖志斌	2016.01.21	
②	修改公差	肖志斌	2016.01.26	
③	增加注释	肖志斌	2016.01.29	

<b>MODEL NUMBER</b>		<b>PAGE</b>	12 of 16
<b>PART NUMBER</b>	HDP-ALL-0004	<b>REVISION</b>	A0
<b>DESCRIPTION</b>	International adapters (AU, EU, UK, WHITE)	<b>DATE</b>	Jul 6, 2018

### 3.4 Size / Weight IEC Type -I

**Translation(注记):**  
 1. production for all components shall not be started before confirmation by HDP engineer.  
 (所有零部件都必须经过工程师确认后才可以生产.)  
 2. Dimensions marked as ① are HDP control dimensions and must comply to Cam2-1.33(① to be inspected by IQC).  
 (有“①”标记的尺寸为重要管制尺寸, 其公差需≥1.33 (IQC必检))  
 3. Dimensions marked as ② are customer control dimensions (to be inspected by IQC).  
 (有“②”标记的尺寸为客户重要管制 (IQC必检) 尺寸.)  
 4. Dimensions unmarked please refer to 3D CAD. (未标示的尺寸请参考3D CAD).  
 5. Material should comply with RoHS standard (产品材质应符合ROHS).  
 6. Material (材质): PC945 + Cu  
 7. Surface treatment (表面处理): 见差异表 (weight) (重量): 9±5%

文字高度约为: 2.5MM

剖面 A-A

REV.	DESCRIPTION	BY	DATE	ECN NO.
①	初版发行	肖志斌	2016.01.21	
②	修改公差	肖志斌	2016.01.26	
③	增加注释	肖志斌	2016.01.29	
④	增加YYWW	肖志斌	2017.04.20	ECN-48

序号	料号	表面处理
1	860-00020	Cu镀镍, 塑胶为黑色素材, 表面喷纹, 晒纹型号: VD127, 外观表面不能有杂色.
2	860-00036	Cu镀镍, 塑胶为白色素材, 表面喷纹, 晒纹型号: VD127, 外观表面不能有杂色.

Dimension		F		G		H		J	
6-25	±0.09	±0.1	±0.1	±0.1	±0.2				
25-40	±0.12	±0.2	±0.25	±0.4	±0.4				
40-250	±0.25	±0.3	±0.4	±0.4	±0.6				
250-800	±0.5	±0.6	±0.8	±1.0	±1.7				
800-2500	±1.0	±1.0	±1.5	±1.7					
2500-	±2.0	±2.0	±3.0	±3.0					

Version NO.:	Scale:	UNIT:
A3	1:1	MM

Quotation	Drawn By	Checked By	Approved By
	肖志斌		

Version NO.:	Scale:	UNIT:
A3	1:1	MM

Quotation	Drawn By	Checked By	Approved By
	肖志斌		

Version NO.:	Scale:	UNIT:
A3	1:1	MM

Quotation	Drawn By	Checked By	Approved By
	肖志斌		

MODEL NUMBER		PAGE	13 of 16
PART NUMBER	HDP-ALL-0004	REVISION	A0
DESCRIPTION	International adapters (AU, EU, UK, WHITE)	DATE	Jul 6, 2018

### IEC Type -C

- Translation(注记):  
 1. production for all components shall not be started before confirmation by HDP engineer.  
 (所有零部件都经过延期工程师确认后才可以生产)  
 2. Dimensions marked as ① are HDP control dimensions and must comply to Cpm± 1.33( to be inspected by IQC).  
 (有①标记的尺寸为重要管制尺寸, 其Cpm公差为: 1.33 (IQC必检))  
 3. Dimensions marked as ② are customer control dimensions (to be inspected by IQC).  
 (有②标记的尺寸为客户重要管制 (IQC必检) 尺寸)  
 4. Dimensions unmarked please refer to 3D CAD/ 未标示的尺寸请参考3D CAD).  
 5. Material should comply with ROHS standard (产品材质应符合ROHS).  
 6. Material (材质) : PC/PA6 + Cu (weight) (重量) : ~ 9±5%.  
 7. Surface treatment (表面处理) : 见差异表

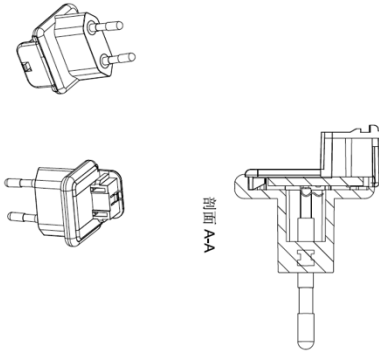
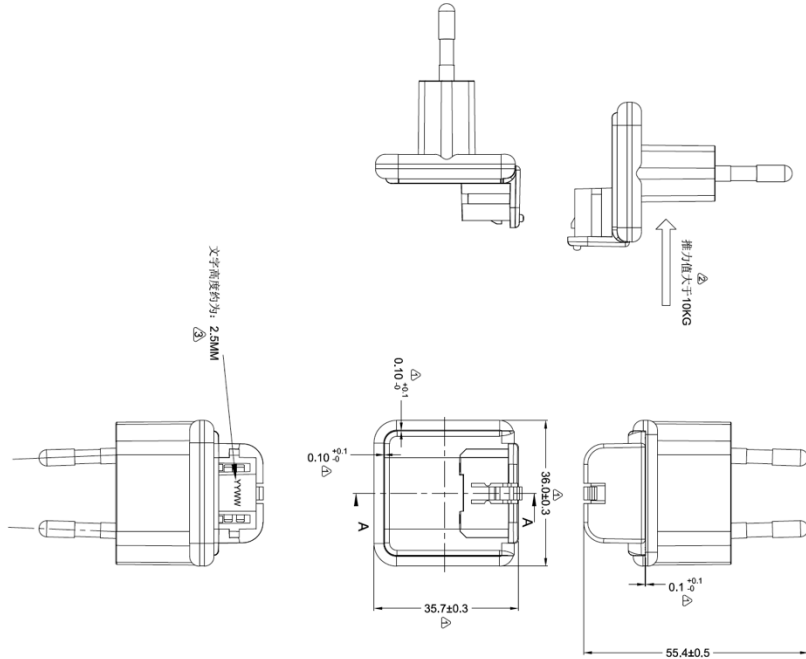

#### 差异表

序号	料号	表面处理
1	860-00018	Cu镀镍, 塑胶为黑色素材, 表面晒纹, 晒纹型号: VD127, 外观表面不能有杂色。
2	860-00034	Cu镀镍, 塑胶为白色素材, 表面晒纹, 晒纹型号: VD127, 外观表面不能有杂色



a seacom company

Third Angle Projection

This drawing is the property of HDP corporation. It is to be used for the sole use of the intended recipient. Any permission to the full extent of the law.

Version NO.: A3  
 Drawn By: 肖志斌  
 Checked By: 肖志斌  
 Approved By: 肖志斌  
 2017.04.20

Scale: 1:1  
 Unit: MM  
 Size: A3

Dimension: F G H I J  
 Anguler: ±0.25°  
 Model NO./Project Name: Adapters  
 Finished Goods Part NO.:  
 Part NO.: 见差异表  
 Part Name: EU adapters  
 FMEB004

REV.	DESCRIPTION	BY	DATE	ECN NO.
①	初版发行	肖志斌	2016.01.21	
②	修改公差	肖志斌	2016.01.26	
③	增加注释	肖志斌	2017.04.20	ECN-48
④	增加YYWW			

<b>MODEL NUMBER</b>		<b>PAGE</b>	14 of 16
<b>PART NUMBER</b>	HDP-ALL-0004	<b>REVISION</b>	A0
<b>DESCRIPTION</b>	International adapters (AU, EU, UK, WHITE)	<b>DATE</b>	Jul 6, 2018

### IEC Type -G

- Translation(注记):  
 1. Production for all components shall not be started before confirmation by HDP engineer.  
 (所有零部件都需经近翔工程师确认后才可生产)  
 2. Dimensions marked as (D) are HDP control dimensions and must comply to Comp-1.33(10) to be inspected by IQC.  
 (所有(D)标记的尺寸为重要管制尺寸,其Cpm必需≤1.33 (IQC必检))  
 3. Dimensions marked as (M) are customer control dimensions (to be inspected by IQC).  
 (所有(M)标记的尺寸为客户重要管制 (IQC必检) 尺寸)  
 4. Dimensions unmarked please refer to 3D CAD. 未标示的尺寸请参考3D CAD).  
 5. Material should comply with ROHS standard(产品材质应符合ROHS).  
 6. Material (材质): PC945 + Cu (重量): ±5%  
 7. Surface treatment (表面处理): 见差异表

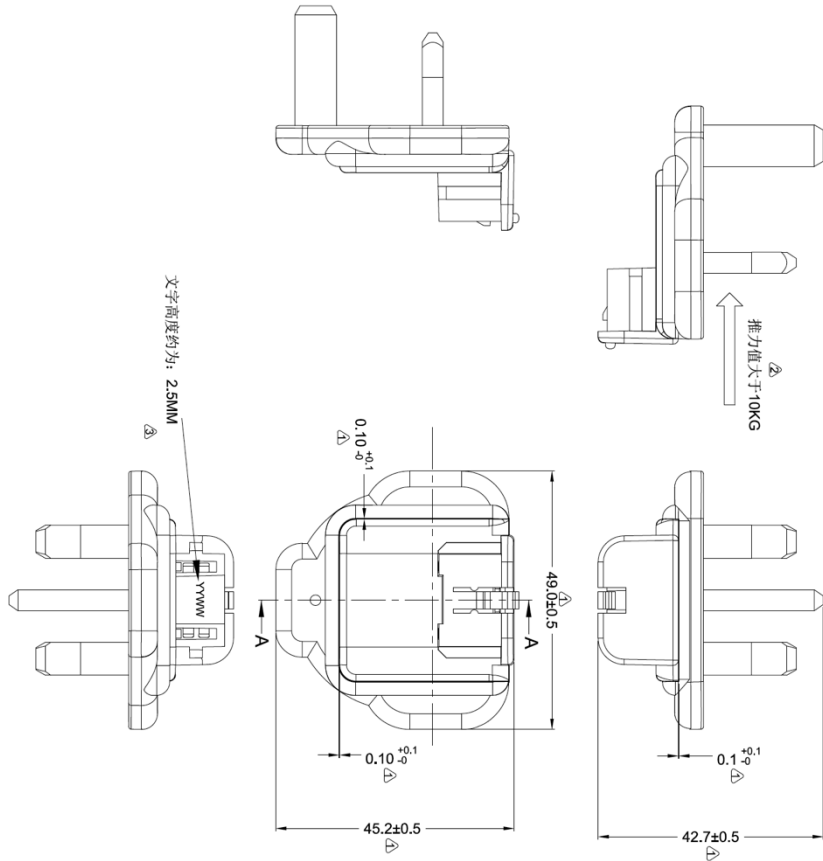

REV.	DESCRIPTION	BY	DATE	ECN NO.
①	初版发行	肖志斌	2016.01.21	
②	修改公差	肖志斌	2016.01.26	
③	增加注释	肖志斌	2016.01.29	
④	增加YWW	肖志斌	2017.04.20	ECN-88

剖面 A-A

差异表

序号	料号	表面处理
1	880-00019	Cu镀镍, 塑胶为黑色素材, 表面晒纹, 晒纹型号: V0127, 外观表面不能有杂色.
2	880-00035	Cu镀镍, 塑胶为白色素材, 表面晒纹, 晒纹型号: V0127, 外观表面不能有杂色.

a seacomp company

Third Angle Projection

Quotation	Version NO.:	Scale:	Sheet:	Unit:	Size:	Approved By	Dimension	Tolerance				Part Name
Sample	Drawn By	1:1	1/1	MM	A3	肖志斌	25-80	F	G	H	J	UK adapters
Tooling	Checked By					肖志斌	80-250	±0.1	±0.1	±0.1	±0.2	见差异表
Critical Issue	2017.04.20					肖志斌	250-	±0.1	±0.1	±0.1	±0.1	见差异表

Model NO. / Project Name: Adapters

Finished Goods Part NO.:

Part Name: UK adapters

FME804

<b>MODEL NUMBER</b>		<b>PAGE</b>	15 of 16
<b>PART NUMBER</b>	HDP-ALL-0004	<b>REVISION</b>	A0
<b>DESCRIPTION</b>	International adapters (AU, EU, UK, WHITE)	<b>DATE</b>	Jul 6, 2018

## 4 Packaging

### 4.1 Drawing (Adapter Packaging)

**Translation(注意):**

1. Production for all components shall not be started before confirmation by HDP engineer.  
(所有零部件都必须经近期工程师确认后才可生产。)

2. Dimensions marked as ① are HDP control dimensions and must comply to Cmm± 0.33(to be inspected by IQC).  
(有①标记的尺寸为重要管制尺寸, 其公差需±0.33 (IQC必检))

3. Dimensions marked as ② are customer control dimensions (to be inspected by IQC).  
(有②标记的尺寸为客户重要管制 (IQC必检) 尺寸)

4. Dimensions unmarked please refer to 3D CAD(未标注的尺寸请参照3D CAD).

5. Material should comply with ROHS standard(产品材质应符合ROHS).

6. Material (材质): \_\_\_\_\_ (weight (重量): **950%**).

7. Surface treatment (表面处理): \_\_\_\_\_.

① 每PCS产品需用PE袋包装

② 1白盒装 1PCS EU, 1PCS AU, 1PCS UK.

③ 1外箱装100PCS白盒, 每PCS白盒装3PCS产品, 1外箱共装300PCS产品。  
EU 100PCS  
AU 100PCS  
UK 100PCS

④ 总毛重为: 8500g(8.5kg)  
总净重为: 6100g(6.1kg)  
重量仅供参考。

⑤ 白盒  
45.0  
30.0  
55.0

外箱  
215.0  
175.0  
205.0

REV.	DESCRIPTION	BY	DATE	ECN NO.
1	初版发行 (Initial Release)	肖志斌	2018.06.29	

Third Angle Projection		This standard is the property of HDP corporation. In order to maintain its confidential and legal, the reproduction or distribution by other is strictly prohibited and is subject to the approval of the HDP.	
Version: A0.1	Sheet: 1/1	Size: A3	Model NO./Project Name: ADAPTER
Quotation	Drawn By: 肖志斌	Checked By: /	Approved By: /
Sample	2018.06.29	2018.06.29	2018.06.29
Tooling			
Initial Issue			

序号	名称	料号	描述	用量
1	PE袋	840-00132		100PCS
2	白盒	840-00132		100PCS
3	垫板	840-00280		3PCS
4	外箱	840-00279		1PCS
5	发货标签	840-00150		3PCS

Dimension	F	G	H	J	Part NO.
0-4	±0.05	±0.1	±0.1	±0.2	公差表
6-25	±0.07	±0.15	±0.25	±0.3	
26-80	±0.12	±0.2	±0.25	±0.4	
80-200	±0.25	±0.3	±0.4	±0.6	
200-800	±0.5	±0.6	±0.8	±1.0	
800-2500	±1.0	±1.5	±1.7	±2.0	
2500-	±2.0	±3.0	±3.0	±3.0	

Model NO./Project Name: ADAPTER

Finished Goods Part NO.: /

Drawing Name: 包装规格图 (Packaging Assembly Drawing)

Model NO./Project Name: FIBERDIA



<b>MODEL NUMBER</b>		<b>PAGE</b>	16 of 16
<b>PART NUMBER</b>	HDP-ALL-0004	<b>REVISION</b>	A0
<b>DESCRIPTION</b>	International adapters (AU, EU, UK, WHITE)	<b>DATE</b>	Jul 6, 2018

## 4.2 Packaging Test

1	Bulk product	<p>Drop package on each side for a total of 10 drops (2 opposite corners, 3 adjacent sides of bottom corner, then all 6 faces) per system on concrete floor from a height of 1.0 meter. This is an operational test.</p> <p>Pass/Fail Criteria:            1. The systems shall pass Functional Test.            2. No visible damage to product and gift box.</p>
2	Drop test for Packaged Product (gift box, clamshell, etc.)	<p>Drop fully packaged products (in gift box or clamshell) onto a concrete floor from height of 153cm for 10 drops on the six surfaces and four corners.</p> <p>Pass/Fail Criteria:            1. The systems shall pass Functional Test.            2. Paper or PET deformation is acceptable. No damage in product integrity of packaging materials (e.g. sealed edge openings) is allowed.</p>
3	Sinusoidal Vibration	<p>Test with sine wave that will sweep the frequency from 7 - 500 hertz for construction test; 5 - 70 hertz for packaging test. Displacement &gt;3.15mm. Total test duration time shall be 30 min (10 min per axis). Test shall be performed in three mutually perpendicular axes: Z-axis (vertical), Y-axis (fore-aft), and X-axis (lateral).</p> <p>Pass/Fail Criteria:            The UUT and packaging shall withstand the above test procedure without visible damage or performance decline during operation.</p>

## 5 Warranty

One year warranty for defects arising from workmanship and materials per the SEACOMP Warranty, RMA, and Failure Analysis Policy.



Компания «ЭлектроПласт» предлагает заключение долгосрочных отношений при поставках импортных электронных компонентов на взаимовыгодных условиях!

Наши преимущества:

- Оперативные поставки широкого спектра электронных компонентов отечественного и импортного производства напрямую от производителей и с крупнейших мировых складов;
- Поставка более 17-ти миллионов наименований электронных компонентов;
- Поставка сложных, дефицитных, либо снятых с производства позиций;
- Оперативные сроки поставки под заказ (от 5 рабочих дней);
- Экспресс доставка в любую точку России;
- Техническая поддержка проекта, помощь в подборе аналогов, поставка прототипов;
- Система менеджмента качества сертифицирована по Международному стандарту ISO 9001;
- Лицензия ФСБ на осуществление работ с использованием сведений, составляющих государственную тайну;
- Поставка специализированных компонентов (Xilinx, Altera, Analog Devices, Intersil, Interpoint, Microsemi, Aeroflex, Peregrine, Syfer, Eurofarad, Texas Instrument, Miteq, Cobham, E2V, MA-COM, Hittite, Mini-Circuits, General Dynamics и др.);

Помимо этого, одним из направлений компании «ЭлектроПласт» является направление «Источники питания». Мы предлагаем Вам помощь Конструкторского отдела:

- Подбор оптимального решения, техническое обоснование при выборе компонента;
- Подбор аналогов;
- Консультации по применению компонента;
- Поставка образцов и прототипов;
- Техническая поддержка проекта;
- Защита от снятия компонента с производства.



#### Как с нами связаться

**Телефон:** 8 (812) 309 58 32 (многоканальный)

**Факс:** 8 (812) 320-02-42

**Электронная почта:** [org@eplast1.ru](mailto:org@eplast1.ru)

**Адрес:** 198099, г. Санкт-Петербург, ул. Калинина, дом 2, корпус 4, литера А.