

## NTC Thermistors, Flex Foil Sensors



### FEATURES

- Rapid response time down to 2 s
- Suitable for narrow space applications
- High flexibility of the foil
- Insulated and humidity resistant
- A strain relief hole is included in the flex design to avoid traction to the sensor head
- Gold plated terminations
- AEC-Q200 qualified
- Material categorization: For definitions of compliance please see [www.vishay.com/doc?99912](http://www.vishay.com/doc?99912)

**RoHS**  
COMPLIANT

### QUICK REFERENCE DATA

PARAMETER	VALUE	UNIT
Resistance value at 25 °C	10K, 47K	Ω
Tolerance on $R_{25}$ -value	± 3	%
$B_{25/85}$ -value	3960	K
Tolerance on $B_{25/85}$ -value	± 1	%
Operating temperature range at zero power	- 40 to 125	°C
Thermal time constant on heating <sup>(1)</sup>	2	s
Thermal gradient	< 0.02	K/K
Minimum dielectric withstanding voltage	500	V <sub>AC</sub>
Minimum insulation resistance	10	MΩ
Maximum dissipation at 25 °C	60	mW
Climatic category (LCT/UCT/days)	40/125/56	
Weight (without connector)	0.06	g

#### Note

- <sup>(1)</sup> Measured from 25 °C air to 125 °C heated plate, pressed on the surface

### DESIGNERS OPTIONS

- Other dimensions and various shapes of the flex circuit are available on request
- A 3D solid model is available on request

#### Note

- FFC/FPC = Flexible Film Circuit/Flexible Printed Circuit

### APPLICATIONS

- Consumer appliances and white goods
- Power supply (heat-sinks)
- Battery, displays, LED
- Industrial applications, robotics
- Boilers
- EV and HV batteries

### DESCRIPTION

- Miniature NTC temperature sensor on flex foil, insulated used for temperature sensing and control
- Surface temperature sensor with low thermal mass and rapid response time on surface

### MOUNTING

- The sensor head can be pressed on the surface with means of insulating material (silicone foam) or spring
- The sensor head can also be glued with a double-face temperature resistant adhesive
- The sensor end can be connected to PCB counter-connector or wire-to-wire connector or soldered to conductors, or crimped with FFC connectors and ZiF connectors
- Remark: The response time and thermal gradient are dependant of the application and of the way of mounting the sensor in place

### ELECTRICAL DATA AND ORDERING INFORMATION

VISHAY SAP ORDERING NUMBER	$R_{25}$ -VALUE (Ω)	$R_{25}$ TOL. (± %)	$B_{25/85}$ -VALUE (K)	$B_{25/85}$ TOL. (± %)	DESCRIPTION	R/T TABLE
NTCAFLEX05103HH	10 000	3	3960	1	NTC Flex05 10K 3 % 3960 K 25 mm	Table 1
NTCAFLEX05473HH	47 000	3	3960	1	NTC Flex05 47K 3 % 3960 K 25 mm	Table 2

**SAP CODIFICATION**

Part Number: NTCAFLEX01473HH

<div style="display: flex; justify-content: space-around; font-weight: bold; font-size: 1.2em;"> <span>N</span><span>T</span><span>C</span><span>A</span><span>F</span><span>L</span><span>E</span><span>X</span><span>0</span><span>5</span><span>4</span><span>7</span><span>3</span><span>H</span><span>H</span><span> </span> </div>													
MODEL	ASSEMBLY	FLEX SENSOR	MECHANICAL EXECUTION	RESISTANCE VALUE	TOLERANCE ON $R_{25}$	B-VALUE RANGE			OPTION				
<b>NTC</b>	<b>A</b>	<b>FLEX</b>	<b>05</b>	<b>103</b> = $10 \times 10^3 \Omega$ <b>473</b> = $47 \times 10^3 \Omega$	<b>H</b> = $\pm 3\%$	<b>L</b> (low) = $3000 \leq B_{25/85} < 3500$ <b>M</b> (medium) = $3500 \leq B_{25/85} < 3750$ <b>H</b> (high) = $3750 \leq B_{25/85} < 4000$ <b>X</b> (very high) = $4000 \leq B_{25/85} < 4250$			<b>Blank</b>				

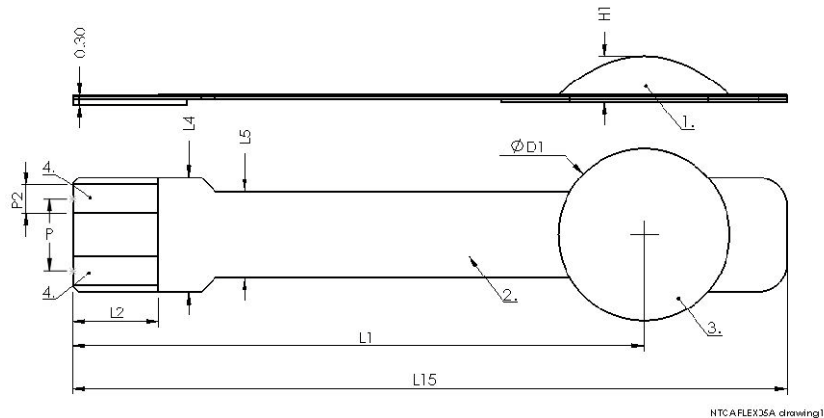
**MECHANICAL DATA**

**DIMENSIONS** in millimeters

L1	L15	L2	Ø D1	L4	L5	H1	P
$20 \pm 1$	$25 \pm 1$	$3 \pm 0.5$	$6 \pm 0.5$	$4 \pm 1$	$3 \pm 1$	$1.40 \pm 0.2$	2.50

1. NTC on flex foil circuit
2. Flex foil circuit
3. High quality modified epoxy glob top
4. Conductive tracks

**RELIABILITY TEST** (following IEC 60068 test methods)

TEST	PROCEDURE	REQUIREMENT
Dry heat, steady state	125 °C; 1000 h	$\Delta R/R \leq 3\%$
Damp heat, steady state	56 days at 40 °C 90 % to 95 % RH	$\Delta R/R \leq 3\%$
Rapid change of temperature	- 40 °C to + 125 °C; 100 cycles	$\Delta R/R \leq 3\%$



R/T TABLE 1

R <sub>25</sub> -VALUE (kΩ)	R <sub>25</sub> TOL. (%)	B <sub>25/85</sub> -VALUE (K)	B <sub>25/85</sub> TOL. (%)	SAP MATERIAL NO.
10	± 3	3960	± 1	NTCAFLEX05103HH

RESISTANCE VALUES AT INTERMEDIATE TEMPERATURES

TEMP. (°C)	R <sub>(T)/R<sub>25</sub></sub>	RESISTANCE (Ω)	ΔR/R (%)	α (%/K)	ΔT (K)	R <sub>min.</sub> (Ω)	R <sub>max.</sub> (Ω)
- 40	34.7116	347 116	10.8031	- 6.66	1.62	309 617	384 616
- 35	25.0089	250 089	10.0392	- 6.45	1.56	224 982	275 196
- 30	18.2023	182 023	9.3093	- 6.25	1.49	165 078	198 968
- 25	13.3804	133 804	8.6110	- 6.06	1.42	122 282	145 326
- 20	9.9313	99 313	7.9424	- 5.87	1.35	91 425	107 201
- 15	7.4408	74 408	7.3017	- 5.68	1.28	68 974	79 841
- 10	5.6257	56 257	6.6871	- 5.50	1.22	52 495	60 019
- 5	4.2910	42 910	6.0971	- 5.33	1.14	40 294	45 526
0	3.3009	33 009	5.5303	- 5.16	1.07	31 184	34 835
5	2.5602	25 602	4.9853	- 5.00	1.00	24 326	26 879
10	2.0015	20 015	4.4608	- 4.85	0.92	19 122	20 908
15	1.5767	15 767	3.9558	- 4.70	0.84	15 143	16 391
20	1.2512	12 512	3.4692	- 4.55	0.76	12 078	12 946
25	1.0000	10 000	3.0000	- 4.41	0.68	9700.0	10 300
30	0.8047	8046.8	3.2266	- 4.28	0.75	7787.1	8306.4
35	0.6518	6517.6	3.4459	- 4.15	0.83	6293.1	6742.2
40	0.5313	5312.5	3.6581	- 4.03	0.91	5118.2	5506.9
45	0.4357	4356.6	3.8637	- 3.91	0.99	4188.3	4524.9
50	0.3594	3593.6	4.0629	- 3.79	1.07	3447.6	3739.6
55	0.2981	2981.0	4.2560	- 3.68	1.16	2854.1	3107.8
60	0.2486	2486.2	4.4434	- 3.58	1.24	2375.7	2596.6
65	0.2084	2084.3	4.6252	- 3.48	1.33	1987.9	2180.7
70	0.1756	1756.2	4.8017	- 3.38	1.42	1671.9	1840.5
75	0.1487	1486.9	4.9732	- 3.28	1.52	1412.9	1560.8
80	0.1265	1264.7	5.1397	- 3.19	1.61	1199.7	1329.7
85	0.1081	1080.6	5.3017	- 3.10	1.71	1023.3	1137.9
90	0.0927	927.23	5.6204	- 3.02	1.86	875.11	979.34
95	0.0799	798.94	5.9309	- 2.94	2.02	751.56	846.33
100	0.0691	691.16	6.2335	- 2.86	2.18	648.08	734.25
105	0.0600	600.23	6.5286	- 2.78	2.35	561.04	639.42
110	0.0523	523.20	6.8163	- 2.71	2.51	487.53	558.86
115	0.0458	457.68	7.0970	- 2.64	2.69	425.20	490.17
120	0.0402	401.76	7.3709	- 2.57	2.86	372.15	431.37
125	0.0354	353.85	7.6383	- 2.51	3.05	326.82	380.87



R/T TABLE 2

R <sub>25</sub> -VALUE (kΩ)	R <sub>25</sub> TOL. (%)	B <sub>25/85</sub> -VALUE (K)	B <sub>25/85</sub> TOL. (%)	SAP MATERIAL NO.
47	± 3	3960	± 1	NTCAFLEX05473HH

RESISTANCE VALUES AT INTERMEDIATE TEMPERATURES

TEMP. (°C)	R <sub>(T)/R<sub>25</sub></sub>	RESISTANCE (Ω)	ΔR/R (%)	α (%/K)	ΔT (K)	R <sub>min.</sub> (Ω)	R <sub>max.</sub> (Ω)
-40	34.972	1 643 693	10.803	- 6.85	1.58	1 466 123	1 821 262
-35	24.997	1 174 859	10.039	- 6.59	1.52	1 056 912	1 292 806
-30	18.095	850 461	9.3093	- 6.34	1.47	771 290	929 633
-25	13.256	623 018	8.6110	- 6.11	1.41	569 370	676 666
-20	9.8204	461 557	7.9424	- 5.89	1.35	424 898	498 216
-15	7.3528	345 583	7.3017	- 5.69	1.28	320 350	370 816
-10	5.5607	261 354	6.6871	- 5.49	1.22	243 877	278 831
-5	4.2455	199 536	6.0971	- 5.31	1.15	187 370	211 702
0	3.2705	153 714	5.5303	- 5.13	1.08	145 213	162 215
5	2.5410	119 427	4.9853	- 4.97	1.00	113 473	125 381
10	1.9902	93 541	4.4608	- 4.81	0.93	89 369	97 714
15	1.5709	73 832	3.9558	- 4.66	0.85	70 911	76 752
20	1.2490	58 703	3.4692	- 4.52	0.77	56 666	60 739
25	1.0000	47 000	3.0000	- 4.38	0.69	45 590	48 410
30	0.8060	37 881	3.2266	- 4.25	0.76	36 659	39 103
35	0.6537	30 726	3.4459	- 4.13	0.84	29 667	31 784
40	0.5335	25 073	3.6581	- 4.01	0.91	24 156	25 990
45	0.4378	20 579	3.8637	- 3.89	0.99	19 784	21 374
50	0.3614	16 984	4.0629	- 3.79	1.07	16 294	17 674
55	0.2998	14 092	4.2560	- 3.68	1.16	13 492	14 692
60	0.2500	11 751	4.4434	- 3.58	1.24	11 229	12 274
65	0.2095	9847.6	4.6252	- 3.49	1.33	9392.1	10 303
70	0.1764	8290.7	4.8017	- 3.40	1.41	7892.6	8688.8
75	0.1492	7011.4	4.9732	- 3.31	1.50	6662.7	7360.1
80	0.1267	5955.0	5.1397	- 3.22	1.59	5648.9	6261.1
85	0.1081	5078.7	5.3017	- 3.14	1.69	4809.5	5348.0
90	0.0925	4348.7	5.6204	- 3.07	1.83	4104.3	4593.1
95	0.0795	3737.8	5.9309	- 2.99	1.98	3516.1	3959.5
100	0.0686	3224.6	6.2335	- 2.92	2.14	3023.6	3425.7
105	0.0594	2791.8	6.5286	- 2.85	2.29	2609.5	2974.1
110	0.0516	2425.3	6.8163	- 2.78	2.45	2260.0	2590.7
115	0.0450	2113.9	7.0970	- 2.72	2.61	1963.9	2264.0
120	0.0393	1848.4	7.3709	- 2.65	2.78	1712.1	1984.6
125	0.0345	1621.2	7.6383	- 2.59	2.95	1497.3	1745.0



## Disclaimer

ALL PRODUCT, PRODUCT SPECIFICATIONS AND DATA ARE SUBJECT TO CHANGE WITHOUT NOTICE TO IMPROVE RELIABILITY, FUNCTION OR DESIGN OR OTHERWISE.

Vishay Intertechnology, Inc., its affiliates, agents, and employees, and all persons acting on its or their behalf (collectively, "Vishay"), disclaim any and all liability for any errors, inaccuracies or incompleteness contained in any datasheet or in any other disclosure relating to any product.

Vishay makes no warranty, representation or guarantee regarding the suitability of the products for any particular purpose or the continuing production of any product. To the maximum extent permitted by applicable law, Vishay disclaims (i) any and all liability arising out of the application or use of any product, (ii) any and all liability, including without limitation special, consequential or incidental damages, and (iii) any and all implied warranties, including warranties of fitness for particular purpose, non-infringement and merchantability.

Statements regarding the suitability of products for certain types of applications are based on Vishay's knowledge of typical requirements that are often placed on Vishay products in generic applications. Such statements are not binding statements about the suitability of products for a particular application. It is the customer's responsibility to validate that a particular product with the properties described in the product specification is suitable for use in a particular application. Parameters provided in datasheets and/or specifications may vary in different applications and performance may vary over time. All operating parameters, including typical parameters, must be validated for each customer application by the customer's technical experts. Product specifications do not expand or otherwise modify Vishay's terms and conditions of purchase, including but not limited to the warranty expressed therein.

Except as expressly indicated in writing, Vishay products are not designed for use in medical, life-saving, or life-sustaining applications or for any other application in which the failure of the Vishay product could result in personal injury or death. Customers using or selling Vishay products not expressly indicated for use in such applications do so at their own risk. Please contact authorized Vishay personnel to obtain written terms and conditions regarding products designed for such applications.

No license, express or implied, by estoppel or otherwise, to any intellectual property rights is granted by this document or by any conduct of Vishay. Product names and markings noted herein may be trademarks of their respective owners.

## Material Category Policy

**Vishay Intertechnology, Inc. hereby certifies that all its products that are identified as RoHS-Compliant fulfill the definitions and restrictions defined under Directive 2011/65/EU of The European Parliament and of the Council of June 8, 2011 on the restriction of the use of certain hazardous substances in electrical and electronic equipment (EEE) - recast, unless otherwise specified as non-compliant.**

**Please note that some Vishay documentation may still make reference to RoHS Directive 2002/95/EC. We confirm that all the products identified as being compliant to Directive 2002/95/EC conform to Directive 2011/65/EU.**

**Vishay Intertechnology, Inc. hereby certifies that all its products that are identified as Halogen-Free follow Halogen-Free requirements as per JEDEC JS709A standards. Please note that some Vishay documentation may still make reference to the IEC 61249-2-21 definition. We confirm that all the products identified as being compliant to IEC 61249-2-21 conform to JEDEC JS709A standards.**



Компания «ЭлектроПласт» предлагает заключение долгосрочных отношений при поставках импортных электронных компонентов на взаимовыгодных условиях!

Наши преимущества:

- Оперативные поставки широкого спектра электронных компонентов отечественного и импортного производства напрямую от производителей и с крупнейших мировых складов;
- Поставка более 17-ти миллионов наименований электронных компонентов;
- Поставка сложных, дефицитных, либо снятых с производства позиций;
- Оперативные сроки поставки под заказ (от 5 рабочих дней);
- Экспресс доставка в любую точку России;
- Техническая поддержка проекта, помощь в подборе аналогов, поставка прототипов;
- Система менеджмента качества сертифицирована по Международному стандарту ISO 9001;
- Лицензия ФСБ на осуществление работ с использованием сведений, составляющих государственную тайну;
- Поставка специализированных компонентов (Xilinx, Altera, Analog Devices, Intersil, Interpoint, Microsemi, Aeroflex, Peregrine, Syfer, Eurofarad, Texas Instrument, Miteq, Cobham, E2V, MA-COM, Hittite, Mini-Circuits, General Dynamics и др.);

Помимо этого, одним из направлений компании «ЭлектроПласт» является направление «Источники питания». Мы предлагаем Вам помощь Конструкторского отдела:

- Подбор оптимального решения, техническое обоснование при выборе компонента;
- Подбор аналогов;
- Консультации по применению компонента;
- Поставка образцов и прототипов;
- Техническая поддержка проекта;
- Защита от снятия компонента с производства.



#### Как с нами связаться

**Телефон:** 8 (812) 309 58 32 (многоканальный)

**Факс:** 8 (812) 320-02-42

**Электронная почта:** [org@eplast1.ru](mailto:org@eplast1.ru)

**Адрес:** 198099, г. Санкт-Петербург, ул. Калинина, дом 2, корпус 4, литера А.