

## Product Specification

### 2km 100G CWDM4 QSFP28 Optical Transceiver Module FTLC1155RGPL

#### PRODUCT FEATURES

- Hot-pluggable QSFP28 form factor
- Supports 103.1Gb/s aggregate bit rate
- Power dissipation < 3.5W
- RoHS-6 compliant
- Commercial case temperature range of 0°C to +70°C
- Adaptive CTLE
- Single 3.3V power supply
- Loss budget of 5 dB on up to 2 km of Single Mode Fiber (SMF) [with KR4 FEC]
- 4x25Gb/s CWDM transmitter
- 4x25G retimed electrical interface
- Duplex LC receptacles
- I2C management interface



#### APPLICATIONS

- 100G CWDM4 applications with FEC

Finisar's FTLC1155RGPL QSFP28 transceiver modules are designed for use in 100 Gigabit Ethernet links on up to 2 km of single mode fiber. They are compliant with the QSFP28 MSA<sup>1</sup>, CWDM4 MSA<sup>2</sup> and portions of IEEE P802.3bm<sup>3</sup>. Digital diagnostic functions are available via the I2C interface, as specified by the QSFP28 MSA and Finisar Application Notes AN-2153<sup>4</sup> and AN-2154<sup>5</sup>. The optical transceiver is compliant per the RoHS-6 Directive 2011/65/EU<sup>6</sup>. See Finisar Application Note AN-2038<sup>7</sup> for more details.

#### PRODUCT SELECTION

### FTLC1155RGPL

- 5: Gen 2
- R: Ethernet maximum bit rate (103.1 Gb/s)
- G: 4x25G CWDM optical architecture
- P: Pull-tab release
- L: LC straight receptacles

## I. Pin Descriptions

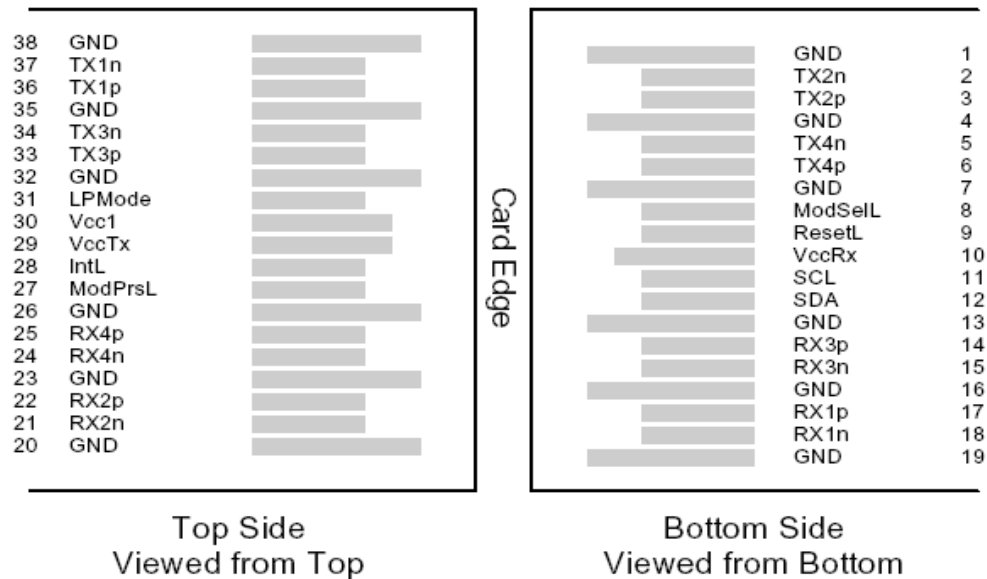

Figure 1 – QSFP28-compliant 38-pin connector (per SFF-8679)

Pin	Symbol	Name/Description	Notes
1	GND	Ground	1
2	Tx2n	Transmitter Inverted Data Input	
3	Tx2p	Transmitter Non-Inverted Data Input	
4	GND	Ground	1
5	Tx4n	Transmitter Inverted Data Input	
6	Tx4p	Transmitter Non-Inverted Data Input	
7	GND	Ground	1
8	ModSelL	Module Select	
9	ResetL	Module Reset	
10	Vcc Rx	+3.3 V Power supply receiver	
11	SCL	2-wire serial interface clock	
12	SDA	2-wire serial interface data	
13	GND	Ground	1
14	Rx3p	Receiver Non-Inverted Data Output	
15	Rx3n	Receiver Inverted Data Output	
16	GND	Ground	1
17	Rx1p	Receiver Non-Inverted Data Output	
18	Rx1n	Receiver Inverted Data Output	
19	GND	Ground	1
20	GND	Ground	1
21	Rx2n	Receiver Inverted Data Output	
22	Rx2p	Receiver Non-Inverted Data Output	
23	GND	Ground	1
24	Rx4n	Receiver Inverted Data Output	
25	Rx4p	Receiver Non-Inverted Data Output	
26	GND	Ground	1
27	ModPrsL	Module Present	
28	IntL	Interrupt	2
29	Vcc Tx	+3.3 V Power supply transmitter	
30	Vcc1	+3.3 V Power Supply	

31	LPMODE	Low Power Mode	2
32	GND	Ground	1
33	Tx3p	Transmitter Non-Inverted Data Input	
34	Tx3n	Transmitter Inverted Data Input	
35	GND	Ground	1
36	Tx1p	Transmitter Non-Inverted Data Input	
37	Tx1n	Transmitter Inverted Data Input	
38	GND	Ground	1

**Notes**

1. Circuit ground is internally isolated from chassis ground.
2. The IntL pin (“Interrupt Low”, pin 28) can be configured to act as an Rx\_LOS output;  
The LPMODE pin (“Low Power Mode”, pin 31) can be configured to act as an input for Tx\_Disable;  
See Finisar Application Note AN-2038<sup>8</sup> for more details.

**II. Absolute Maximum Ratings**

Module performance is not guaranteed beyond the operating range (see Section VI).  
Exceeding the limits below may damage the transceiver module permanently.

Parameter	Symbol	Min	Typ	Max	Unit	Ref.
Maximum Supply Voltage	V <sub>CC</sub>	-0.5		3.6	V	
Storage Temperature	T <sub>S</sub>	-40		+85	°C	
Case Operating Temperature	T <sub>OP</sub>	0		+70	°C	
Relative Humidity	RH	15		85	%	1
Receiver Damage Threshold, per Lane	P <sub>Rdmg</sub>	3.5			dBm	

**Notes:**

1. Non-condensing.

**III. Electrical Characteristics (EOL, T<sub>OP</sub> = 0 to +70 °C, V<sub>CC</sub> = 3.135 to 3.465 Volts)**

Parameter	Symbol	Min	Typ	Max	Unit	Ref.
Supply Voltage	V <sub>CC</sub>	3.135		3.465	V	
Supply Current	I <sub>CC</sub>			1.12	A	
Module total power	P			3.5	W	1
<b>Transmitter</b>						
Signaling rate per lane		25.78125 ± 100 ppm			GBd	
Differential data input swing per lane	V <sub>in,pp</sub>			900	mV	
Differential input return loss (min)	RL <sub>d</sub> (f)	9.5 – 0.37f, 0.01 ≤ f < 8 4.75 – 7.4log <sub>10</sub> (f/14), 8 ≤ f < 19			dB	
Differential to common mode input return loss (min)	RL <sub>dc</sub> (f)	22-20(f/25.78), 0.01 ≤ f < 12.89 15-6(f/25.78), 12.89 ≤ f < 19			dB	
Differential termination mismatch				10	%	
<b>Stressed input parameters</b>						
Eye width			0.46		UI	
Applied pk-pk sinusoidal jitter		Per IEEE 802.3bm Table 88-13				
Eye height			95		mV	
DC common mode voltage		-350		2850	mV	
<b>Receiver</b>						
Signaling rate per lane		25.78125 ± 100 ppm			GBd	
Differential data output swing	V <sub>out,pp</sub>	100		400	mVpp	2
		300		600		
		400		800		
		600		1200		
Eye width		0.57			UI	

Vertical eye closure				5.5	dB	
Differential output return loss (min)	RLd(f)	9.5 – 0.37f, 0.01 ≤ f < 8 4.75 – 7.4log <sub>10</sub> (f/14), 8 ≤ f < 19			dB	
Common to differential mode conversion return loss (min)	RLdc(f)	22-20(f/25.78), 0.01 ≤ f < 12.89 15-6(f/25.78), 12.89 ≤ f < 19			dB	
Differential termination mismatch				10	%	
Transition time, 20% to 80%	t <sub>r</sub> , t <sub>f</sub>	12			ps	

**Notes:**

- Maximum total power value is specified across the full temperature and voltage range. Power consumption ≤ 3.5W when stabilized, but may be > 3.5W during locking acquisition.
- Output voltage is settable in 4 discrete ranges via I2C. Default range is Range 2 (400 – 800 mV).

**IV. Optical Characteristics (EOL, T<sub>OP</sub> = 0 to +70 °C, V<sub>CC</sub> = 3.135 to 3.465 Volts)**

Parameter	Symbol	Min	Typ	Max	Unit	Ref.
<b>Transmitter</b>						
Signaling Speed per Lane		25.78125 ± 100 ppm			GBd	1
Lane center wavelengths (range)		1264.5 – 1277.5 1284.5 – 1297.5 1304.5 – 1317.5 1324.5 – 1337.5			nm	
Transmit OMA per Lane	TxOMA1	-4		2.5	dBm	
Transmit OMA per Lane @TDP max	TxOMA2	-2			dBm	2
Transmit Average Power per Lane				2.5	dBm	8
Optical Extinction Ratio	ER	3.5			dB	
Transmitter and Dispersion Penalty per Lane	TDP			3	dB	3
Launch Power (OMA-TDP)	OMA-TDP	-5			dBm	
Sidemode Suppression ratio	SSR <sub>min</sub>	30			dB	
Average launch power of OFF transmitter, per lane				-30	dBm	
Transmitter Reflectance				-12	dB	
Transmitter eye mask definition {X1, X2, X3, Y1, Y2, Y3}		{0.31, 0.4, 0.45, 0.34, 0.38, 0.4}				4
<b>Receiver</b>						
Signaling Speed per Lane		25.78125 ± 100 ppm			GBd	5
Lane center wavelengths (range)		1264.5 – 1277.5 1284.5 – 1297.5 1304.5 – 1317.5 1324.5 – 1337.5			nm	
Receive Saturation (OMA) per Lane	R <sub>max</sub>	2.5			dBm	
Damage threshold per Lane		3.5			dBm	
Unstressed Receiver Sensitivity (OMA) per Lane	R <sub>xsens</sub>			-10	dBm	6
Stressed Receiver Sensitivity (OMA) per Lane	SRS			-7.3	dBm	7
Conditions of stressed receiver sensitivity test:						
Vertical Eye Closure Penalty	VECP	1.9			dB	
Stressed J2 Jitter	J2	0.33			UI	
Stressed J4 Jitter	J4	0.48			UI	
SRS eye mask definition {X1, X2, X3, Y1, Y2, Y3}		{0.39, 0.5, 0.5, 0.39, 0.39, 0.4}				
LOS De-Assert	LOS <sub>D</sub>			-11.6	dBm	
LOS Assert	LOS <sub>A</sub>	-24		-13.6	dBm	
LOS Hysteresis			1.5		dB	

**Notes:**

1. Transmitter consists of 4 lasers operating at 25.78Gb/s each.
2. At maximum TDP.
3. TDP value does not include MPI penalty.
4. Hit ratio of  $5 \times 10^{-5}$ , per IEEE.
5. Receiver consists of 4 photodetectors operating at 25.78Gb/s each.
6. Sensitivity is specified at  $5 \times 10^{-5}$  BER.
7. Measured with CWDM4 MSA<sup>2</sup> conformance test signal at TP3 for  $5 \times 10^{-5}$  BER.
8. Power value and power accuracy are with all channels on.

**V. General Specifications**

Parameter	Symbol	Min	Typ	Max	Units	Ref.
Bit Rate (all wavelengths combined)	BR			103.1	Gb/s	
Bit Error Ratio @25.78Gb/s	BER			$5 \times 10^{-5}$		1
<b>Maximum Supported Reach</b>						
Fiber Type						
SMF per G.652	LossBdgt			5	dB	2

**Notes:**

1. Tested with a  $2^{31} - 1$  PRBS.
2. This 5 dB loss budget includes 2.5dB optical coding gain from FEC on the host [RS-FEC (528,514) per Clause 91]. The maximum informative link length is 2km. The option to bypass RS-FEC is not supported. Loss budget may include up to 1dB MPI loss penalty with worse case Transmitter and worst case connector MPI.

**VI. Environmental Specifications**

Finisar FTLC1155RGPL QSFP28 transceivers have an operating case temperature range of 0°C to +70°C.

Parameter	Symbol	Min	Typ	Max	Units	Ref.
Case Operating Temperature	T <sub>op</sub>	0		+70	°C	
Storage Temperature	T <sub>sto</sub>	-40		+85	°C	

**VII. Regulatory Compliance**

Finisar FTLC1155RGPL QSFP28 transceivers are Class 1 Laser Products. They are certified per the following standards:

Feature	Agency	Standard
Laser Eye Safety	FDA/CDRH	CDRH 21 CFR 1040 and Laser Notice 50
	CSA	IEC60825-2:2004+A1+A2
	TüV	EN60825-1:2014 & EN60825-2:2006+A1+A2
Electrical Safety	CSA	IEC60950-1:2005+A1+A2
	TüV	EN60950-1:2006+A11+A1+A12+A2
	UL/CSA	CLASS 3862.13 & CLASS 3862.93

Copies of the referenced certificates are available at Finisar Corporation upon request.

### VIII. Digital Diagnostics Functions

FTLC1155RGPL QSFP28 transceivers support the I2C-based diagnostics interface specified by the SFF Committee<sup>1</sup>. See also Finisar Application Notes AN-2153<sup>4</sup> and AN-2154<sup>5</sup>.

### IX. Memory Contents

Per SFF-8665 Specification<sup>1</sup>. See Finisar Application Note AN-2154<sup>5</sup>. For CFP replacement applications, the transceiver module can be customized to enable Tx\_Disable and Rx\_LOS functions as alternate functions on LPMODE and IntL pins. See Finisar Application Note AN-2174<sup>8</sup> for more details.

### XI. Mechanical Specifications

Finisar FTLC1155RGPL transceivers are compatible with the QSFP28 Specification for pluggable form factor modules.

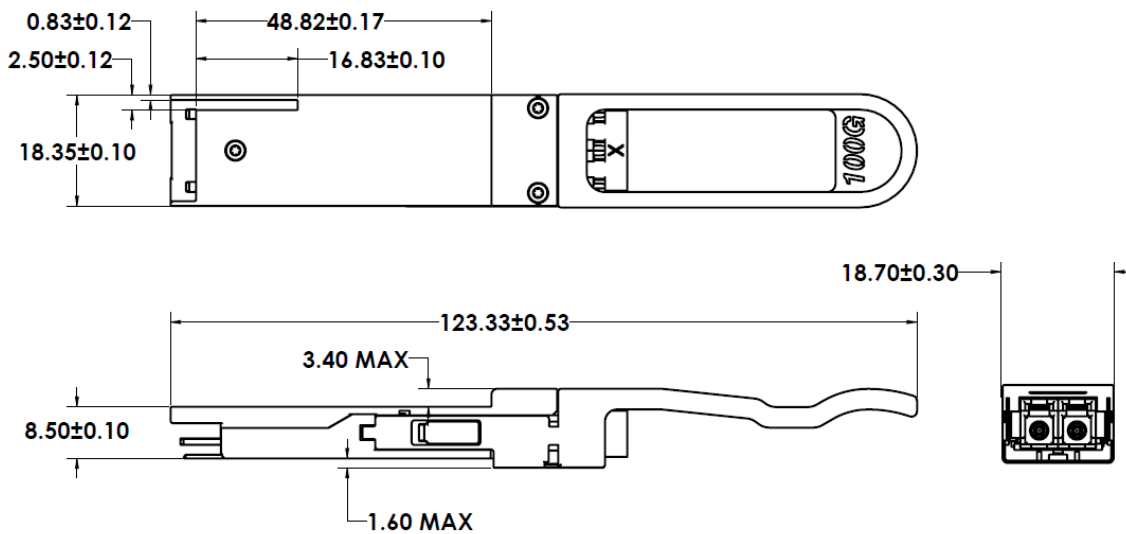

Figure 2. FTLC1155RGPL Mechanical Dimensions.

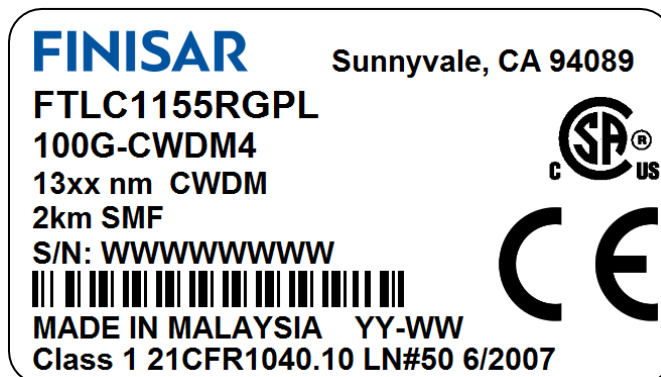

Figure 3. Product Label (Not to Scale)

## **XII. References**

1. SFF-8665: “QSFP+ 28Gb/s 4X Pluggable Transceiver Solution (QSFP28)”, Rev 1.9, June 29, 2015 and associated SFF documents referenced therein:
  - i. SFF-8661
  - ii. SFF-8679
  - iii. SFF-8636
  - iv. SFF-8662
  - v. SFF-8663
  - vi. SFF-8672
  - vii. SFF-8683
2. “100G CWDM4 MSA Technical Specifications: 2km Optical Specifications”, Rev. 1.1, November 23, 2015.
3. IEEE P802.3bm, CAUI-4 Interface.
4. Application Note AN-2153: Initialization, Finisar Corporation.
5. Application Note AN-2154: EEPROM Map, Finisar Corporation.
6. Directive 2011/65/EU of the European Parliament and of the Council, “on the restriction of the use of certain hazardous substances in electrical and electronic equipment,” July 1, 2011.
7. Application Note AN-2038: Finisar Implementation Of RoHS Compliant Transceivers, Finisar Corporation.
8. Application Note AN-2174: QSFP28 LR4 and QSFP28 CWDM4 – Tx\_Disable and Rx\_LOS Capability, Finisar Corporation.

### **For More Information:**

Finisar Corporation  
1389 Moffett Park Drive  
Sunnyvale, CA 94089-1133  
Tel. 1-408-548-1000  
Fax 1-408-541-6138  
[sales@finisar.com](mailto:sales@finisar.com)  
[www.finisar.com](http://www.finisar.com)



Компания «ЭлектроПласт» предлагает заключение долгосрочных отношений при поставках импортных электронных компонентов на взаимовыгодных условиях!

Наши преимущества:

- Оперативные поставки широкого спектра электронных компонентов отечественного и импортного производства напрямую от производителей и с крупнейших мировых складов;
- Поставка более 17-ти миллионов наименований электронных компонентов;
- Поставка сложных, дефицитных, либо снятых с производства позиций;
- Оперативные сроки поставки под заказ (от 5 рабочих дней);
- Экспресс доставка в любую точку России;
- Техническая поддержка проекта, помощь в подборе аналогов, поставка прототипов;
- Система менеджмента качества сертифицирована по Международному стандарту ISO 9001;
- Лицензия ФСБ на осуществление работ с использованием сведений, составляющих государственную тайну;
- Поставка специализированных компонентов (Xilinx, Altera, Analog Devices, Intersil, Interpoint, Microsemi, Aeroflex, Peregrine, Syfer, Eurofarad, Texas Instrument, Miteq, Cobham, E2V, MA-COM, Hittite, Mini-Circuits, General Dynamics и др.);

Помимо этого, одним из направлений компании «ЭлектроПласт» является направление «Источники питания». Мы предлагаем Вам помощь Конструкторского отдела:

- Подбор оптимального решения, техническое обоснование при выборе компонента;
- Подбор аналогов;
- Консультации по применению компонента;
- Поставка образцов и прототипов;
- Техническая поддержка проекта;
- Защита от снятия компонента с производства.



#### Как с нами связаться

**Телефон:** 8 (812) 309 58 32 (многоканальный)

**Факс:** 8 (812) 320-02-42

**Электронная почта:** [org@eplast1.ru](mailto:org@eplast1.ru)

**Адрес:** 198099, г. Санкт-Петербург, ул. Калинина, дом 2, корпус 4, литера А.