

Switched Capacitor Voltage Converter

FEATURES

- Charge Pump in 5-Pin SOT-23A Package
- >95% Voltage Conversion Efficiency
- Voltage Inversion and/or Doubling
- Low 38 μ A Quiescent Current
- Operates from +1.8V to +5.5V
- Up to 25mA Output Current
- Only Two External Capacitors Required
- Lower Power Version of TCM828

APPLICATIONS

- LCD Panel Bias
- Cellular Phones
- Pagers
- PDAs, Portable Dataloggers
- Battery-Powered Devices

PIN CONFIGURATION

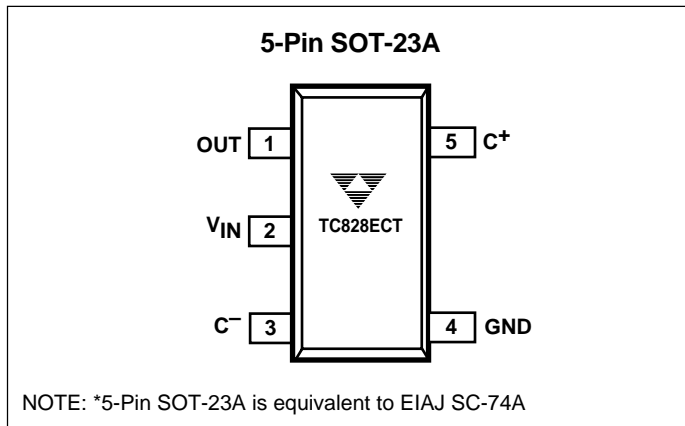

GENERAL DESCRIPTION

The TC828A is a CMOS “charge-pump” voltage converter in an ultra-small 5-Pin SOT-23A package. It can invert and/or double an input voltage that can range from +1.8V to +5.5V. Conversion efficiency is typically >95%, and switching frequency is 12KHz.

The external component requirement is only two capacitors (10 μ F nominal) for standard voltage inverter applications. With a few additional components a positive doubler can also be built. All other circuitry, including control, oscillator, power MOSFETs are integrated on-chip. Supply current is 38 μ A typically.

The TC828A is available in a 5-Pin SOT-23A surface mount package.

ORDERING INFORMATION

Part No.	Package	Temp. Range
TC828AECT	5-Pin SOT-23A	-40°C to +85°C

NOTE: 5-Pin SOT-23A is equivalent to EIAJ-SC74A.

TYPICAL OPERATING CIRCUIT

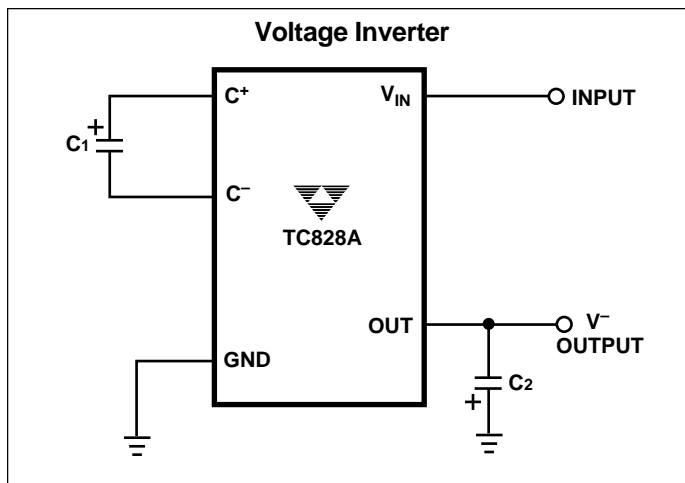

TC828A

ABSOLUTE MAXIMUM RATINGS*

Input Voltage (V_{IN} to GND)	+6.0V, - 0.3V
Output Voltage (OUT to GND)	-6.0V, + 0.3V
Current at OUT Pin	50mA
Short-Circuit Duration – OUT to GND	Indefinite
Operating Temperature Range	- 40°C to +85°C

Power Dissipation ($T_A \leq 70^\circ\text{C}$)

5-Pin SOT-23A	240mW
Storage Temperature (Unbiased)	- 65°C to +150°C
Lead Temperature (Soldering, 10 sec)	+300°C

*This is a stress rating only and functional operation of the device at these or any other conditions above those indicated in the operational sections of the specifications is not implied. Exposure to absolute maximum rating conditions for extended periods may affect device reliability.

ELECTRICAL CHARACTERISTICS: $T_A = -40^\circ\text{C}$ to $+85^\circ\text{C}$, $V_{IN} = +5\text{V}$, $C_1 = C_2 = 10 \mu\text{F}$, unless otherwise noted. Typical values are at $T_A = +25^\circ\text{C}$.

Symbol	Parameter	Test Conditions	Min	Typ	Max	Unit
I_{DD}	Supply Current		—	38	80	μA
V^+	Minimum Supply Voltage	$R_{LOAD} = 1 \text{ K}\Omega$	1.8	—	—	V
V^+	Maximum Supply Voltage	$R_{LOAD} = 1 \text{ K}\Omega$	—	—	5.5	V
F_{OSC}	Oscillator Frequency		6	12	20	KHz
P_{EFF}	Power Efficiency	$R_{LOAD} = 1 \text{ K}\Omega$, $T_A = +25^\circ\text{C}$	—	96	—	%
V_{EFF}	Voltage Conversion Efficiency	$R_{LOAD} = \infty$	95	99.9	—	%
R_{OUT}	Output Resistance	$I_{OUT} = 5 \text{ mA}$, $T_A = +25^\circ\text{C}$ $T_A = -40^\circ\text{C}$ to $+85^\circ\text{C}$	—	25	50	Ω
			—	—	65	

NOTE: 1. Capacitor contribution is approximately 20% of the output impedance [ESR = $1 / \text{pump frequency} \times \text{capacitance}$].
2. All - 40°C to +85°C specifications above are guaranteed by design.

PIN DESCRIPTION

Pin No. (5-Pin SOT-23A)	Symbol	Description
1	OUT	Inverting charge pump output.
2	V_{IN}	Positive power supply input.
3	C_1^-	Commutation capacitor negative terminal.
4	GND	Ground.
5	C_1^+	Commutation capacitor positive terminal.

DETAILED DESCRIPTION

The TC828A charge pump converter inverts the voltage applied to the V_{IN} pin. Conversion consists of a two-phase operation (Figure 1). During the first phase, switches S2 and S4 are open and S1 and S3 are closed. During this time, C1 charges to the voltage on V_{IN} and load current is supplied from C2. During the second phase, S2 and S4 are closed, and S1 and S3 are open. This action connects C1 across C2, restoring charge to C2.

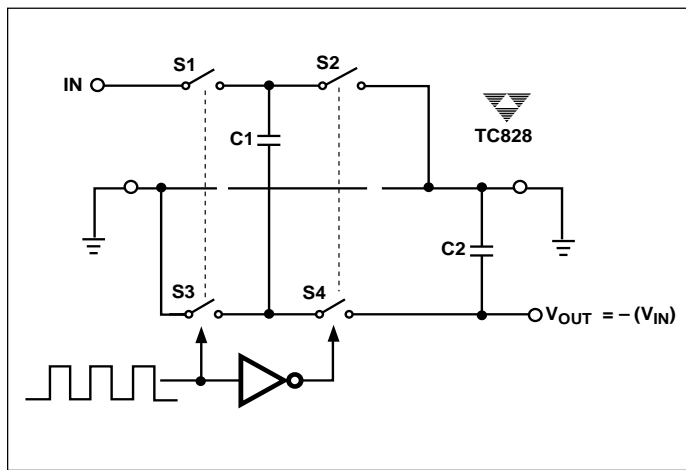

Figure 1. Ideal Switched Capacitor Charge Pump

APPLICATIONS INFORMATION

Output Voltage Considerations

The TC828A performs voltage conversion but does not provide *regulation*. The output voltage will droop in a linear manner with respect to load current. The value of this equivalent output resistance is approximately 25Ω nominal at +25°C and $V_{IN} = +5V$. V_{OUT} is approximately -5V at light loads, and droops according to the equation below:

$$V_{DROOP} = I_{OUT} \times R_{OUT}$$

$$V_{OUT} = -(V_{IN} - V_{DROOP})$$

Charge Pump Efficiency

The overall power efficiency of the charge pump is affected by four factors:

- (1) Losses from power consumed by the internal oscillator, switch drive, etc. (which vary with input voltage, temperature and oscillator frequency).
- (2) I^2R losses due to the on-resistance of the MOSFET switches on-board the charge pump.
- (3) Charge pump capacitor losses due to effective series resistance (ESR).

- (4) Losses that occur during charge transfer (from the commutation capacitor to the output capacitor) when a voltage difference between the two capacitors exists.

Most of the conversion losses are due to factors (2), (3) and (4) above. These losses are given by Equation 1.

$$P_{LOSS (2, 3, 4)} = I_{OUT}^2 \times R_{OUT}$$

$$\cong I_{OUT}^2 \times \left[\frac{1}{(f_{OSC}) C1} + 8R_{SWITCH} + 4ESR_{C1} + ESR_{C2} \right]$$

Equation 1.

The $1/(f_{OSC})(C1)$ term in Equation 1 is the effective output resistance of an ideal switched capacitor circuit (Figures 2a, 2b).

The losses in the circuit due to factor (4) above are also shown in Equation 2. The output voltage ripple is given by Equation 3.

$$P_{LOSS (4)} = \left[(0.5)(C1)(V_{IN}^2 - V_{OUT}^2) + (0.5)(C2)(V_{RIPPLE}^2 - 2V_{OUT}V_{RIPPLE}) \right] \times f_{OSC}$$

Equation 2.

$$V_{RIPPLE} = \frac{I_{OUT}}{(f_{OSC})(C2)} + 2(I_{OUT})(ESR_{C2})$$

Equation 3.

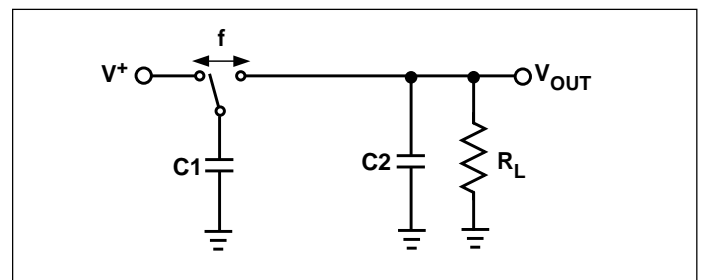

Figure 2a. Ideal Switched Capacitor Model

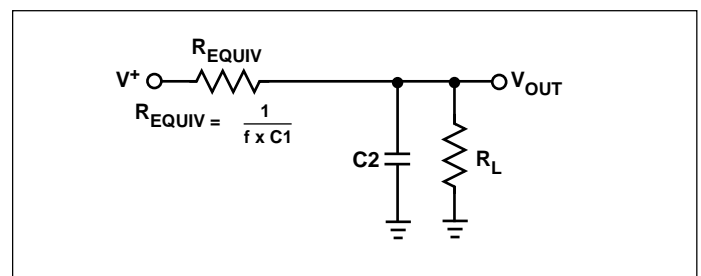

Figure 2b. Equivalent Output Resistance

TC828A

Capacitor Selection

In order to maintain the lowest output resistance and output ripple voltage, it is recommended that low ESR capacitors be used. Additionally, larger values of C1 will lower the output resistance and larger values of C2 will reduce output ripple. (See Equation 1(b)).

Table 1 shows various values of C1 and the corresponding output resistance values @ +25°C. It assumes a 0.1Ω ESR_{C1} and 2Ω R_{SW}. Table 2 shows the output voltage ripple for various values of C2. The V_{RIPPLE} values assume 10mA output load current and 0.1Ω ESR_{C2}.

Table 1. Output Resistance vs. C1 (ESR = 0.1Ω)

C1(μF)	R _{OUT} (Ω)
0.1	850
1	100
3.3	42
10	25
47	18.3
100	17.3

Table 2. Output Voltage Ripple vs. C2 (ESR = 0.1Ω) I_{OUT} 10mA

C2(μF)	V _{RIPPLE} (mV)
1	835
3.3	254
10	85
47	19.7
100	10.3

Input Supply Bypassing

The V_{IN} input should be capacitively bypassed to reduce AC impedance and minimize noise effects due to the switching internal to the device. The recommended capacitor depends on the configuration of the TC828A.

If the device is loaded from OUT to GND it is recommended that a large value capacitor (at least equal to C1) be connected from the input to GND. If the device is loaded from IN to OUT a small (0.1 μF) capacitor from IN to OUT is sufficient.

Voltage Inverter

The most common application for charge pump devices is the inverter (Figure 3). This application uses two external capacitors – C1 and C2 (plus a power supply bypass capacitor, if necessary). The output is equal to V_{IN} plus any voltage drops due to loading. Refer to Table 1 and Table 2 for capacitor selection.

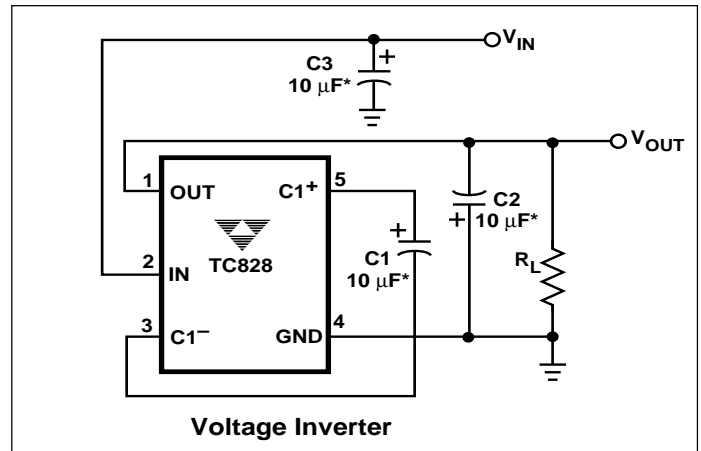

Figure 3. Test Circuit

Cascading Devices

Two or more TC828As can be cascaded to increase output voltage (Figure 4). If the output is lightly loaded, it will be close to (- 2 x V_{IN}) but will droop at least by R_{OUT} of the first device multiplied by the I_Q of the second. It can be seen that the output resistance rises rapidly for multiple cascaded devices. For large negative voltage requirements see the TC682 or TCM680 data sheets.

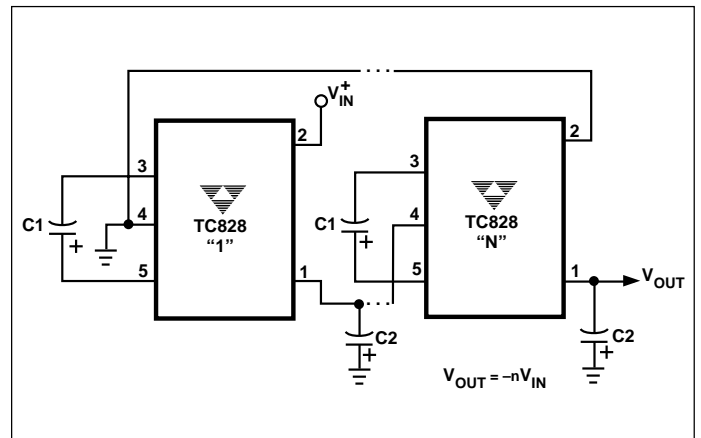

Figure 4. Cascading TC828As to Increase Output Voltage

Paralleling Devices

To reduce the value of R_{OUT}, multiple TC828As can be connected in parallel (Figure 5). The output resistance will be reduced by a factor of N where N is the number of TC828As. Each device will require its own pump capacitor (C1), but all devices may share one reservoir capacitor (C2). However, to preserve ripple performance the value of C2 should be scaled according to the number of paralleled TC828As.

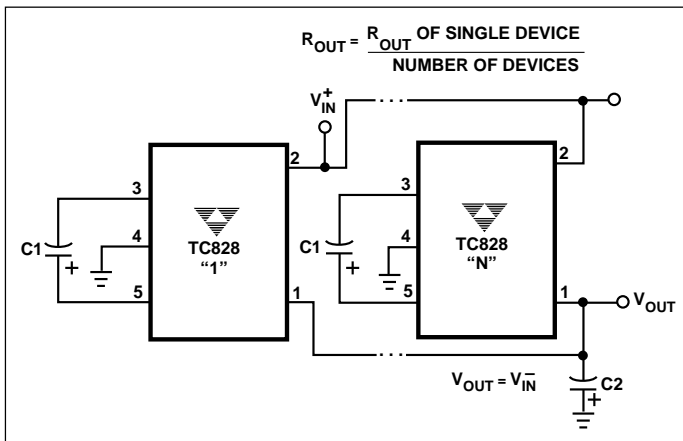

Figure 5. Paralleling TC828As to Reduce Output Resistance

Voltage Doubler/Inverter

Another common application of the TC828A is shown in Figure 6. This circuit performs two functions in combination. C1 and C2 form the standard inverter circuit described above. C3 and C4 plus the two diodes form the voltage doubler circuit. C1 and C3 are the pump capacitors and C2 and C4 are the reservoir capacitors. Because both sub-circuits rely on the same switches if either output is loaded, both will droop toward GND. Make sure that the total current drawn from both the outputs does not total more than 40 mA.

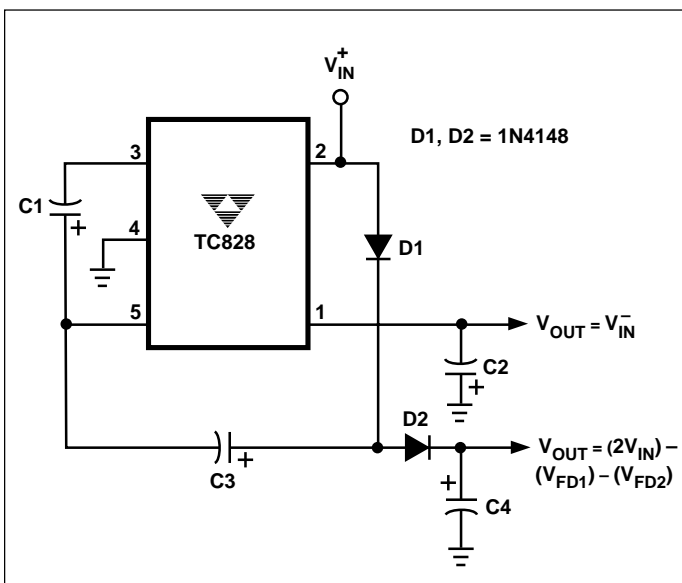

Figure 6. Combined Doubler and Inverter

Diode Protection for Heavy Loads

When heavy loads require the OUT pin to sink large currents being delivered by a positive source, diode protection may be needed. The OUT pin should not be allowed to be pulled above ground. This is accomplished by connecting a Schottky diode (1N5817) as shown in Figure 7.

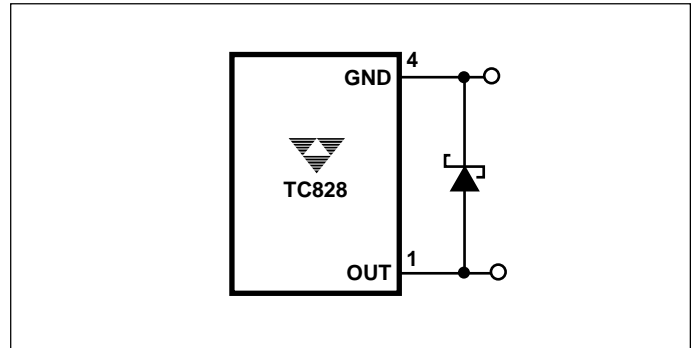

Figure 7. High V^- Load Current

Layout Considerations

As with any switching power supply circuit good layout practice is recommended. Mount components as close together as possible to minimize stray inductance and capacitance. Also use a large ground plane to minimize noise leakage into other circuitry.

TC828A

TYPICAL CHARACTERISTICS

Circuit of Figure 3, $V_{IN} = +5V$, $C1 = C2 = C3$, $T_A = +25^\circ C$, unless otherwise noted.

Output Resistance vs. Supply Voltage

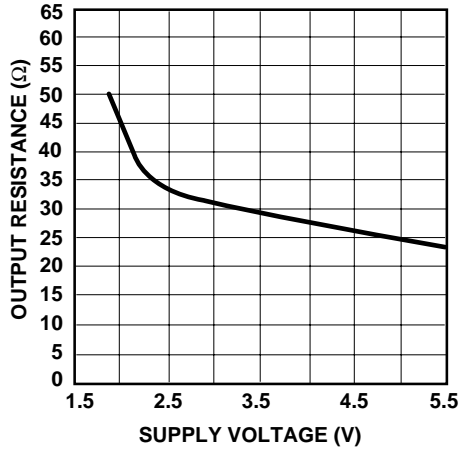

Output Resistance vs. Temperature

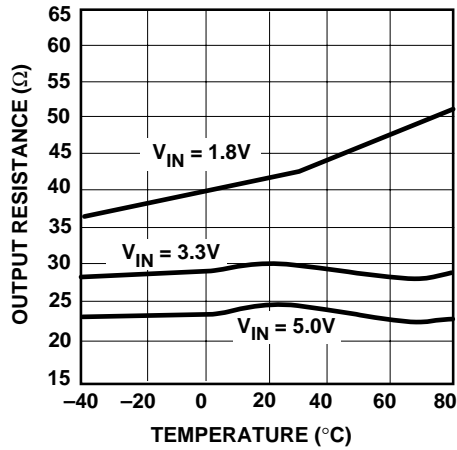

Output Current vs. Capacitance

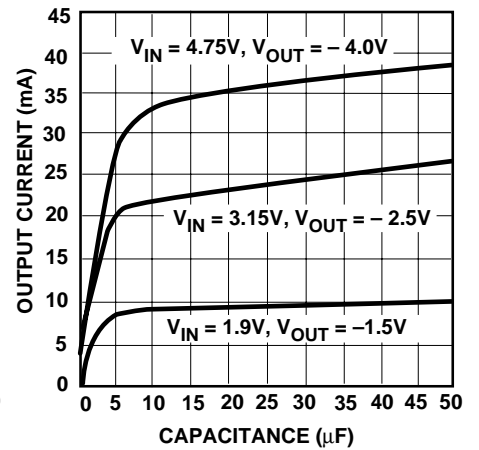

Output Voltage Ripple vs. Capacitance

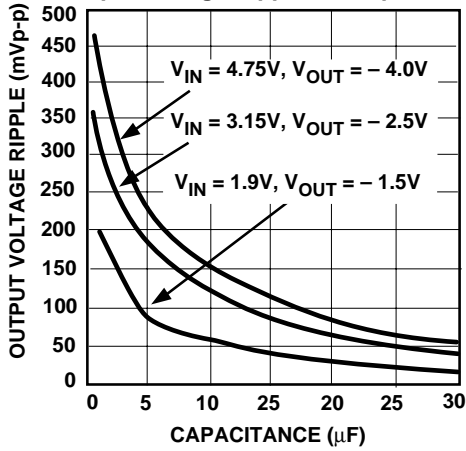

Supply Current vs. Supply Voltage

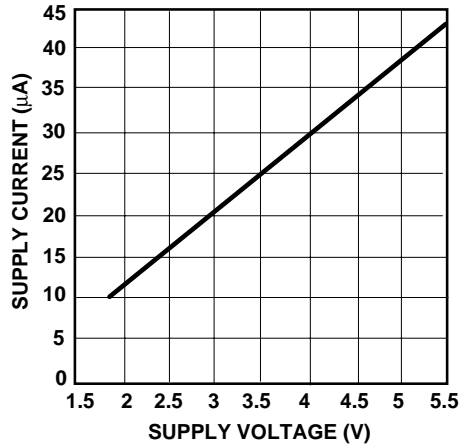

Pump Frequency vs. Temperature

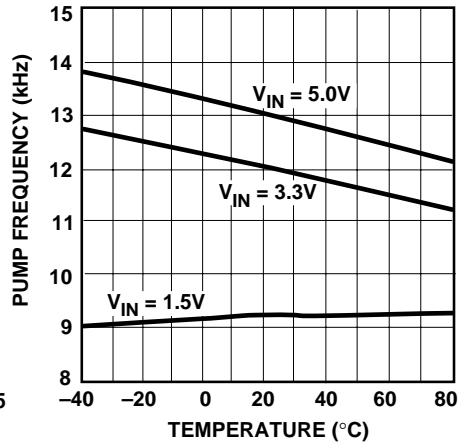

TYPICAL CHARACTERISTICS (Cont.)

Circuit of Figure 3, $V_{IN} = +5V$, $C1 = C2 = C3$, $T_A = +25^\circ C$, unless otherwise noted.

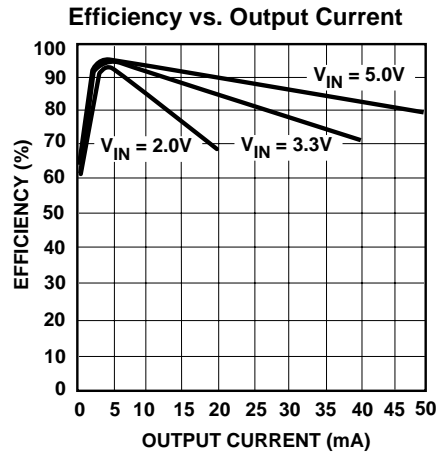
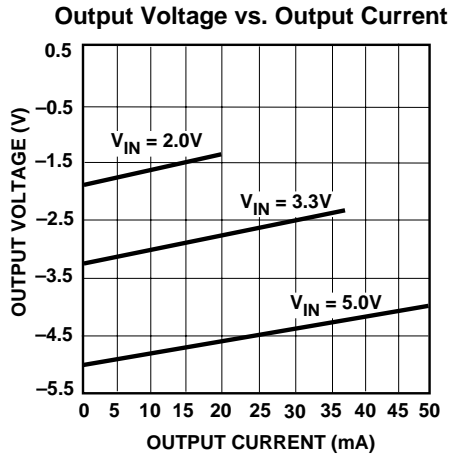

TAPING FORM

Component Taping Orientation for 5-Pin SOT-23A (EIAJ SC-74A) Devices

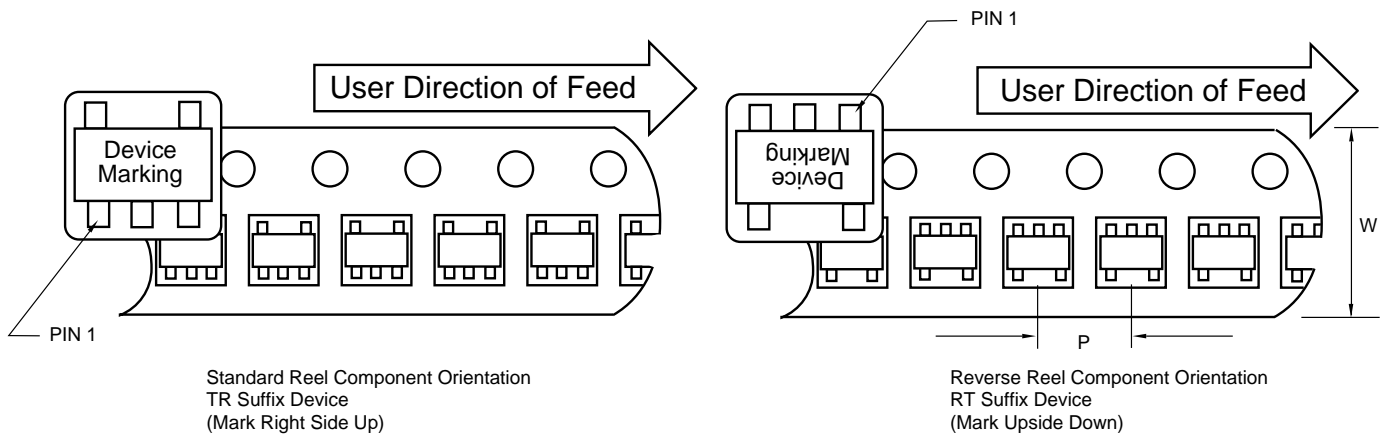

Carrier Tape, Number of Components Per Reel and Reel Size

Package	Carrier Width (W)	Pitch (P)	Part Per Full Reel	Reel Size
5-Pin SOT-23A	8 mm	4 mm	3000	7 in

TC828A

MARKING

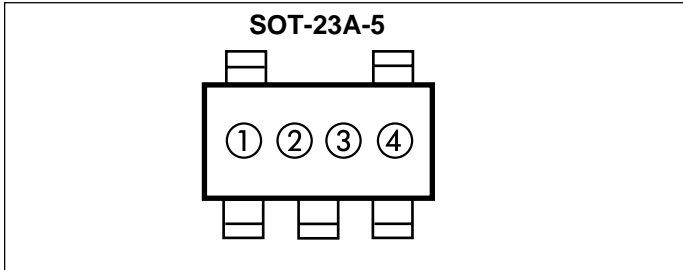

③ represents year and 2-month code

④ represents lot ID number

Part Numbers and Part Marking

① & ② = part number code + temperature range
(two-digit code).

TC828A	Code
TC828AECT	CC

ex: 828ECT = ①②③④⑤

PACKAGE DIMENSIONS

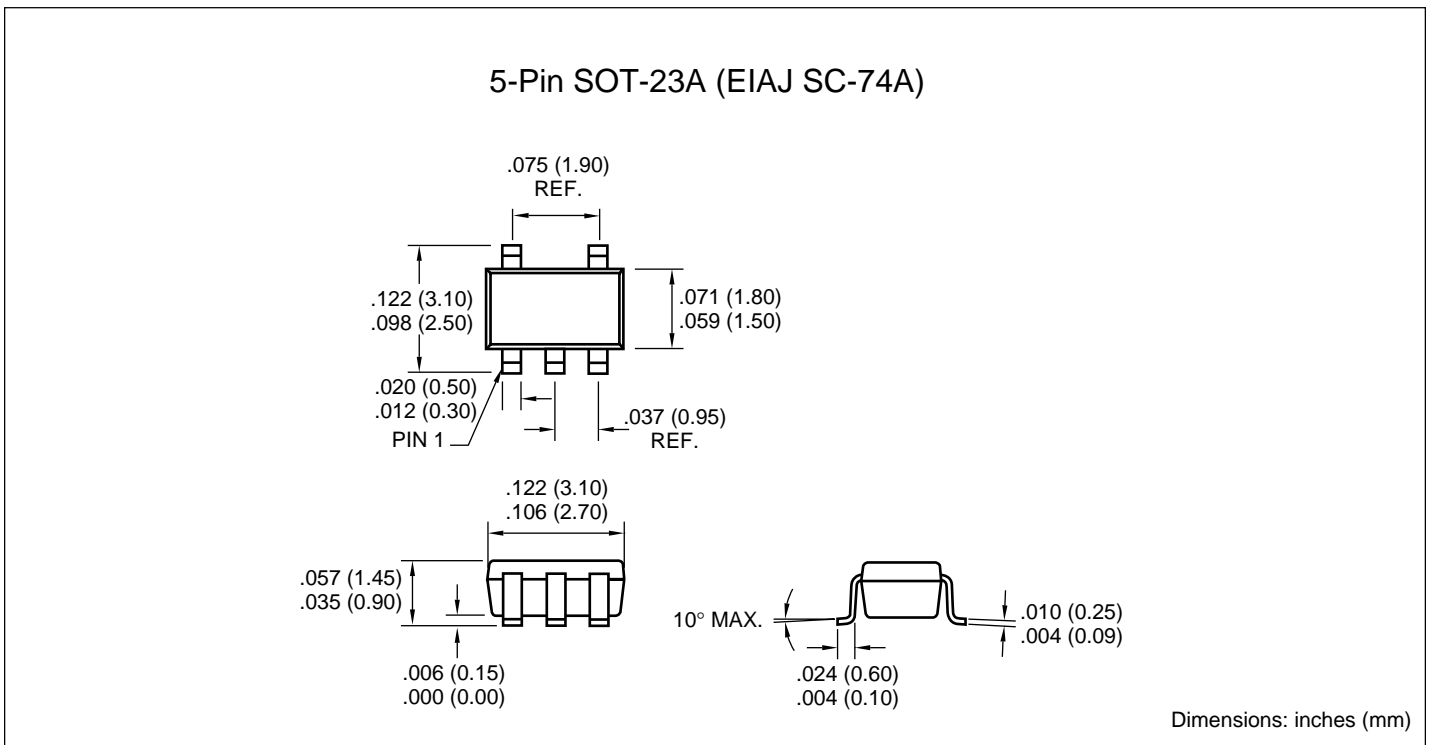

Sales Offices

TelCom Semiconductor, Inc.
1300 Terra Bella Avenue
P.O. Box 7267
Mountain View, CA 94039-7267
TEL: 650-968-9241
FAX: 650-967-1590
E-Mail: liter@telcom-semi.com

TelCom Semiconductor, GmbH
Lochamer Strasse 13
D-82152 Martinsried
Germany
TEL: (011) 49 89 895 6500
FAX: (011) 49 89 895 6502 2

TelCom Semiconductor H.K. Ltd.
10 Sam Chuk Street, Ground Floor
San Po Kong, Kowloon
Hong Kong
TEL: (011) 852-2350-7380
FAX: (011) 852-2354-9957



Компания «ЭлектроПласт» предлагает заключение долгосрочных отношений при поставках импортных электронных компонентов на взаимовыгодных условиях!

Наши преимущества:

- Оперативные поставки широкого спектра электронных компонентов отечественного и импортного производства напрямую от производителей и с крупнейших мировых складов;
- Поставка более 17-ти миллионов наименований электронных компонентов;
- Поставка сложных, дефицитных, либо снятых с производства позиций;
- Оперативные сроки поставки под заказ (от 5 рабочих дней);
- Экспресс доставка в любую точку России;
- Техническая поддержка проекта, помощь в подборе аналогов, поставка прототипов;
- Система менеджмента качества сертифицирована по Международному стандарту ISO 9001;
- Лицензия ФСБ на осуществление работ с использованием сведений, составляющих государственную тайну;
- Поставка специализированных компонентов (Xilinx, Altera, Analog Devices, Intersil, Interpoint, Microsemi, Aeroflex, Peregrine, Syfer, Eurofarad, Texas Instrument, Miteq, Cobham, E2V, MA-COM, Hittite, Mini-Circuits, General Dynamics и др.);

Помимо этого, одним из направлений компании «ЭлектроПласт» является направление «Источники питания». Мы предлагаем Вам помощь Конструкторского отдела:

- Подбор оптимального решения, техническое обоснование при выборе компонента;
- Подбор аналогов;
- Консультации по применению компонента;
- Поставка образцов и прототипов;
- Техническая поддержка проекта;
- Защита от снятия компонента с производства.



Как с нами связаться

Телефон: 8 (812) 309 58 32 (многоканальный)

Факс: 8 (812) 320-02-42

Электронная почта: org@eplast1.ru

Адрес: 198099, г. Санкт-Петербург, ул. Калинина, дом 2, корпус 4, литера А.