

# MAX1454 Evaluation System

## Evaluates: MAX1454

### General Description

The MAX1454 evaluation system (EV system) includes one MAX1454 master board and one MAX1454 evaluation kit (EV board). The MAX1454 daughter board system (DB system) includes one MAX1454 daughter board and one MAX1454 EV board. The EV system, when combined with the DB system, provides a proven design to evaluate up to 15 MAX1454 precision sensor signal conditioners. The EV system also includes Windows XP®, Windows Vista®, and Windows® 7-compatible software that provides a simple graphical user interface (GUI) for exercising the features of the IC. The master board includes interface circuitry to communicate between the IC and the host computer, circuitry to address each of the 15 devices in a fully loaded system, and circuitry to connect to the EV board in position 1. The EV board comes installed with a MAX1454AUE/V+ in a 16-pin TSSOP package. The daughter board includes circuitry and relays to connect to the EV board. Each position in the system, with the exception of position 1, requires a daughter board and an EV board. Therefore, to evaluate 15 MAX1454 devices, one EV system and 14 DB systems are required. Figure 1 shows a partially expanded system, for four positions.

### Features

- ◆ **USB Powered**
- ◆ **Evaluates Up to 15 MAX1454 Devices**
- ◆ **Daughter Board and EV Board Powered by the Master Board**
- ◆ **Sensor Socket on the EV Board**
- ◆ **On-Board ADC to Read the OUT Voltage of the MAX1454**
- ◆ **Windows XP-, Windows Vista-, and Windows 7-Compatible Software**
- ◆ **User-Friendly Graphical User Interface (GUI)**
- ◆ **Proven PCB Layout**
- ◆ **Fully Assembled and Tested**

Ordering Information appears at end of data sheet.

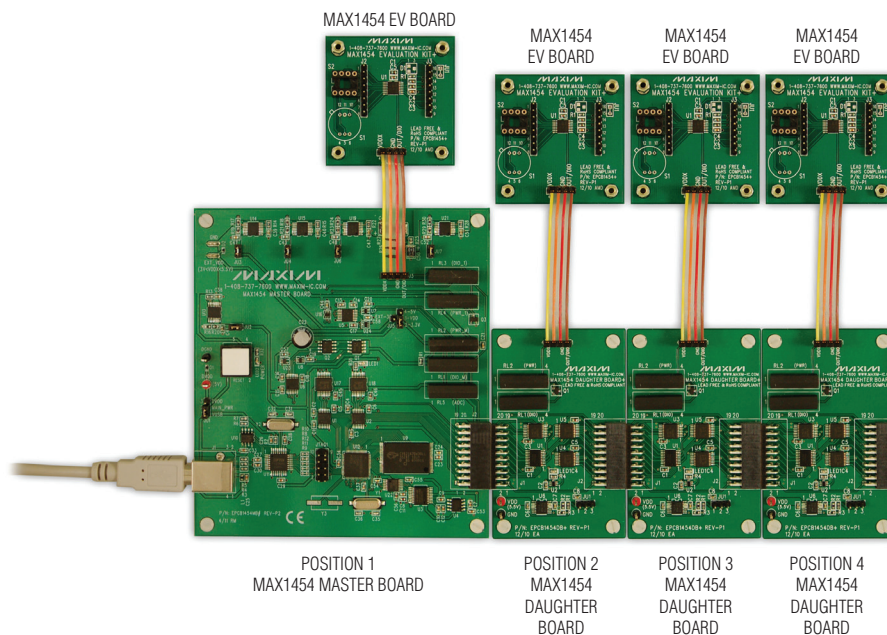

Figure 1. MAX1454 EV System (4-Position System, Expandable to 15 Positions)

Windows, Windows XP, and Windows Vista are registered trademarks of Microsoft Corp.

# MAX1454 Evaluation System

## Evaluates: MAX1454

### Component Lists

#### MAX1454 Master Board

DESIGNATION	QTY	DESCRIPTION
C1–C4, C13–C16, C19, C20, C21, C24, C41–C44, C48, C52, C54, C55, C58	21	10 $\mu$ F $\pm$ 20%, 6.3V X5R ceramic capacitors (0603) Murata GRM188R60J106M
C5, C6, C11, C17, C18, C45, C46, C56, C57	9	1 $\mu$ F 10%, 16V X5R ceramic capacitors (0603) Murata GRM188R61C105K
C7, C8, C9, C12, C23, C25–C29, C33, C34, C37, C53	14	0.1 $\mu$ F $\pm$ 10%, 16V X7R ceramic capacitors (0603) TDK C1608X7R1C104K
C10, C38, C39, C40, C47, C51	6	4.7 $\mu$ F $\pm$ 10%, 6.3V X5R ceramic capacitors (0603) Murata GRM188R60J475K
C22	1	220 $\mu$ F, 10V electrolytic capacitor Panasonic ECE-A1AKA221
C30	1	0.033 $\mu$ F $\pm$ 10%, 16V X5R ceramic capacitor (0603) Taiyo Yuden EMK107BJ333KA
C31, C32	2	22pF $\pm$ 5%, 50V C0G ceramic capacitors (0603) Murata GRM1885C1H220J
C35, C36	2	10pF $\pm$ 5%, 50V C0G ceramic capacitors (0603) Murata GRM1885C1H100J
C49, C50	2	47 $\mu$ F $\pm$ 20%, 6.3V capacitors (B1) SANYO 6TPC47MB
D1, D2	2	20V, 500mA Schottky diodes (SOD882)
DGND	1	Black test point
DVDD	1	Red test point
J1	1	USB type-B right-angle PC-mount receptacle
J2	1	2 x 10 right-angle female connector
J3	1	Single-row, 4-pin header
JTAG1	1	Dual-row, 10-pin (2 x 5) JTAG header
JU1	1	3-pin header
JU2, JU3, JU4, JU6, JU7	5	2-pin headers
JU5	1	4-pin header

DESIGNATION	QTY	DESCRIPTION
L1	1	Ferrite bead (0603) TDK MMZ1608R301A
L2	1	22 $\mu$ H, 0.11 $\Omega$ , 300mA inductor Coilcraft DS1608C-223ML
LED1, LED2	2	Red LEDs (0603) Panasonic LNJ208R8ARA
Q1, Q2	2	Power MOSFETs (8 SO) Fairchild FDS8958B
Q3	1	60V, 200mA n-channel MOSFET (3 SOT23)
R1	1	390k $\Omega$ $\pm$ 5% resistor (0603)
R2	1	470 $\Omega$ $\pm$ 5% resistor (0603)
R3, R4	2	27 $\Omega$ $\pm$ 5% resistors (0603)
R5	1	1.5k $\Omega$ $\pm$ 5% resistor (0603)
R6	1	2.2k $\Omega$ $\pm$ 5% resistor (0603)
R7	1	10k $\Omega$ $\pm$ 5% resistor (0603)
R8–R12	0	Not installed, resistors—short (PC trace) (0603)
R13, R14, R15, R22, R28	5	100k $\Omega$ $\pm$ 5% resistors (0603)
R16–R19, R24, R27, R30	7	10k $\Omega$ $\pm$ 1% resistors (0603)
R20	1	14k $\Omega$ $\pm$ 1% resistor (0603)
R23	1	16.5k $\Omega$ $\pm$ 1% resistor (0603)
R21, R29	2	30k $\Omega$ $\pm$ 1% resistors (0603)
R25	1	1M $\Omega$ $\pm$ 5% resistor (0603)
R26	1	34k $\Omega$ $\pm$ 1% resistor (0603)
R31, R32	2	1k $\Omega$ $\pm$ 5% resistors (0603)
R33	1	510 $\Omega$ $\pm$ 5% resistor (0603)
RESET	1	Normally closed pushbutton
RL1–RL5	5	Ultra-reed relays
U1, U2, U5	3	Level translators (14 TSSOP) Maxim MAX3379EEUD+
U3	1	16-bit ADC (20 SSOP) Maxim MAX1134BCAP+
U4	1	2.048V voltage reference (8 SO) Maxim MAX6126AASA21+
U6, U22	2	Level translators (14 TSSOP) Maxim MAX3390EEUD+

# MAX1454 Evaluation System

## Evaluates: MAX1454

### Component Lists (continued)

#### MAX1454 Master Board (continued)

DESIGNATION	QTY	DESCRIPTION
U7, U8, U16, U24	4	Logic inverters (SOT363)
U9	1	SRAM (48 TSOP)
U11	1	USB-to-UART converter (32 TQFP)
U10	1	93C46-type 3-wire EEPROM (8 SO)
U12	1	Microcontroller (68 QFN-EP) Maxim MAXQ2000-RAX+
U13, U14, U15, U19, U21	5	LDOs (16 TSSOP-EP) Maxim MAX1793EUE50+
U17, U18	2	4-bit comparators (16 SSOP)
U20	1	Step-up regulator (8 $\mu$ MAX <sup>®</sup> ) Maxim MAX1795EUA+
U23	1	Logic buffer (5 SC70)

DESIGNATION	QTY	DESCRIPTION
Y1	1	20MHz crystal Hong Kong X'tals SSM20000N1HK188F0-0
Y2	1	6MHz crystal Hong Kong X'tals SSL60000N1HK188F0-0
Y3	0	Not installed, crystal
—	4	0.250in x 0.625in 4-40 round nylon spacers
—	4	4-40 x 0.375in nylon machine screws
—	1	USB high-speed A-to-B cables 5ft (1.5m)
—	7	Shunts
—	1	PCB: MAX1454 MASTER BOARD

#### MAX1454 Daughter Board

DESIGNATION	QTY	DESCRIPTION
C1, C3, C4, C5	4	1 $\mu$ F $\pm$ 10%, 16V X7R ceramic capacitors (0603) Murata GRM188R71C105K
C2, C7, C8	3	10 $\mu$ F $\pm$ 20%, 6.3V X5R ceramic capacitors (0603) Murata GRM188R60J106M
C6	1	4.7 $\mu$ F $\pm$ 10%, 6.3V X5R ceramic capacitor (0603) Murata GRM188R60J475K
DVDD	1	Red test point
GND	1	Black test point
J1	1	2 x 10 right-angle male header
J2	1	2 x 10 right-angle female receptacle
J3	1	Single-row 4-pin header
JU1	1	3-pin header Sullins PEC36SAAN
LED1	1	Red LED (0603) Panasonic LNJ208R8ARA
Q1	1	60V, 200mA n-channel MOSFET (3 SOT23)

DESIGNATION	QTY	DESCRIPTION
R1	1	100k $\Omega$ $\pm$ 5% resistor (0603)
R2	1	30k $\Omega$ $\pm$ 1% resistor (0603)
R3	1	10k $\Omega$ $\pm$ 1% resistor (0603)
R4	1	1k $\Omega$ $\pm$ 5% resistor (0603)
RL1, RL2	2	Ultra-reed relays
U1	1	Logic buffer (20 TSSOP) Fairchild 74VHCT244AMTCX
U2	1	Logic inverter (6 SC70) NXP Semi 74LVC2G04GW
U3	1	4-bit adder (16 SSOP) NXP Semi 74HC283
U4, U5	2	4-bit comparators (16 SSOP) NXP Semi 74HCT85DB
U6	1	LDO (16 TSSOP-EP) Maxim MAX1793EUE18+
—	4	0.250in x 0.625in, 4-40 round nylon spacers
—	4	4-40 x 0.375in nylon machine screws
—	1	Shunts
—	1	PCB: MAX1454 DAUGHTER BOARD

$\mu$ MAX is a registered trademark of Maxim Integrated Products, Inc.

# MAX1454 Evaluation System

## Evaluates: MAX1454

### Component Lists (continued)

#### MAX1454 EV Board

DESIGNATION	QTY	DESCRIPTION
C1	1	1 $\mu$ F $\pm$ 10%, 16V X7R ceramic capacitor (0603) TDK C1608X7R1C105K
C2	0	Not installed, ceramic capacitor (0603)
C3	1	0.01 $\mu$ F $\pm$ 10%, 16V X7R ceramic capacitor (0603) Murata GRM188R71C103K
C4, C5	2	0.1 $\mu$ F $\pm$ 10%, 50V X7R ceramic capacitors (0603) TDK C1608X7R1H104K
D1	0	Not installed, Schottky diode
J1	1	Single-row 4-pin header
J2, J3	2	Single-row 8-pin headers
JU1	0	Not installed, 2-pin header—Short (PC trace)

DESIGNATION	QTY	DESCRIPTION
R1	0	Not installed, resistor—short (PC trace) (0603)
S1	0	Not installed, pressure sensor
S2	1	8-pin DIL header
U1	1	Precision sensor signal conditioner with overvoltage protection (16 TSSOP) Maxim MAX1454AUE/V+
—	1	3ft cable (4 pin)
—	4	0.250in x 0.625in, 4-40 Aluminum spacers
—	4	4-40 x 0.375in steel jack screws
—	1	PCB: MAX1454 EVALUATION KIT

### Component Suppliers

SUPPLIER	PHONE	WEBSITE
Coilcraft, Inc.	847-639-6400	www.coilcraft.com
Fairchild Semiconductor	888-522-5372	www.fairchildsemi.com
Hong Kong X'tals Ltd.	852-35112388	www.hongkongcrystal.com
Murata Electronics North America, Inc.	770-436-1300	www.murata-northamerica.com
Panasonic Corp.	800-344-2112	www.panasonic.com
SANYO Electric Co., Ltd.	619-661-6835	www.sanyo.com
Taiyo Yuden	800-348-2496	www.t-yuden.com
TDK Corp.	847-803-6100	www.component.tdk.com

**Note:** Indicate that you are using the MAX1454 when contacting these component suppliers.

### MAX1454 EV System Files

FILE	DESCRIPTION
INSTALL.EXE	Installs the EV system files on your computer
MAX1454.EXE	Application program
MAX1454_DLL.dll	MAX1454 DLL library file
CMODCOMM.dll	CMODCOMM library file
CDM20600.EXE	Installs the USB device driver
UNINSTALL.EXE	Uninstalls the EV system software
USB_Driver_Help_200.PDF	USB driver installation help file

### Quick Start

#### Required Equipment

- MAX1454 EV system (USB cable included)
- Windows XP, Windows Vista, or Windows 7 PC with a spare USB port

**Note:** In the following sections, software-related items are identified by bolding. Text in **bold** refers to items directly from the EV system software. Text in **bold and underlined** refers to items from the Windows operating system.

# MAX1454 Evaluation System

## Evaluates: MAX1454

### Procedure

The EV system is fully assembled and tested. Follow the steps below to verify board operation:

- 1) Visit [www.maxim-ic.com/evkitsoftware](http://www.maxim-ic.com/evkitsoftware) to download the latest version of the EV system software, 1454Rxx.ZIP. Save the EV system software to a temporary folder and uncompress the ZIP file.
- 2) Install the EV system software and USB driver on your computer by running the INSTALL.EXE program inside the temporary folder. The program files are copied to your PC and icons are created in the Windows **Start | Programs | Maxim EVKIT Software | MAX1454** menu. During software installation, some versions of Windows may show a warning message indicating that this software is from an unknown publisher. This is not an error condition and it is safe to proceed with installation. Administrator privileges are required to install the USB device driver on Windows.
- 3) Verify that all jumpers (JU1–JU7) are in their default positions, as shown in Table 1.
- 4) Connect the J3 connector of the master board to the J1 connector of the EV board with the provided flex cable.
- 5) Connect the USB cable from the PC to the master board. A Windows message appears when connecting the master board to the PC for the first time. Each version of Windows has a slightly different message. If you see a Windows message stating **ready to use**, then proceed to the next step. Otherwise, open the USB\_Driver\_Help\_200.PDF document in the Windows **Start | Programs | Maxim EVKIT Software | MAX1454** menu to verify that the USB driver was installed successfully.
- 6) Start the EV system software by opening its icon in the **Start | Programs | Maxim EVKIT Software | MAX1454** menu. The EV system software main window appears, as shown in Figure 2.
- 7) The EV system software automatically detects the MAX1454, and a  is displayed under **Device #1**.
- 8) In the **Output MUX** group box (Figure 2), select **VDD** from the **Signal** drop-down list.
- 9) Press the **Read Output** button and verify that the returned value that appears next to the button is approximately 2.5V.

**Table 1. Master Board Jumper Settings (JU1–JU7)**

JUMPER	SHUNT POSITION	DESCRIPTION
JU1	1-2*	EV system powered by the USB.
	2-3	Connect an external 5V supply to the DVDD and DGND connector.
JU2	1-2*	The on-board LDO (U13) provides 3V output to the EV system.
	Open	Disconnects the output of the on-board LDO (U13).
JU3	1-2*	The on-board LDO (U14) provides 2.5V output to the EV system.
	Open	Disconnects the output of the on-board LDO (U14).
JU4	1-2*	The on-board LDO (U15) provides 5V output to the EV system.
	Open	Disconnects the output of the on-board LDO (U15).
JU5	1-2	Selects 3.3V to connect to the VDDX of the active device.
	1-3	Selects EXT_VDD to connect to the VDDX of the active device.
	1-4*	Selects 5V to connect to the VDDX of the active device.
JU6	1-2*	The 3.3V output of the on-board LDO (U19) connects to pin 2 of jumper JU5.
	Open	Disconnects the output of the on-board LDO (U19).
JU7	1-2*	The 5V output of the on-board LDO (U21) connects to pin 1 of jumper JU5.
	2-3	Disconnects the output of the on-board LDO (U21).

\*Default position.

**Table 2. Daughter Board Jumper Settings (JU1)**

JUMPER	SHUNT POSITION	DESCRIPTION
JU1	1-2*	Daughter board powered by master board
	2-3	Connect an external 5.5V supply to the DVDD and GND connector

\*Default position.

# MAX1454 Evaluation System

## Evaluates: MAX1454

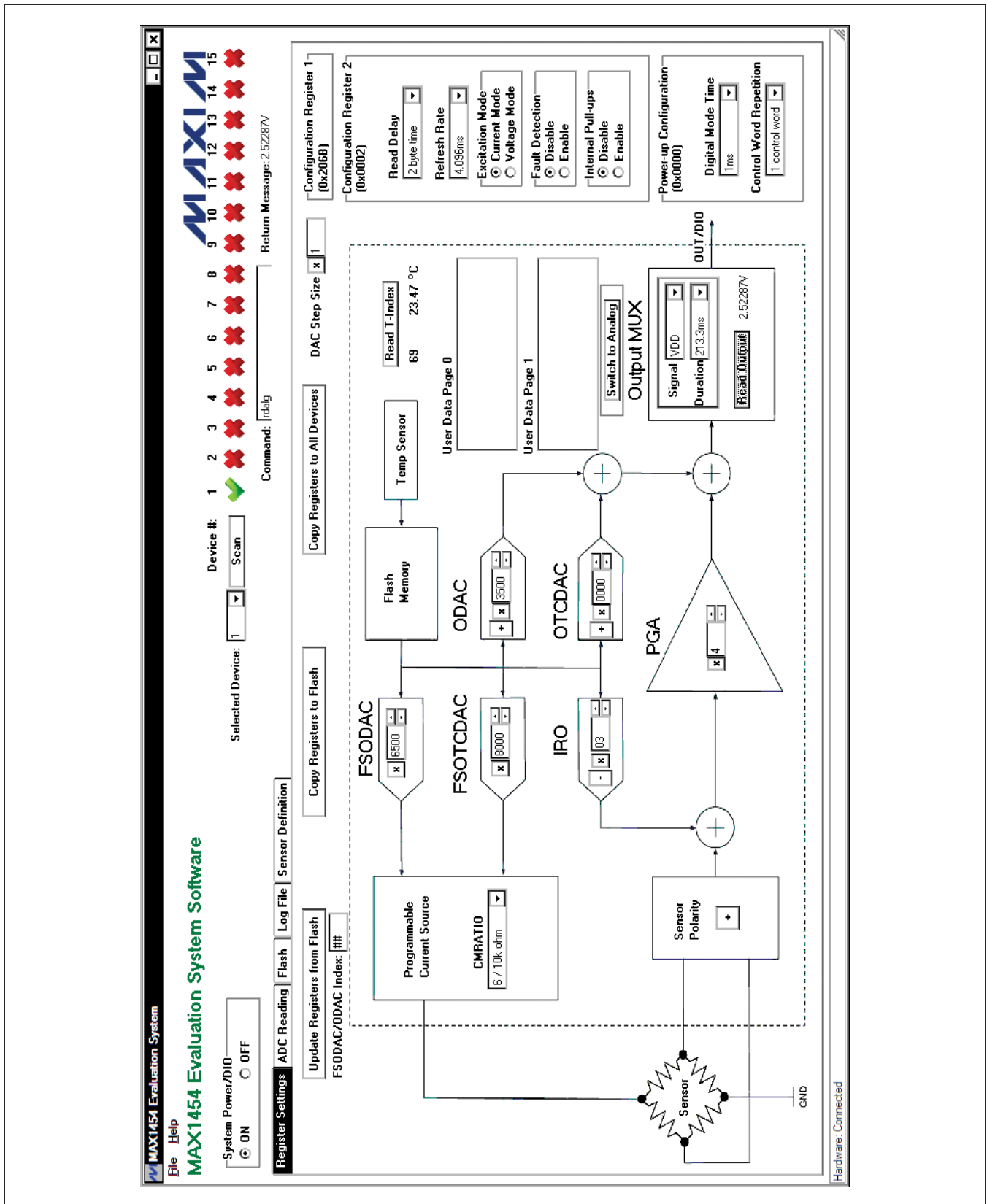

Figure 2. MAX1454 EV System Software Main Window (Register Settings Tab)





# MAX1454 Evaluation System

## Evaluates: MAX1454

### Detailed Description of Software

The MAX1454 EV system software (Figure 2) has all the functions to configure the MAX1454. When the software starts up, it scans the system and determines the number and position of operational MAX1454 present in the system. The first operational MAX1454 device is selected, powered up, and initialized to communicate in digital mode.

#### Scan

If the number or the positions of the operational devices on the system is changed, press the **Scan** button. After the **Scan** button is pressed, the EV system checks every position of the system (1 through 15) and identifies all positions with operating devices. If the device is present, the software displays a . Otherwise, the software displays a . The value in the **Selected Device** drop-down list identifies the active device-under-test (DUT).

#### System Power/DIO

To power off the system, press the **OFF** radio button in the **System Power/DIO** group box. Press the **ON** radio button to power up the system and the previously selected MAX1454 device. The selected device is initialized to communicate in digital mode.

#### Command

The **Command** edit box can be used to enter and execute any of the commands listed in the *Interpreter Definition* section. The **Return Message** is shown at the right of the **Command** edit box.

#### Register Settings Tab

After the software starts up and is connected to an active device selected in the **Selected Device** drop-down list, the default register values on the **Register Settings** tab sheet (Figure 2) are written in the active MAX1454 registers. Through the software, all parameters with a white window area can be edited by the user. The parameters can be edited by typing a new value in the edit box, selecting from a drop-down list, or by pressing a button. The revised value is automatically written to the corresponding MAX1454 register. All entries can be in hexadecimal or decimal format, except the **FSODAC/ODAC Index**, which must be in decimal format.

#### FSODAC, FSOTCDAC, ODAC, and OTCDAC

Values in each one of the **FSODAC**, **FSOTCDAC**, **ODAC**, and **OTCDAC** registers can be changed by its corresponding block, as explained in Figure 3. The sign bit does not apply to FSODAC and FSOTCDAC. The **Configuration Register 1** register (CONFIG1) value is updated automatically as the ODAC and OTCDAC sign

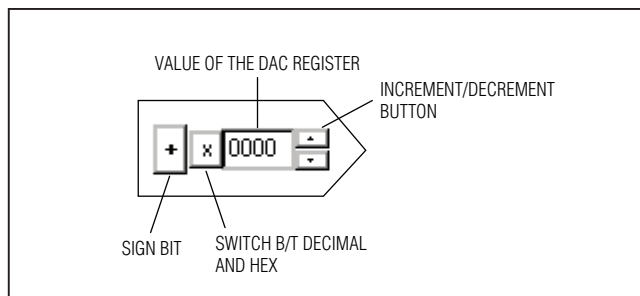

Figure 3. Register Controls

bits are changed. Values for these parameters can be selected to be in decimal or hexadecimal format. Refer to the MAX1454 IC data sheet for acceptable values.

#### IRO and PGA

The **IRO** and **PGA** control block set values of IRO (including IRO sign) and PGA values. **Configuration Register 1** (CONFIG1) value is updated automatically as these parameters are updated. Values for these parameters can be selected to be in decimal or hexadecimal format. Refer to the MAX1454 IC data sheet for acceptable values.

#### Sensor Polarity

This button corresponds to the **PGA Sign** bit in the **Configuration Register 1** (CONFIG1). To invert the polarity of the input signal, press to switch to negative. The **Configuration Register 1** (CONFIG1) value is updated automatically as the PGA sign bit is changed.

#### Functional Buttons

The **Update Registers from Flash** button updates all DAC and configuration registers from the flash memory of the active DUT. **FSODAC** and **ODAC** are updated from the lookup tables' locations pointed to by the **FSODAC/ODAC** index.

The **Copy Registers to Flash** button copies the register values shown on the GUI to the flash memory of the active DUT. All 176 locations of the FSODAC lookup table in the flash memory are filled with the value in the **FSODAC** register shown on the GUI. All 176 locations of the ODAC lookup table in the flash memory are filled with the value in the **ODAC** register shown on the GUI.

The **Copy Registers to All Devices** button does the same as the **Copy Registers to Flash**, except that action is performed on all operational DUTs in the system.

The **Read T-Index** button reads the internal temperature ADC and displays the return value in decimal format. The **T-Index** value is applied to the temperature conversion formula given in the MAX1454 IC data sheet and the resulting value (in °C) is displayed.

# MAX1454 Evaluation System

## Evaluates: MAX1454

### Programmable Current Source

The **CMRATIO** drop-down list in the **Programmable Current Source** box selects the desired current-mirror ratio for sensor excitation. It corresponds to the CMRATIO bits in the **Configuration Register 1**. Refer to the MAX1454 IC data sheet for details.

### Output MUX

Select the IC output signal from the **Signal** drop-down list within the **Output MUX** group box. Refer to Table 19 (ALOC definition) in the MAX1454 IC data sheet for more information about the available signals.

Select the duration for which the selected **Signal** remains available on the OUT/DIO pin from the **Duration** drop-down list. A readout device (e.g., voltmeter) is required to read the output.

Press the **Read Output** button to execute the read analog command that outputs the selected **Signal** onto the OUT/DIO pin.

### Switch to Analog

Press the **Switch to Analog** button to put the active DUT into fixed analog mode. In this mode, the device does not respond to commands. Press the **Scan** button to return to the digital programming mode.

### User Data

The general-purpose user data is displayed in the **User Data Page 0** and **User Data Page 1** memo boxes.

### Configuration Register 1 (CONFIG1)

The **Configuration Register 1** group box displays the current value of the CONFIG1 register.

### Configuration Register 2 (CONFIG2)

Items in this group box correspond to parameters in the CONFIG2 register. Refer to the MAX1454 IC data sheet for the definition of each parameter.

### Power-Up Configuration (PWRUPCFG)

Items in this group box correspond to parameters in the PWRUPCFG register. Refer to the MAX1454 IC data sheet for the definition of each parameter.

### ADC Reading Tab

The master board has an on-board 16-bit ADC device (MAX1134) to read the voltage of the OUT/DIO signal of the MAX1454. The **ADC Reading** tab sheet (Figure 4) has a **Scope** to display the output of the ADC. When the IC is operating in analog mode, check the **Auto Read OUT/DIO** checkbox to start the ADC conversion. The **Scope** receives new ADC values approximately every 300ms. If the IC is operating in digital mode, when the **Auto Read OUT/DIO** checkbox is checked the software triggers the **Read Output** button approximately every 300ms on the **Register Settings** tab sheet and displays the ADC return values on the **Scope**. The **Scope** displays the last 250 readings. Check the **Save Data to File** checkbox to start saving the ADC data along with

the message in the **Note** edit box to a file. The user is prompted for a file name.

### Flash Tab

The **Flash** tab sheet (Figure 5) is used to read or modify the contents of the internal flash memory of the active IC.

To read the flash memory, press the **Read from DUT Flash** button. The contents of the FSODAC and ODAC lookup tables are shown in the **FSODAC/ODAC Lookup Table**. The user can use the **DEC** button to switch the values in the **FSODAC/ODAC Lookup Table** between hexadecimal format and decimal format. The CONFIG1, CONFIG2, PWRUPCFG, OTCDAC, and the FSOTCDAC flash memory values are shown in the corresponding edit boxes at the right. The general-purpose user data is displayed in the **User Data Page 0** and **User Data Page 1** memo boxes.

Press the **Save Flash to File** button to save the contents of the flash to a file. The user is prompted for a file name.

There are two ways to modify the contents of the flash memory:

- 1) Manually change the contents on this tab sheet and press the **Write to DUT Flash** button to write the contents to the active device. The **Write to All Devices** button does the same thing except that it writes to all devices on the EV system.
- 2) Press the **Load Flash from File** button to copy the contents of a file to the flash memory of the active device. The user is prompted for a file name.

Press the **Read from File** button to update the contents of the **Flash** tab sheet from a file. The user is prompted for a file name.

### Log File Tab

In the **Log File** tab sheet (Figure 6), the **Command Log** memo box logs the interpreter commands (see the *Interpreter Definition* section) that were executed. When the user checks the **Save Command Log to File** checkbox, the software begins to record the commands to a file specified by the user until the **Save Command Log to File** checkbox is unchecked. To execute the commands from a file, press the **Execute Commands from File** button. To clear the **Command Log** memo box, press the **Clear Command Log** button.

The **Communication Log** memo box is very similar to the **Command Log** memo box. The difference is that the **Communication Log** logs both the executed interpreter commands and the return messages from the EV system. Check the **Save Communication Log to File** checkbox to start saving the commands and return messages to a file. Press the **Clear Communication Log** button to clear the **Communication Log**. Uncheck the **Save Communication Log to File** checkbox to stop saving the commands and return messages to a file.



# MAX1454 Evaluation System

## Evaluates: MAX1454

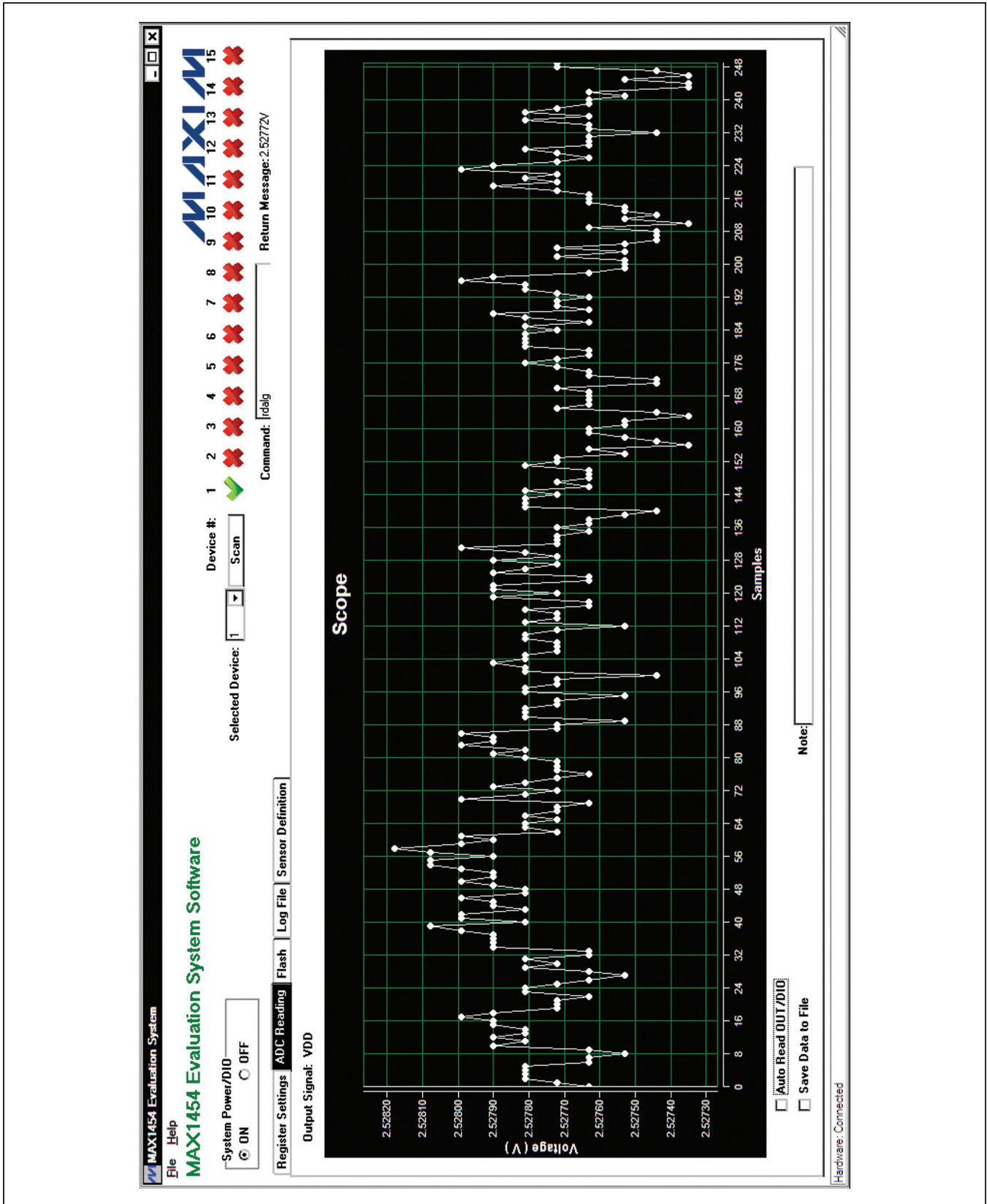

Figure 4. MAX1454 EV System Software Main Window (ADC Reading Tab)

# MAX1454 Evaluation System

## Evaluates: MAX1454

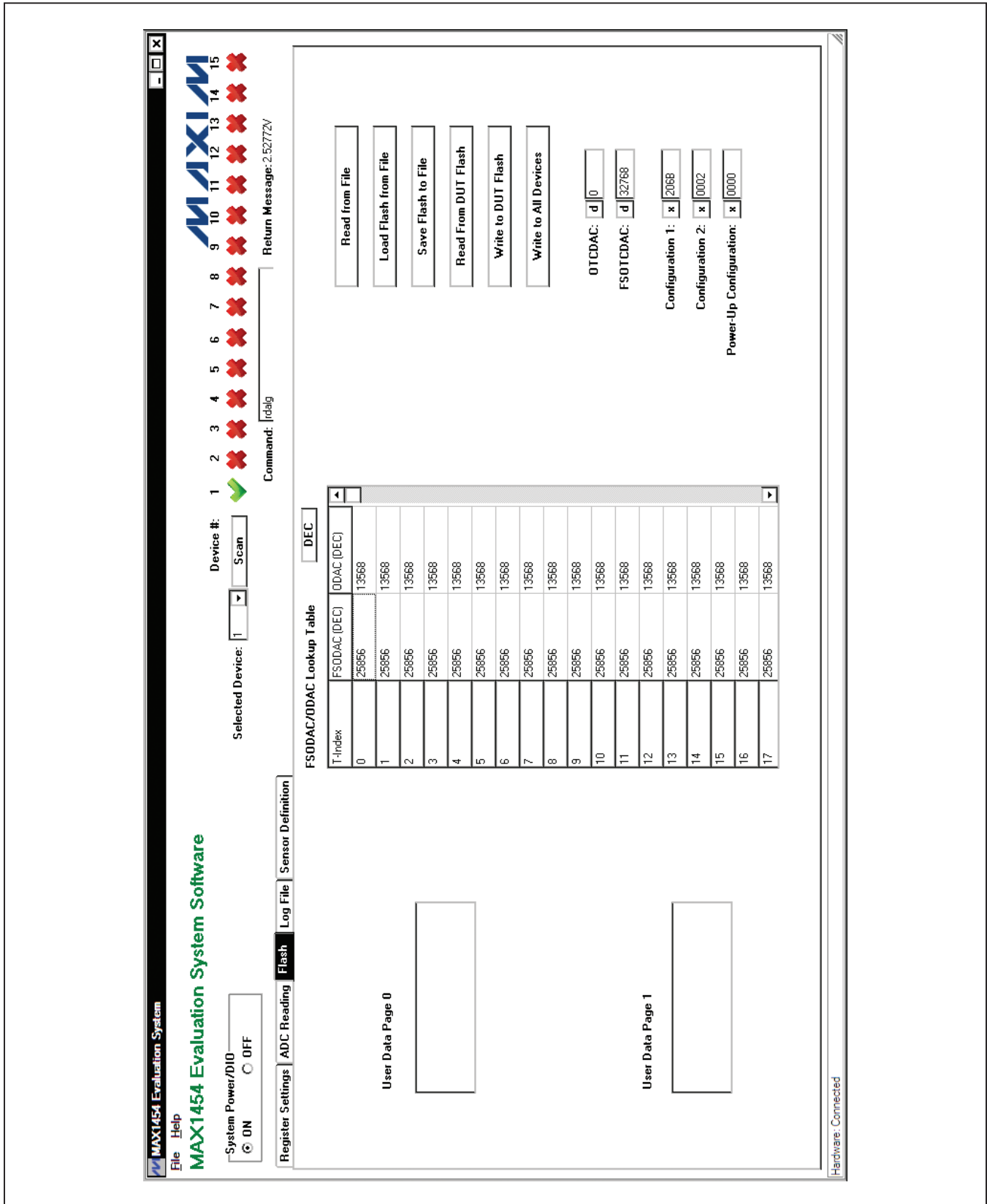

Figure 5. MAX1454 EV System Software Main Window (Flash Tab)

# MAX1454 Evaluation System

## Evaluates: MAX1454

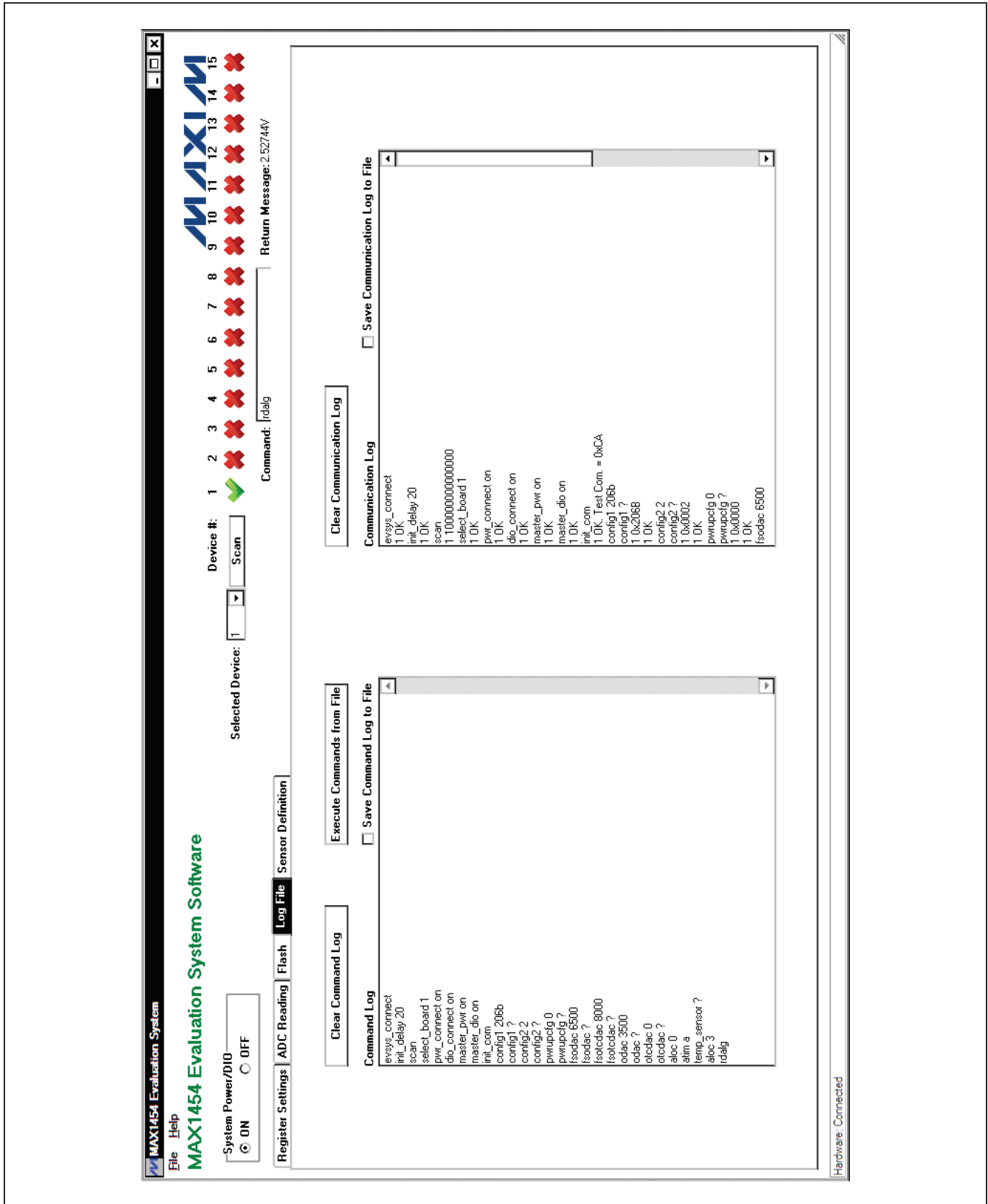

Figure 6. MAX1454 EV System Software Main Window (Log File Tab)

# MAX1454 Evaluation System

## Evaluates: MAX1454

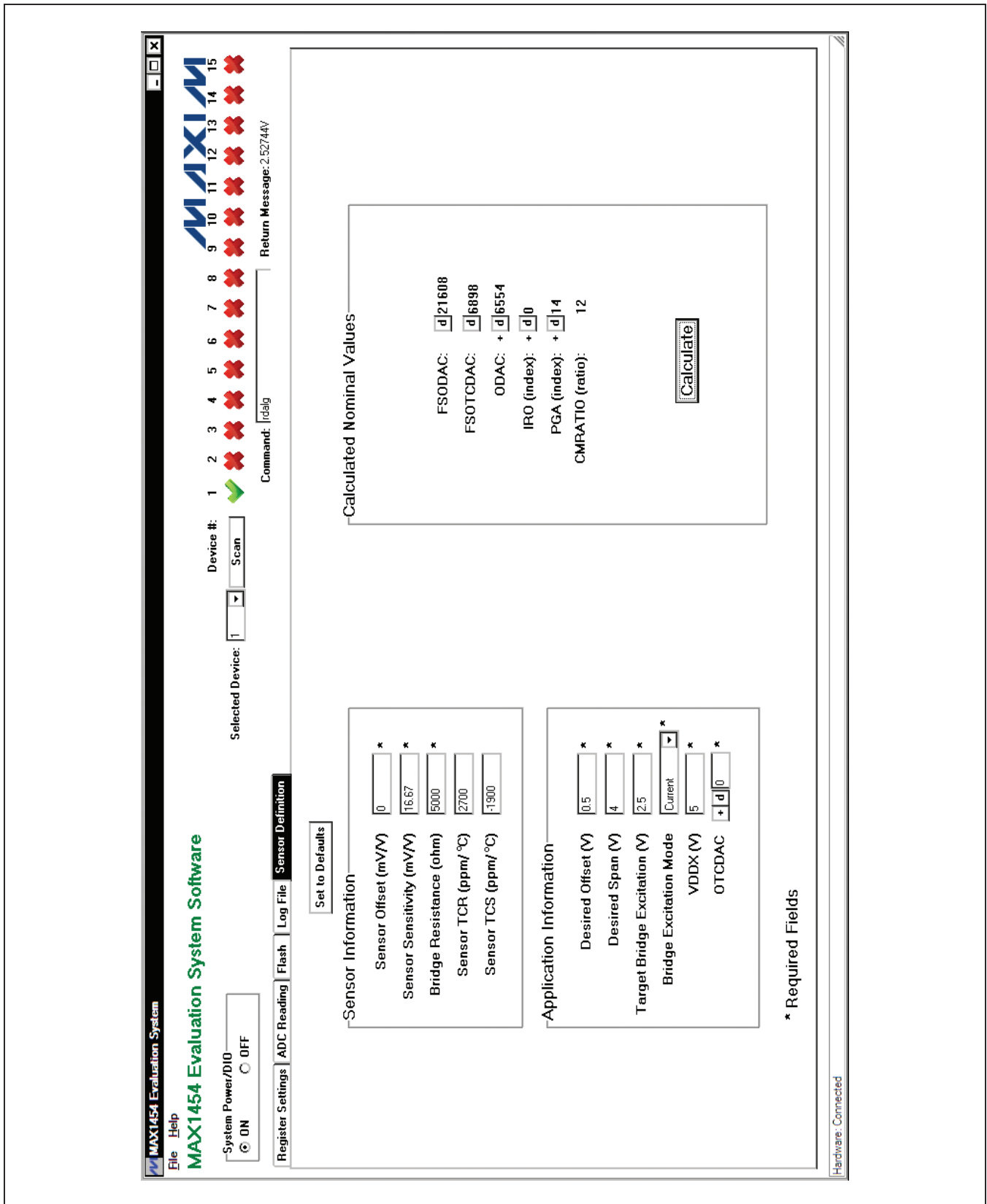

Figure 7. MAX1454 EV System Software Main Window (Sensor Definition Tab)

# MAX1454 Evaluation System

## Evaluates: MAX1454

### Sensor Definition Tab

On the **Sensor Definition** tab sheet (Figure 7), fill out the required information in the **Sensor Information** and **Application Information** group boxes, then press the **Calculate** button. The software calculates the appropriate FSODAC, ODAC, FSOTCDAC, IRO, PGA, and CMRATIO values based on the given information. The

calculated values are intended to bring the MAX1454 in the linear range and produce an output around the specified offset and span. The calculated values should be appropriate as starting values for the compensation process. In some instances, it may be required to adjust the PGA and/or DAC value. Sensor definition equations are listed in Table 3.

**Table 3. Sensor Definition Equations**

PARAMETER	EQUATION
FSODAC	<p>In Voltage Excitation Mode:</p> $FSODAC = 65535 \times \frac{VBDR}{VDDX}$ <p>In Current Excitation Mode:</p> $FSODAC = \frac{CMRATIO \times (FSOTCDAC \times VBDR + 3.5 \times 10^4) \times RBDR + 3.9321 \times 10^9 \times VBDR}{2 \times CMRATIO \times RBDR \times VDDX}$ <p>If the calculated FSODAC is negative, set FSODAC = 0.            If the calculated FSODAC is greater than 65535, set FSODAC = 65535.            CMRATIO: See CMRATIO equation            FSOTCDAC: See FSOTCDAC equation            VBDR (V) is the Target Bridge Excitation voltage specified by user            RBDR (<math>\Omega</math>) is the sensor Bridge Resistance specified by user            VDDX (V) is the External Supply Voltage specified by user</p>
FSOTCDAC	<p>In Voltage Excitation Mode:</p> $FSOTCDAC = 0$ <p>In Current Excitation Mode:</p> $FSOTCDAC = \left( \frac{TCi - TCR}{TCS} - 1 \right) \times \frac{393210 \times Ri}{CMRATIO \times RBDR}$ <p>If TCS and/or TCR is not specified, set FSOTCDAC = 0            If the calculated FSOTCDAC is negative, set FSOTCDAC = 0.            If the calculated FSOTCDAC is greater than 65535, set FSOTCDAC = 65535.            TCi = 600 ppm/°C            Ri = 10k<math>\Omega</math>            CMRATIO: See CMRATIO equation            RBDR (<math>\Omega</math>) is the sensor Bridge Resistance specified by user            TCR (ppm/°C) and TCS (ppm/°C) are sensor's temperature coefficient of the sensor Bridge Resistance and Sensitivity, respectively, specified by user</p>



# MAX1454 Evaluation System

## Evaluates: MAX1454

**Table 3. Sensor Definition Equations (continued)**

PARAMETER	EQUATION										
ODAC	$\text{Virodac} = 0.744 \times \text{IRO\_Index} \times \text{VDDX}$ $\text{input\_offset} = \text{sensor\_offset} \times \text{VBDR}$ $\text{ODAC} = \left( 65535 \times \frac{\text{desired\_offset}}{\text{VDDX}} \right) \times \left( 65535 \times \frac{(\text{input\_offset} + \text{Virodac}) \times \text{PGA\_gain}}{\text{VDDX} \times 1000} \right) - \left( \text{OTCDAC} \times \left( \frac{\text{VBDR}}{\text{VDDX}} \right) \right)$ <p>If the calculated ODAC is negative, set ODAC = 0.            If the calculated ODAC is greater than 65535, set ODAC = 65535.            IRO_index: See IRO Index equation            VDDX (V) is External Supply Voltage specified by user            Sensor_Offset (mV/V) is sensor offset specified by user            Desired_Offset (V) is the target calibrated offset specified by user            OTCDAC is value of OTCDAC specified by user            VBDR (V) is the Target Bridge Excitation voltage specified by user            PGA_gain (V/V) is calculated signal path gain</p>										
IRO Index	$\text{input\_offset} = \text{sensor\_offset} \times \text{VBDR}$ $\text{IRO}\% = \frac{\text{input\_offset}}{\text{VDDX} \times 1000} \times 100$ $\text{IRO\_index} = (-1) \times \text{ROUND} \left( \frac{\text{IRO}\%}{0.0744} \right)$ <p>If the calculated IIRO_indexl is greater than 15, set IIRO_indexl to 15.            VDDX (V) is External Supply Voltage specified by user            Sensor_Offset (mV/V) is sensor offset specified by user            VBDR (V) is the Target Bridge Excitation voltage specified by user            ROUND() function rounds the input value to the nearest integer</p>										
PGA Index	$\text{gain} = \text{Desired\_Span} \times \frac{1000}{\text{Sensitivity} \times \text{VBDR}}$ <p>PGA_Index = Select index of first value larger than gain from Table 7 in MAX1454 IC data sheet</p> <p>Desired_Span (V) is the target calibrated output span, specified by user            Sensitivity (mV/V) is the sensor sensitivity, specified by user</p>										
CMRATIO	<p>Select CMRATIO from below, based on the value of RBDR</p> <table style="width: 100%; border-collapse: collapse;"> <thead> <tr> <th style="text-align: left; border-bottom: 1px solid black;">CMRATIO</th> <th style="text-align: left; border-bottom: 1px solid black;">Range</th> </tr> </thead> <tbody> <tr> <td>6</td> <td>RBDR ≥ 8k</td> </tr> <tr> <td>12</td> <td>4k ≤ RBDR &lt; 8k</td> </tr> <tr> <td>18</td> <td>2.7k ≤ RBDR &lt; 4k</td> </tr> <tr> <td>30</td> <td>RBDR &lt; 2.7k</td> </tr> </tbody> </table> <p>RBDR (Ω) is the sensor Bridge Resistance specified by user</p>	CMRATIO	Range	6	RBDR ≥ 8k	12	4k ≤ RBDR < 8k	18	2.7k ≤ RBDR < 4k	30	RBDR < 2.7k
CMRATIO	Range										
6	RBDR ≥ 8k										
12	4k ≤ RBDR < 8k										
18	2.7k ≤ RBDR < 4k										
30	RBDR < 2.7k										

# MAX1454 Evaluation System

## Evaluates: MAX1454

### **Detailed Description of Hardware**

The MAX1454 EV system includes one MAX1454 master board and one MAX1454 EV board. The EV system provides a proven design to evaluate up to 15 MAX1454 precision sensor signal conditioners. The EV system also includes Windows XP-, Windows Vista-, and Windows 7-compatible software that provide a simple graphical user interface (GUI) for exercising the features of the IC. The master board includes interface circuitry to communicate between the IC and the host computer, circuitry to address each of the 15 devices in a fully loaded system, and circuitry to connect to the EV board in position 1. The EV board comes installed with a MAX1454AUE/V+ in a 16-pin TSSOP package. The daughter board includes circuitry and relays to connect to the EV board. Each position in the system, with the exception of position 1, requires a daughter board and an EV board. Figure 1 shows how the EV system and DB system should be connected.

### **Connections**

To connect the EV board to the master board, connect the J3 connector on the master board to the J1 connector on the EV board with the flex cable. Similarly, to connect the EV board to the daughter board, connect the J3 connector on the daughter board to the J1 connector on the EV board with the flex cable.

Carefully connect the master board and the daughter board by aligning the 20-pin right-angle header (J1) on the daughter board with the 20-pin right-angle connector (J2) on the master board. Gently press them together. If more daughter boards need to be cascaded to the EV system, connect the 20-pin connector (J2) on the last daughter board with the 20-pin connector (J1) on the additional daughter board. Use the USB AB cable to connect the EV system to the computer.

### **Power Supply**

By default, the master board and the EV board are USB powered. To use an external power supply for the digital

circuits, connect a 5V supply to the DVDD and DGND terminals, and place the shunt on jumper JU1 on the master board in the 2-3 position. The digital circuitry of the daughter board is powered by the master board. To use an external power supply for a daughter board, connect a 5.5V supply to the DVDD and GND terminals, and place the shunt on jumper JU1 on the daughter board in the 2-3 position.

To use an external power supply for the MAX1454 (on the EV board), apply power to the EXT\_VDD and GND terminals on the master board and place the shunt on jumper JU5 in the 1-3 position. The power-supply voltage should be set between 3V and 5.5V.

### **Power LED**

The master board has a power indicator. When the master board is powered up, LED2 (next to the RESET switch) lights up.

### **Active Device LED**

Only one MAX1454 device can be powered and in communication with the controller at a time. The active device is selected in the EV system software, and the corresponding selected device LED1 on the master board or daughter board lights up.

### **Sensors**

The EV board has an on-board S2 socket and an S1 footprint for the user to install the sensor.

### **Interpreter Definition**

The interpreter is a DLL function that the user can import to his software to communicate with the EV system

### **Function Definition**

```
// cmd = Command string
// msg = Return message string
extern "C" int __stdcall __declspec(dllexport) interpreter
(char *cmd, char *msg);
```

**Table 4. Interpreter Return Values**

FUNCTION RETURN VALUE	DESCRIPTION
0	Board-connection error
1	Command executed successfully
2	Syntax error
3	Communication error

# MAX1454 Evaluation System

## Evaluates: MAX1454

**Table 5. EV System-Related Commands**

COMMAND (char *cmd)	RETURN MESSAGE (char *msg)	DESCRIPTION	EXAMPLE
evsys_connect	"OK"/"Failed"	Connect to the EV system	evsys_connect
evsys_disconnect	"OK"/"Failed"	Disconnect from the EV system	evsys_disconnect
select_board <i>board#</i>	"OK"/"Failed"	Selects the active board <i>board#</i> (in decimal) <i>board#</i> 1 = master board <i>board#</i> 2 = first cascaded daughter board etc.	select_board 15
pwr_connect <i>on/off</i>	"OK"/"Failed"	Turn on/off the power relay on the selected active board	pwr_connect on
dio_connect <i>on/off</i>	"OK"/"Failed"	Turn on/off the DIO relay on the selected active board	dio_connect on
master_pwr <i>on/off</i>	"OK"/"Failed"	Turn on/off the master power relay on the master board	master_pwr on
master_dio <i>on/off</i>	"OK"/"Failed"	Turn on/off the master DIO relay on the master board	master_dio on

**Table 6. Read/Write Commands**

COMMAND (char *cmd)	RETURN MESSAGE (char *msg)	DESCRIPTION	EXAMPLE
flash_read_byte <i>addr</i>	<i>value</i> /"Failed"	Read a byte from flash at address <i>addr</i> (11-bit hex)	flash_read_byte 3ff
flash_write_byte <i>addr value</i>	"OK"/"Failed"	Write 1 byte of data ( <i>value</i> ) to the flash at address <i>addr</i> (11-bit hex)	flash_write_byte 016a ff
flash_read_page <i>page_num</i>	<i>512-byte data</i> /"Failed"	Read a page of data from flash	flash_read_page 1
flash_write_page <i>page_num</i> <i>512_byte_data</i>	"OK"/"Failed"	Write 512 bytes of data to the flash on page <i>page_num</i>	flash_wrt_page 1 0123456789abcdef...
flash_page_erase <i>page_num</i>	"OK"/"Failed"	Erase a page on the flash	flash_page_erase 1
flash_erase	"OK"/"Failed"	Erase the whole flash	flash_erase

# MAX1454 Evaluation System

## Evaluates: MAX1454

**Table 7. Register Read/Write Commands**

COMMAND (char *cmd)	RETURN MESSAGE (char *msg)	DESCRIPTION	EXAMPLE
config1 <i>value</i>	“OK”/“Failed”	Write 16-bit hex ( <i>value</i> ) to the CONFIG1 register	config1 abcd
config1 ?	<i>value</i> “Failed”	Read CONFIG1 register	config1 ?
pga <i>value</i>	“OK”/“Failed”	Write 5-bit hex ( <i>value</i> ) to the PGA[4:0] bit field of the CONFIG1 register	pga 1a
pga ?	<i>value</i> “Failed”	Read PGA[4:0] value from the CONFIG1 register	pga ?
pga_sign <i>value</i>	“OK”/“Failed”	Write 1-bit hex ( <i>value</i> ) to the PGA Sign bit field of the CONFIG1 register	pga_sign 0
pga_sign ?	<i>value</i> “Failed”	Read PGA Sign value from the CONFIG1 register	pga_sign ?
iro_sign <i>value</i>	“OK”/“Failed”	Write 1-bit hex ( <i>value</i> ) to the IRO Sign bit field of the CONFIG1 register	iro_sign 0
iro_sign ?	<i>value</i> “Failed”	Read IRO Sign value from the CONFIG1 register	iro_sign ?
iro <i>value</i>	“OK”/“Failed”	Write 4-bit hex ( <i>value</i> ) to the IRO[3:0] bit field of the CONFIG1 register	iro a
iro ?	<i>value</i> “Failed”	Read IRO[3:0] value from the CONFIG1 register	iro ?
cmratio <i>value</i>	“OK”/“Failed”	Write 2-bit hex ( <i>value</i> ) to the CMRATIO[1:0] bit field of the CONFIG1 register	cmratio a
cmratio ?	<i>value</i> “Failed”	Read CMRATIO[1:0] value from the CONFIG1 register	cmratio ?
odac_sign <i>value</i>	“OK”/“Failed”	Write 1-bit hex ( <i>value</i> ) to the ODAC Sign bit field of the CONFIG1 register	odac_sign 0
odac_sign ?	<i>value</i> “Failed”	Read ODAC Sign value from the CONFIG1 register	odac_sign ?
otcdac_sign <i>value</i>	“OK”/“Failed”	Write 1-bit hex ( <i>value</i> ) to the OTCDAC Sign bit field of the CONFIG1 register	otcdac_sign 0
otcdac_sign ?	<i>value</i> “Failed”	Read OTCDAC Sign value from the CONFIG1 register	otcdac_sign ?
config2 <i>value</i>	“OK”/“Failed”	Write 16-bit hex ( <i>value</i> ) to the CONFIG2 register	config2 abcd
config2 ?	<i>value</i> “Failed”	Read CONFIG2 register	config2 ?
enfdet <i>value</i>	“OK”/“Failed”	Write 1-bit hex ( <i>value</i> ) to the ENFDET bit field of the CONFIG2 register	enfdet 0
enfdet ?	<i>value</i> “Failed”	Read ENFDET value from the CONFIG2 register	enfdet ?
refrate <i>value</i>	“OK”/“Failed”	Write 2-bit hex ( <i>value</i> ) to the REFRATE[1:0] bit field of the CONFIG2 register	refrate 2
refrate ?	<i>value</i> “Failed”	Read REFRATE[1:0] value from the CONFIG2 register	refrate ?
enpullup <i>value</i>	“OK”/“Failed”	Write 1-bit hex ( <i>value</i> ) to the ENPULLUP bit field of the CONFIG2 register	enpullup 0
enpullup ?	<i>value</i> “Failed”	Read ENPULLUP value from the CONFIG2 register	enpullup ?
readdy <i>value</i>	“OK”/“Failed”	Write 2-bit hex ( <i>value</i> ) to the READDLY[1:0] bit field of the CONFIG2 register	readdy 2
readdy ?	<i>value</i> “Failed”	Read READDLY[1:0] value from the CONFIG2 register	readdy ?
excimode <i>value</i>	“OK”/“Failed”	Write 1-bit hex ( <i>value</i> ) to the EXCIMODE bit field of the CONFIG2 register	excimode 0
excimode ?	<i>value</i> “Failed”	Read EXCIMODE value from the CONFIG2 register	excimode ?
odac <i>value</i>	“OK”/“Failed”	Write 16-bit hex ( <i>value</i> ) to the ODAC register	odac 0
odac ?	<i>value</i> “Failed”	Read ODAC register	odac ?
otcdac <i>value</i>	“OK”/“Failed”	Write 16-bit hex ( <i>value</i> ) to the OTCDAC register	otcdac abcd
otcdac ?	<i>value</i> “Failed”	Read OTCDAC register	otcdac ?

# MAX1454 Evaluation System

## Evaluates: MAX1454

**Table 7. Register Read/Write Commands (continued)**

COMMAND (char *cmd)	RETURN MESSAGE (char *msg)	DESCRIPTION	EXAMPLE
fsodac <i>value</i>	“OK”/“Failed”	Write 16-bit hex ( <i>value</i> ) to the FSODAC register	fsodac 0
fsodac ?	<i>value</i> /“Failed”	Read FSODAC register	fsodac ?
fsotcdac <i>value</i>	“OK”/“Failed”	Write 16-bit hex ( <i>value</i> ) to the FSOTCDAC register	fsotcdac abcd
fsotcdac ?	<i>value</i> /“Failed”	Read FSOTCDAC register	fsotcdac ?
pwrupcfg <i>value</i>	“OK”/“Failed”	Write 16-bit hex ( <i>value</i> ) to the PWRUPCFG register	pwrupcfg abcd
pwrupcfg ?	<i>value</i> /“Failed”	Read PWRUPCFG register	pwrupcfg ?
digmodetime <i>value</i>	“OK”/“Failed”	Write 4-bit hex ( <i>value</i> ) to the DIGMODETIME[3:0] bit field of the PWRUPCFG register	digmodetime a
digmodetime ?	<i>value</i> /“Failed”	Read DIGMODETIME[3:0] value from the PWRUPCFG register	digmodetime ?
ctrlrep <i>value</i>	“OK”/“Failed”	Write 3-bit hex ( <i>value</i> ) to the CTRLREP[2:0] bit field of the PWRUPCFG register	ctrlrep 7
ctrlrep ?	<i>value</i> /“Failed”	Read CTRLREP[2:0] value from the PWRUPCFG register	ctrlrep ?

**Table 8. Additional Commands**

COMMAND (char *cmd)	RETURN MESSAGE (char *msg)	DESCRIPTION	EXAMPLE
init_com	“OK”/“Failed”	Power cycle and initialize communication	init_com
init_delay <i>8bit_value</i>	“OK”/“Failed”	Insert delay between closing the power relay and sending the initial byte to the device. Delay = 0.5ms + <i>8bit_value</i> x 0.1ms	init_delay 20
init_delay ?	<i>value</i> /“Failed”	Read initial delay parameter	init_delay ?
read_test_com_reg	“CA”/“Failed”	Read the test communication register. It should return CAhex	read_test_com_reg
rdalg	OUT/DIO Voltage + “V”/“Failed”	Output the multiplexed analog signal onto OUT/DIO. The on-board ADC automatically reads the voltage on the OUT/DIO pin and returns the data to the PC.	rdalg
swtoana	“OK”/“Failed”	Switch to fixed analog mode	swtoana
read_adc	OUT/DIO Voltage + “V”/“Failed”	On-board ADC conversion	read_adc
relearn_baud	“OK”/“Failed”	relearn the baud rate	relearn_baud
temp_sensor ?	<i>value</i> /“Failed”	Read temperature sensor register	temp_sensor ?
aloc <i>value</i>	“OK”/“Failed”	Write 5-bit hex ( <i>value</i> ) to the ALOC register	aloc 15
aloc ?	<i>value</i> /“Failed”	Read ALOC register	aloc ?
atim <i>value</i>	“OK”/“Failed”	Write 4-bit hex ( <i>value</i> ) to the ATIM register	atim f
atim ?	<i>value</i> /“Failed”	Read ATIM register	atim ?
scan	a string of 1/0/“Failed”	Send test communication command to all 15 devices. Return a character string of 1/0 that indicates which devices are functioning. e.g., “101111111111111” this means the 2nd device doesn't respond to the test communication command	scan
dll_version ?	“DLL version =” #.##/“Failed”	Return the DLL version	dll_version ?
maxq_version ?	“MAXQ version =” #.##/“Failed”	Return the MAXQ FW version	maxq_version ?



# MAX1454 Evaluation System

## Evaluates: MAX1454

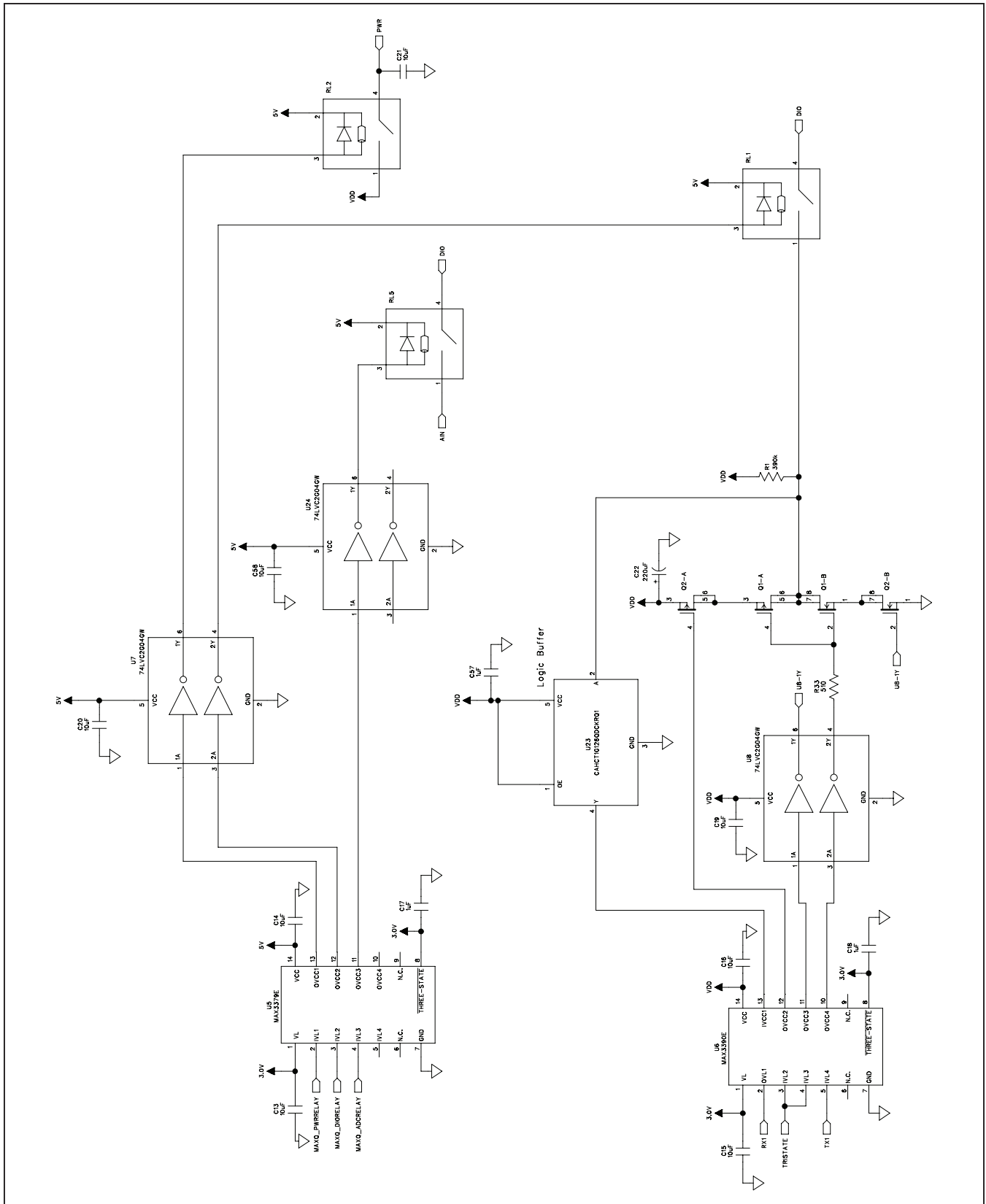

Figure 8a. MAX1454 Master Board Schematic (Sheet 1 of 6)

# MAX1454 Evaluation System

## Evaluates: MAX1454

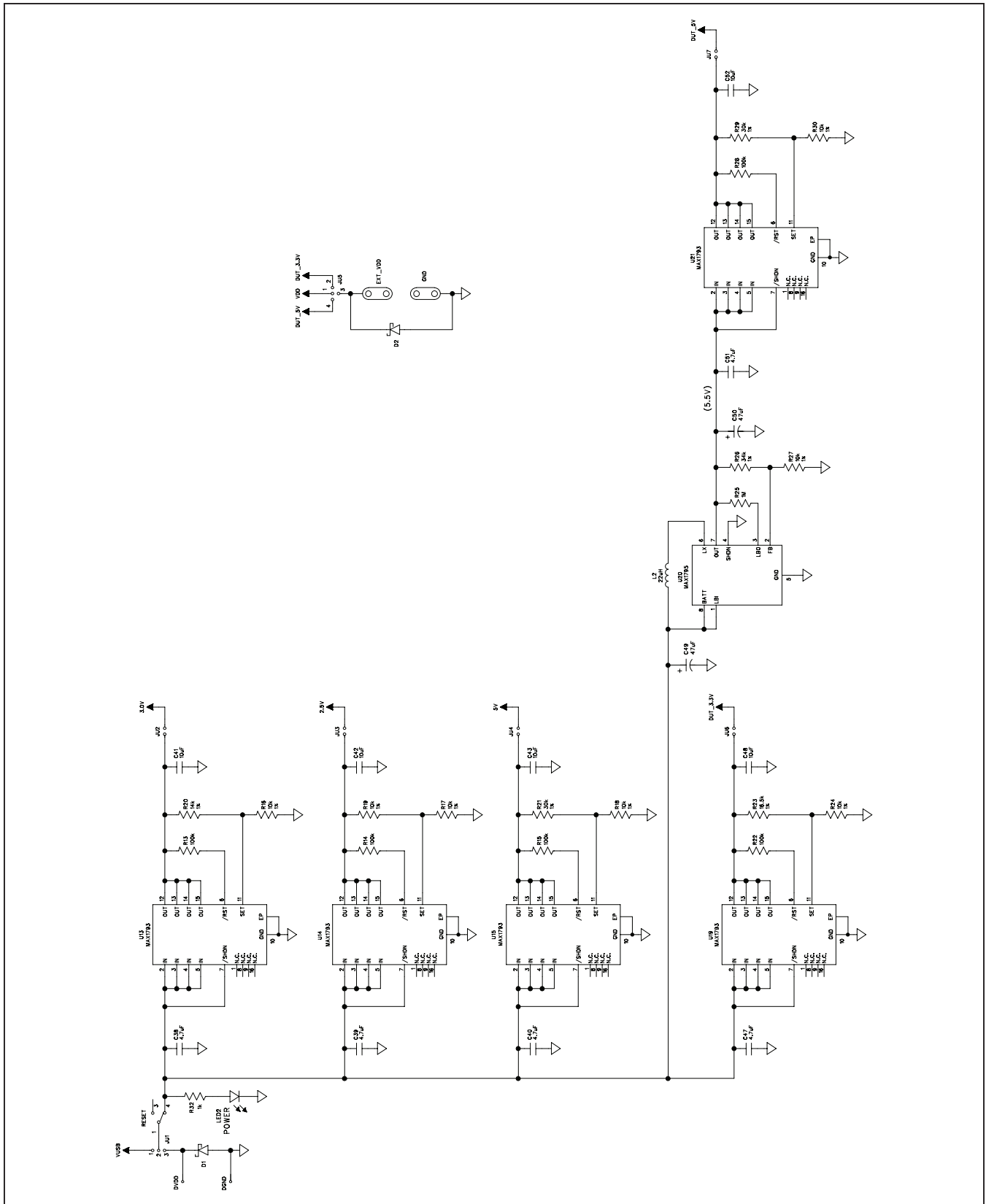

Figure 8b. MAX1454 Master Board Schematic (Sheet 2 of 6)

# MAX1454 Evaluation System

## Evaluates: MAX1454

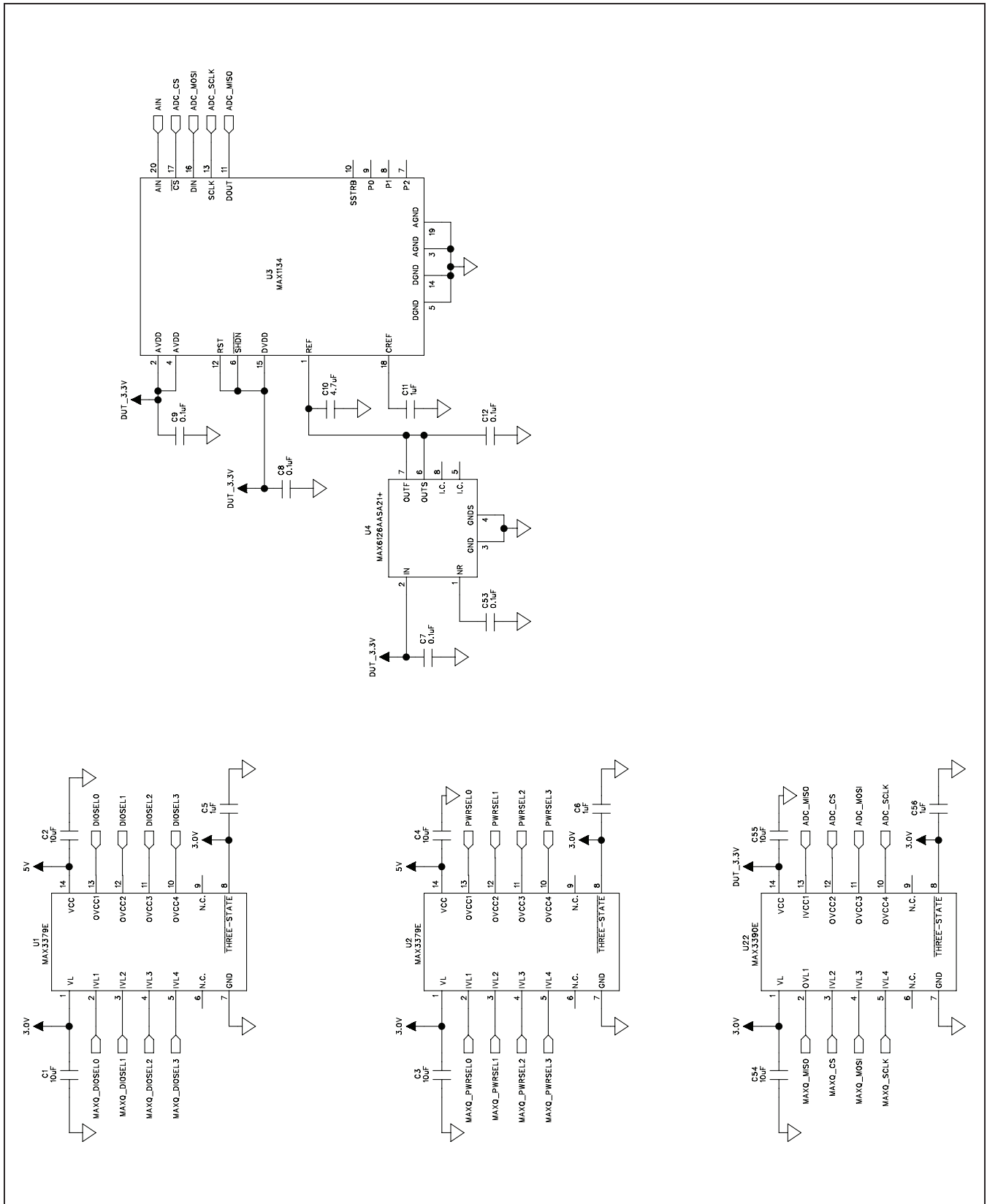

Figure 8c. MAX1454 Master Board Schematic (Sheet 3 of 6)

# MAX1454 Evaluation System

## Evaluates: MAX1454

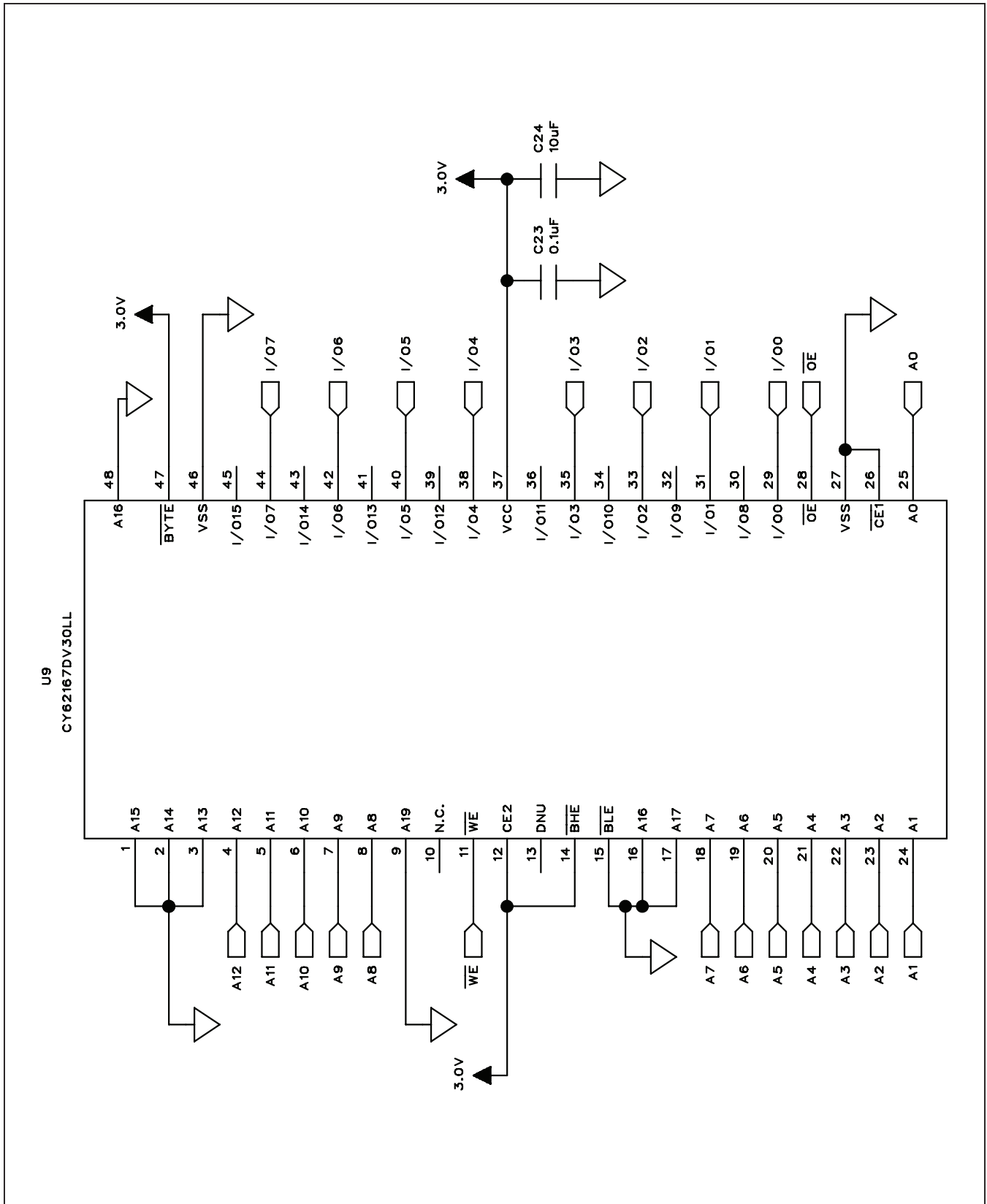

Figure 8d. MAX1454 Master Board Schematic (Sheet 4 of 6)

# MAX1454 Evaluation System

## Evaluates: MAX1454

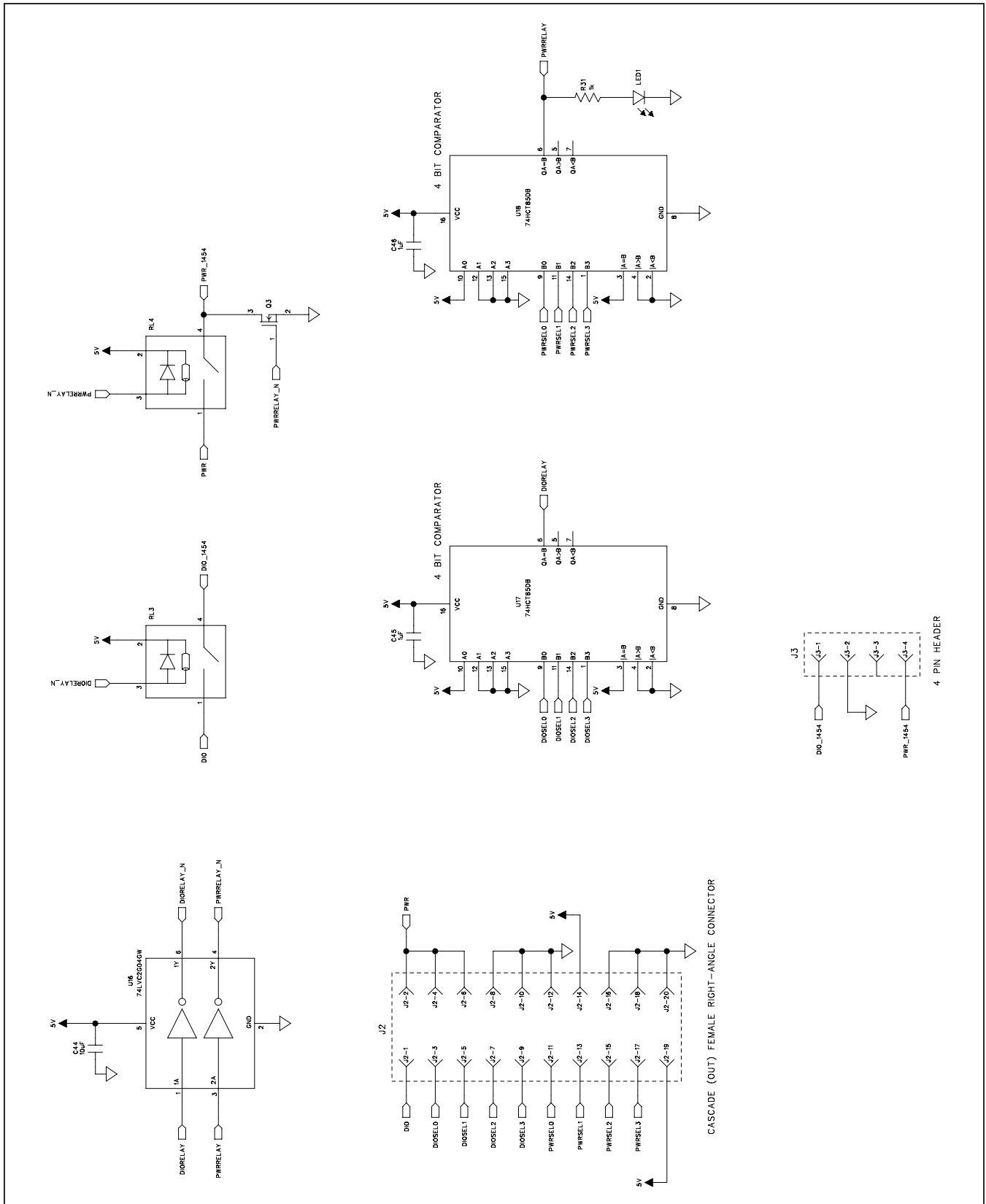

Figure 8e. MAX1454 Master Board Schematic (Sheet 5 of 6)



# MAX1454 Evaluation System

## Evaluates: MAX1454

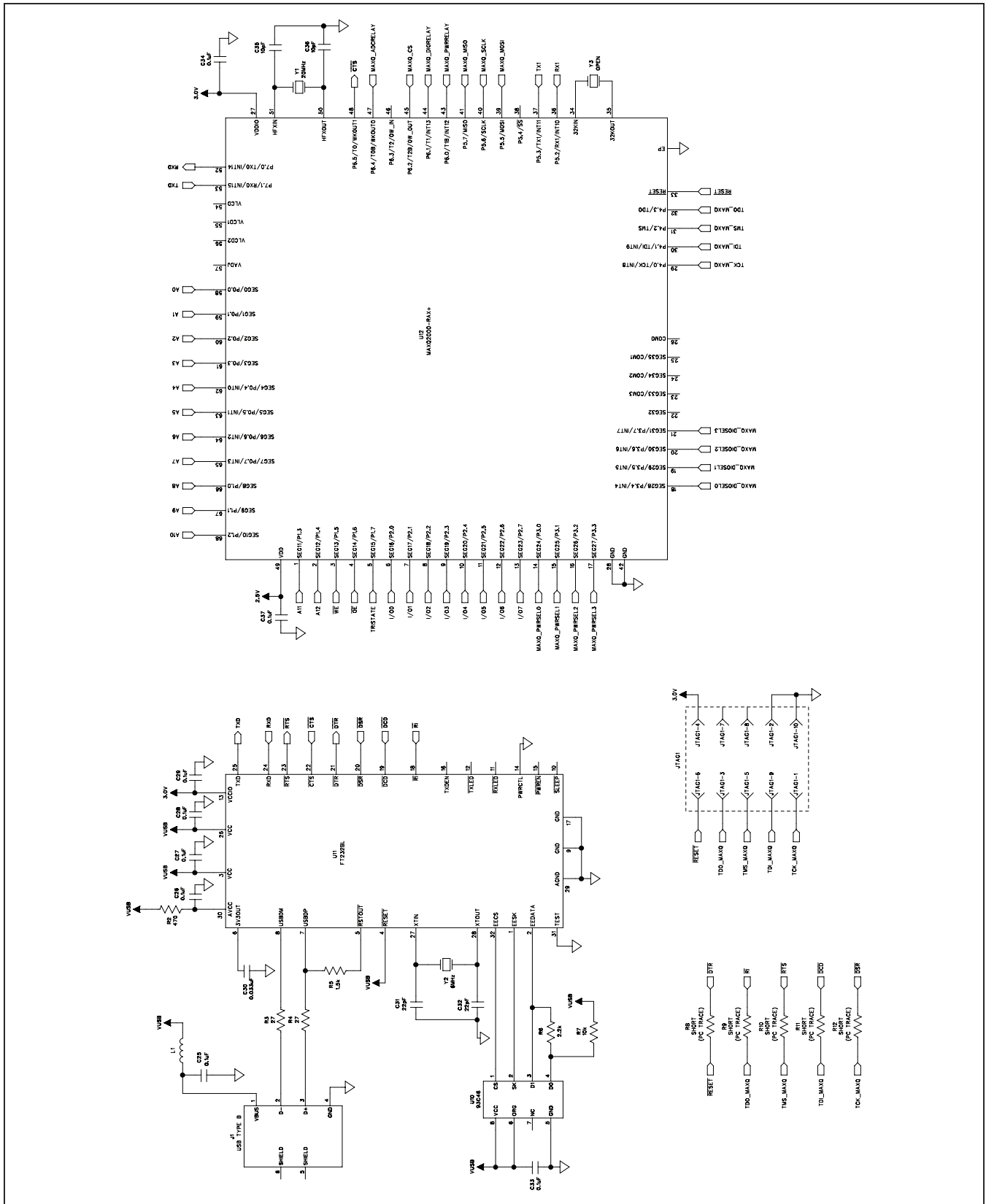

Figure 8f. MAX1454 Master Board Schematic (Sheet 6 of 6)

# MAX1454 Evaluation System

## Evaluates: MAX1454

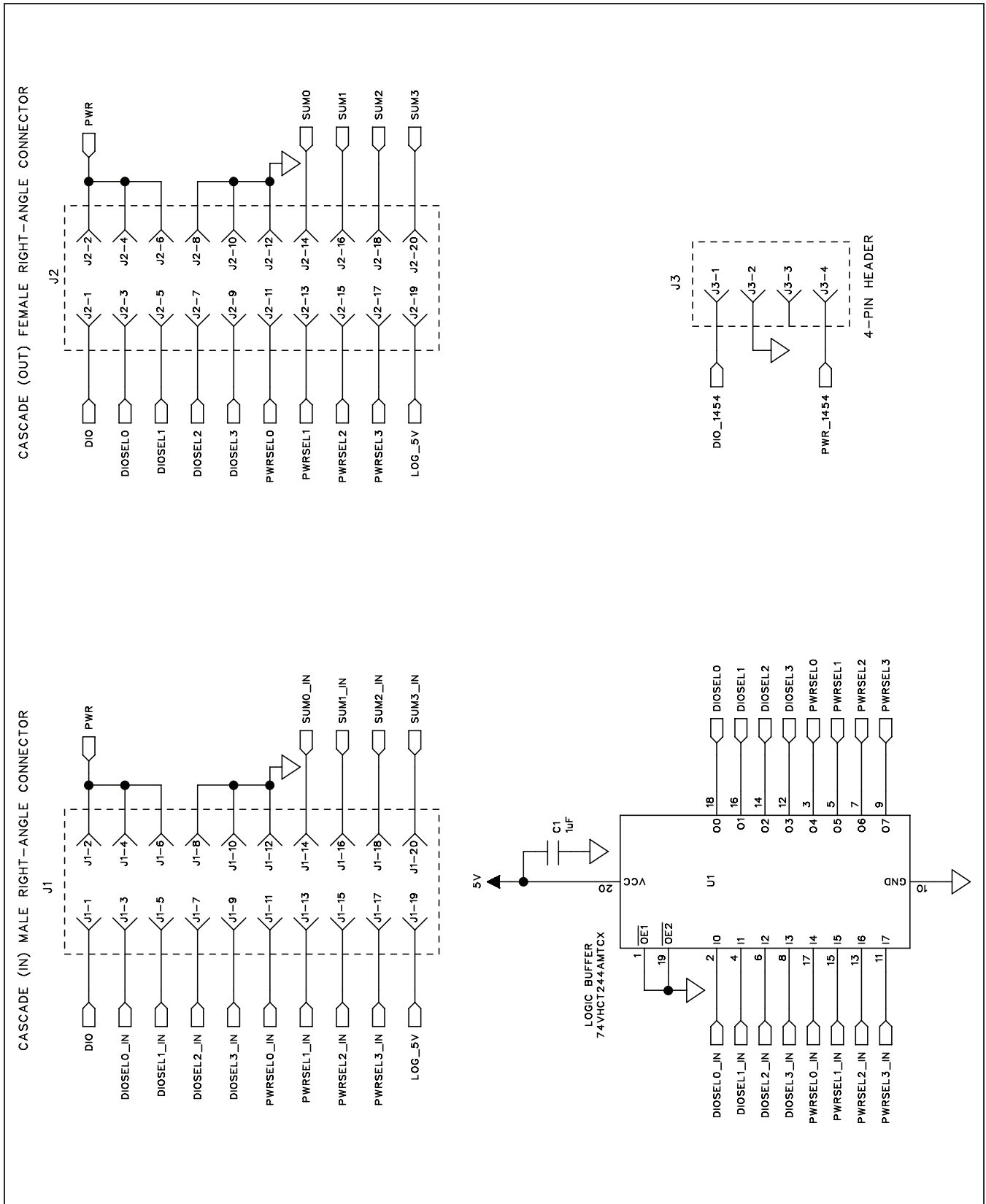

Figure 9a. MAX1454 Daughter Board Schematic (Sheet 1 of 2)



# MAX1454 Evaluation System

## Evaluates: MAX1454

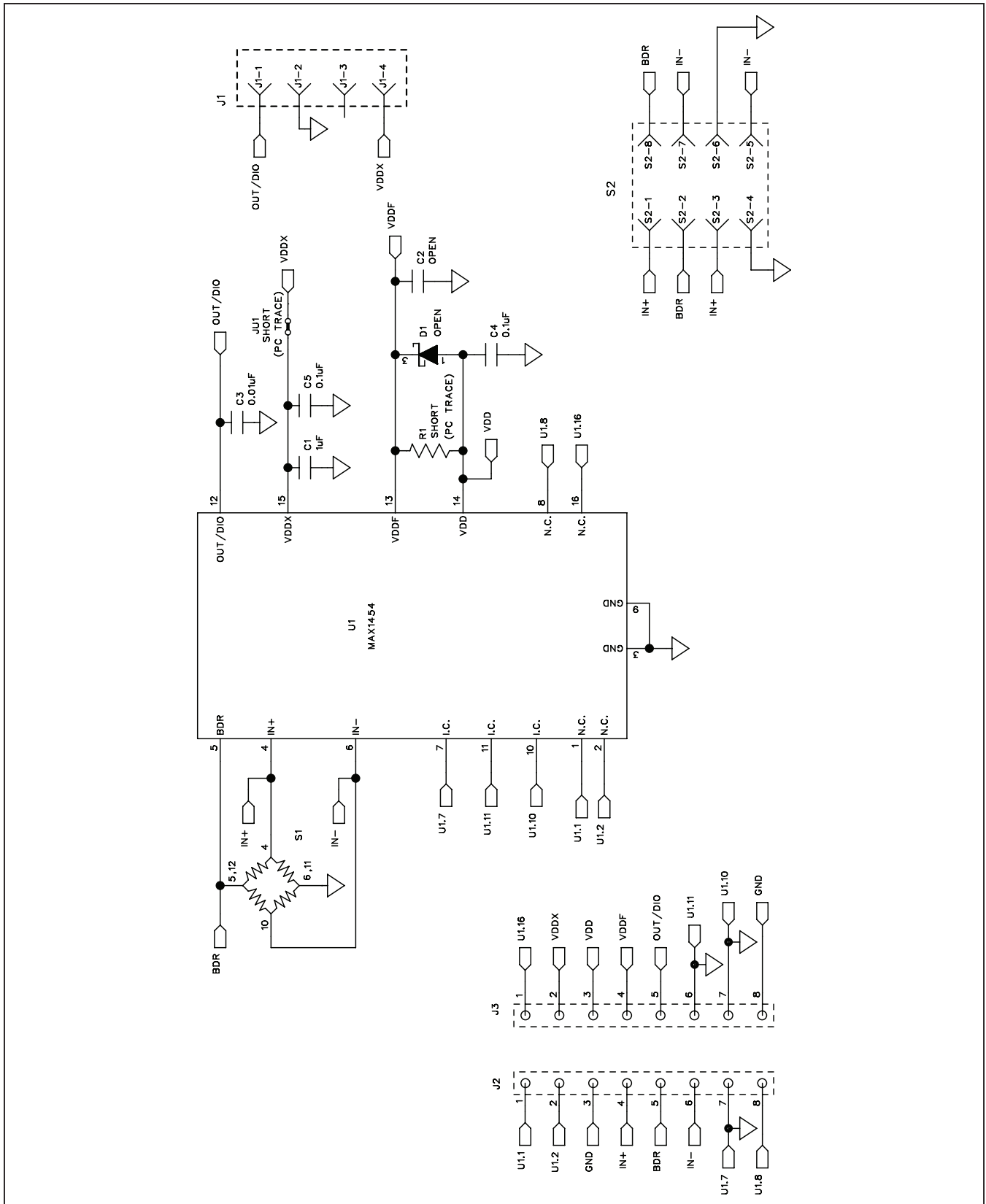

Figure 10. MAX1454 EV Kit Schematic

# MAX1454 Evaluation System

## Evaluates: MAX1454

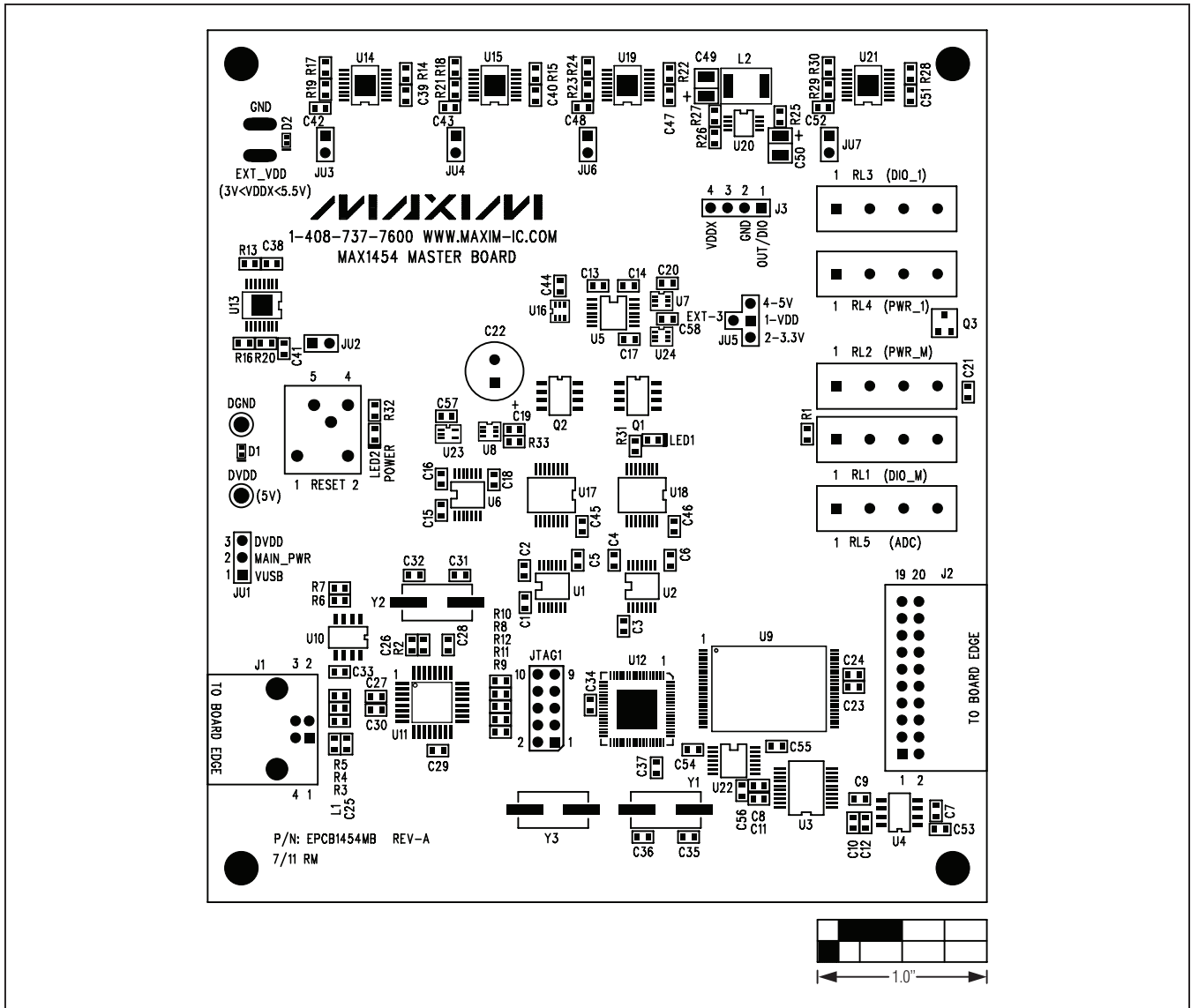

Figure 11. MAX1454 Master Board Component Placement Guide—Component Side

# MAX1454 Evaluation System

## Evaluates: MAX1454

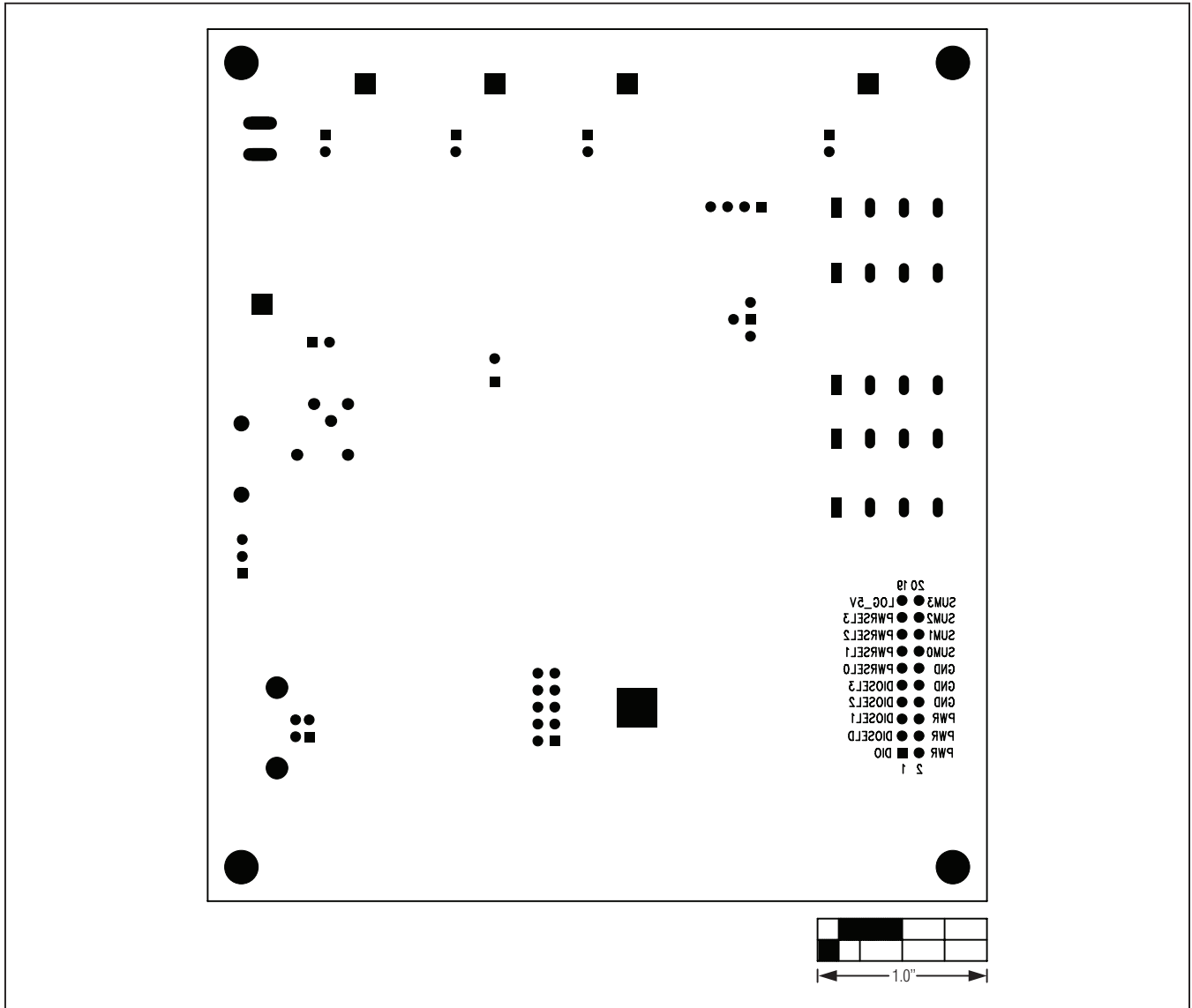

Figure 12. MAX1454 Master Board Component Placement Guide—Bottom Side

# MAX1454 Evaluation System

## Evaluates: MAX1454

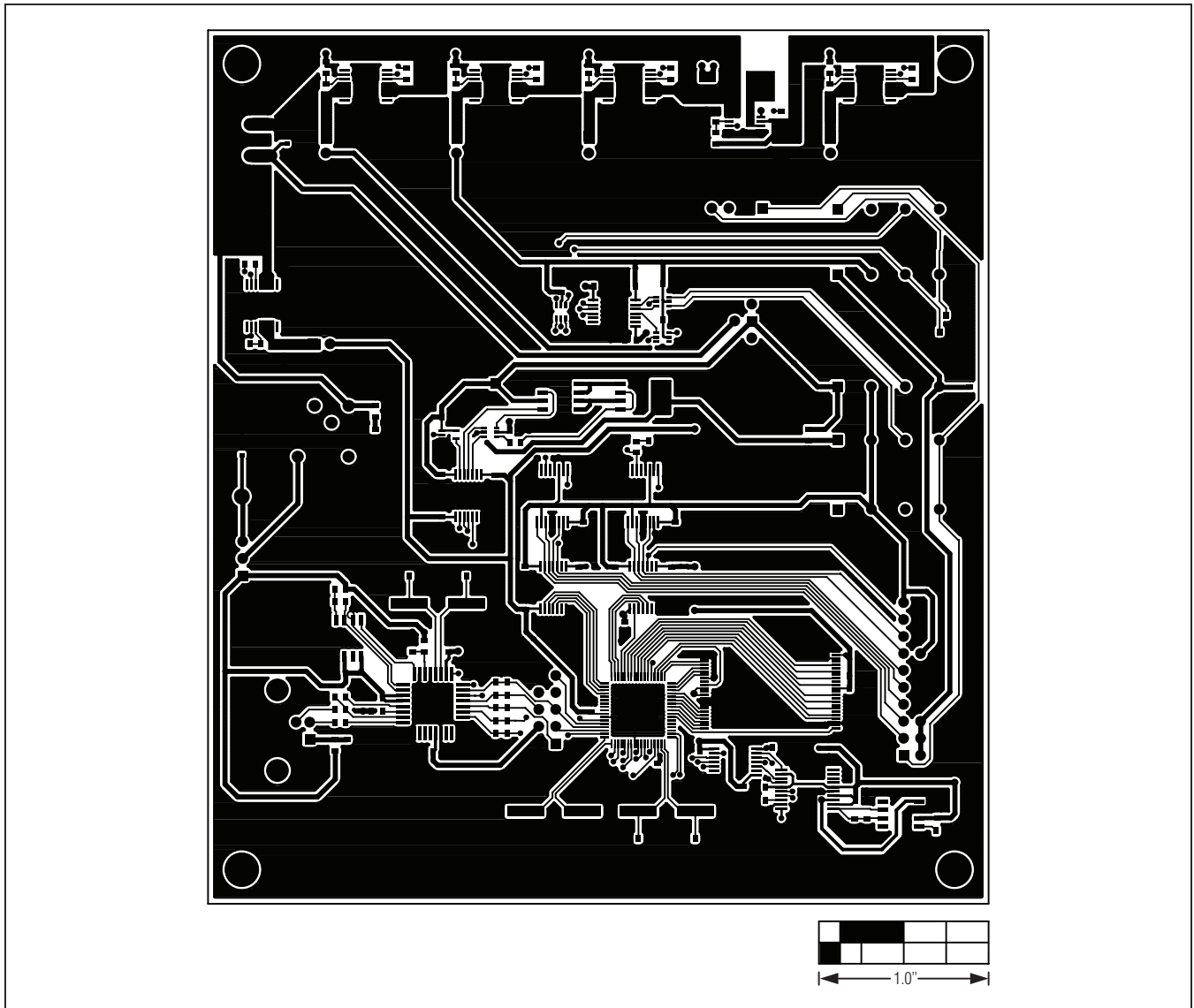

Figure 13. MAX1454 Master Board PCB Layout—Component Side

# MAX1454 Evaluation System

## Evaluates: MAX1454

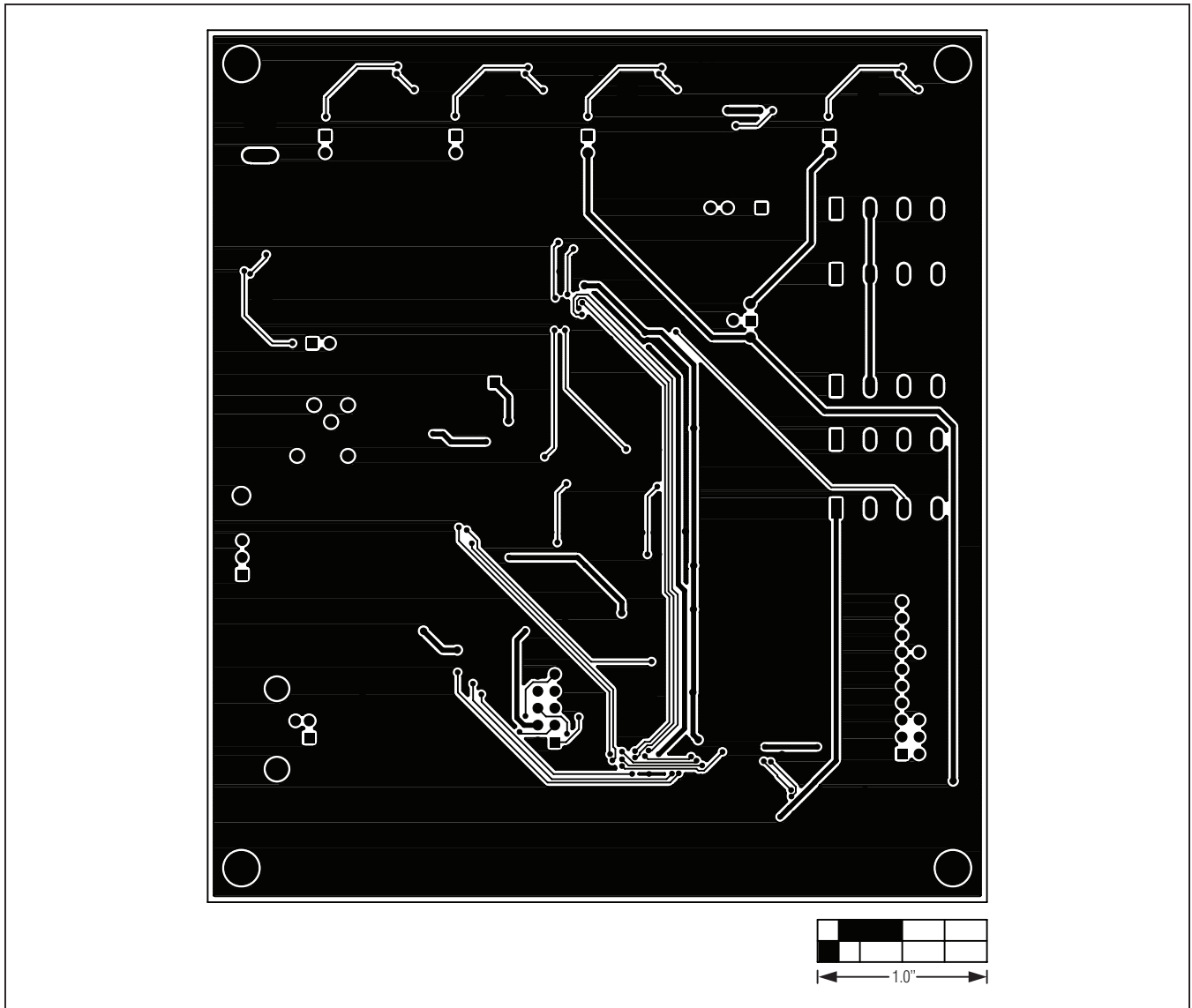

Figure 14. MAX1454 Master Board PCB Layout—Bottom Side



# MAX1454 Evaluation System

## Evaluates: MAX1454

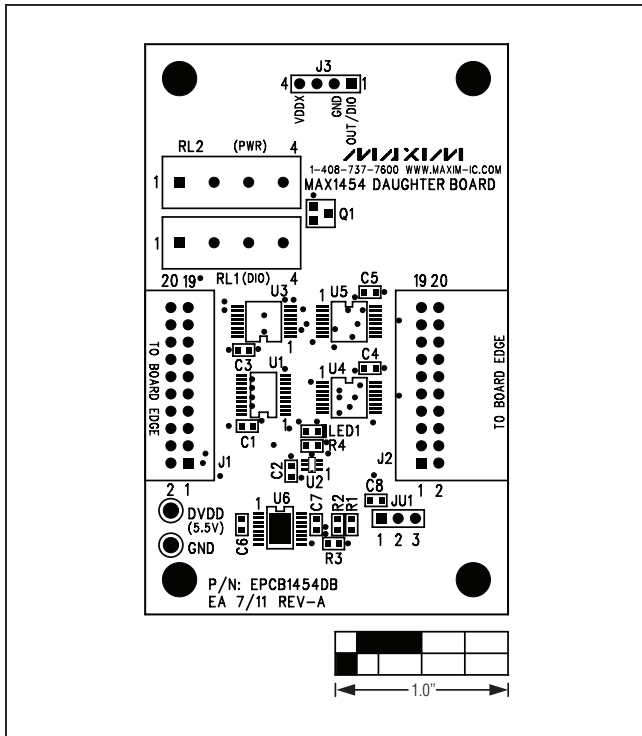

Figure 15. MAX1454 Daughter Board Component Placement Guide—Component Side

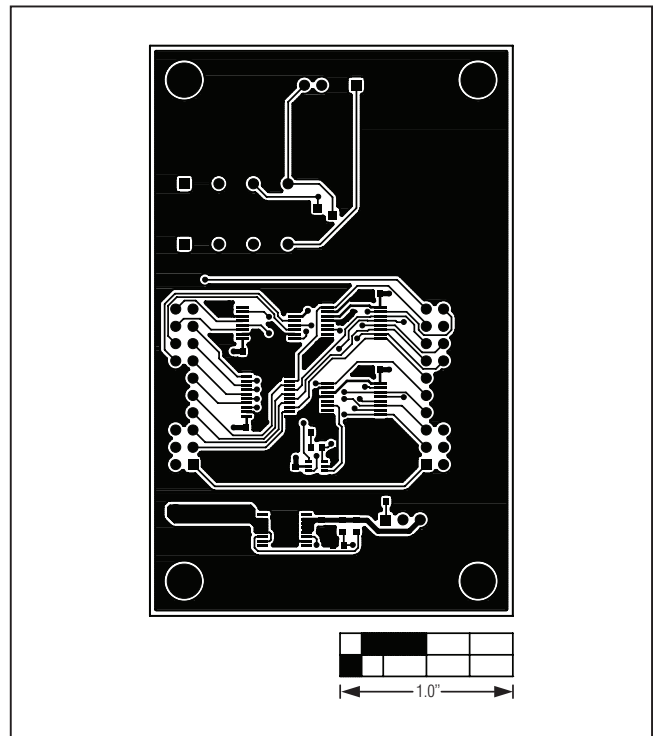

Figure 16. MAX1454 Daughter Board PCB Layout—Component Side

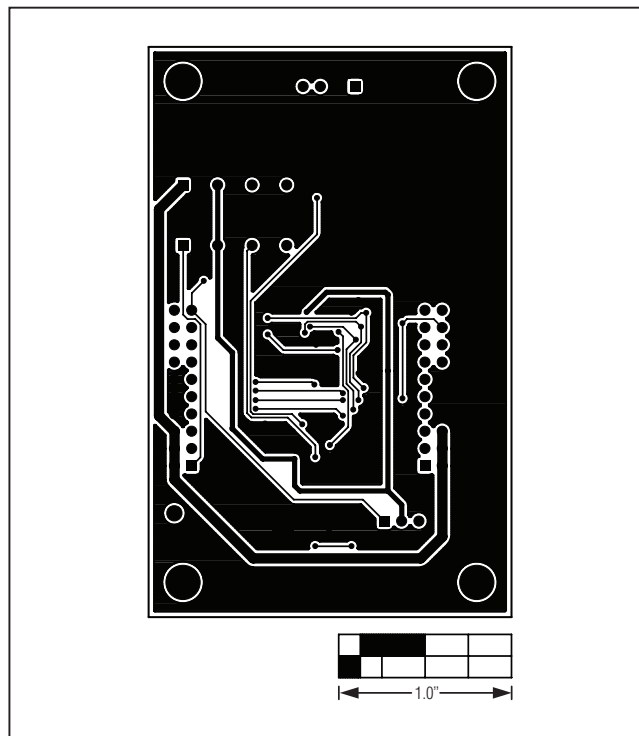

Figure 17. MAX1454 Daughter Board PCB Layout—Bottom Side



# MAX1454 Evaluation System

## Evaluates: MAX1454

### ***Ordering Information***

<b>PART</b>	<b>TYPE</b>	<b>INCLUDES</b>
<b>MAX1454EVSYS#</b>	EV System	MAX1454 Master Board, MAX1454 EV Board
<b>MAX1454DBSYS#</b>	DB System	MAX1454 Daughter Board, MAX1454 EV Board

#Denotes RoHS compliant.

# MAX1454 Evaluation System

## Evaluates: MAX1454

### *Revision History*

REVISION NUMBER	REVISION DATE	DESCRIPTION	PAGES CHANGED
0	10/11	Initial release	—

*Maxim cannot assume responsibility for use of any circuitry other than circuitry entirely embodied in a Maxim product. No circuit patent licenses are implied. Maxim reserves the right to change the circuitry and specifications without notice at any time.*

**Maxim Integrated Products, 120 San Gabriel Drive, Sunnyvale, CA 94086 408-737-7600 \_\_\_\_\_ 35**



Компания «ЭлектроПласт» предлагает заключение долгосрочных отношений при поставках импортных электронных компонентов на взаимовыгодных условиях!

Наши преимущества:

- Оперативные поставки широкого спектра электронных компонентов отечественного и импортного производства напрямую от производителей и с крупнейших мировых складов;
- Поставка более 17-ти миллионов наименований электронных компонентов;
- Поставка сложных, дефицитных, либо снятых с производства позиций;
- Оперативные сроки поставки под заказ (от 5 рабочих дней);
- Экспресс доставка в любую точку России;
- Техническая поддержка проекта, помощь в подборе аналогов, поставка прототипов;
- Система менеджмента качества сертифицирована по Международному стандарту ISO 9001;
- Лицензия ФСБ на осуществление работ с использованием сведений, составляющих государственную тайну;
- Поставка специализированных компонентов (Xilinx, Altera, Analog Devices, Intersil, Interpoint, Microsemi, Aeroflex, Peregrine, Syfer, Eurofarad, Texas Instrument, Miteq, Cobham, E2V, MA-COM, Hittite, Mini-Circuits, General Dynamics и др.);

Помимо этого, одним из направлений компании «ЭлектроПласт» является направление «Источники питания». Мы предлагаем Вам помощь Конструкторского отдела:

- Подбор оптимального решения, техническое обоснование при выборе компонента;
- Подбор аналогов;
- Консультации по применению компонента;
- Поставка образцов и прототипов;
- Техническая поддержка проекта;
- Защита от снятия компонента с производства.



#### Как с нами связаться

**Телефон:** 8 (812) 309 58 32 (многоканальный)

**Факс:** 8 (812) 320-02-42

**Электронная почта:** [org@eplast1.ru](mailto:org@eplast1.ru)

**Адрес:** 198099, г. Санкт-Петербург, ул. Калинина, дом 2, корпус 4, литера А.