

THIS DRAWING IS UNPUBLISHED. RELEASED FOR PUBLICATION 20
 © COPYRIGHT 20 BY - ALL RIGHTS RESERVED.

REVISIONS					
P	LTR	DESCRIPTION	DATE	DWN	APVD
	A	REVISED PER ECR-18-014960	21SEP2018	SS	JL
	A1	REVISED PER ECR-19-008871	13JUN2019	SR	DD
	A2	REVISED PER ECR-19-009651	12JUL2019	SR	DD

1 MATERIALS:
 HOUSING: PBT
 DIMMING CONTACTS (QTY. 4): COPPER ALLOY
 LINE VOLTAGE CONTACTS (QTY. 3): COPPER ALLOY
 GASKET: VINYL/NITRILE FOAM
 O-RING: SILICONE RUBBER
 MEMBRANE VENT: PTFE

2 FINISH:
 DIMMING CONTACTS: NICKEL UNDERPLATE ENTIRE
 CONTACT 0.127 µm MIN THICK. SELECTIVE GOLD PLATE CONTACT
 MATING AREA (MATING FACE SIDE ONLY) 0.76 µm MIN THICK.
 MATTE TIN PLATE TAB ON BOTH SIDES 0.30 µm MIN THICK.
 LINE VOLTAGE CONTACTS: MATTE TIN PLATE

3 MATING INTERFACE PER ANSI C136.41-2013.

4 ADHESIVE BACKED GASKET SUPPLIED BUT NOT INSTALLED.

5 ADDITIONAL COVERS AND SLEEVES OF VARIOUS HEIGHTS ARE AVAILABLE. CONTACT TE CONNECTIVITY FOR MORE OPTIONS.

7. THIS PRODUCT HAS NOT COMPLETED VALIDATION TESTING.

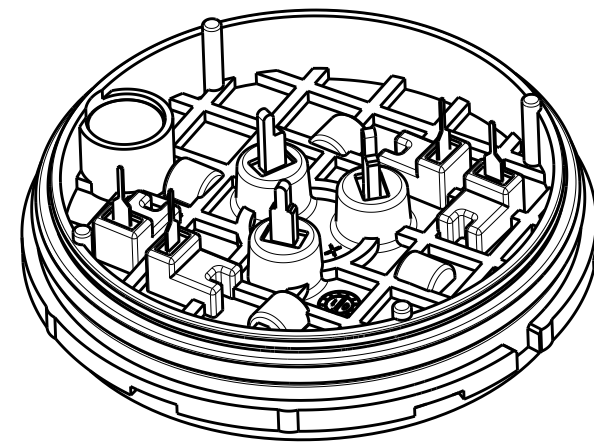

2336396-1 SHOWN

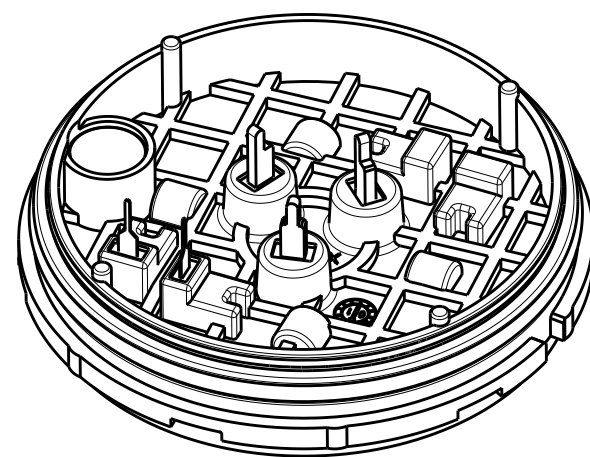

1-2336396-1 SHOWN

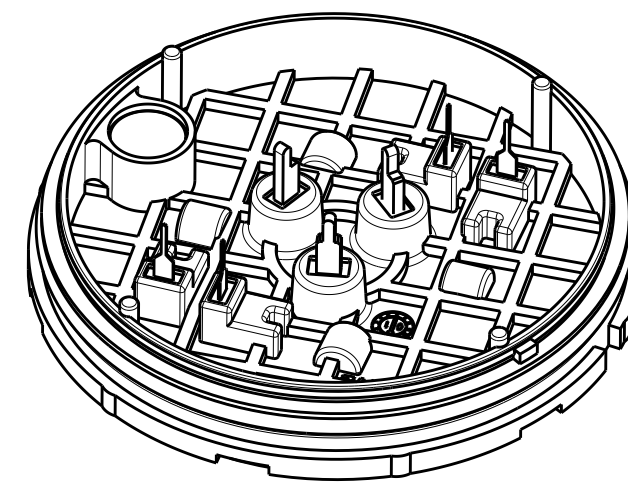

2336396-2 SHOWN

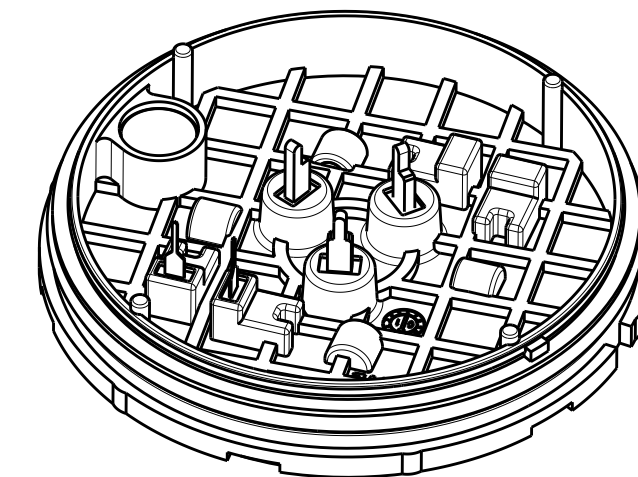

1-2336396-2 SHOWN

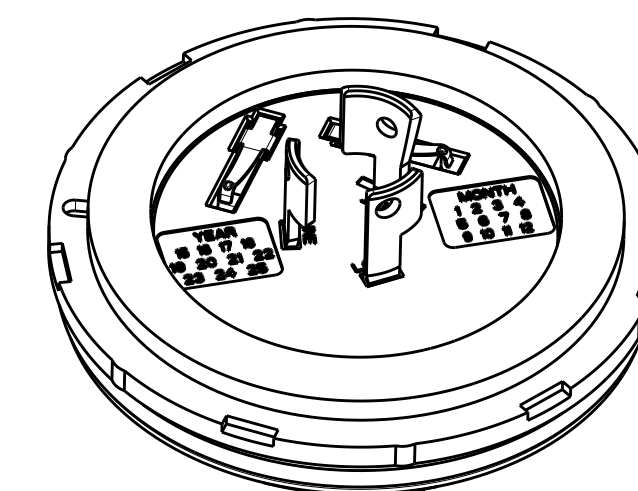
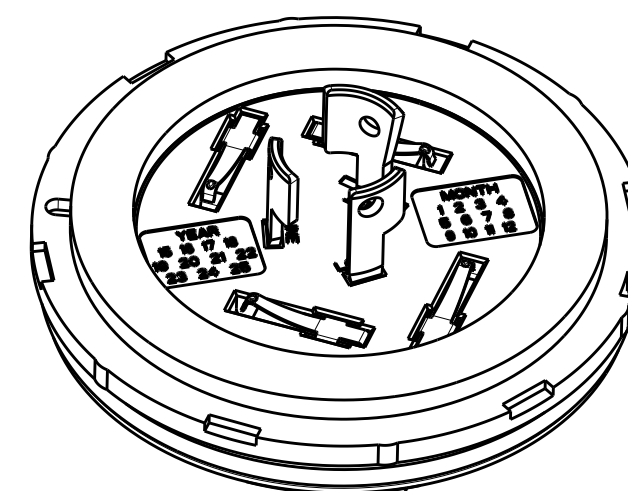
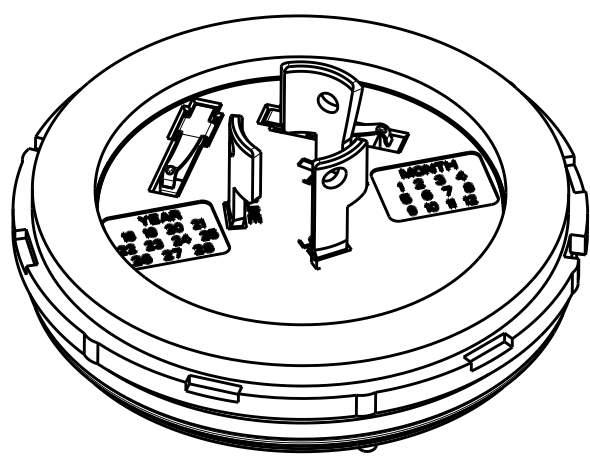
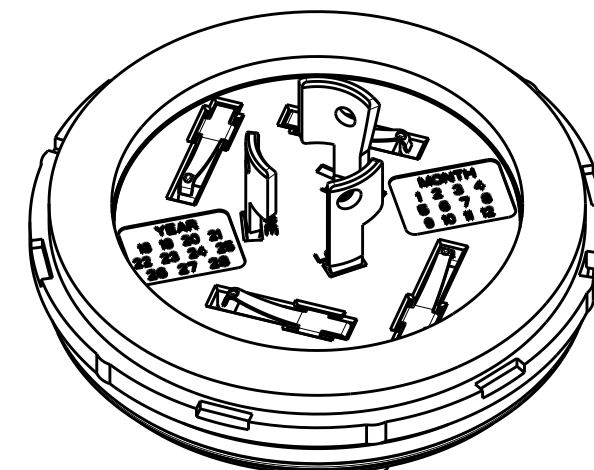

2213996-X	2306130-X	5	13.04	26.20	Ø82.24	Ø78.54	Ø69.80	Ø70.70	Ø72.25	Ø77.53	Ø77.74	Ø81.15	1-2336396-2
2213996-X	2306130-X	7	13.04	26.20	Ø82.24	Ø78.54	Ø69.80	Ø70.70	Ø72.25	Ø77.53	Ø77.74	Ø81.15	2336396-2
2213805-X	2213748-X	5	4.35	27.45	Ø77.00	Ø76.96	Ø64.50	Ø65.00	Ø66.75	Ø71.23	Ø72.00	Ø76.00	1-2336396-1
2213805-X	2213748-X	7	4.35	27.45	Ø77.00	Ø76.96	Ø64.50	Ø65.00	Ø66.75	Ø71.23	Ø72.00	Ø76.00	2336396-1
REPRESENTATIVE SLEEVE P/N 5	REPRESENTATIVE COVER P/N 5	CONTACT POSITIONS	DIM T	DIM S	DIM Y	DIM X	DIM P	DIM N	DIM M MAX WITH SLEEVE	DIM M MAX W/OUT SLEEVE	DIM F	DIM E	PART NO.

THIS DRAWING IS A CONTROLLED DOCUMENT.

DWN: J. SHAFFER 03MAY2018
 CHK: M. MOSTOLLER 03MAY2018
 APVD: -

STE TE Connectivity

NAME: BASE ASSEMBLY, LIGHT CONTROLLER, SLEEVE COMPATIBLE

PRODUCT SPEC: 108-32125
 APPLICATION SPEC: 114-32159

SIZE: A2
 CAGE CODE: -
 DRAWING NO: C-2336396

RESTRICTED TO: -

CUSTOMER DRAWING SCALE: 2:1 SHEET: 1 OF 5 REV: A2

THIS DRAWING IS UNPUBLISHED. RELEASED FOR PUBLICATION 20
 © COPYRIGHT 20 BY - ALL RIGHTS RESERVED.

REVISIONS				
P	LTR	DESCRIPTION	DATE	APVD
-	-	SEE SHEET 1	-	-

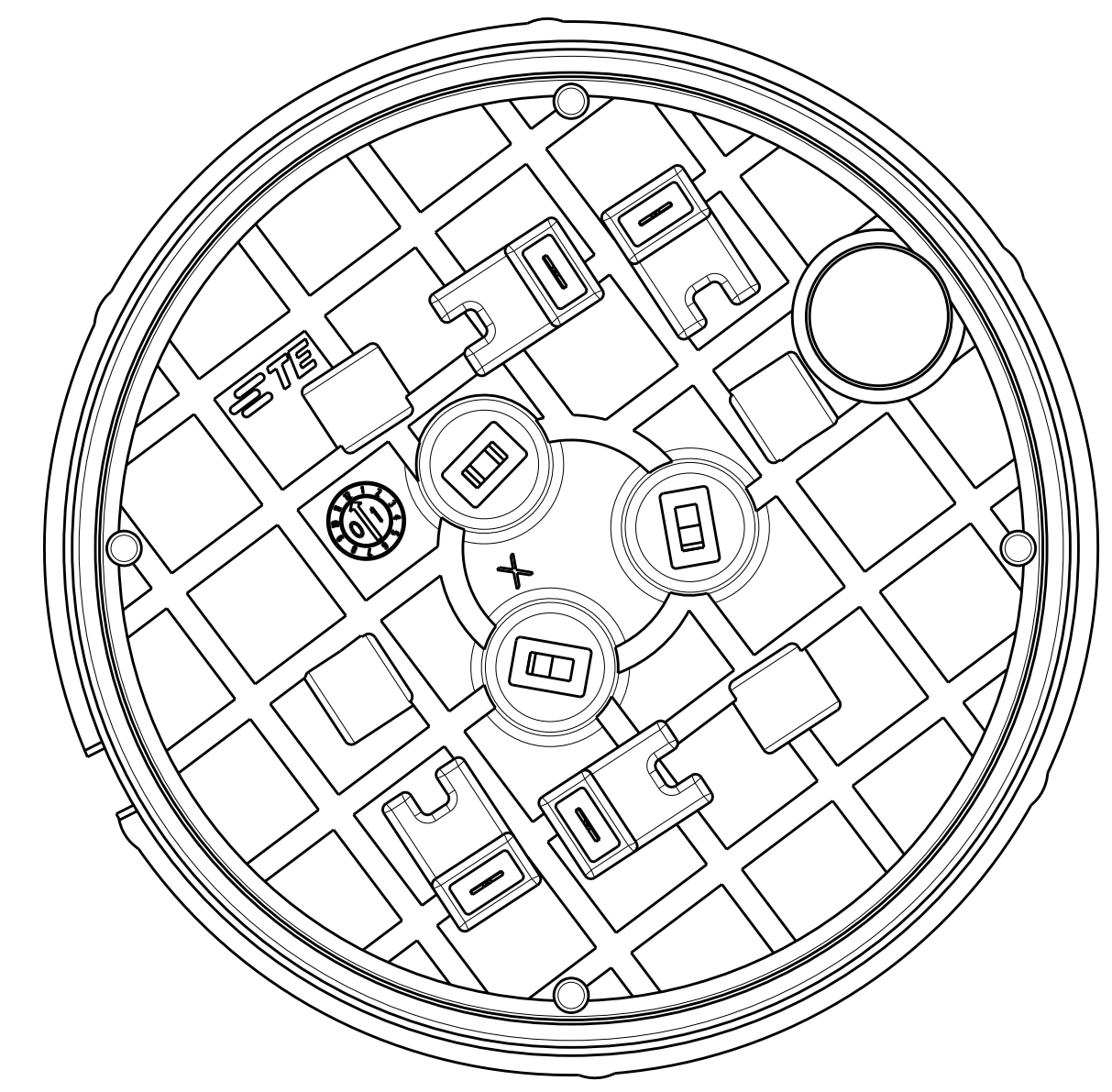
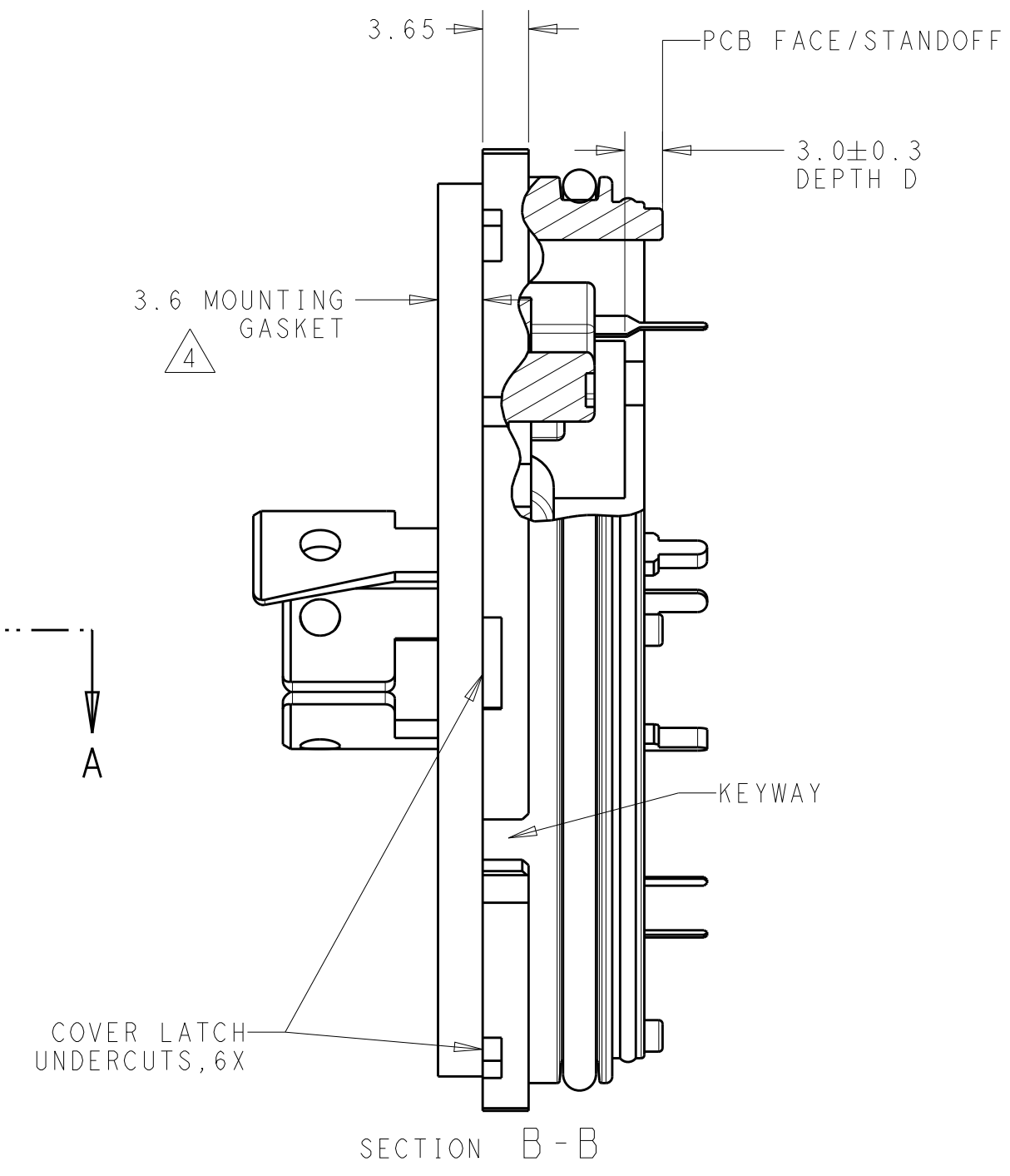
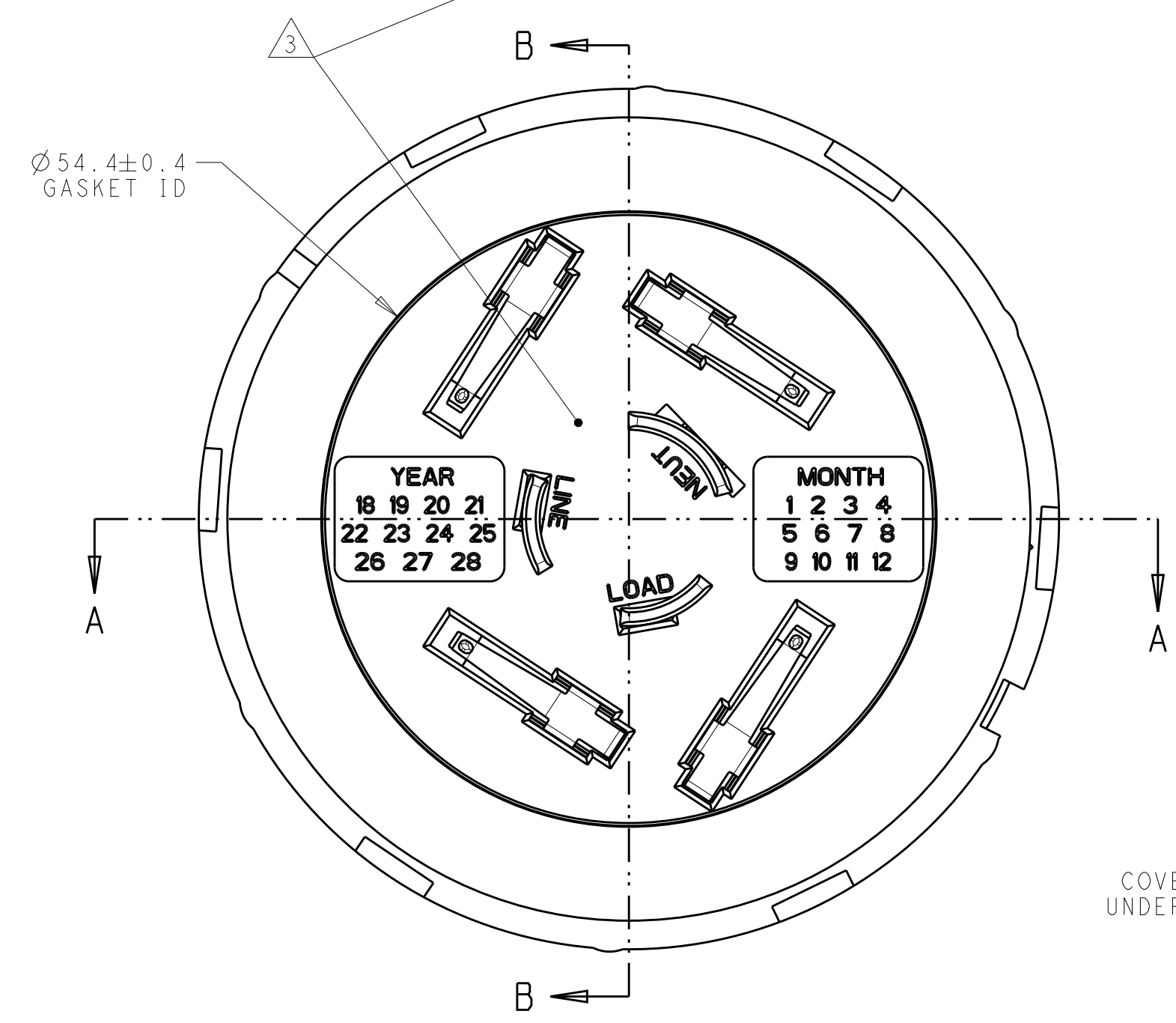
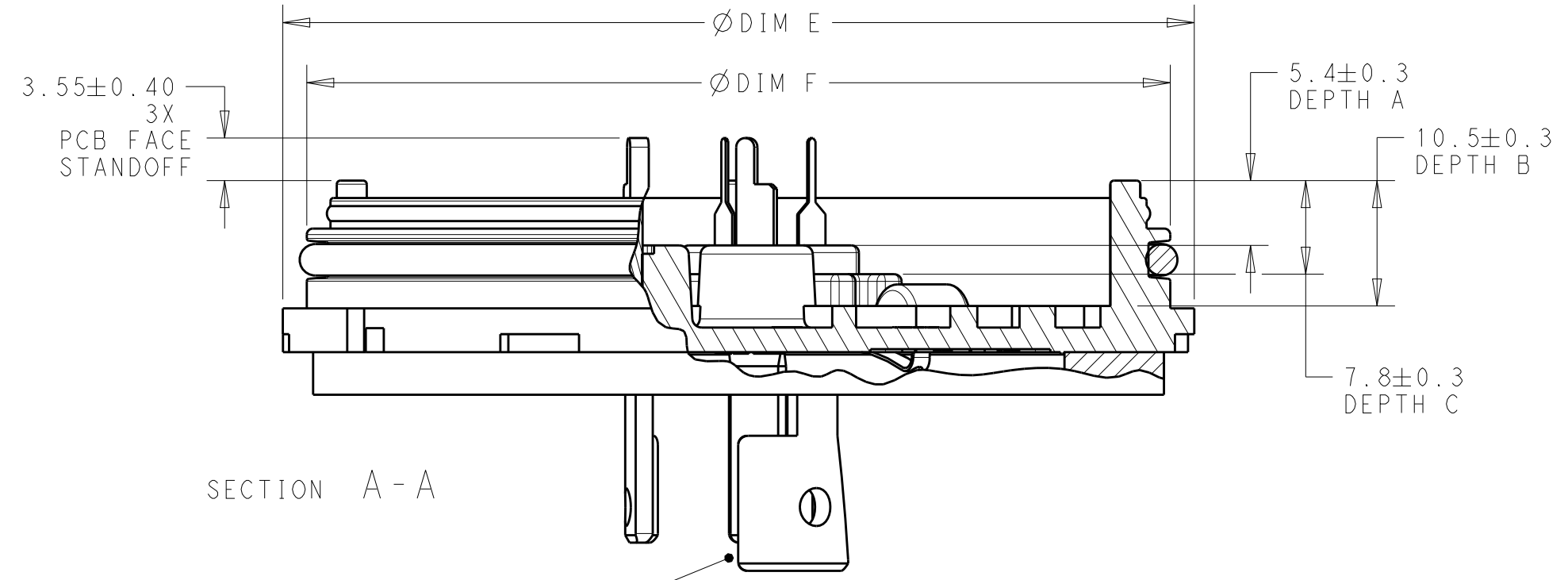

THIS DRAWING IS A CONTROLLED DOCUMENT.		DWN J. SHAFFER 03MAY2018	TE Connectivity	
		CHK M. MOSTOLLER 03MAY2018		
DIMENSIONS: mm		TOLERANCES UNLESS OTHERWISE SPECIFIED: 0 PLC ± 1 PLC ±0.2 2 PLC ±0.13 3 PLC ± 4 PLC ± ANGLES ±3° FINISH		NAME BASE ASSEMBLY, LIGHT CONTROLLER, SLEEVE COMPATIBLE
MATERIAL - -		PRODUCT SPEC 108-32125 APPLICATION SPEC 114-32159 WEIGHT -	SIZE A2 CAGE CODE - DRAWING NO. C-2336396	RESTRICTED TO -
		CUSTOMER DRAWING		SCALE 2:1 SHEET 2 OF 5 REV A2

THIS DRAWING IS UNPUBLISHED. RELEASED FOR PUBLICATION 20
 © COPYRIGHT 20 BY - ALL RIGHTS RESERVED.

REVISIONS				
P	LTR	DESCRIPTION	DATE	APVD
-	-	SEE SHEET 1	-	-

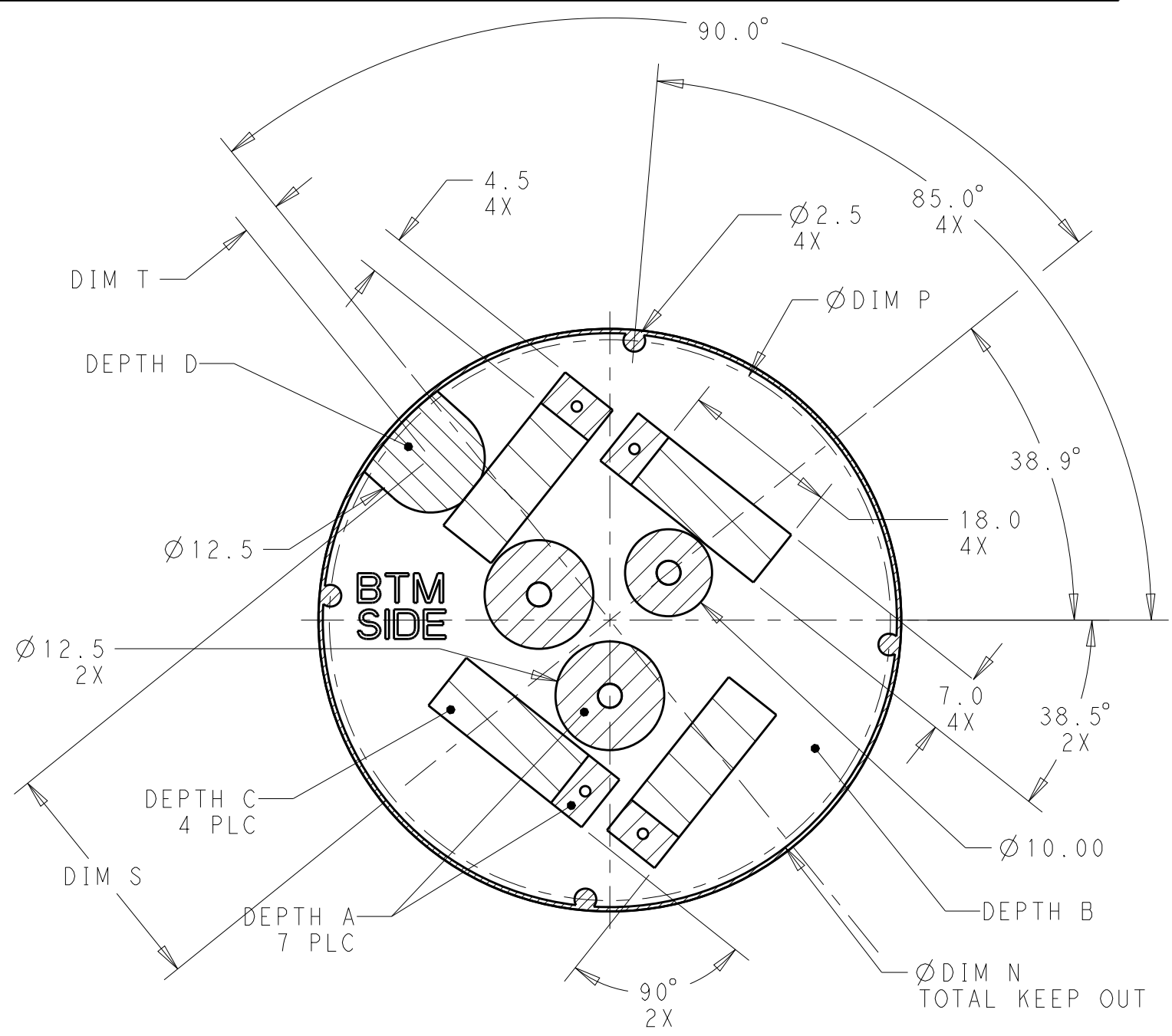

COMPONENT KEEP OUT AREAS
 2336396-1 AND 2336396-2

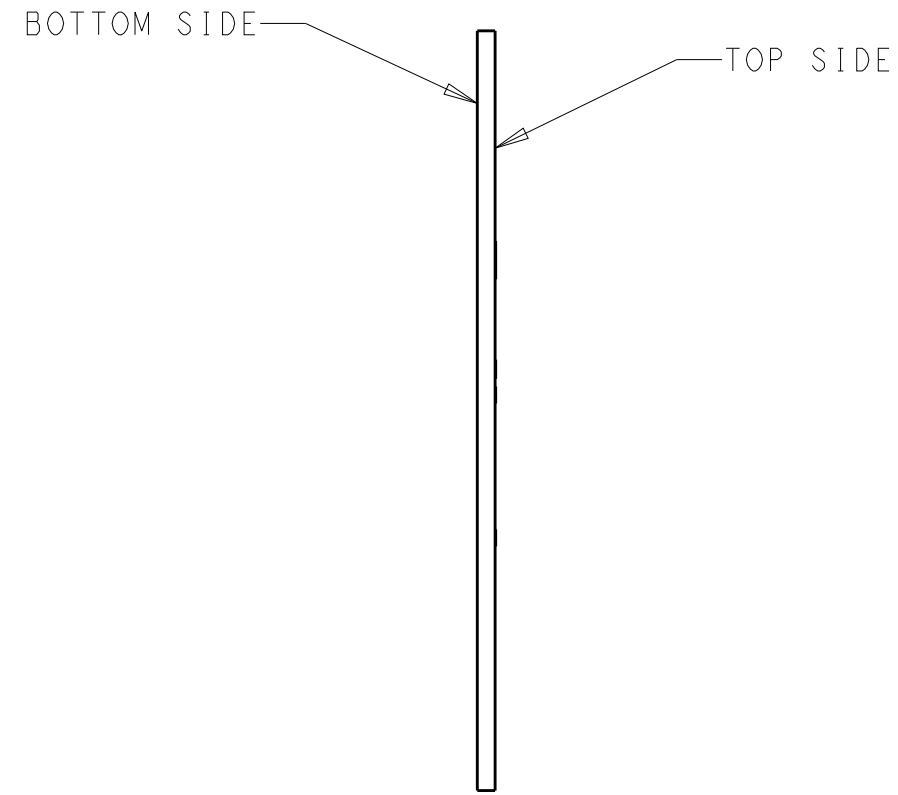

RECOMMENDED PCB
 SCALE 3:2

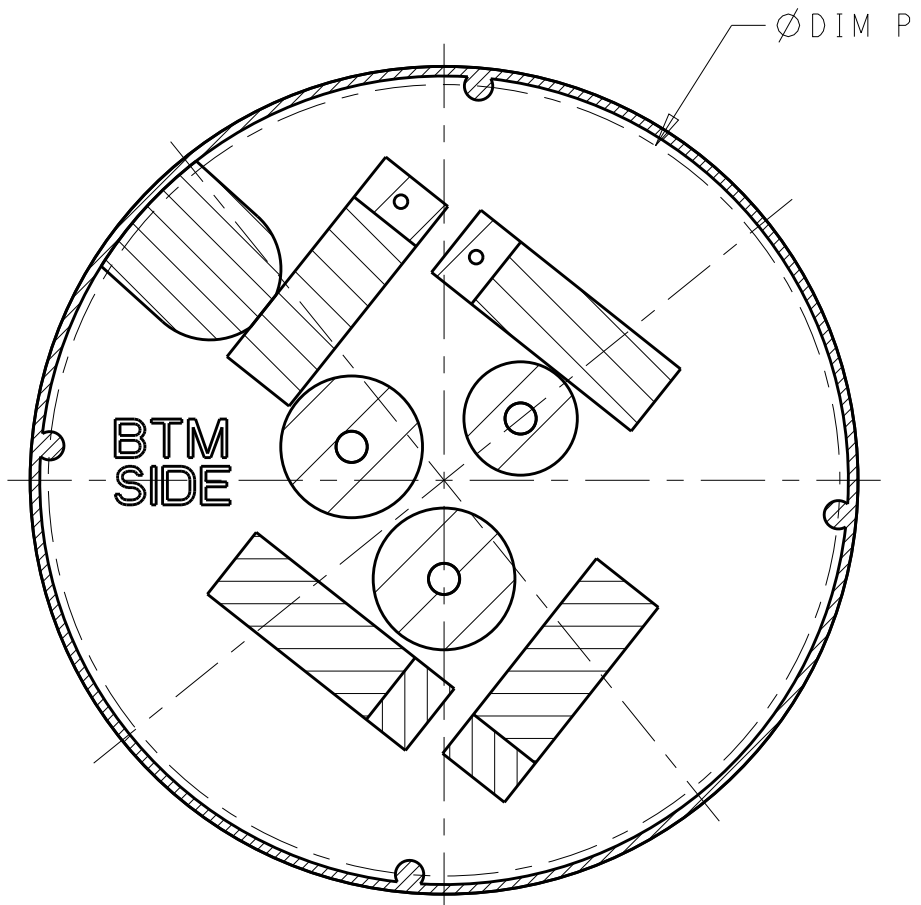
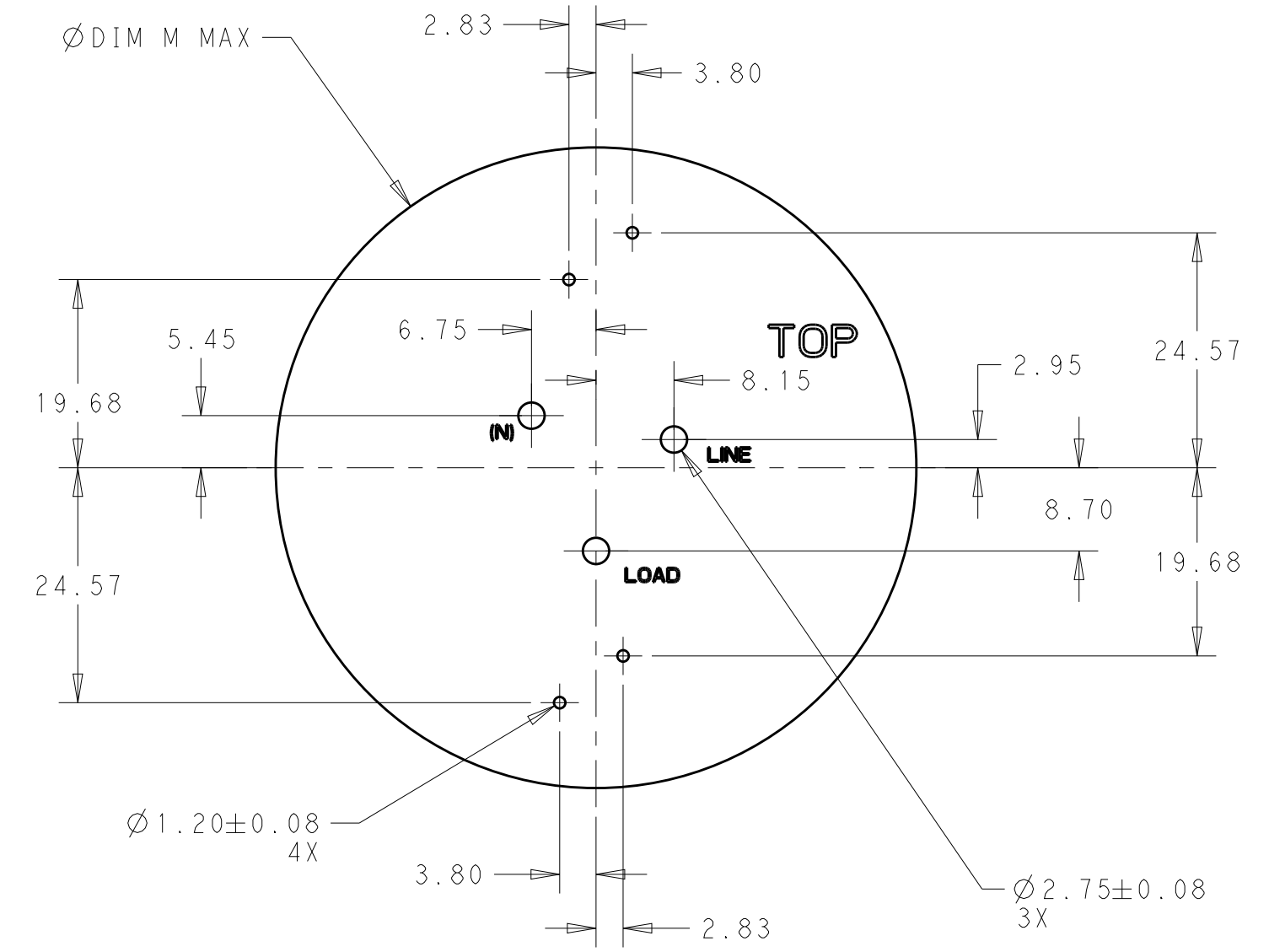

COMPONENT KEEP OUT AREAS
 1-2336396-1 AND 1-2336396-2
 SAME AS
 2336396-1 AND 2336396-2
 EXCEPT WHERE SHOWN

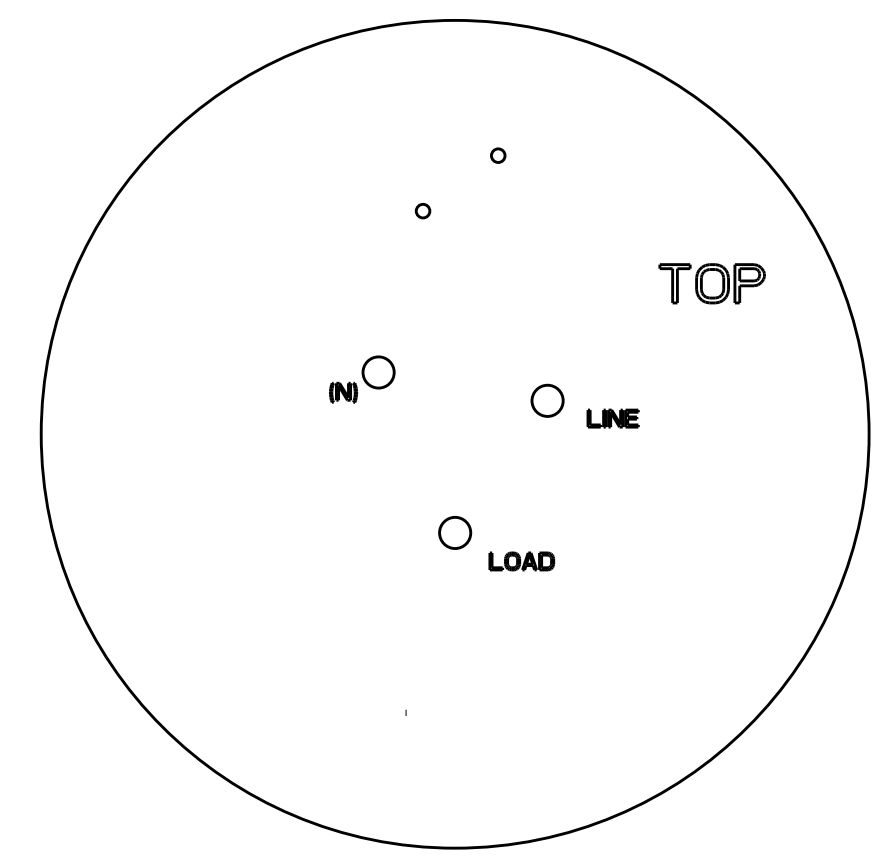
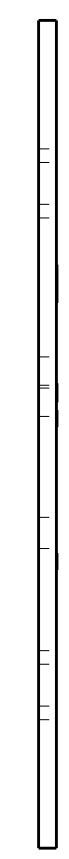

THIS DRAWING IS A CONTROLLED DOCUMENT.		DWN J. SHAFFER 03MAY2018	 TE Connectivity	
		CHK M. MOSTOLLER 03MAY2018		
DIMENSIONS:		APVD -	NAME BASE ASSEMBLY, LIGHT CONTROLLER, SLEEVE COMPATIBLE	
mm	TOLERANCES UNLESS OTHERWISE SPECIFIED:	PRODUCT SPEC 108-32125	SIZE A2	
	0 PLC ±	APPLICATION SPEC 114-32159	CAGE CODE -	DRAWING NO. C-2336396
	1 PLC ±0.2	WEIGHT -	RESTRICTED TO -	
	2 PLC ±0.13	CUSTOMER DRAWING	SCALE 2:1	SHEET 3 OF 5
	3 PLC ±		REV A2	
	4 PLC ±			
	ANGLES ±3°			
	FINISH			

REVISIONS				
P	LTR	DESCRIPTION	DATE	APVD
-	-	SEE SHEET 1	-	-

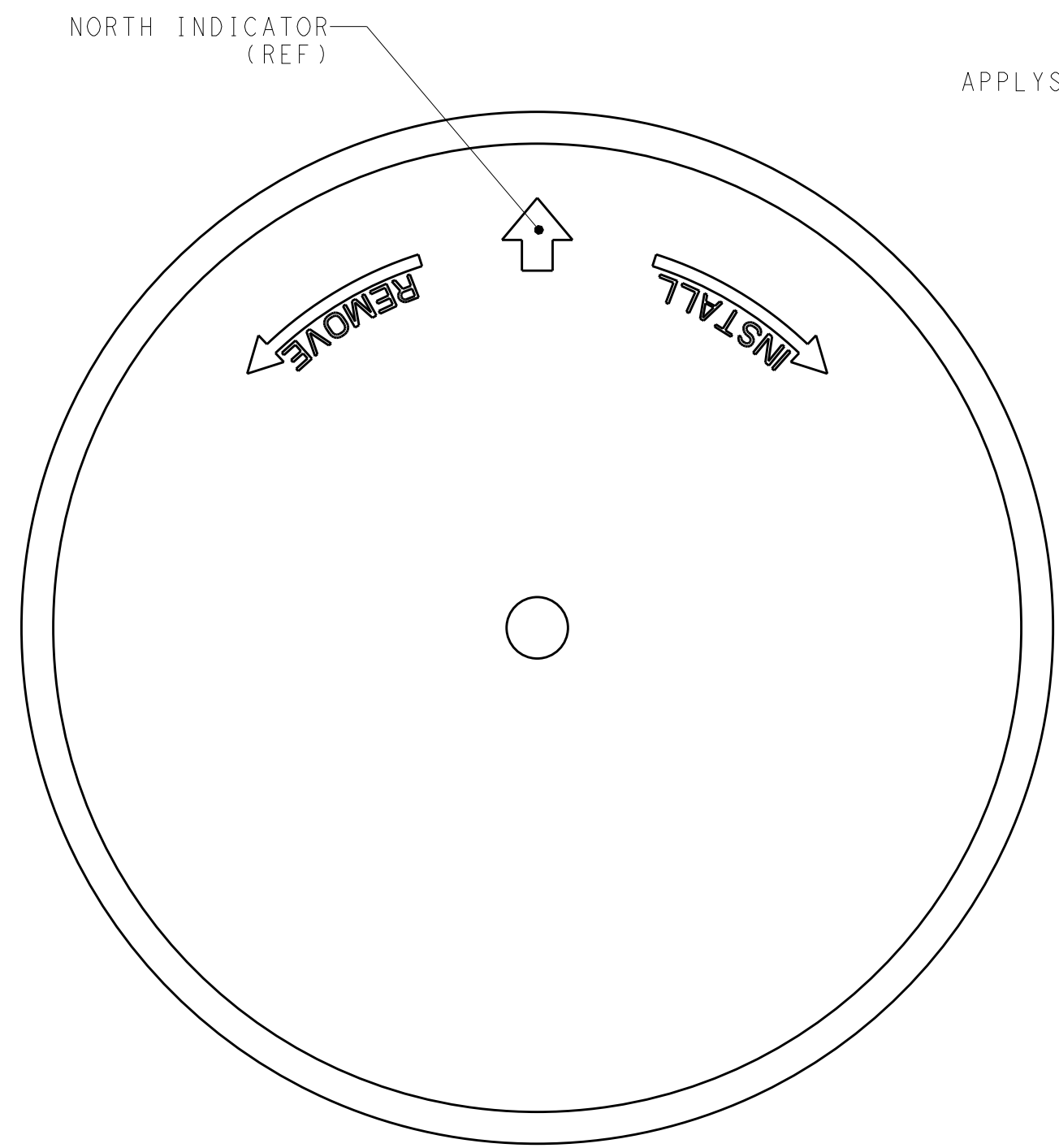

APPLYS TO SEALING ZONE

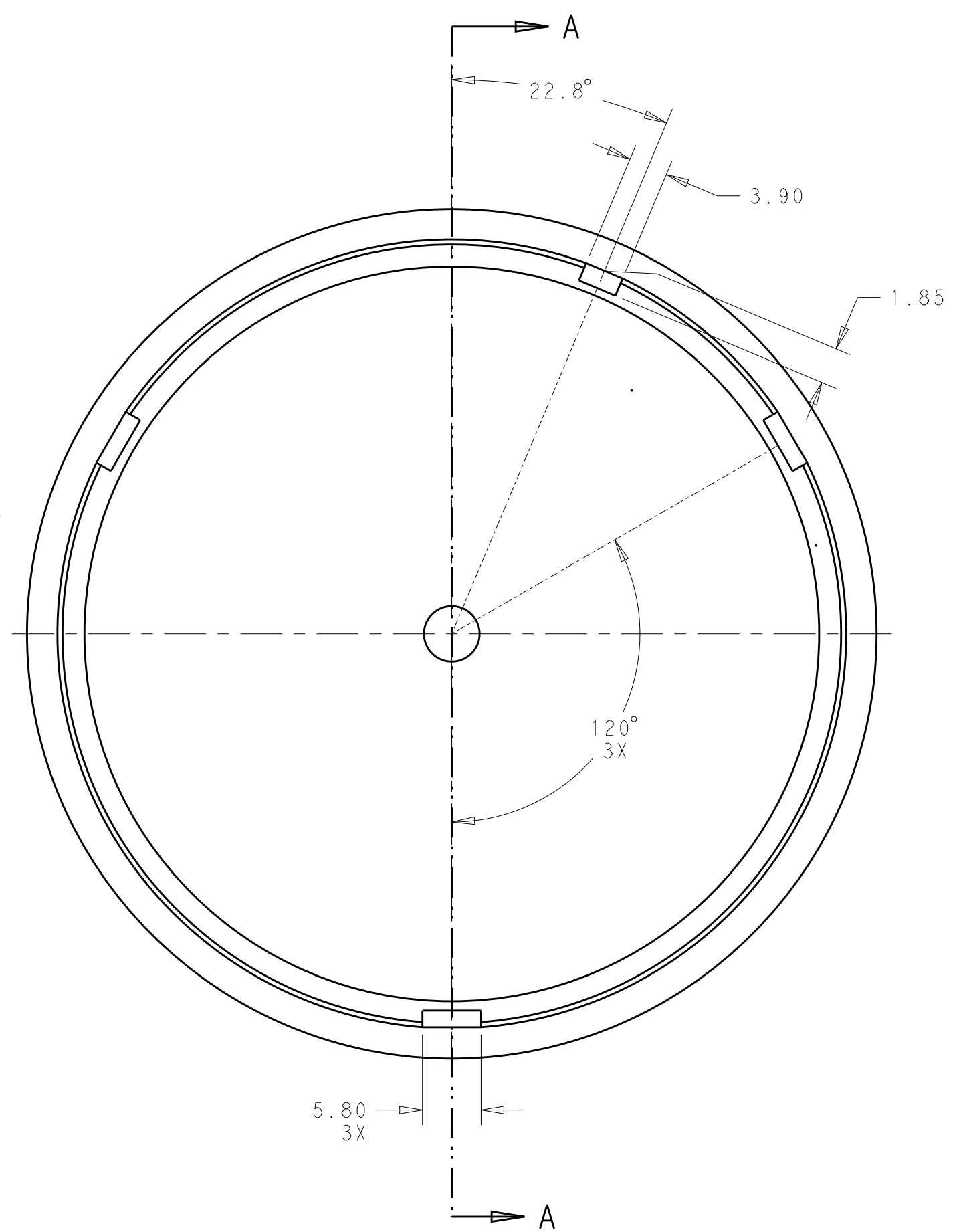
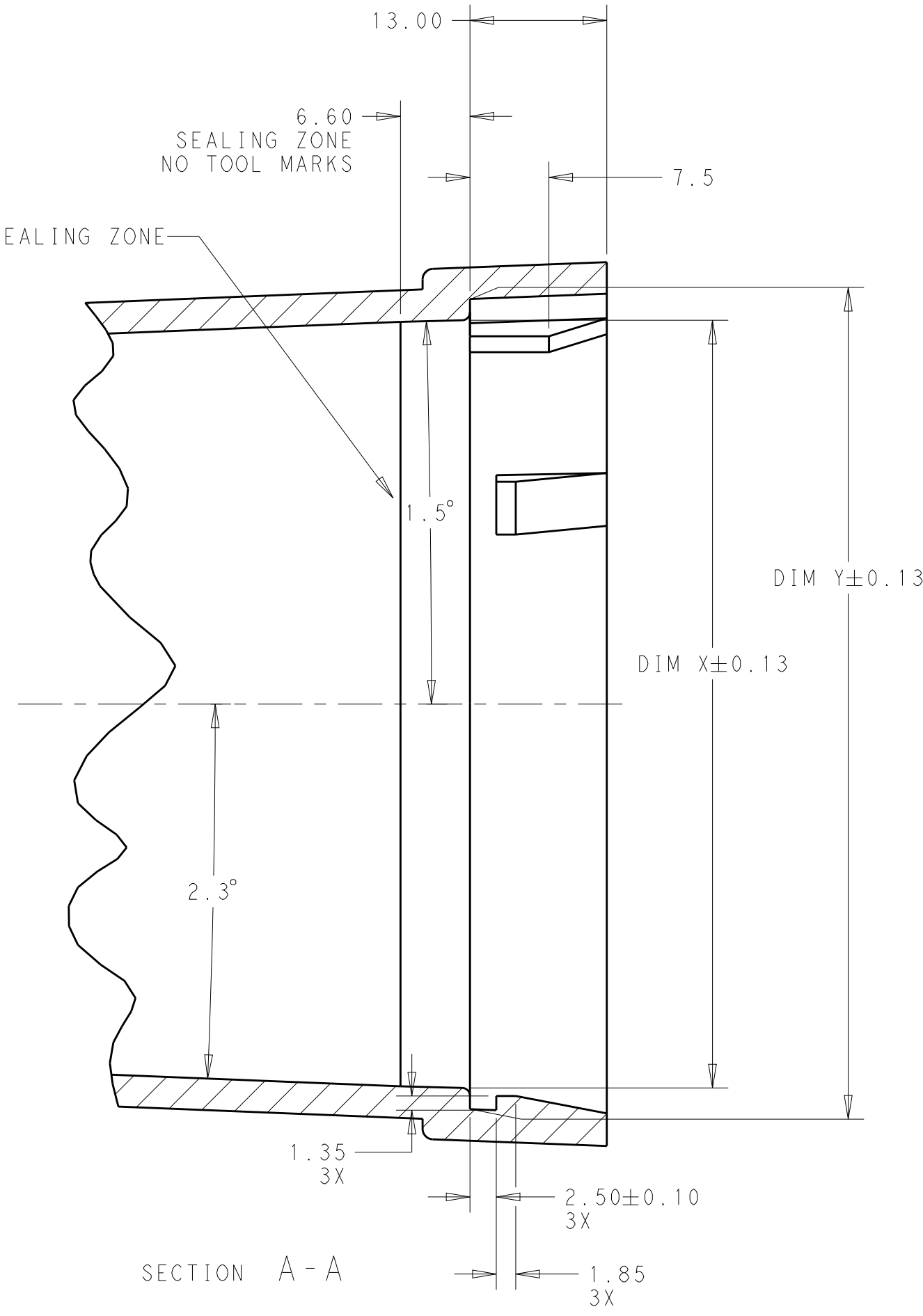

MATING COVER DIMENSIONS
 FOR
 76MM DIAMETER BASES
 (2336396-1, 1-2336396-1)

THIS DRAWING IS A CONTROLLED DOCUMENT.		DWN J. SHAFFER 03MAY2018	TE Connectivity		
		CHK M. MOSTOLLER 03MAY2018			
DIMENSIONS: mm		TOLERANCES UNLESS OTHERWISE SPECIFIED: 0 PLC ± 1 PLC ±0.2 2 PLC ±0.13 3 PLC ± 4 PLC ± ANGLES ±3° FINISH -		APVD - PRODUCT SPEC 108-32125 APPLICATION SPEC 114-32159 WEIGHT - CUSTOMER DRAWING	NAME BASE ASSEMBLY, LIGHT CONTROLLER, SLEEVE COMPATIBLE SIZE A2 CAGE CODE - DRAWING NO C-2336396 RESTRICTED TO -
MATERIAL -		SCALE 2:1		SHEET 4 OF 5	REV A2

THIS DRAWING IS UNPUBLISHED. RELEASED FOR PUBLICATION 20
 © COPYRIGHT 20 BY - ALL RIGHTS RESERVED.

REVISIONS				
P	LTR	DESCRIPTION	DATE	APVD
-	-	SEE SHEET 1	-	-

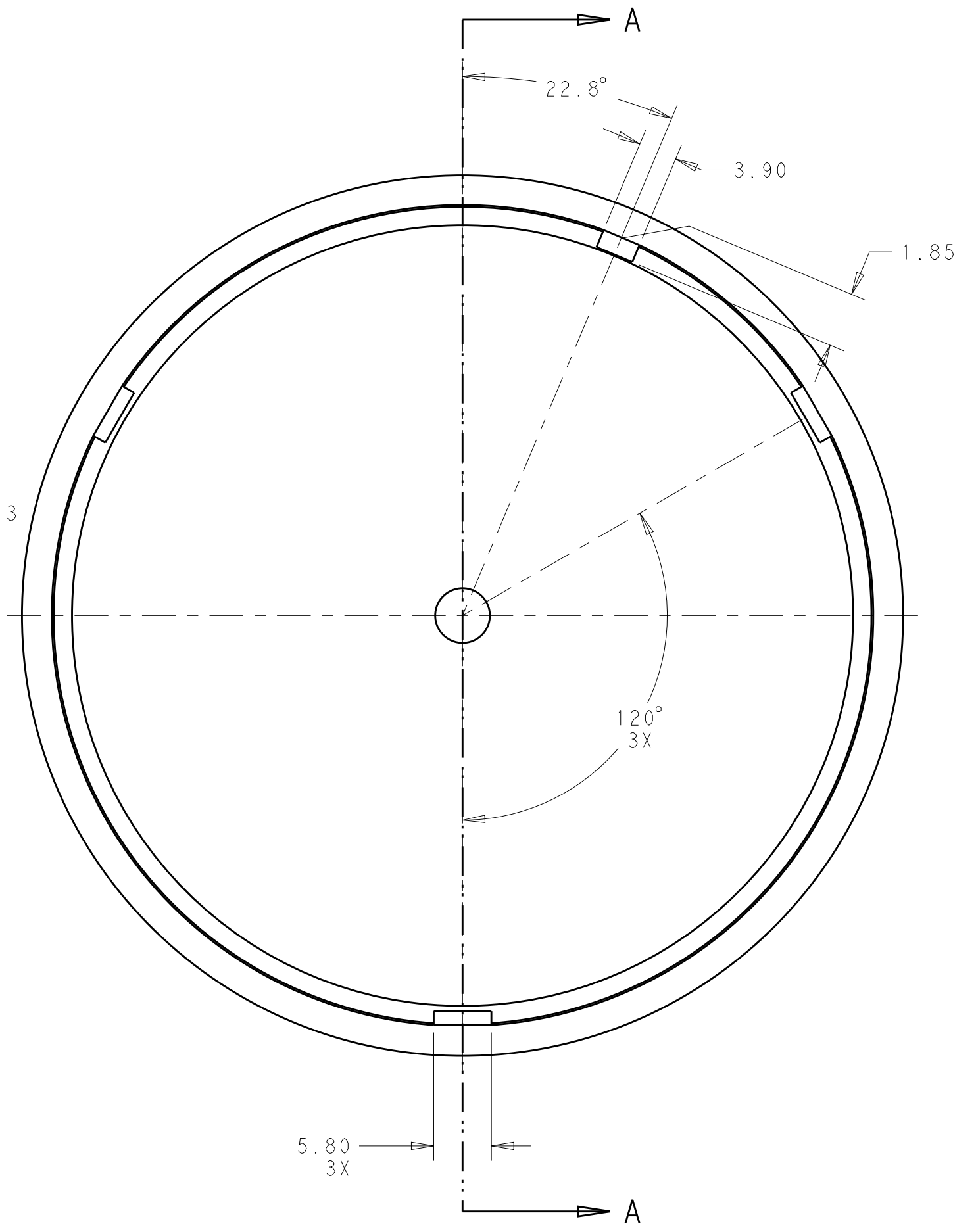
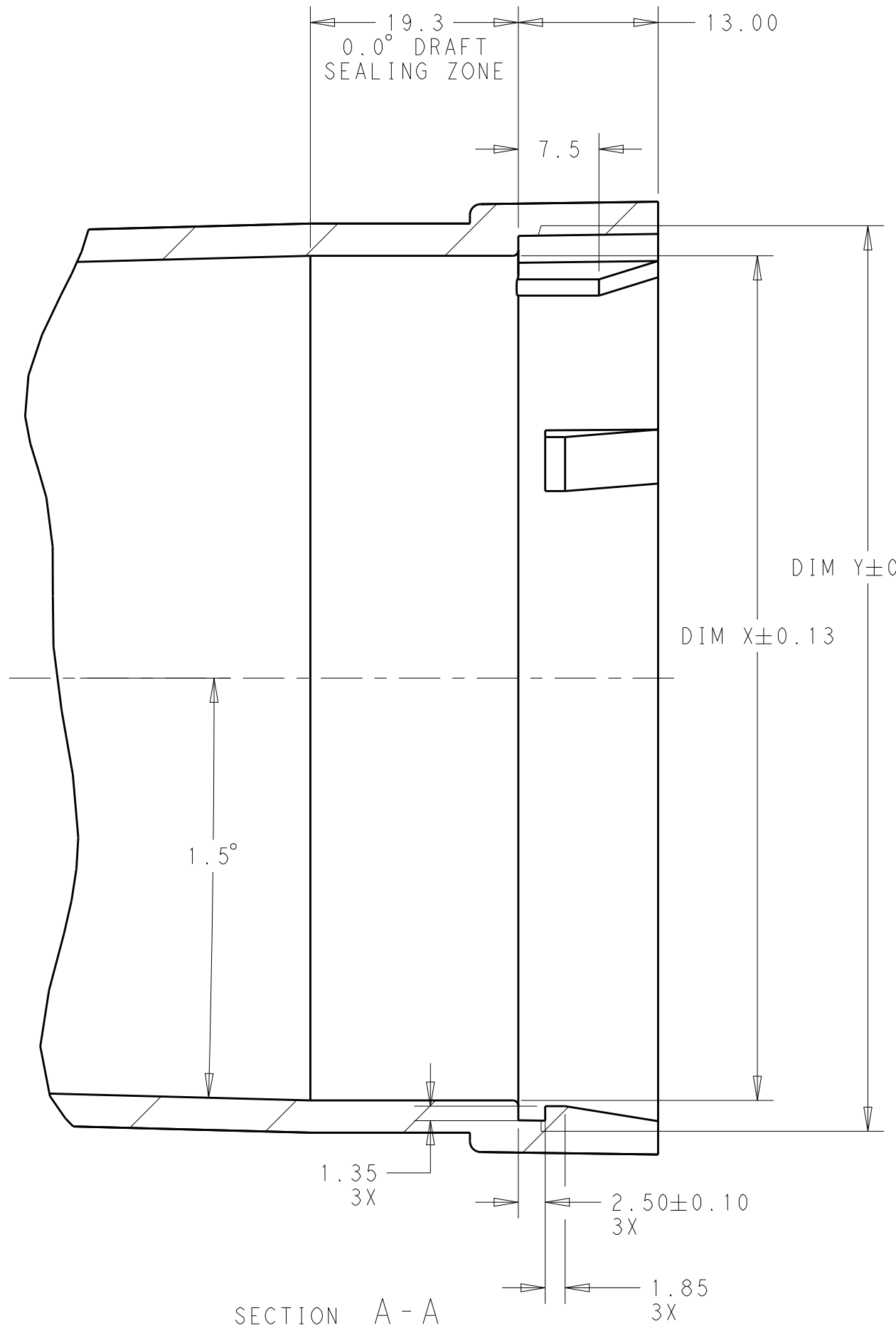
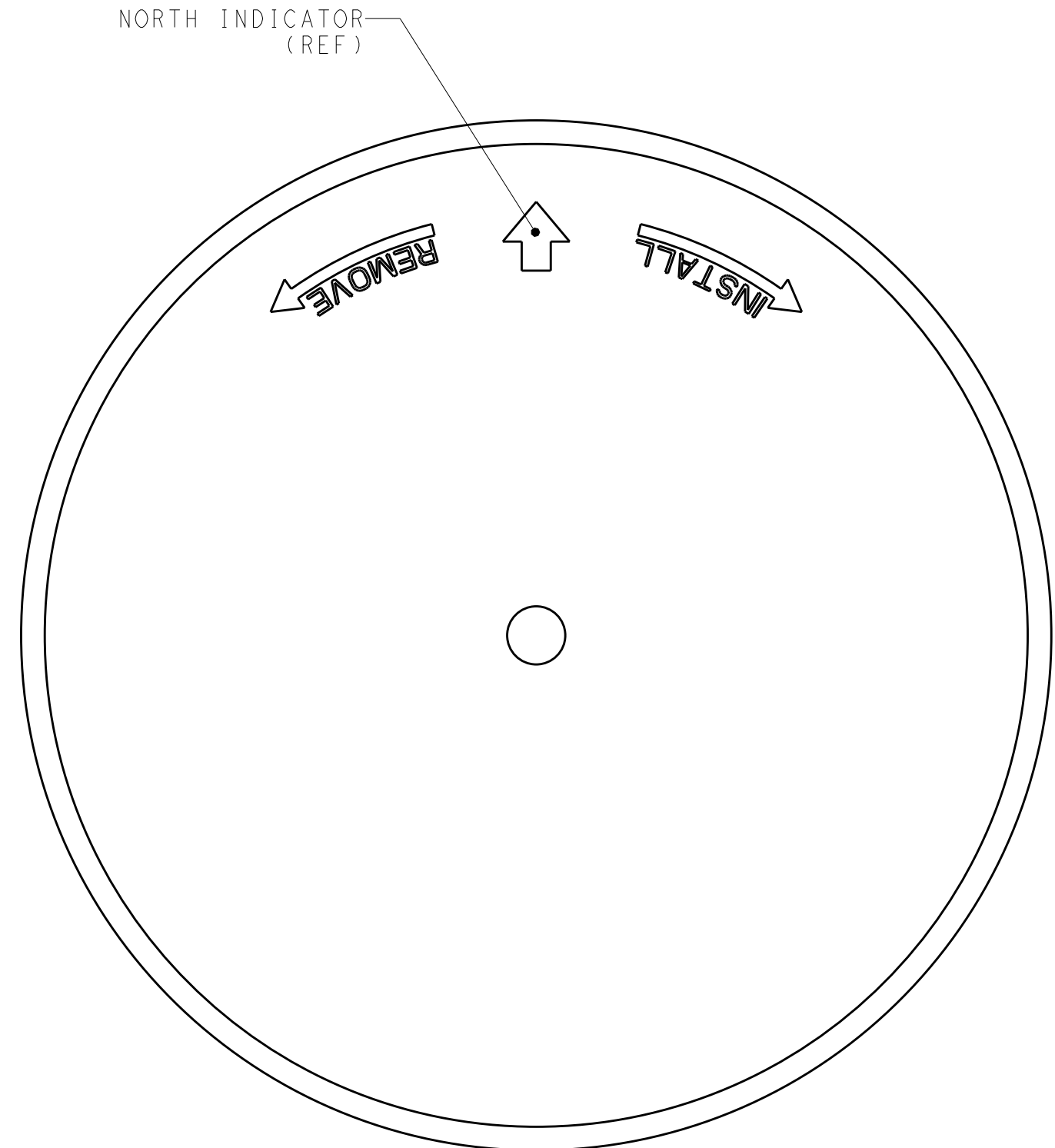

MATING COVER DIMENSIONS
 FOR
 81MM DIAMETER BASES
 (2336396-2, 1-2336396-2)

THIS DRAWING IS A CONTROLLED DOCUMENT.		DWN J. SHAFFER 03MAY2018	TE Connectivity	
		CHK M. MOSTOLLER 03MAY2018		
DIMENSIONS: mm		TOLERANCES UNLESS OTHERWISE SPECIFIED: 0 PLC ± 1 PLC ±0.2 2 PLC ±0.13 3 PLC ± 4 PLC ± ANGLES ±3° FINISH -		NAME BASE ASSEMBLY, LIGHT CONTROLLER, SLEEVE COMPATIBLE
MATERIAL -		PRODUCT SPEC 108-32125 APPLICATION SPEC 114-32159 WEIGHT -		SIZE A2
		CUSTOMER DRAWING		DRAWING NO C-2336396 RESTRICTED TO -
		SCALE 2:1		SHEET 5 OF 5 REV A2



Компания «ЭлектроПласт» предлагает заключение долгосрочных отношений при поставках импортных электронных компонентов на взаимовыгодных условиях!

Наши преимущества:

- Оперативные поставки широкого спектра электронных компонентов отечественного и импортного производства напрямую от производителей и с крупнейших мировых складов;
- Поставка более 17-ти миллионов наименований электронных компонентов;
- Поставка сложных, дефицитных, либо снятых с производства позиций;
- Оперативные сроки поставки под заказ (от 5 рабочих дней);
- Экспресс доставка в любую точку России;
- Техническая поддержка проекта, помощь в подборе аналогов, поставка прототипов;
- Система менеджмента качества сертифицирована по Международному стандарту ISO 9001;
- Лицензия ФСБ на осуществление работ с использованием сведений, составляющих государственную тайну;
- Поставка специализированных компонентов (Xilinx, Altera, Analog Devices, Intersil, Interpoint, Microsemi, Aeroflex, Peregrine, Syfer, Eurofarad, Texas Instrument, Miteq, Cobham, E2V, MA-COM, Hittite, Mini-Circuits, General Dynamics и др.);

Помимо этого, одним из направлений компании «ЭлектроПласт» является направление «Источники питания». Мы предлагаем Вам помощь Конструкторского отдела:

- Подбор оптимального решения, техническое обоснование при выборе компонента;
- Подбор аналогов;
- Консультации по применению компонента;
- Поставка образцов и прототипов;
- Техническая поддержка проекта;
- Защита от снятия компонента с производства.



Как с нами связаться

Телефон: 8 (812) 309 58 32 (многоканальный)

Факс: 8 (812) 320-02-42

Электронная почта: org@eplast1.ru

Адрес: 198099, г. Санкт-Петербург, ул. Калинина, дом 2, корпус 4, литера А.