

PRODUCT NUMBER
SEE SHEET 3

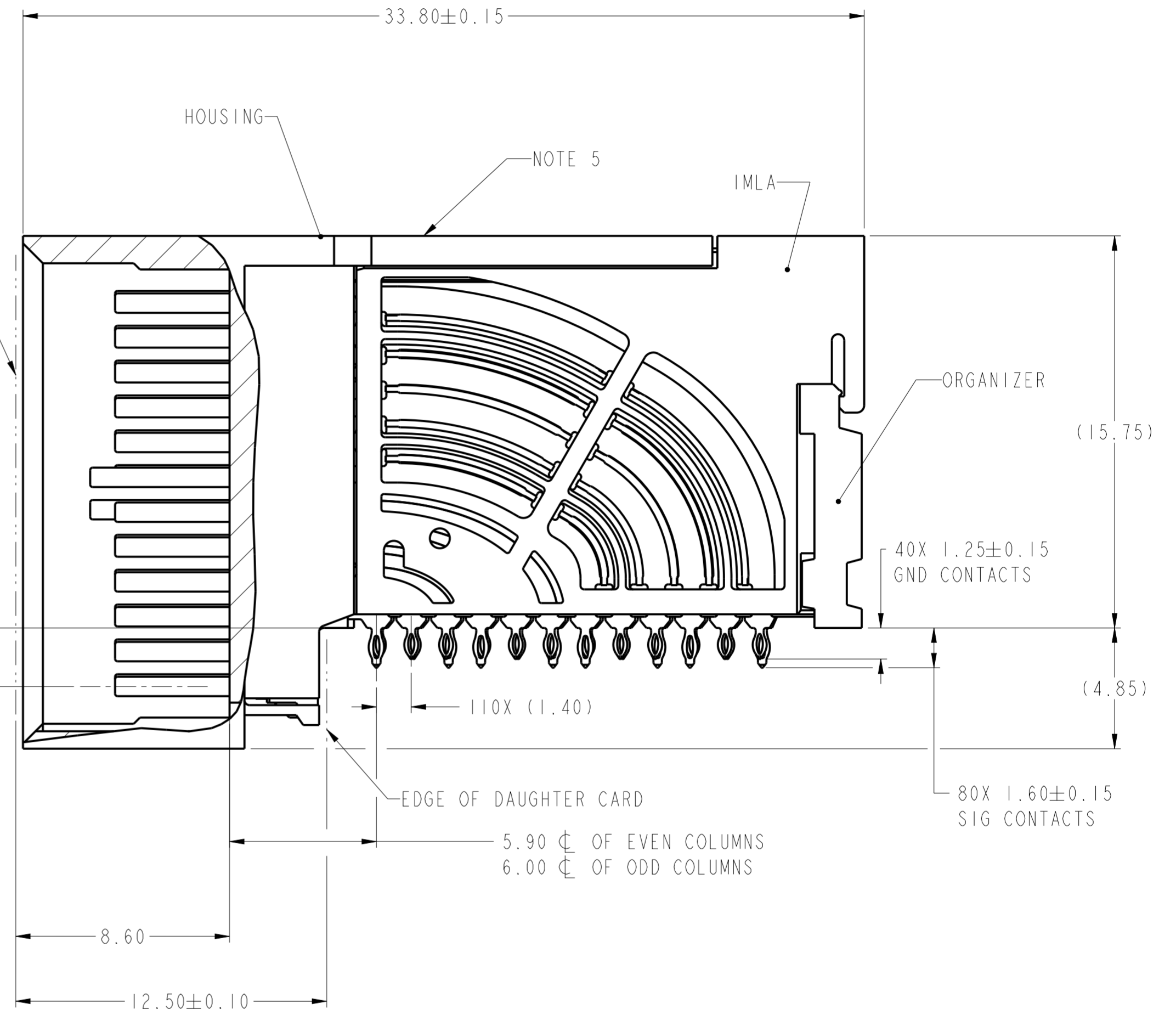
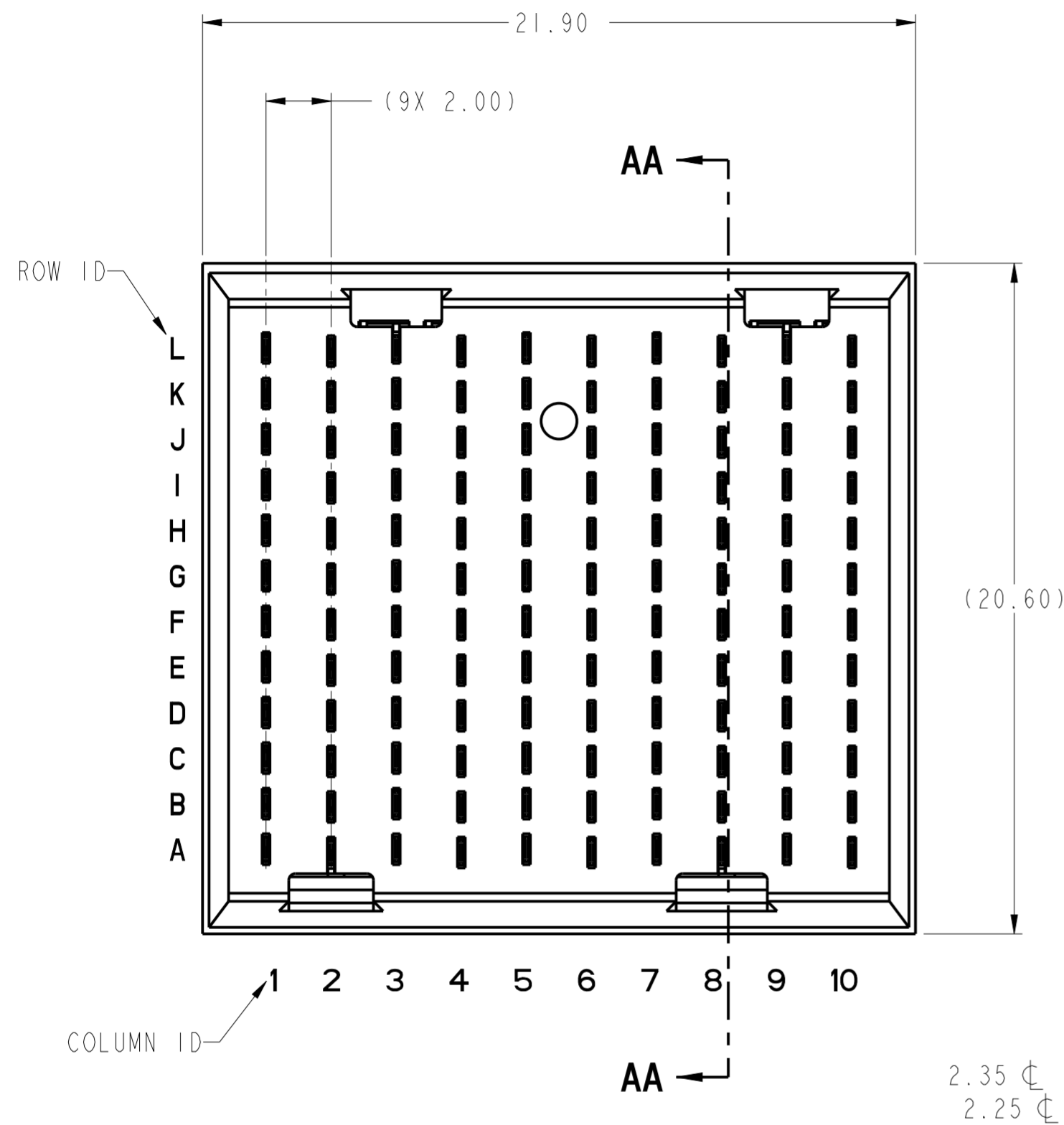

SECTION AA-AA

spec ref	---	dr	Lin-Soe Ngwe	2013/01/23	projection	MM	size	A2	scale	10:1										
tolerance std	ASME Y14.5M	eng	Art Lin	2016/11/01			ecn no	ELX-DG-2525-1												
TOLERANCES UNLESS OTHERWISE SPECIFIED		chr	Heaven Cen	2016/11/17			rel level	Released												
surface	<table border="1"> <tr> <td>linear</td> <td>0.X</td> <td>±.3</td> </tr> <tr> <td></td> <td>0.XX</td> <td>±.10</td> </tr> <tr> <td></td> <td>0.XXX</td> <td>±.050</td> </tr> <tr> <td>angular</td> <td>0°</td> <td>±2°</td> </tr> </table>	linear	0.X	±.3		0.XX	±.10		0.XXX	±.050	angular	0°	±2°	appr	Pai-Ming Zheng	2016/11/18	product family			
linear	0.X	±.3																		
	0.XX	±.10																		
	0.XXX	±.050																		
angular	0°	±2°																		
		Amphenol FCI www.fci.com		AirMax VS2 R.A. HEADER 4 Pair, 120 pos, 2mm, 10Col, Small Press Fit		cat. no. Product - Customer Draw	dwg no 10124150	rev D	sheet 1 of 3											

Amphenol FCI

© 2016 APCI

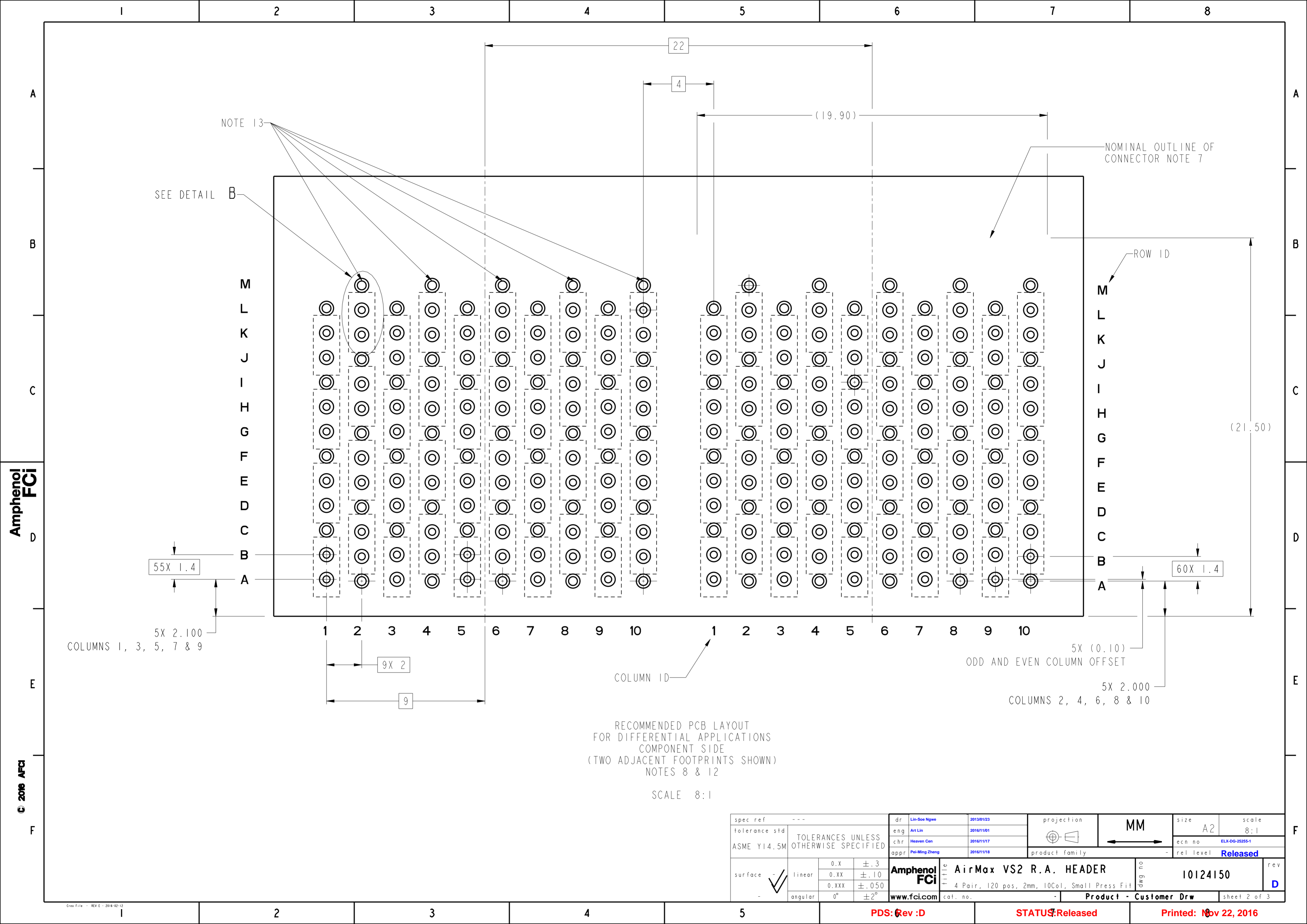

NOTE 13

SEE DETAIL B

NOMINAL OUTLINE OF CONNECTOR NOTE 7

ROW ID

M
L
K
J
I
H
G
F
E
D
C
B
A

M
L
K
J
I
H
G
F
E
D
C
B
A

1 2 3 4 5 6 7 8 9 10 1 2 3 4 5 6 7 8 9 10

5X 2.100
COLUMNS 1, 3, 5, 7 & 9

5X (0.10)
ODD AND EVEN COLUMN OFFSET

5X 2.000
COLUMNS 2, 4, 6, 8 & 10

9X 2

9

COLUMN ID

RECOMMENDED PCB LAYOUT
FOR DIFFERENTIAL APPLICATIONS
COMPONENT SIDE
(TWO ADJACENT FOOTPRINTS SHOWN)
NOTES 8 & 12

SCALE 8:1

spec ref	---	dr	Lin-Soe Ngwe	2013/01/23	projection	MM	size	A2	scale	8:1										
tolerance std	ASME Y14.5M	eng	Art Lin	2016/11/01			ecn no	ELX-DG-2525-1												
TOLERANCES UNLESS OTHERWISE SPECIFIED		chr	Heaven Cen	2016/11/17			rel level	Released												
surface	<table border="1"> <tr> <td>linear</td> <td>0.X</td> <td>±.3</td> </tr> <tr> <td></td> <td>0.XX</td> <td>±.10</td> </tr> <tr> <td></td> <td>0.XXX</td> <td>±.050</td> </tr> <tr> <td>angular</td> <td>0°</td> <td>±2°</td> </tr> </table>	linear	0.X	±.3		0.XX	±.10		0.XXX	±.050	angular	0°	±2°	appr	Pei-Ming Zheng	2016/11/18	product family			
linear	0.X	±.3																		
	0.XX	±.10																		
	0.XXX	±.050																		
angular	0°	±2°																		
				AirMax VS2 R.A. HEADER 4 Pair, 120 pos, 2mm, 10Col, Small Press Fit		dwg no 10124150	rev D													
		www.fci.com		cat. no.		Product - Customer Drw		sheet 2 of 3												

PDS: Rev :D

STATUS: Released

Printed: Nov 22, 2016

Amphenol FCI

© 2016 APCI

PRODUCT NUMBER	PRESS-FIT TAIL PLATING TYPE	REMARK
10124150 -101	TIN/LEAD ALLOY OVER NICKEL	1-SIDE PLATING (CUSTOMER SPECIAL)
10124150-101LF	TIN OVER NICKEL (LEAD FREE)	
10124150-102	TIN/LEAD ALLOY OVER NICKEL	2-SIDES PLATING
10124150-102LF	TIN OVER NICKEL (LEAD FREE)	

- 1 - CONNECTOR MATERIALS:
HOUSING: HIGH TEMP THERMOPLASTIC, NATURAL UL94-V0
IMLA PLASTIC: HIGH TEMP THERMOPLASTIC, BLACK, UL94-V0
CONTACT: COPPER ALLOY
ORGANIZER: HIGH TEMP THERMOPLASTIC, NATURAL, UL94-V0
- 2 - CONTACT PLATING:
SEPARABLE INTERFACE:
GXT PLUS PLATING, QUALIFIED TO MEET THE REQUIREMENTS OF FCI PRODUCT SPECIFICATION GS-12-0956 INCLUDING TELCORDIA GR-1217-CORE (NOVEMBER 1995) CENTRAL OFFICE TEST SEQUENCE
- PRESS-FIT TAILS: SEE TABLE
- 3 - PRODUCT SPECIFICATION: GS-12-0956
- 4 - APPLICATION SPECIFICATION: GS-20-0305
- 5 - PRODUCT MARKING, (PROTOTYPE, PART NUMBER & LOT CODE), ON THIS SURFACE.
- 6 - POSITIONS "F" OF ODD NUMBERED COLUMNS AND POSITIONS "G" OF EVEN NUMBERED COLUMNS CORRESPOND TO EARLY MATE HEADER PINS.
- 7 - CONNECTOR OUTLINE MAY BE SCREEN PRINTED ONTO CUSTOMER PCB TO BE USED AS A GUIDE FOR CONNECTOR PLACEMENT.
- 8 - REFER TO CUSTOMER DRAWING 10104444 FOR INFORMATION ON PCB HOLE DIAMETERS AND PLATING OPTIONS
- 9 - LEAD FREE PRODUCT MEETS THE EUROPEAN UNION DIRECTIVES & OTHER COUNTRY REGULATIONS AS DESCRIBED IN GS-22-008
- 10 - A \triangle SYMBOL WILL BE NEXT TO ANY DIMENSION, VIEW OR NOTE, WHICH HAS BEEN MODIFIED WITH THE CURRENT DRAWING REVISION.
- 11 - PACKAGING MEETS GS-14-920 LEAD FREE LABELING SPECIFICATION.
- 12 - GROUND CONTACTS (C, F, I & L IN ODD COLUMNS AND A, D, G & J IN EVEN COLUMNS) REQUIRE ($\varnothing 0.50$) FINISHED HOLES. SIGNAL LOCATIONS REQUIRE ($\varnothing 0.40$) FINISHED HOLES
- 13 - THESE OUTER VIAS (M) ARE OPTIONAL. WHILE NO CONNECTOR PINS ARE PRESSED INTO THESE HOLES WE RECOMMEND ($\varnothing 0.500$) FINISHED HOLES AT THESE LOCATIONS TO PROVIDE GROUND SYMMETRY THROUGH THE PCB.

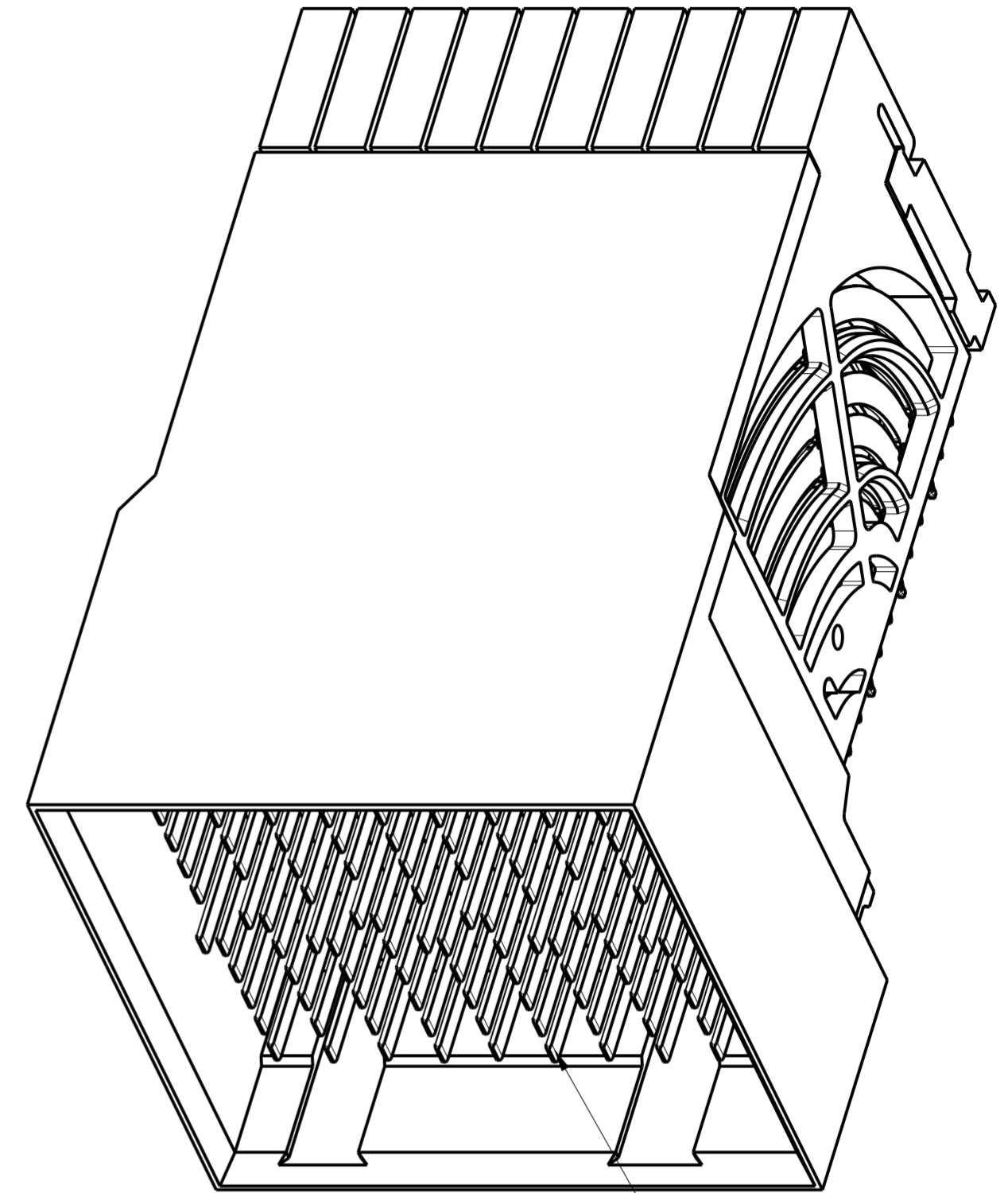

10124150-101 OR -101LF
10124150-102 OR -102LF

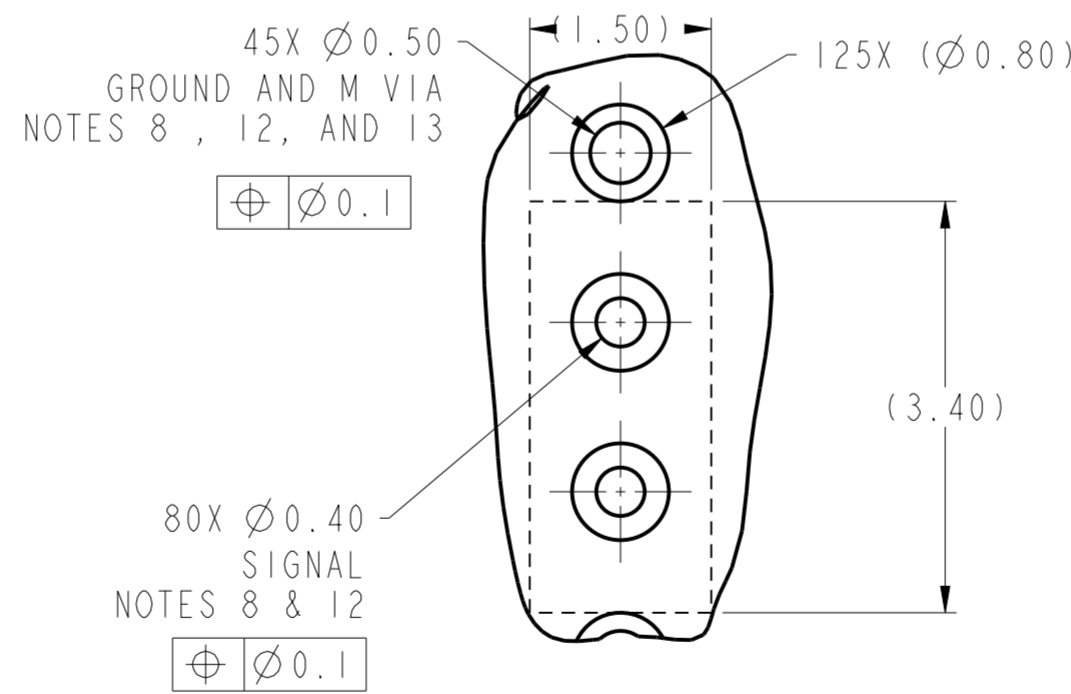

DETAIL B
SCALE 16:1

spec ref	---	dr	Lin-Soe Ngwe	2013/01/23	projection	MM	size	A2	scale	10:1										
tolerance std	ASME Y14.5M	eng	Art Lin	2016/11/01			ecn no	ELX-DG-25255-1												
TOLERANCES UNLESS OTHERWISE SPECIFIED		chr	Heaven Cen	2016/11/17			rel level	Released												
surface	<table border="1"> <tr> <td>linear</td> <td>0.X</td> <td>±.3</td> </tr> <tr> <td></td> <td>0.XX</td> <td>±.10</td> </tr> <tr> <td></td> <td>0.XXX</td> <td>±.050</td> </tr> <tr> <td>angular</td> <td>0°</td> <td>±2°</td> </tr> </table>	linear	0.X	±.3		0.XX	±.10		0.XXX	±.050	angular	0°	±2°	appr	Pei-Ming Zheng	2016/11/18	product family			
linear	0.X	±.3																		
	0.XX	±.10																		
	0.XXX	±.050																		
angular	0°	±2°																		
		Amphenol FCI www.fci.com		title AirMax VS2 R.A. HEADER 4 Pair, 120 pos, 2mm, 10Col, Small Press Fit		dwg no 10124150		rev D		Product - Customer Drw sheet 3 of 3										



Компания «ЭлектроПласт» предлагает заключение долгосрочных отношений при поставках импортных электронных компонентов на взаимовыгодных условиях!

Наши преимущества:

- Оперативные поставки широкого спектра электронных компонентов отечественного и импортного производства напрямую от производителей и с крупнейших мировых складов;
- Поставка более 17-ти миллионов наименований электронных компонентов;
- Поставка сложных, дефицитных, либо снятых с производства позиций;
- Оперативные сроки поставки под заказ (от 5 рабочих дней);
- Экспресс доставка в любую точку России;
- Техническая поддержка проекта, помощь в подборе аналогов, поставка прототипов;
- Система менеджмента качества сертифицирована по Международному стандарту ISO 9001;
- Лицензия ФСБ на осуществление работ с использованием сведений, составляющих государственную тайну;
- Поставка специализированных компонентов (Xilinx, Altera, Analog Devices, Intersil, Interpoint, Microsemi, Aeroflex, Peregrine, Syfer, Eurofarad, Texas Instrument, Miteq, Cobham, E2V, MA-COM, Hittite, Mini-Circuits, General Dynamics и др.);

Помимо этого, одним из направлений компании «ЭлектроПласт» является направление «Источники питания». Мы предлагаем Вам помощь Конструкторского отдела:

- Подбор оптимального решения, техническое обоснование при выборе компонента;
- Подбор аналогов;
- Консультации по применению компонента;
- Поставка образцов и прототипов;
- Техническая поддержка проекта;
- Защита от снятия компонента с производства.



Как с нами связаться

Телефон: 8 (812) 309 58 32 (многоканальный)

Факс: 8 (812) 320-02-42

Электронная почта: org@eplast1.ru

Адрес: 198099, г. Санкт-Петербург, ул. Калинина, дом 2, корпус 4, литера А.