

ISL95852

Integrated Power Management IC for IMVP8™ Platforms

FN8731
Rev 1.00
May 5, 2016

The [ISL95852](#) is a Power Management Integrated Circuit (PMIC) for ultrabook, notebook and tablet computers powered by 2-cell Li-ion batteries. It integrates control, MOSFET drivers, power MOSFETs, fault protection and fault monitoring functions for three highly efficient synchronous buck regulators. Integrated into one package are the regulators for the core, graphics and system agent voltages. The ISL95852 is offered in a thermally efficient 4mmx4mm, 64 bump, 0.5mm pitch WLCSP package.

The PMIC regulators convert the system voltage from a battery or adapter into the three necessary processor voltages required by Intel's IMVP8 specifications. The switching regulators operate at high frequency and are based on Intersil's proprietary R3™ Technology, which provides high light-load efficiency and fast transient response with minimal external compensation.

The PMIC provides overcurrent, overvoltage and over-temperature fault protections. Also provided is a temperature alert signal indicating the PMIC is operating at elevated temperature and an ALERT signal indicates if any other fault or warning has occurred. The PMIC also offers I²C capability compatible with Intel's SMBus specification.

Features

- Highly integrated power management IC
- Efficient high frequency integrated FET switching regulators
- Integrated regulators to produce core, graphics and system agent rails
- Extensive fault protection
 - Overcurrent, overvoltage and over-temperature protection
 - Temperature alert signal
- SVID I²C bus allows system fault monitoring, enable control
- Output voltage offset programming through SVID I²C

Applications

- Ultrabook, notebook and tablet computers

Related Literature

- [TB451](#), "PCB Assembly Guidelines for Intersil Wafer Level Chip Scale Package Devices"
- [TB500](#), "Computing Power Reference Design Adaptation Guide"
- [TB501](#), "Computing Power Regulator Layout Checklist"
- [UG041](#), "ISL95852EVAL1Z Evaluation Board User Guide"

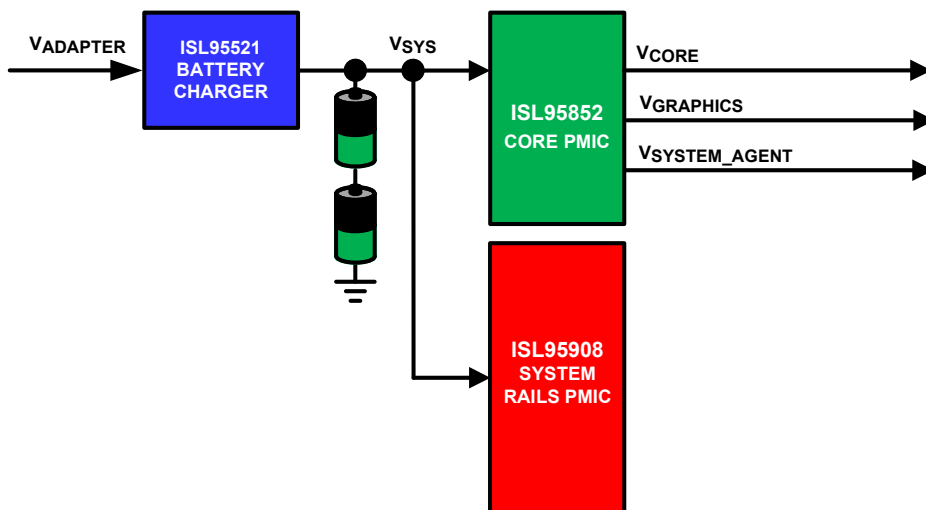

FIGURE 1. COMPUTER SYSTEM POWER MANAGEMENT SOLUTION

© Copyright Intersil Americas LLC 2015-2016. All Rights Reserved.
All trademarks and registered trademarks are the property of their respective owners.

For additional products, see www.intersil.com/en/products.html

Intersil products are manufactured, assembled and tested utilizing ISO9001 quality systems as noted in the quality certifications found at www.intersil.com/en/support/qualandreliability.html

Intersil products are sold by description only. Intersil may modify the circuit design and/or specifications of products at any time without notice, provided that such modification does not, in Intersil's sole judgment, affect the form, fit or function of the product. Accordingly, the reader is cautioned to verify that datasheets are current before placing orders. Information furnished by Intersil is believed to be accurate and reliable. However, no responsibility is assumed by Intersil or its subsidiaries for its use; nor for any infringements of patents or other rights of third parties which may result from its use. No license is granted by implication or otherwise under any patent or patent rights of Intersil or its subsidiaries.

For information regarding Intersil Corporation and its products, see www.intersil.com



Компания «ЭлектроПласт» предлагает заключение долгосрочных отношений при поставках импортных электронных компонентов на взаимовыгодных условиях!

Наши преимущества:

- Оперативные поставки широкого спектра электронных компонентов отечественного и импортного производства напрямую от производителей и с крупнейших мировых складов;
- Поставка более 17-ти миллионов наименований электронных компонентов;
- Поставка сложных, дефицитных, либо снятых с производства позиций;
- Оперативные сроки поставки под заказ (от 5 рабочих дней);
- Экспресс доставка в любую точку России;
- Техническая поддержка проекта, помощь в подборе аналогов, поставка прототипов;
- Система менеджмента качества сертифицирована по Международному стандарту ISO 9001;
- Лицензия ФСБ на осуществление работ с использованием сведений, составляющих государственную тайну;
- Поставка специализированных компонентов (Xilinx, Altera, Analog Devices, Intersil, Interpoint, Microsemi, Aeroflex, Peregrine, Syfer, Eurofarad, Texas Instrument, Miteq, Cobham, E2V, MA-COM, Hittite, Mini-Circuits, General Dynamics и др.);

Помимо этого, одним из направлений компании «ЭлектроПласт» является направление «Источники питания». Мы предлагаем Вам помощь Конструкторского отдела:

- Подбор оптимального решения, техническое обоснование при выборе компонента;
- Подбор аналогов;
- Консультации по применению компонента;
- Поставка образцов и прототипов;
- Техническая поддержка проекта;
- Защита от снятия компонента с производства.



Как с нами связаться

Телефон: 8 (812) 309 58 32 (многоканальный)

Факс: 8 (812) 320-02-42

Электронная почта: org@eplast1.ru

Адрес: 198099, г. Санкт-Петербург, ул. Калинина, дом 2, корпус 4, литера А.