

High Voltage, Isolated MOSFET Driver

Features

- ▶ $\pm 400\text{V}$ input to output isolation
- ▶ Low input logic current, $500\mu\text{A}$ max
- ▶ No external voltage supply required
- ▶ Floating isolated output drivers
- ▶ 5.0V logic compatible

Applications

- ▶ Telecommunications
- ▶ Modems
- ▶ Solid state relays
- ▶ High side switches
- ▶ High end audio switches
- ▶ Avionics
- ▶ ATE

General Description

The Supertex HT0740 is a single channel, high voltage, low input current, isolated driver utilizing Supertex's proprietary HVCMOS[®] technology. It is designed to drive discrete MOSFETs, configured as high side switches, up to 400V. The HT0740 generates an independent DC isolated voltage across the pair of outputs when the logic input is at a logic high. The HT0740 does not require any external power supplies. The internal supply voltage is supplied from the logic input when it is in the high state.

Block Diagram

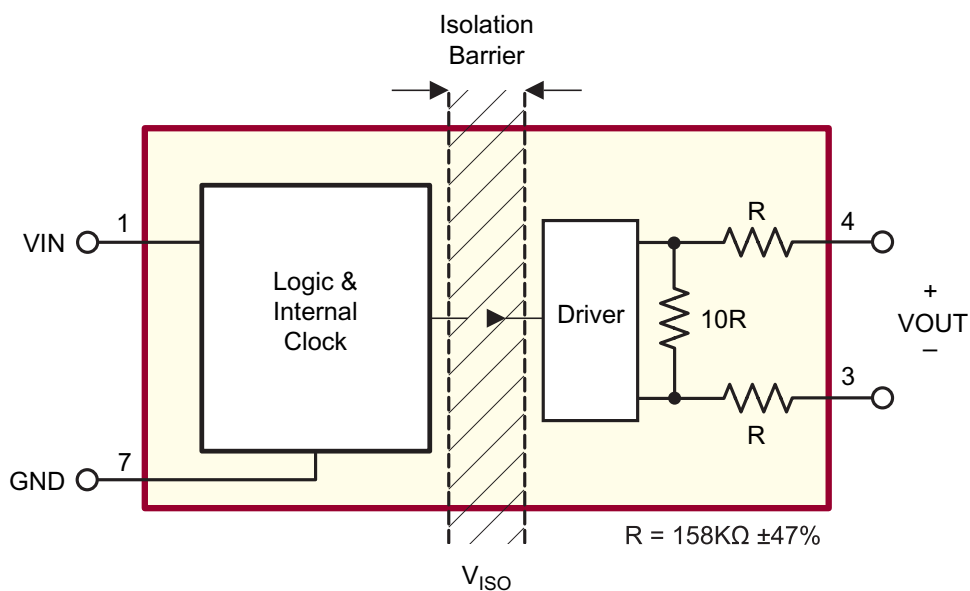

Ordering Information

Device	Package Options	
	8-Lead SOIC (Narrow Body)	
HT0740	HT0740LG	HT0740LG-G

-G indicates package is RoHS compliant ('Green')



Absolute Maximum Ratings

Parameter	Value
Input to output isolation voltage, V_{ISO}	$\pm 400V$
Logic input voltage, V_{IN}	-0.5 to +7.0V
Operating temperature	-40°C to +85°C
Storage temperature	-55°C to +150°C
Soldering temperature ¹	300°C

Absolute Maximum Ratings are those values beyond which damage to the device may occur. Functional operation under these conditions is not implied. Continuous operation of the device at the absolute rating level may affect device reliability. All voltages are referenced to device ground.

Note 1. Distance of 1.6mm from case for 10 seconds.

Pin Configuration

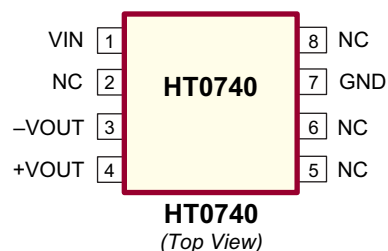

DC Electrical Characteristics ($T_J = -40^\circ\text{C}$ to $+85^\circ\text{C}$ unless otherwise specified)

Symbol	Parameter	Min	Typ	Max	Units	Conditions
I_H	Logic high input current	-	-	500	μA	$V_{IN} = 5.0V$
I_L	Logic low input current (quiescent)	-	-	10	μA	$V_{IN} = 0.5V$
V_{OUT}	Output voltage across output terminals	4.5	-	-	V	$V_{IN} = 3.15V$, no load
		8.5	-	-	V	$V_{IN} = 4.5V$, no load
V_{IN}	Input voltage for zero output	-	-	0.8	V	No load
V_{ISO}	Input to output isolation voltage	± 400	-	-	V	---

AC Electrical Characteristics

Symbol	Parameter	Min	Typ	Max	Units	Conditions
$t_{d(ON)}$	Turn-on delay time	-	-	50	μs	See timing diagram and test circuit $C_L = 600\text{pF}$, $T_A = 25^\circ\text{C}$
t_r	Rise time	-	-	650	μs	
$t_{d(OFF)}$	Turn-off delay time	-	-	150	μs	
t_f	Fall time	-	-	3.0	ms	

Recommended Operating Conditions

Symbol	Parameter	Min	Typ	Max	Units	Conditions
V_{IH}	Logic input high voltage	3.15	-	5.5	V	---
V_{IL}	Logic input low voltage	0	-	0.5	V	---
T_A	Operating temperature	-40	-	+85	$^\circ\text{C}$	---

Timing Diagram

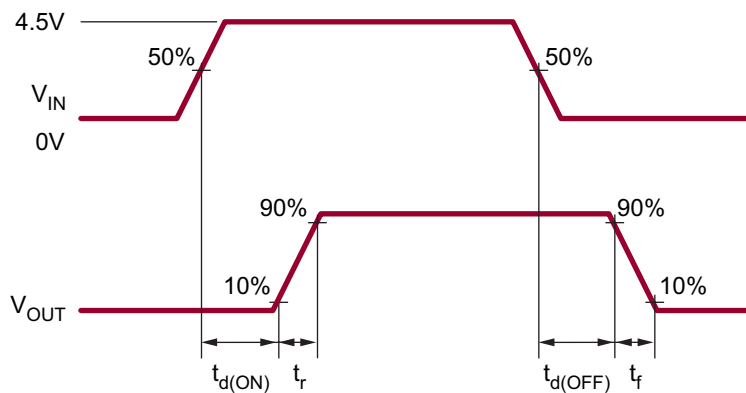

Test Circuit

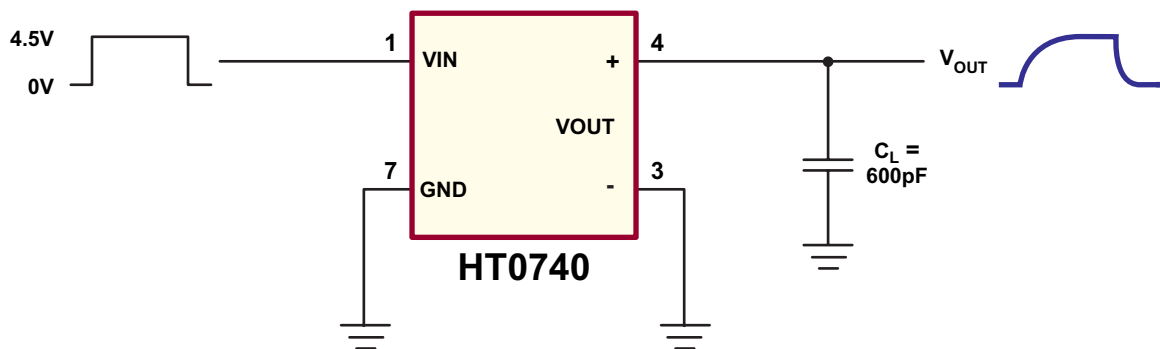

8-Lead SOIC (Narrow Body) LG Package Outline

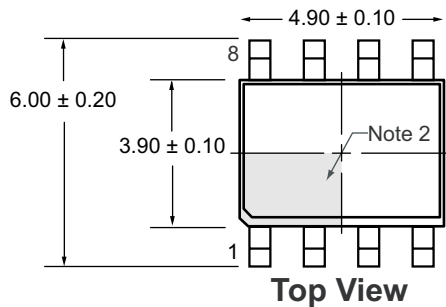

Notes:

1. All dimensions in millimeters. Angles in degrees.
2. If the corner is not chamfered, then a Pin 1 identifier must be located within the area indicated.

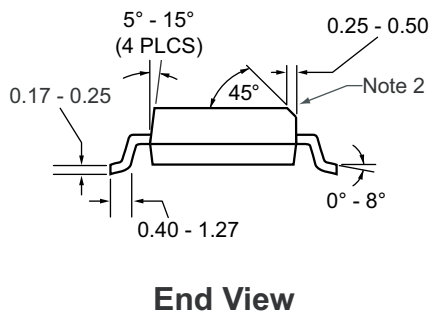
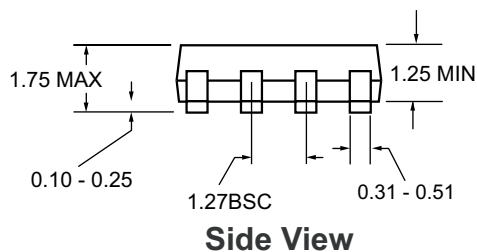

(The package drawing(s) in this data sheet may not reflect the most current specifications. For the latest package outline information go to <http://www.supertex.com/packaging.html>.)

Supertex inc. does not recommend the use of its products in life support applications, and will not knowingly sell its products for use in such applications, unless it receives an adequate "product liability indemnification insurance agreement". **Supertex** does not assume responsibility for use of devices described and limits its liability to the replacement of the devices determined defective due to workmanship. No responsibility is assumed for possible omissions or inaccuracies. Circuitry and specifications are subject to change without notice. For the latest product specifications, refer to the **Supertex** website: <http://www.supertex.com>.



Компания «ЭлектроПласт» предлагает заключение долгосрочных отношений при поставках импортных электронных компонентов на взаимовыгодных условиях!

Наши преимущества:

- Оперативные поставки широкого спектра электронных компонентов отечественного и импортного производства напрямую от производителей и с крупнейших мировых складов;
- Поставка более 17-ти миллионов наименований электронных компонентов;
- Поставка сложных, дефицитных, либо снятых с производства позиций;
- Оперативные сроки поставки под заказ (от 5 рабочих дней);
- Экспресс доставка в любую точку России;
- Техническая поддержка проекта, помощь в подборе аналогов, поставка прототипов;
- Система менеджмента качества сертифицирована по Международному стандарту ISO 9001;
- Лицензия ФСБ на осуществление работ с использованием сведений, составляющих государственную тайну;
- Поставка специализированных компонентов (Xilinx, Altera, Analog Devices, Intersil, Interpoint, Microsemi, Aeroflex, Peregrine, Syfer, Eurofarad, Texas Instrument, Miteq, Cobham, E2V, MA-COM, Hittite, Mini-Circuits, General Dynamics и др.);

Помимо этого, одним из направлений компании «ЭлектроПласт» является направление «Источники питания». Мы предлагаем Вам помощь Конструкторского отдела:

- Подбор оптимального решения, техническое обоснование при выборе компонента;
- Подбор аналогов;
- Консультации по применению компонента;
- Поставка образцов и прототипов;
- Техническая поддержка проекта;
- Защита от снятия компонента с производства.



Как с нами связаться

Телефон: 8 (812) 309 58 32 (многоканальный)

Факс: 8 (812) 320-02-42

Электронная почта: org@eplast1.ru

Адрес: 198099, г. Санкт-Петербург, ул. Калинина, дом 2, корпус 4, литера А.