

DESCRIPTION

Demonstration circuit 542 is a dual output, dual phase step down converter, which is controlled by the LTC3728EG. Output #1 can be configured for either 5.0V or 3.3V and output #2 can be configured for either 3.3V or 2.5V. The maximum load for both rails is 12A. The input voltage range of the DC542 is 8V to 24V.

The DC542 also contains a footprint for a 5.5V boost converter bias supply whose output is connected to EXTVCC. See the “Optional Bias Supply” section for more details.

Design files for this circuit board are available. Call the LTC factory.

Table 1. Performance Summary

PARAMETER	CONDITION	VALUE
Minimum Input Voltage		8V
Maximum Input Voltage		24V
V _{OUT1}	V _{IN} = 8V to 24V, I _{OUT} = 0A to 12A	5.0V ± 3% / 3.3V ± 3%
V _{OUT2}	V _{IN} = 8V to 24V, I _{OUT} = 0A to 12A	3.3V ± 3% / 2.5V ± 3%

QUICK START PROCEDURE

Demonstration circuit 542 is easy to set up. Refer to Figure 1 for the proper setup of the measurement equipment and follow the procedure below:

1. With power off, connect the input voltage source and the load. The load cables should be sized for 12 Amps and the input cables should be sized for 15 Amps.
2. The jumpers should be placed in their default positions as shown in Figure 1.
3. If a constant current electronic load is used, preset the load current to about 1A or less before applying power to the input. Otherwise, the foldback current limit function of the LTC3728 may be triggered during startup.
4. Apply power to the input and set the input voltage to 12V. The voltage for output #1 should be 5.0V ± 3% and the voltage for output #2 should be 3.3V ± 3%. Increase the load on both rails to 12.0A. The two outputs should still be within regulation.
5. Keep the input voltage at 12.0V and the load at 12.0A for both rails. Measure the DC input current. It should be less than 9.4A.
6. Remove input power from the converter. Set the voltage for output #1 to 3.3V using jumper JP5 and the voltage for output #2 to 2.5V using JP4. Repeat step #4. The voltage for output #1 should be 3.3V ± 3% and the voltage for output #2 should be 2.5V ± 3%.
7. Adjust the input voltage and load current to the desired levels within their limits and observe the regulation, output ripple, load step response, efficiency and other parameters.

QUICK START GUIDE FOR DEMONSTRATION CIRCUIT 542

DUAL PHASE, DUAL OUTPUT SYNCHRONOUS BUCK CONVERTER

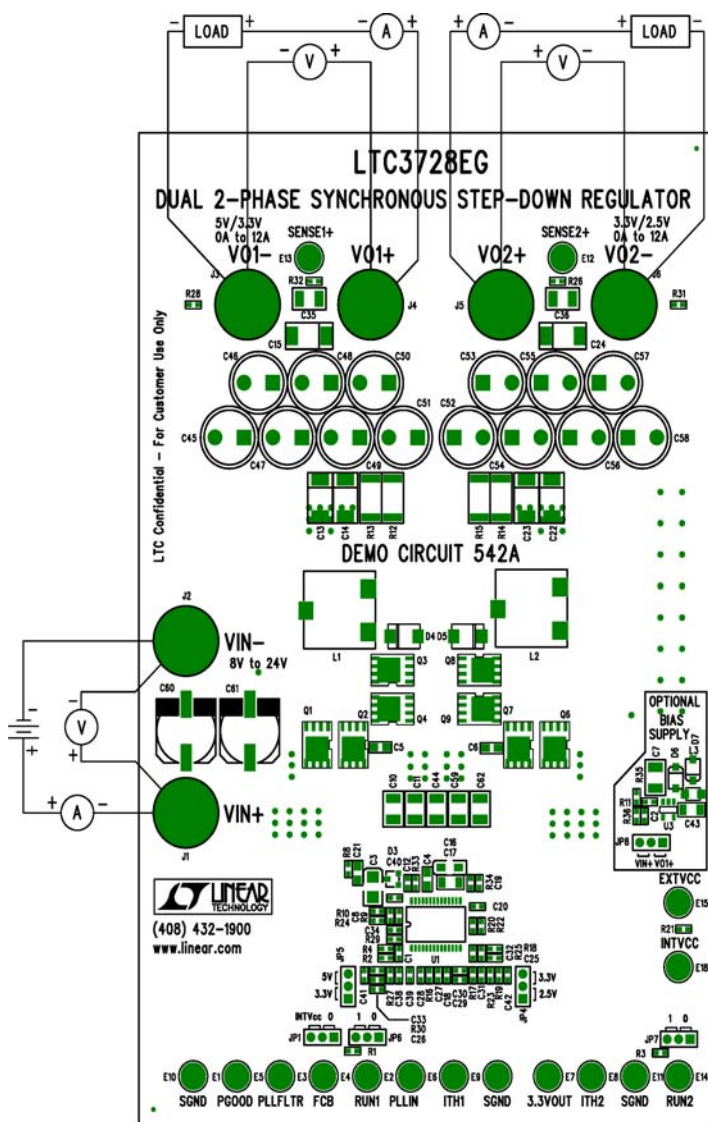

Figure 1. Setup for measurement equipment.

Note: When measuring the output voltage ripple, care must be taken to avoid a long ground lead on the oscilloscope probe. Connect the probe tip to VOUT and the probe's ground ring to GND. Make the connections as short as possible. For output #1, measure the ripple directly across C35 and for output #2, measure across C36. See Figure 2.

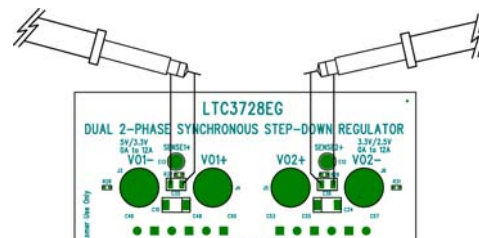

Figure 2. Output ripple measurement.

OPTIONAL BIAS SUPPLY

The DC542 also contains a footprint for a 5.5V boost converter bias supply whose output is connected to EXTVCC. The input of this bias supply can be connected to one of the following:

- 1) VIN, if $V_{IN} < 5V$
- 2) VOUT1 for $V_{OUT1} < 5V$ and $V_{IN} > 5V$.

The latter connection will provide higher efficiency. If this bias supply is stuffed, please keep the following points in mind:

- 1) If the input voltage of the optional bias supply is connected to VIN, then the board will need to be slightly modified to ensure that the voltage on the EXTVCC pin of the LTC3728EG does not exceed the voltage on the VIN pin. These are the modifications:
 - a) Remove resistor R8.
 - b) Tie the (+) end of C3 to the (+) end of C21.
- 2) If the input voltage of the optional bias supply is connected to output #1, precautions need

to be taken to make sure that the voltage on the EXTVCC pin of the LTC3728EG does not exceed the voltage on the VIN pin during turn-on of the main converter. Follow the steps below:

- a) Put jumper JP6 in the “0” position to tie the RUN1 signal to ground.
 - b) Turn-on the main input voltage and set to desired level.
 - c) Put jumper JP6 in the “1” position to turn-on output #1.
- 3) If a different power MOSFET configuration is used or the switching frequency is increased, then be sure to measure the current flowing into the EXTVCC pin and make sure the current will not exceed the maximum output current of the bias supply. At 3.3V input, the maximum output current of the bias supply is 200mA.

For further assistance, contact the factory.

QUICK START GUIDE FOR DEMONSTRATION CIRCUIT 542

DUAL PHASE, DUAL OUTPUT SYNCHRONOUS BUCK CONVERTER

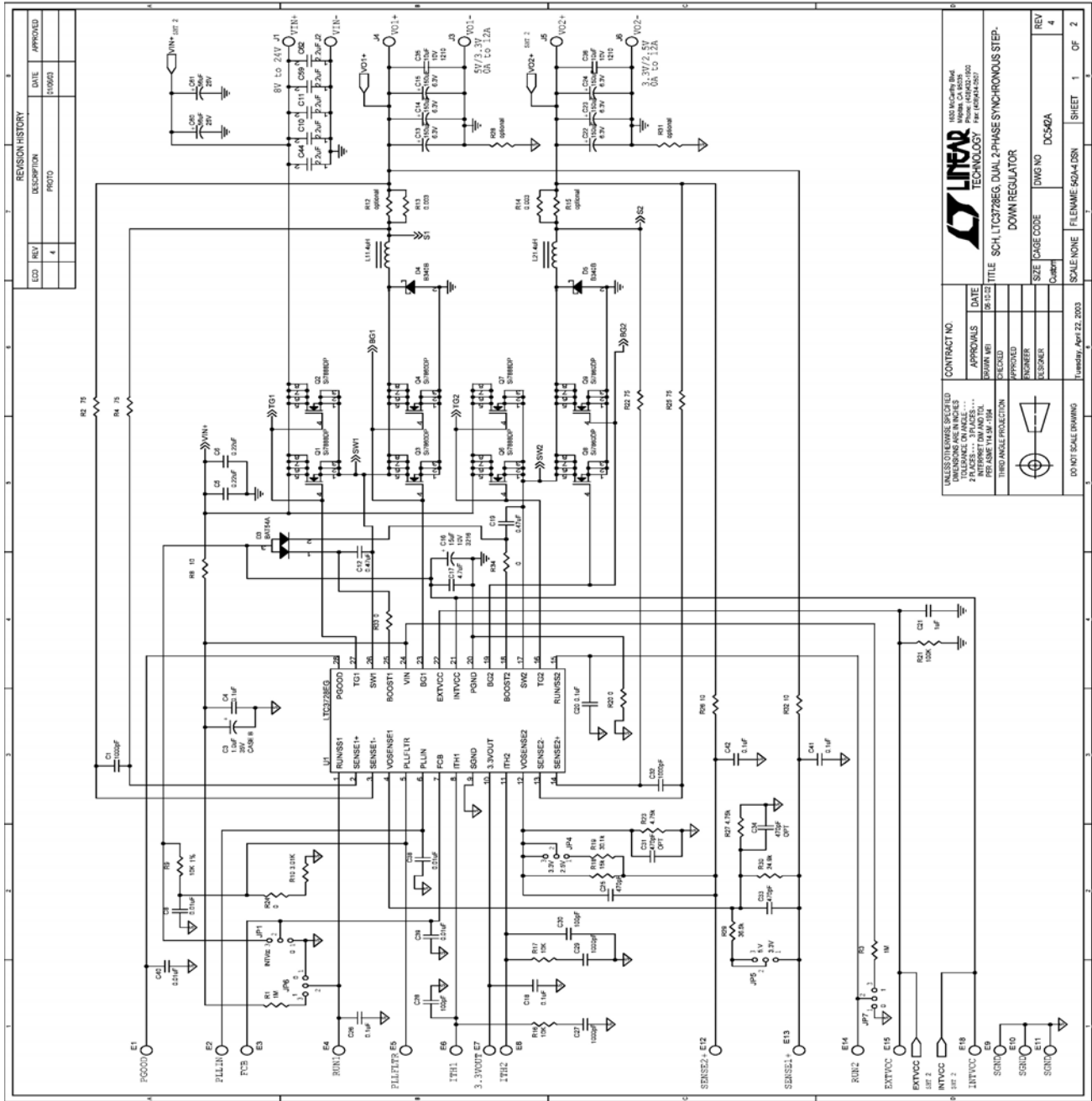

REVISION HISTORY		
ECO	REV	DATE
	4	11/06/2
		APPROVED

		CONTRACT NO. 103-MC076-BM APPROVALS: [Signature] DATE: 06/12/22 APPROVED: [Signature] CHECKED: [Signature] DRAWN BY: [Signature] TITLE: SCH. LTC3786C, DUAL 2-PHASE SYNCHRONOUS STEP-DOWN REGULATOR SIZE: PAGE CODE: DWS NO. DCS-60A SHEET 1 OF 2
UNLESS OTHERWISE SPECIFIED TOLERANCE ON ANGLES: 0.1° MINIMUM 0.5° TYPICAL 1.0° MAXIMUM PER ANSI Y14.5M-1994 THIRD ANGLE PROJECTION DO NOT SCALE DRAWING		DRAWN: [Signature] DATE: 06/12/22 CHECKED: [Signature] APPROVED: [Signature] TITLE: SCH. LTC3786C, DUAL 2-PHASE SYNCHRONOUS STEP-DOWN REGULATOR SIZE: PAGE CODE: DWS NO. DCS-60A SHEET 1 OF 2

QUICK START GUIDE FOR DEMONSTRATION CIRCUIT 542

DUAL PHASE, DUAL OUTPUT SYNCHRONOUS BUCK CONVERTER

REVISION HISTORY				
ECO	REV	DESCRIPTION	DATE	APPROVED
	4	PROTO	01/06/03	

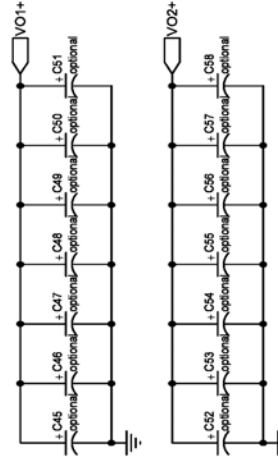
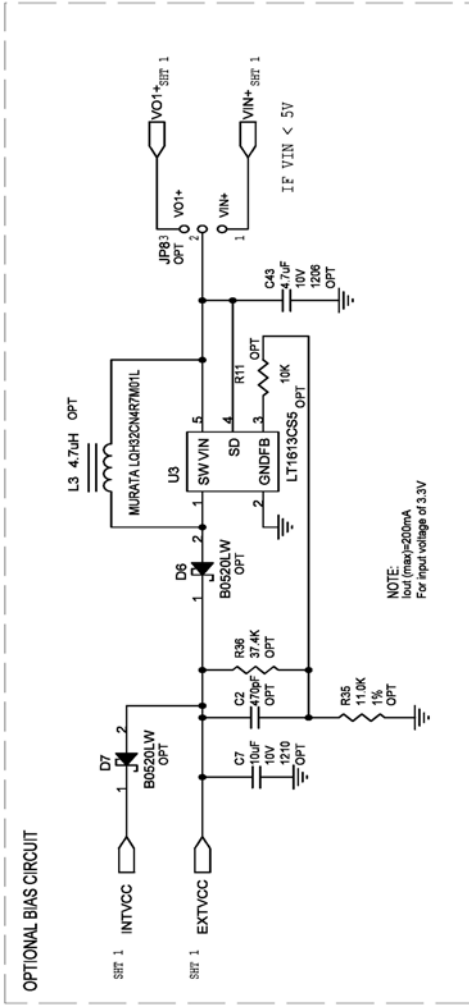

UNLESS OTHERWISE SPECIFIED DIMENSIONS ARE IN INCHES TOLERANCE ON ANGLE ... 2 PLACES ... 3 PLACES ... INTERPRET DIM AND TOL PER ASME Y14.5M-1994	CONTRACT NO.	DATE		DO NOT SCALE DRAWING
	APPROVALS	06-07-02		
	DRAWN: MEI	CHECKED:		
	APPROVED:	ENGINEER:		
	DESIGNER:			
	Tuesday, April 22, 2003			
	SCALE: NONE	FILENAME: 542A-4.DSN	SHEET 2	OF 2

	1630 McCarthy Blvd. Milpitas, CA 95035 Phone: (408)432-1600 Fax: (408)434-0507	
	LINEAR TECHNOLOGY	
SCH, LTC3728EG, DUAL 2-PHASE SYNCHRONOUS STEP-DOWN REGULATOR		
SIZE	CAGE CODE	DWG NO
A		DC542A
REV		4



Компания «ЭлектроПласт» предлагает заключение долгосрочных отношений при поставках импортных электронных компонентов на взаимовыгодных условиях!

Наши преимущества:

- Оперативные поставки широкого спектра электронных компонентов отечественного и импортного производства напрямую от производителей и с крупнейших мировых складов;
- Поставка более 17-ти миллионов наименований электронных компонентов;
- Поставка сложных, дефицитных, либо снятых с производства позиций;
- Оперативные сроки поставки под заказ (от 5 рабочих дней);
- Экспресс доставка в любую точку России;
- Техническая поддержка проекта, помощь в подборе аналогов, поставка прототипов;
- Система менеджмента качества сертифицирована по Международному стандарту ISO 9001;
- Лицензия ФСБ на осуществление работ с использованием сведений, составляющих государственную тайну;
- Поставка специализированных компонентов (Xilinx, Altera, Analog Devices, Intersil, Interpoint, Microsemi, Aeroflex, Peregrine, Syfer, Eurofarad, Texas Instrument, Miteq, Cobham, E2V, MA-COM, Hittite, Mini-Circuits, General Dynamics и др.);

Помимо этого, одним из направлений компании «ЭлектроПласт» является направление «Источники питания». Мы предлагаем Вам помощь Конструкторского отдела:

- Подбор оптимального решения, техническое обоснование при выборе компонента;
- Подбор аналогов;
- Консультации по применению компонента;
- Поставка образцов и прототипов;
- Техническая поддержка проекта;
- Защита от снятия компонента с производства.



Как с нами связаться

Телефон: 8 (812) 309 58 32 (многоканальный)

Факс: 8 (812) 320-02-42

Электронная почта: org@eplast1.ru

Адрес: 198099, г. Санкт-Петербург, ул. Калинина, дом 2, корпус 4, литера А.